

The Arc.



Spec Sheet

Five
At
Heart

High density storage that protects your bike and your back.



**Five
At
Heart**

The logo for Five At Heart features the text "Five At Heart" in a bold, black, sans-serif font. To the right of the text is a stylized heart shape composed of a black circle with five red lines radiating from its center, resembling a compass rose or a star.

Staggered.



The Arc

Five At Heart

Material

Mild steel base with powder coated black hammertone finish

Mill finish aluminium carriage

Lock Bars, handle and lower wheel catcher standard powder coat colour yellow (custom colours available, minimum order 20)

Specification

(X) Aisle

AUS Standard (2890.3) 2000mm (6'7")

Manufacturer 1800mm (5'11")

Minimum Requirement

(Y) Centre Spacing

AUS Standard (2890.3) 400mm (1' 3 3/4")

Manufacturer 400mm (1' 3 3/4")

Minimum Requirement

San Francisco (CA) Standard 430mm (1'5")

(Z) Ceiling Height Minimum

AUS Standard (2890.3) 2700mm (8'10")

Manufacturer 2600mm (8'6")

Minimum Requirement

TOP VIEW

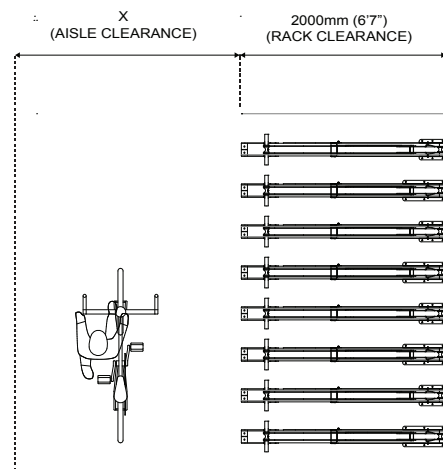

SIDE VIEW

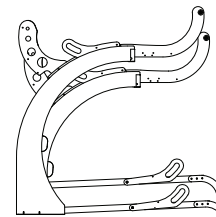

FRONT VIEW

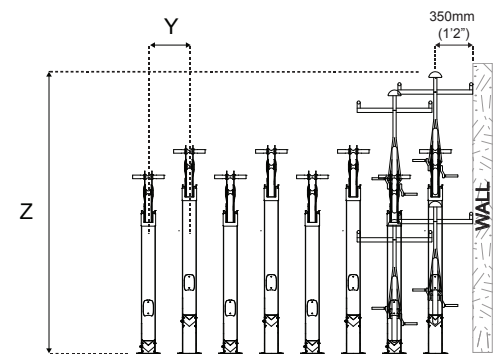

Double Sided.

The Arc



Five At Heart

Material

Mild steel base with powder coated black hammertone finish

Mill finish aluminium carriage

Lock Bars, handle and lower wheel catcher standard powder coat colour yellow (custom colours available, minimum order 20)

Specification

(X) Aisle

AUS Standard (2890.3) 2000mm (6'7")

Manufacturer Minimum Requirement 1800mm (5'11")

(Y) Centre Spacing

AUS Standard (2890.3) 400mm (1' 3 3/4")

Manufacturer Minimum Requirement 400mm (1' 3 3/4")

San Francisco (CA) Standard 430mm (1'5")

(Z) Ceiling Height Minimum

AUS Standard (2890.3) 2700mm (8'10")

Manufacturer Minimum Requirement 2600mm (8'6")

TOP VIEW

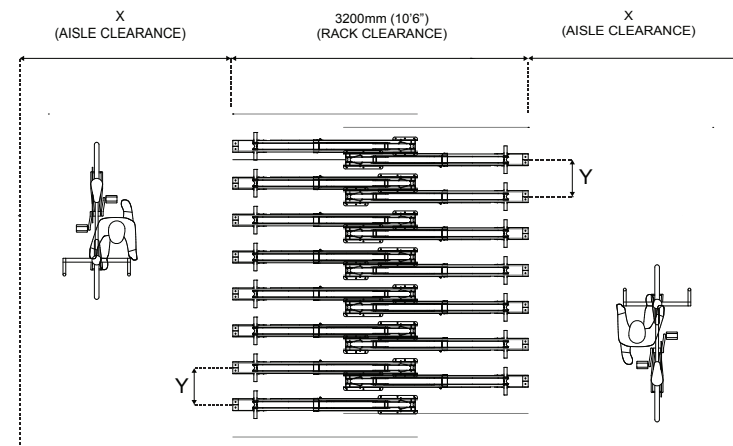

SIDE VIEW

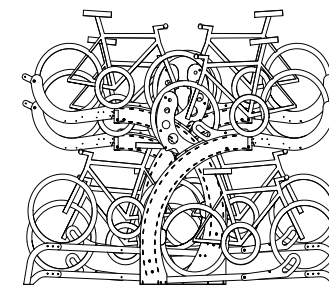

FRONT VIEW

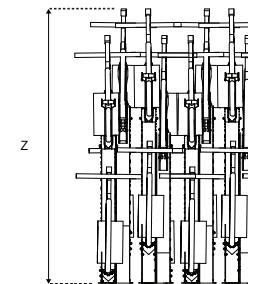

Single Level.

The Arc



Five At Heart

Material

Mild steel base with powder coated black hammertone finish

Mill finish aluminium carriage

Lock Bars, handle and lower wheel catcher standard powder coat colour yellow (custom colours available, minimum order 20)

Specification

(X) Aisle

AUS Standard (2890.3) 2000mm (6'7")

Manufacturer 1800mm (5'11")
Minimum Requirement

(Z) Ceiling Height Minimum

Manufacturer 2400 (7'11")
Minimum Requirement

(Y) Centre Spacing

AUS Standard (2890.3) 700mm (2'4")

Manufacturer 600mm (2')
Minimum Requirement

TOP VIEW

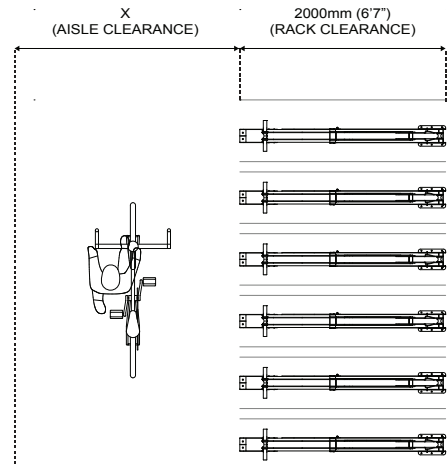

SIDE VIEW

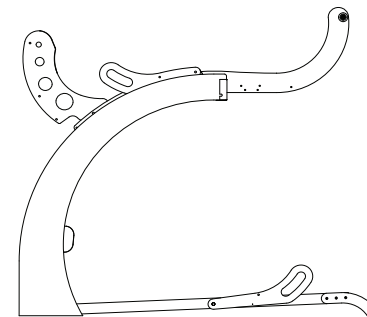

FRONT VIEW

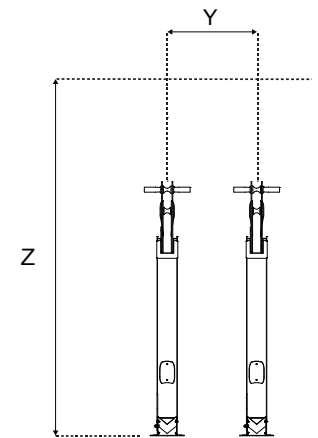

Arc Warranty and Technical Data

Warranty Information

Five At Heart products come with a standard 2 year warranty, effective from the handover date.

For the warranty period, we warrant that the equipment (and any materials) we supply will comply with the relevant standards at the date of installation.

This warranty is limited and may be excluded in part or in full in light of user damage or failure to install to Five At Heart specification.

We recommend a monthly visual inspection for signs of damage or need for cleaning.

Contact Five At Heart in the event of product damage.

Fixing options /and detail

Fig 1 M10/50mm (1 15/16") galvanised sleeve anchor

Product Weight

Low – 46kg
High – 53kg

Substrate Requirements

- Concrete – 100mm (3 15/16") thick and in good condition

Maintenance Requirements

Slide unit bearings are sealed and do not require on going maintenance.

If any moving parts appear to be malfunctioning, discontinue use and contact Five At Heart.

Cleaning

Cleaning should start at the time the products are installed, ensuring that construction materials such as concrete, plaster and paint splashes are removed before they have a chance to dry. Failure to remove these materials will require aggressive cleaning in the future, that may be harmful to the products.

Wipe with a damp cloth for surface cleaning. Regular cleaning may be done with a solution of warm water and a non-abrasive, pH neutral detergent solution. Surfaces should be thoroughly rinsed after cleaning to remove all residues.

WARNING: DO NOT UNDER ANY CIRCUMSTANCES USE STRONG SOLVENTS SUCH AS THINNERS OR SOLUTIONS CONTAINING CHLORINATED HYDROCARBONS, ESTERS OR KETONES. ABRASIVE CLEANERS OR CUTTING COMPOUNDS SHOULD NOT BE USED.

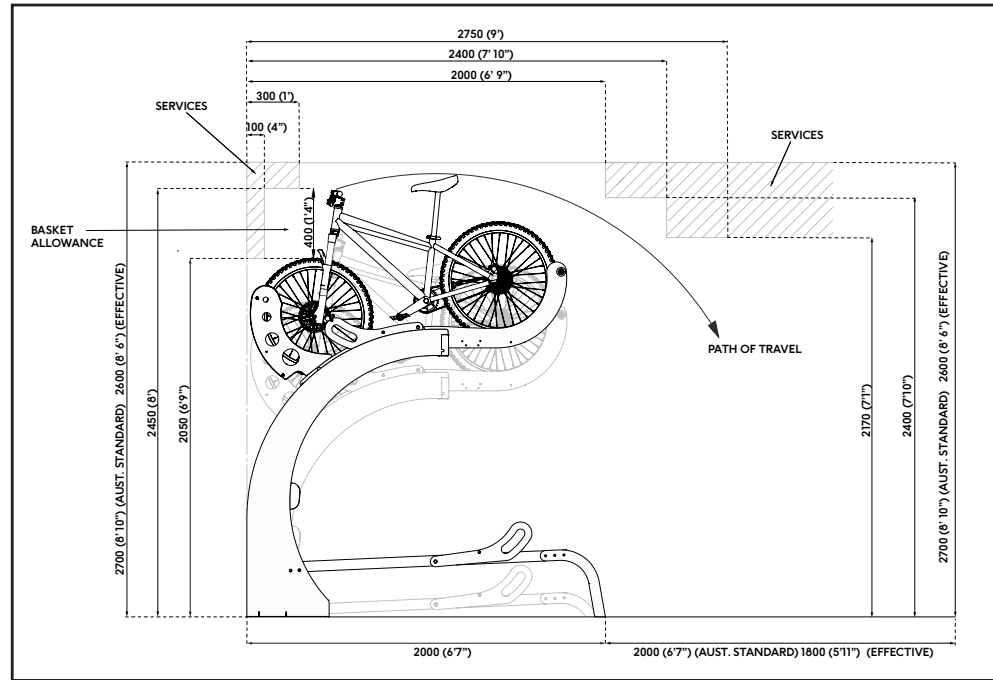

Arc clearance map – Staggered unit

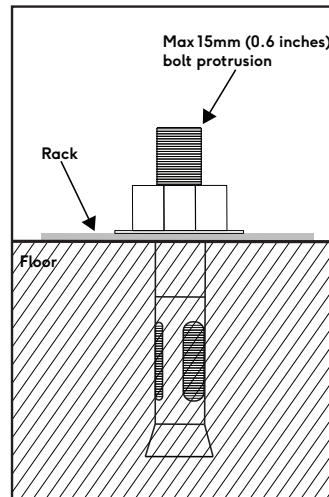

Fig 1 M10/50mm (3/8" x 3") galvanised sleeve anchor

Five At Heart



Creating
spaces
for however
you Roll...



fiveatheart.com

Australia

1300 769 332 or au_info@fiveatheart.com

North America

1888 218 3433 or na_info@fiveatheart.com

Europe

(+44) 20313 71966 or eu_info@fiveatheart.com