

TYPICAL AHU ROOF TURRET  
DETAIL  
N.T.S

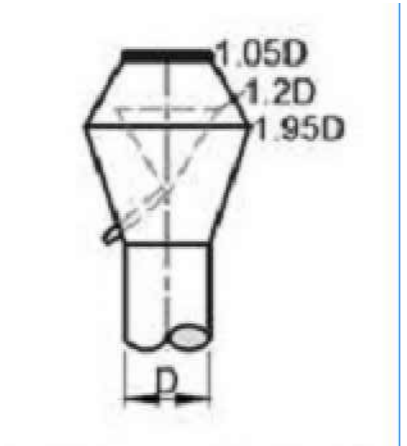
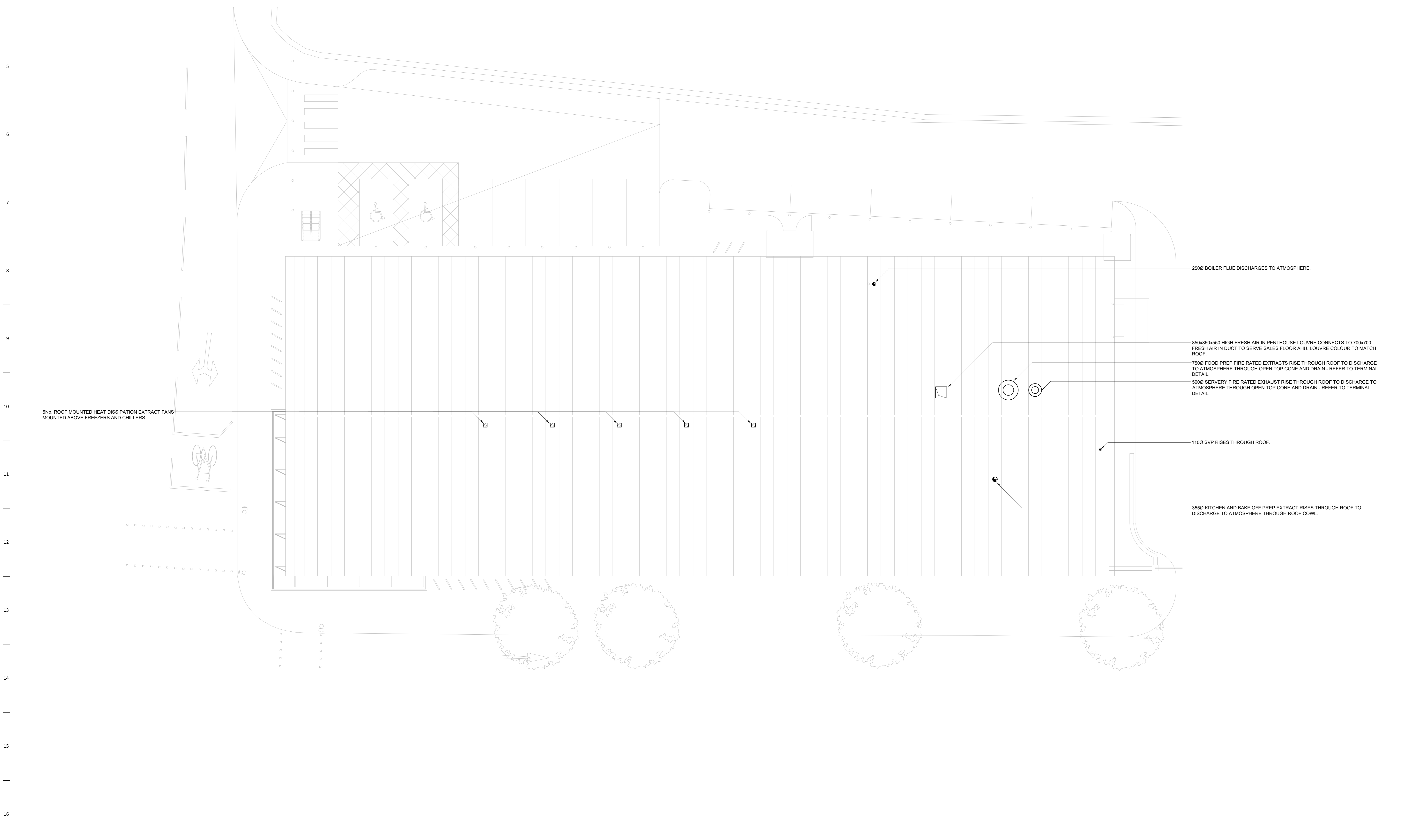

FIG 12e - OPEN TOP  
CONE AND DRAIN  
KITCHEN EXHAUST TERMINAL -  
TYPICAL



- GENERAL NOTES**
1. THIS DRAWING SHALL BE READ IN CONJUNCTION WITH ALL ASSOCIATED SERVICES DRAWINGS, ARCHITECTS AND STRUCTURAL DRAWINGS TOGETHER WITH THE SCHEMATIC DRAWINGS AND ALL MECHANICAL, ELECTRICAL AND OTHER RELEVANT SPECIFICATIONS.
  2. ALL SERVICES INSTALLATIONS SHALL BE CO-ORDINATED AND FULLY INTEGRATED WITH THE MECHANICAL AND ELECTRICAL SERVICES, ARCHITECTURAL FEATURES, SPECIALIST PLANT AND STRUCTURAL ELEMENTS.
  3. THE SERVICES CONTRACTORS SHALL FAMILIARISE THEMSELVES WITH THE MECHANICAL AND ELECTRICAL SERVICES, ARCHITECTURAL FEATURES, SPECIALIST PLANT AND STRUCTURAL ELEMENTS.
  4. THE INSTALLING SUB-CONTRACTOR SHALL ISSUE FULL 'WORKING DRAWINGS' IN LINE WITH THE SPECIFICATION PROVIDED. THE 'WORKING DRAWINGS' SHALL BE ISSUED TO ALL DESIGN TEAM MEMBERS FOR THEIR COMMENT PRIOR TO INSTALLATION. THE INSTALLATION AND CO-ORDINATION OF SERVICES WITH OTHER SERVICES, THIRD PARTY SUPPLIERS AND THE BUILDING FABRIC IS THE RESPONSIBILITY OF THE INSTALLING SUB-CONTRACTOR.

This drawing is the property of DDA Ltd Consultant Engineers. It must not be reproduced in whole or in part, nor the design used without prior written consent. This drawing and associated documents are strictly private and confidential and should not be disclosed with anyone other than members of the design team. Do not scale from this drawing.

**SAFETY, HEALTH & ENVIRONMENTAL INFORMATION**

Refer to the DDA Ltd project specific risk assessment and design criteria for the M&E services installation. The installing contractor must provide method statements for the installation works and agree all works in advance with the main contractor.

It is assumed that all works associated with this drawing will be carried out by competent operatives working, where appropriate, to an approved method.

**NOTES**

**FOR PLANNING**

Rev	Date	Description	Eng.
B	10/2/21	ROOF PENETRATIONS AND DISCHARGE TERMINALS REVISED	AP
A	01/2/21	MECHANICAL EQUIPMENT REMOVED FROM DRAWING	AP



Project:  
**MORRISONS  
CAMDEN TEMPORARY STORE**

Drawing Title:  
**ROOF  
MECHANICAL SERVICES  
LAYOUT**

Scale at A0: 1:100	Date: 26-03-20
Drawn: A. PARRY	Engineer: A. PARRY
Status: PLANNING	Checked: P. GUEST
Drawing No: 19/3359/M50/RF01	Rev: B