



TECHNICAL SPECIFICATION

Model:	Electrostatix PCL 5000 SP 'in-duct' electrostatic precipitator complete and ready for operation	
Quantity:	One	
Purpose:	Plasma Clean's electrostatic precipitator is designed for the high efficiency removal of grease and smoke particles in commercial kitchen exhaust applications. It should be placed as close to the kitchen canopy as possible to reduce grease build up in the downstream ductwork.	
	Direction of air flow (right to left; left to right) is to be specified on ordering	
Construction:	Purpose built unit with access door on one side for the withdrawal of the filter components	
Features & Benefits:	<ul style="list-style-type: none"> • Stainless steel spiked ioniser blades offer significantly longer life than wire ionisers • Low pressure drop - 90Pa (dirty) • Extra depth collector cells provide greater collection efficiency • 95% single pass efficiency • Solid state power supply for longer life • Two year parts only warranty, subject to maintenance 	
Dimensions:	533H x 1085W x 635D mm	
Filtration:	Each unit incorporates a 3 stage filtration system consisting of:	
	1)	Aluminium pre filter
	2)	Combined electronic Ioniser / Electrostatic collector cells
	3)	Aluminium post filter
Control lights:	On/Off switch with indicator lamp	
Technical Data:	Capacity max	1.4 m ³ /s
	Supply	230Vac/ 1 phase / 50Hz
	Power	50W
	Weight	80kg
	Pressure drop	90Pa (dirty filters)
Power supply:	High frequency solid state design	
General:	Multiple units can be joined together for increased volume or efficiency	
Finish:	Blue Epoxy Powder Coat	
Accessories:	Nil	
Delivery:	Stock item	
Approvals:	Plasma Clean air cleaners comply with current CE requirements and EMC standards. Certificates are available on request.	
Warranty:	One year manufacturer's warranty for parts and labour plus an additional 12 month warranty on parts only. Terms and conditions apply. Optional maintenance packages available, sold separately.	
Terms:	In accordance with our standard terms of business.	

Maintenance

A Plasma Clean service contract is available (please enquire) and in any case Plasma Clean would recommend:

- Servicing is normally confined to the regular cleaning of the filter components (steam or degreasing fluid).
- The aluminium prefilters require washing when dirty
- Cleaning of the ionisers and collector cells should be carried out on a regular basis
- For maximum efficiency establish a regular cleaning cycle based on routine checks of the ionisers and collector cells during the first few months of use.

Technical Drawing: Electrostatic PCL 5000 SP

Please contact our Technical Helpdesk if a CAD drawing is required.

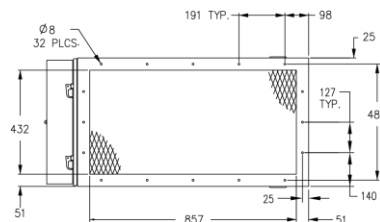
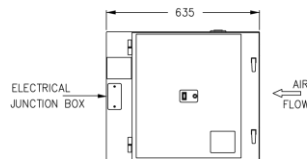
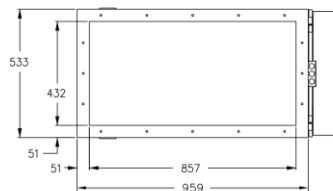
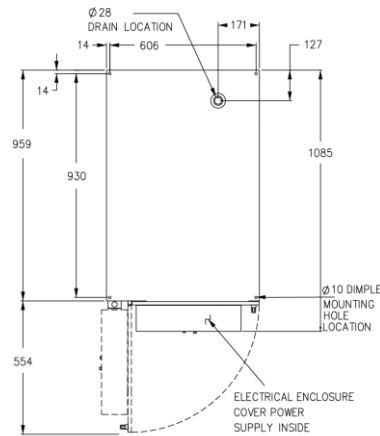

PLASMA CLEAN LIMITED, SBIC, Broadstone Mill, Broadstone Road, Stockport, Cheshire SK5 7DL UK
 T +44 (0)161 870 2325 | F +44 (0)161 332 7813 | E ask@plasma-clean.com | W www.plasma-clean.com