

OMMX
 E25, Cockpit Arts
 Northington Street
 London WC1N 2NP

+44 (0)20 7405 5484
 www.officemmx.com

Project 17 Falkland Road
 No. O110

Client Charles Emmerson

Drawing Title Existing 1st Floor Front Windows
 Drawing No. 2.50

Revision	Date	Description
-	-----	For Planning
A	20.09.20	Glazing bar details added

Notes

Key Plan



Drawn JL
 Checked -
 Scale 1:20 @ A3

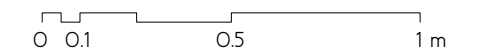

This drawing is to be read in conjunction with all other contract documents and specifications and all other consultants drawings. All levels and dimensions should be checked on site and any discrepancies notified to OMMX prior to proceeding with works. No drawing should be reproduced in any form without prior written permission from OMMX.

© OMMX

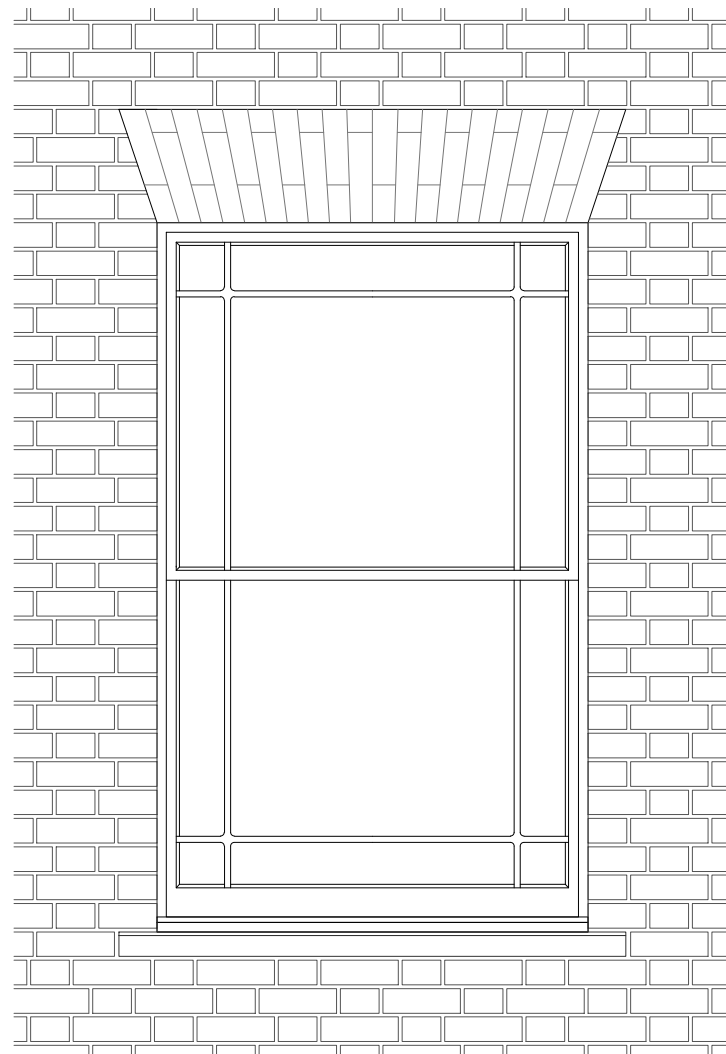

Elevation

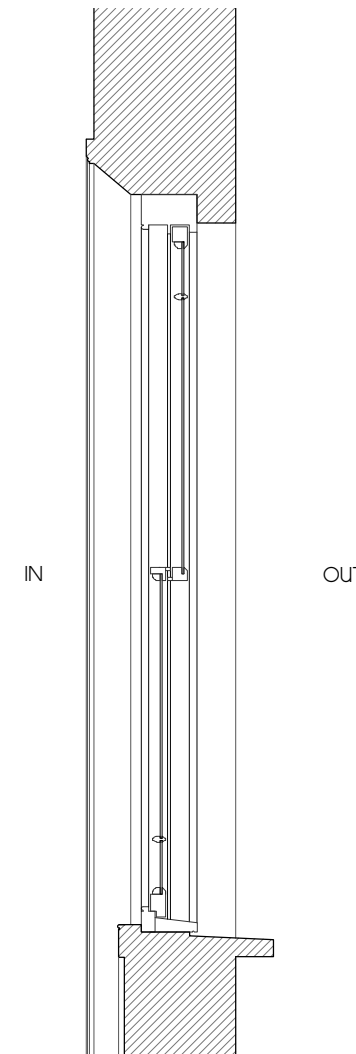

Section AA

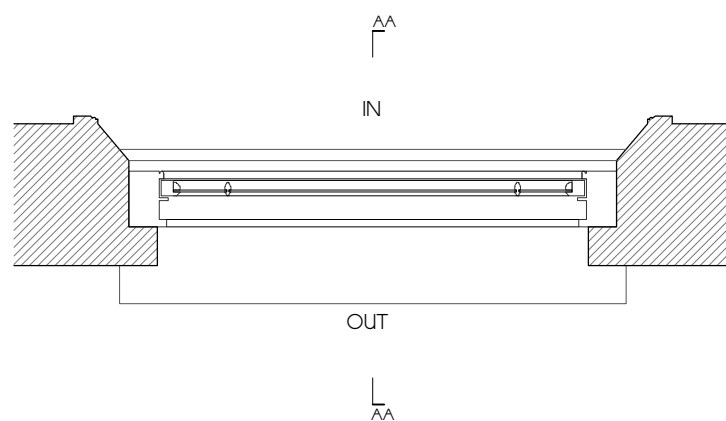

Plan

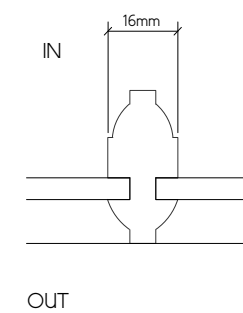

Section through glazing bar, scale 1:1

OMMX
 E25, Cockpit Arts
 Northington Street
 London WC1N 2NP

+44 (0)20 7405 5484
 www.officemmx.com

Project No. 17 Falkland Road
 0110

Client Charles Emmerson

Drawing Title Existing 2nd Floor Front Windows
 Drawing No. 2.51

Revision	Date	Description
-	----	For Planning
A	20.09.20	Glazing bar details added

Notes

Key Plan



Drawn JL
 Checked -
 Scale 1:20 @ A3

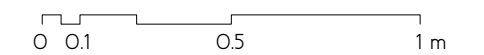

This drawing is to be read in conjunction with all other contract documents and specifications and all other consultants drawings. All levels and dimensions should be checked on site and any discrepancies notified to OMMX prior to proceeding with works. No drawing should be reproduced in any form without prior written permission from OMMX.

© OMMX

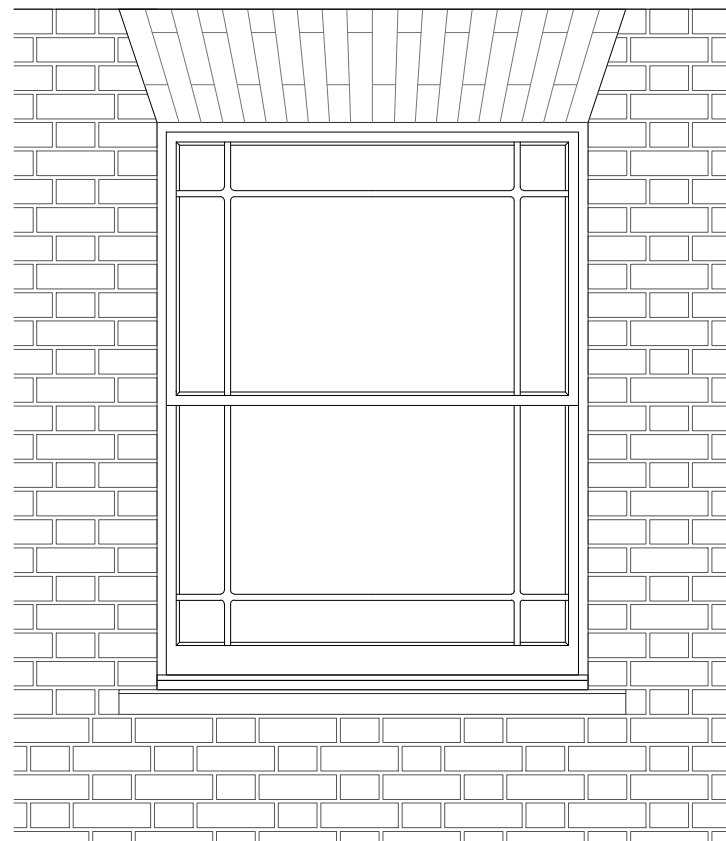

Elevation

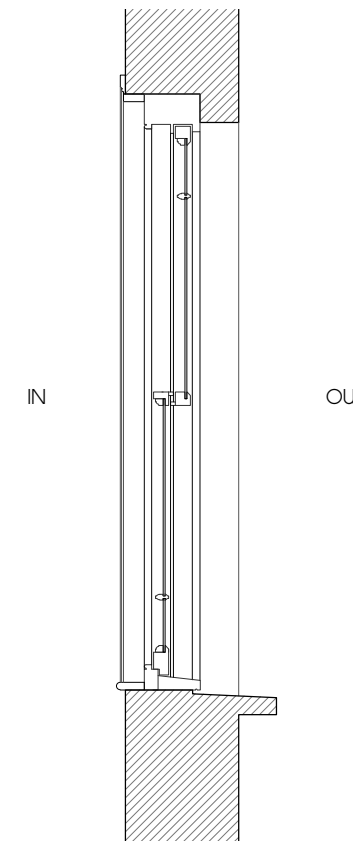

Section AA

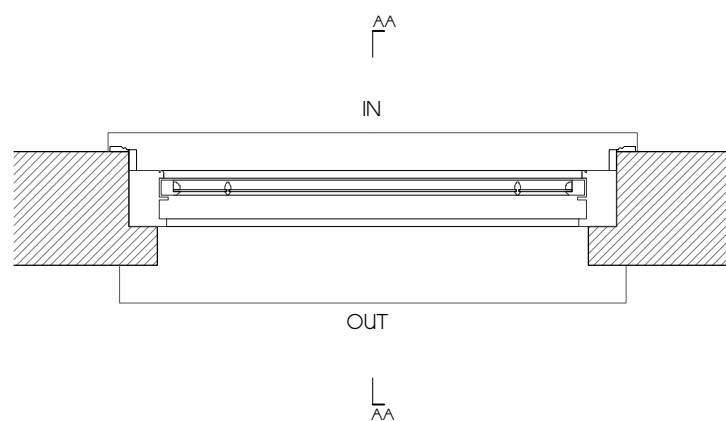

Plan

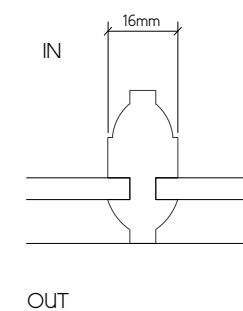

Section through glazing bar, scale 1:1

OMMX
 E25, Cockpit Arts
 Northington Street
 London WC1N 2NP

+44 (0)20 7405 5484
 www.officemmx.com

Project No. 17 Falkland Road
 0110

Client Charles Emmerson

Drawing Title Existing 1st Floor
 Rear Window
 Drawing No. 2.52

Revision	Date	Description
-	-----	For Planning
A	20.09.20	Glazing bar details added

Notes

Key Plan



Drawn JL
 Checked -
 Scale 1:20 @ A3

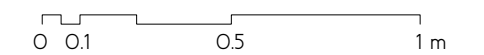

This drawing is to be read in conjunction with all other contract documents and specifications and all other consultants drawings. All levels and dimensions should be checked on site and any discrepancies notified to OMMX prior to proceeding with works. No drawing should be reproduced in any form without prior written permission from OMMX.

© OMMX

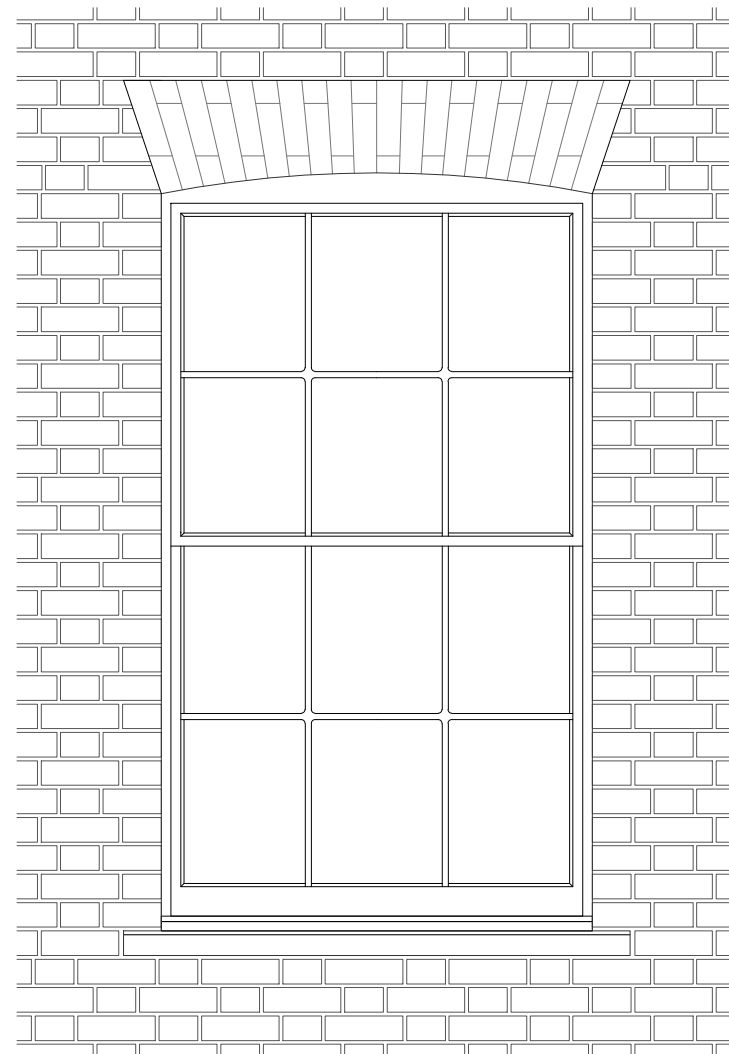

Elevation

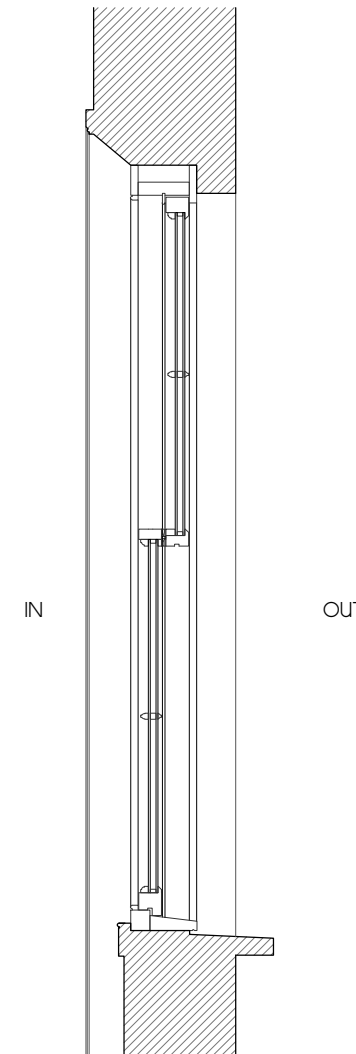

Section AA

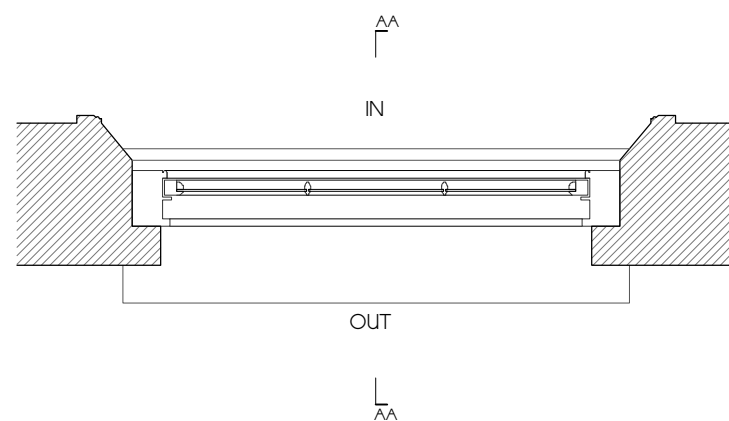

Plan

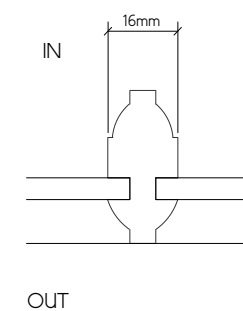

Section through glazing bar, scale 1:1

OMMX
 E25, Cockpit Arts
 Northington Street
 London WC1N 2NP

+44 (0)20 7405 5484
 www.officemmx.com

Project No. 17 Falkland Road
 0110

Client Charles Emmerson

Drawing Title Existing 2nd Floor
 Rear Window
 Drawing No. 2.53

Revision	Date	Description
-	-----	For Planning
A	20.09.20	Glazing bar details added

Notes

Key Plan

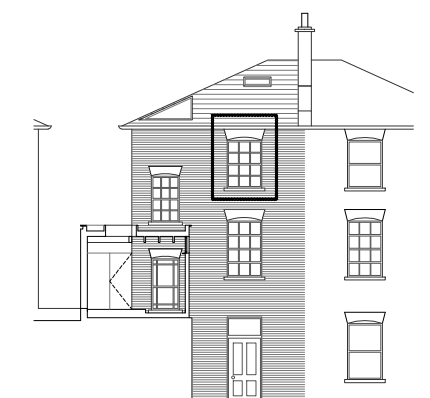

Drawn JL
 Checked -
 Scale 1:20 @ A3

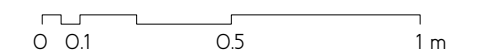

This drawing is to be read in conjunction with all other contract documents and specifications and all other consultants drawings. All levels and dimensions should be checked on site and any discrepancies notified to OMMX prior to proceeding with works. No drawing should be reproduced in any form without prior written permission from OMMX.

© OMMX

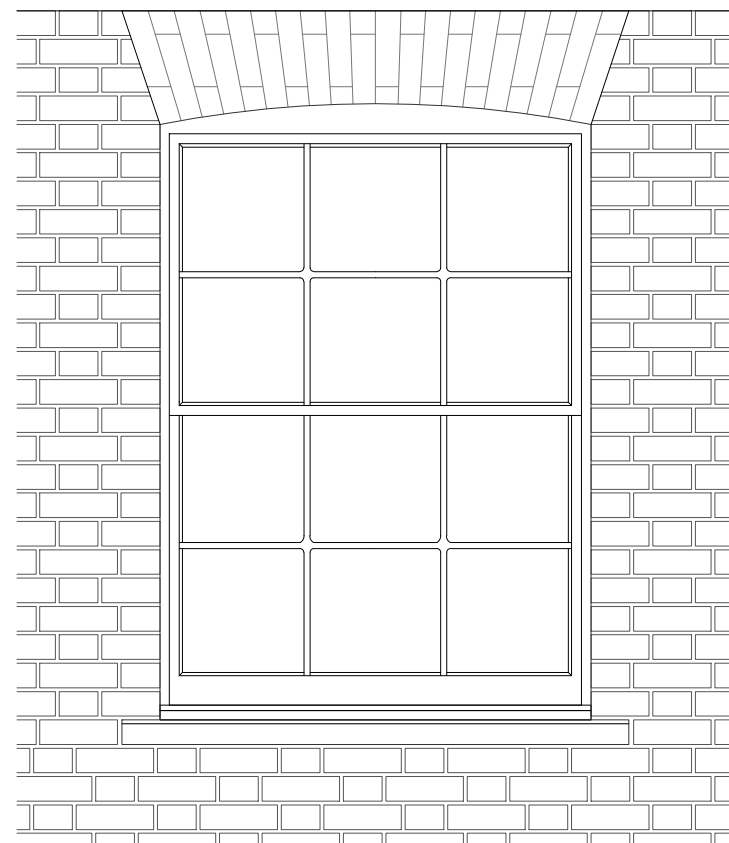

Elevation

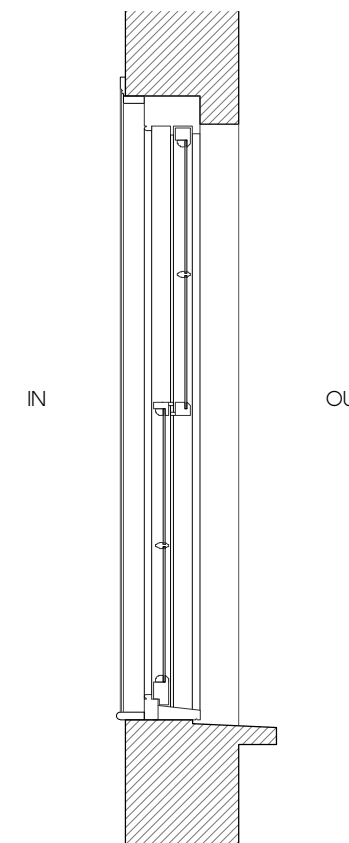

Section AA

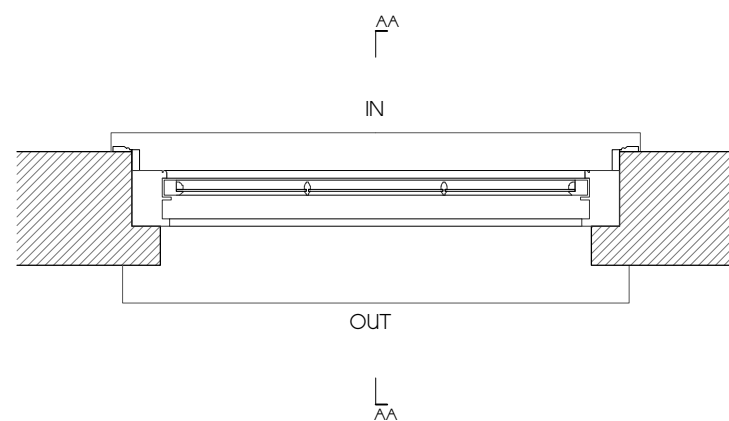

Plan

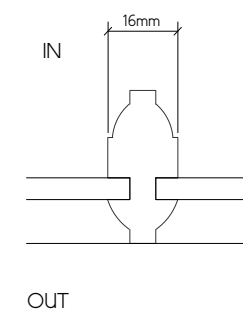

Section through glazing bar, scale 1:1

Revision	Date	Description
-	----	For Planning
A	20.09.20	Glazing bar details added

Notes

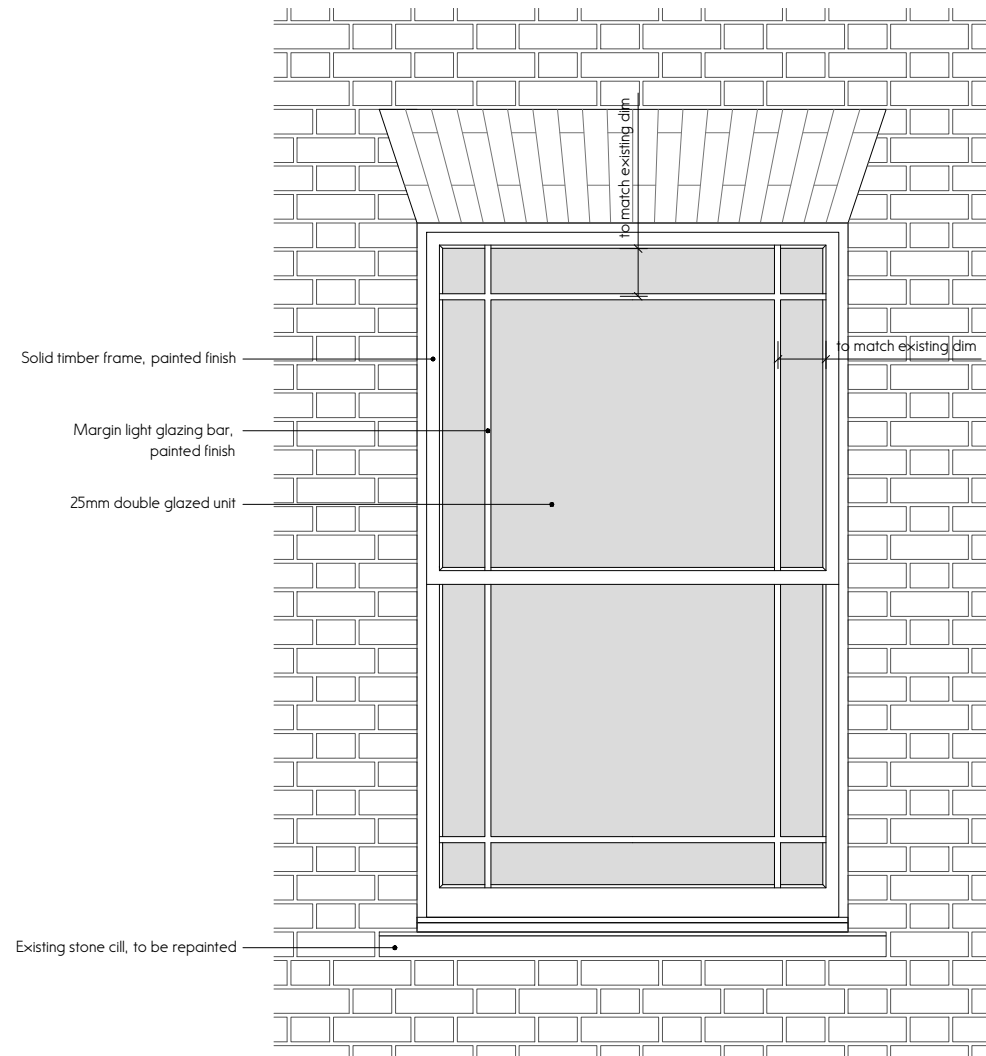

Elevation

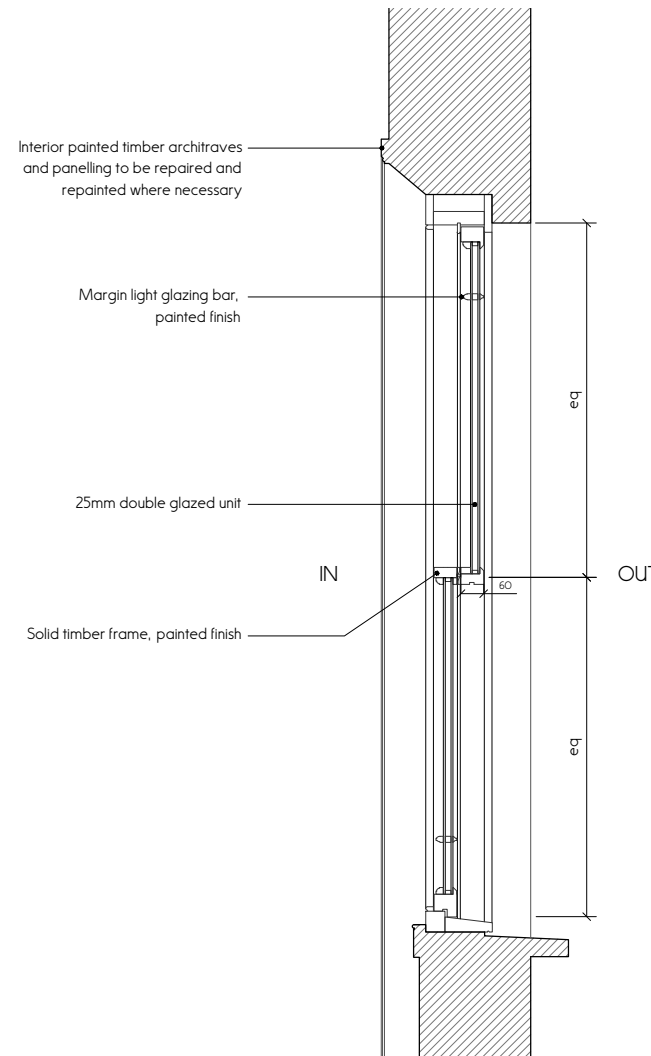

Section AA

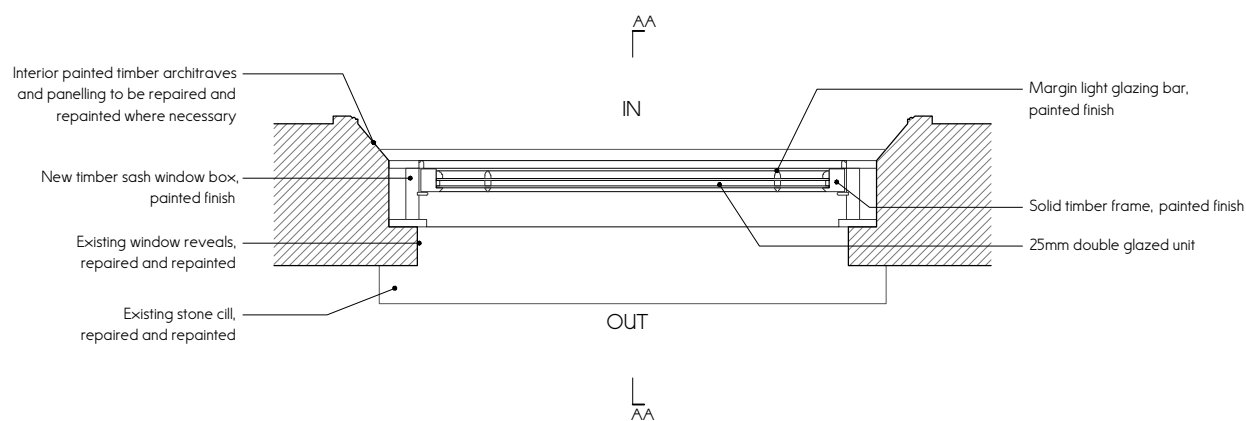

Plan

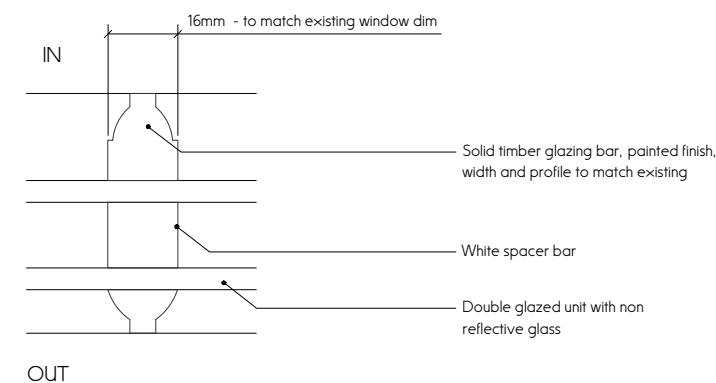

Section through glazing bar, scale 1:1

Key Plan



Drawn JL
 Checked -
 Scale 1:20 @ A3

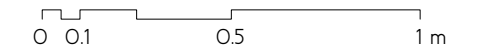

This drawing is to be read in conjunction with all other contract documents and specifications and all other consultants drawings. All levels and dimensions should be checked on site and any discrepancies notified to OMMX prior to proceeding with works. No drawing should be reproduced in any form without prior written permission from OMMX.

OMMX
 E2S, Cockpit Arts
 Northington Street
 London WC1N 2NP

+44 (0)20 7405 5484
 www.officemmx.com

Project 17 Falkland Road
 No. O110

Client Charles Emmerson

Drawing Title Proposed 2nd Floor Front Windows
 Drawing No. 2.61

Revision	Date	Description
-	-----	For Planning
A	20.09.20	Glazing bar details added

Notes

Key Plan



Drawn JL
 Checked -
 Scale 1:20 @ A3

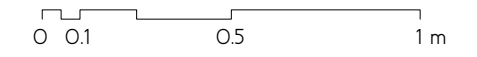

This drawing is to be read in conjunction with all other contract documents and specifications and all other consultants drawings. All levels and dimensions should be checked on site and any discrepancies notified to OMMX prior to proceeding with works. No drawing should be reproduced in any form without prior written permission from OMMX.

© OMMX

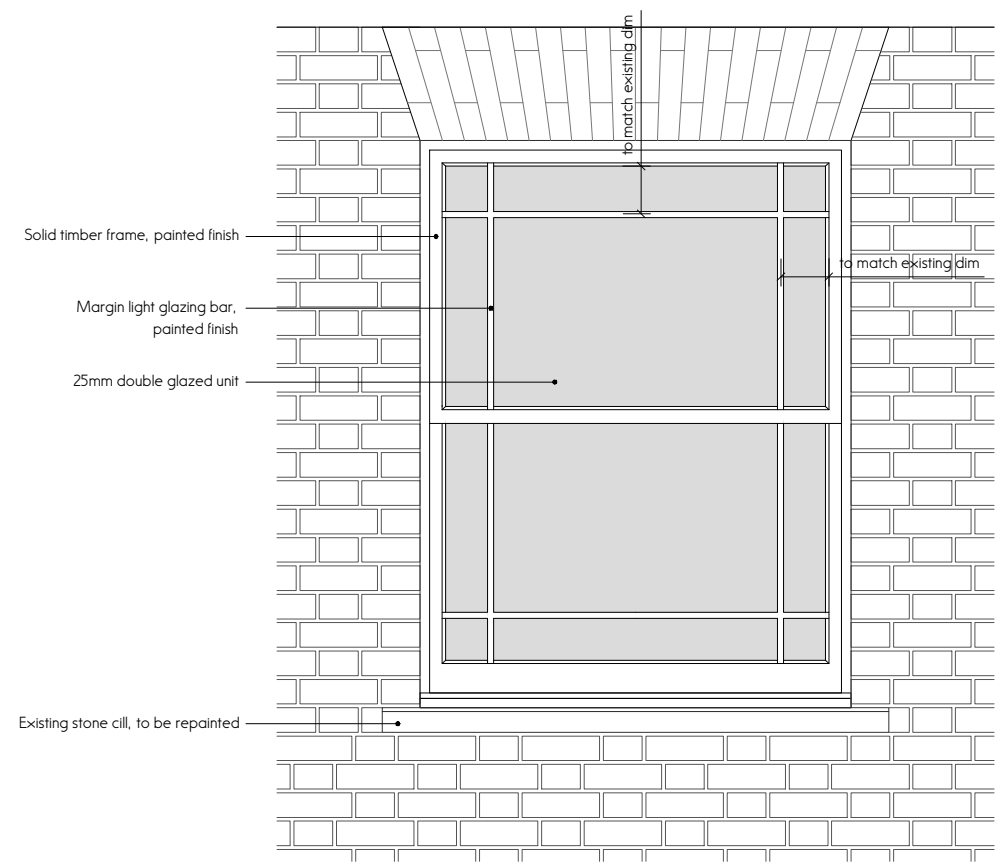

Elevation

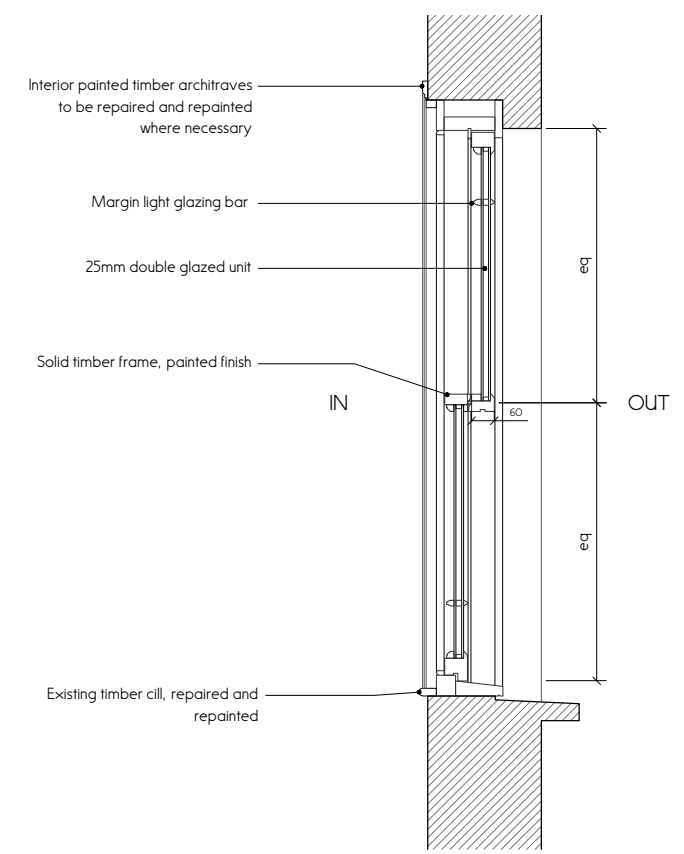

Section AA

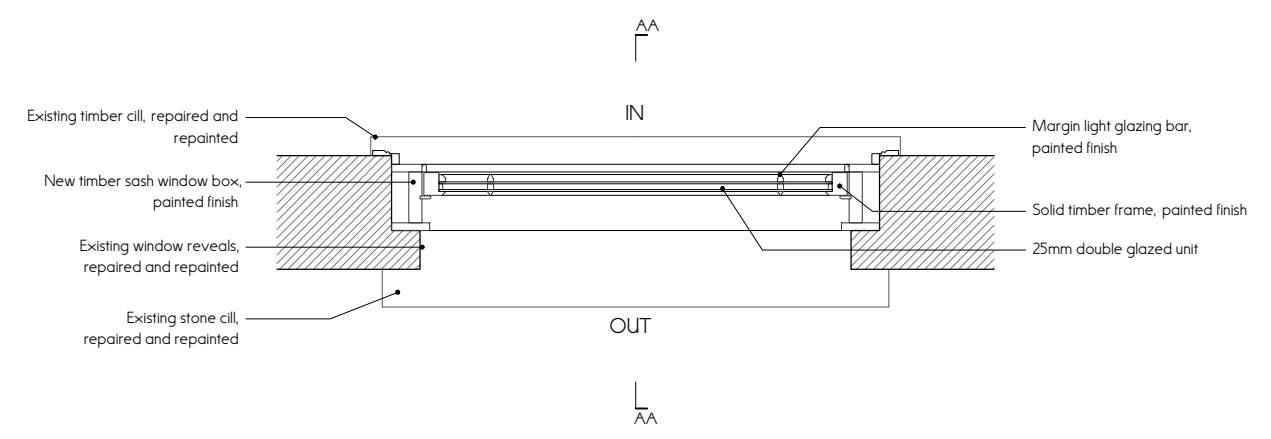

Plan

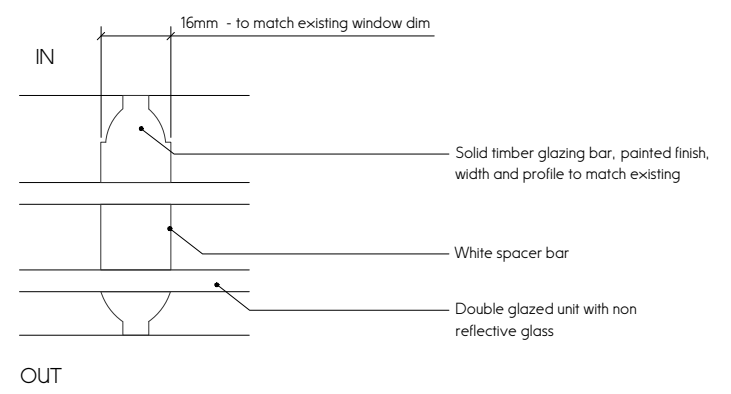

Section through glazing bar, scale 1:1

OMMX
 E25, Cockpit Arts
 Northington Street
 London WC1N 2NP

+44 (0)20 7405 5484
 www.officemmx.com

Project No. 17 Falkland Road
 0110

Client Charles Emmerson

Drawing Title Proposed 1st Floor
 Rear Window
 Drawing No. 2.62

Revision	Date	Description
-	-----	For Planning
A	20.09.20	Glazing bar details added

Notes
 -

Key Plan

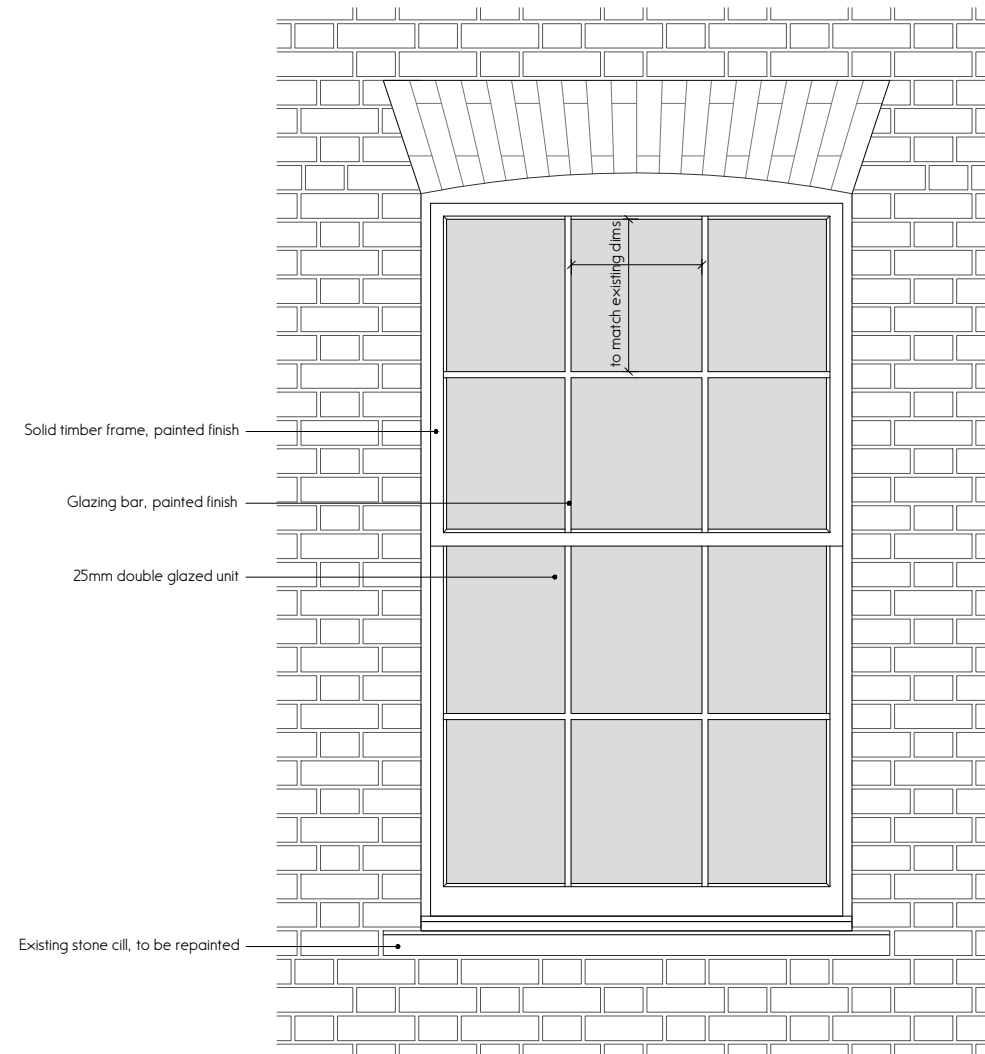

Elevation

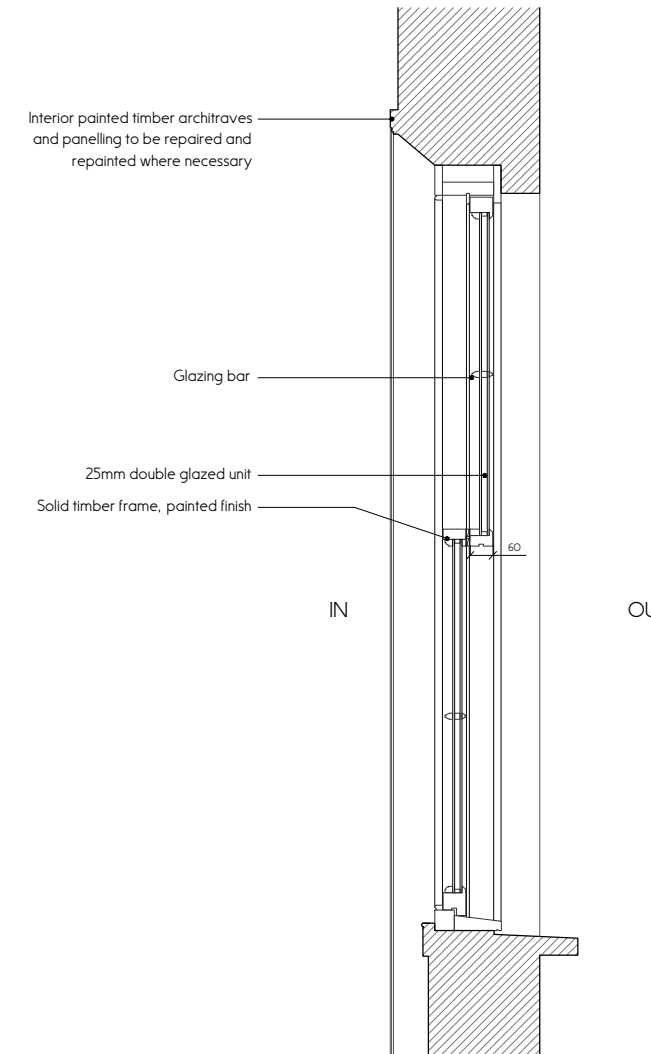

Section AA

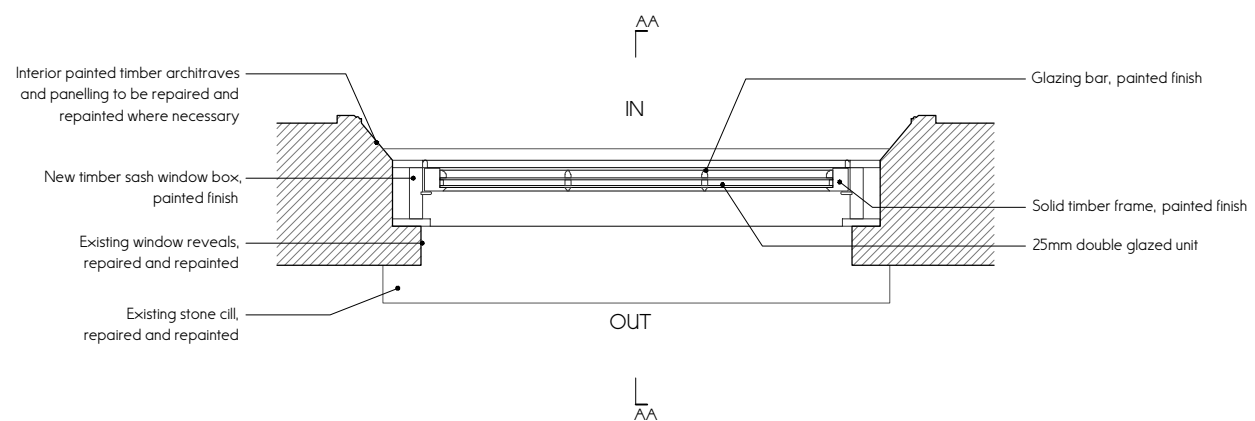

Plan

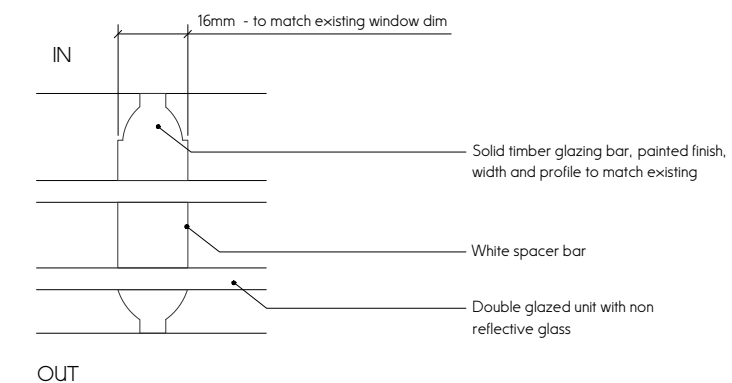

Section through glazing bar, scale 1:1

Drawn JL
 Checked -
 Scale 1:20 @ A3

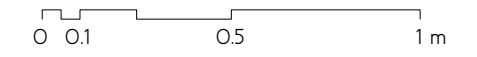

This drawing is to be read in conjunction with all other contract documents and specifications and all other consultants drawings. All levels and dimensions should be checked on site and any discrepancies notified to OMMX prior to proceeding with works. No drawing should be reproduced in any form without prior written permission from OMMX.

OMMX
 E25, Cockpit Arts
 Northington Street
 London WC1N 2NP

+44 (0)20 7405 5484
 www.officemmx.com

Project No. 17 Falkland Road
 0110

Client Charles Emmerson

Drawing Title Proposed 2nd Floor
 Rear Window
 Drawing No. 2.63

Revision	Date	Description
-	-----	For Planning
A	20.09.20	Glazing bar details added

Notes

Key Plan

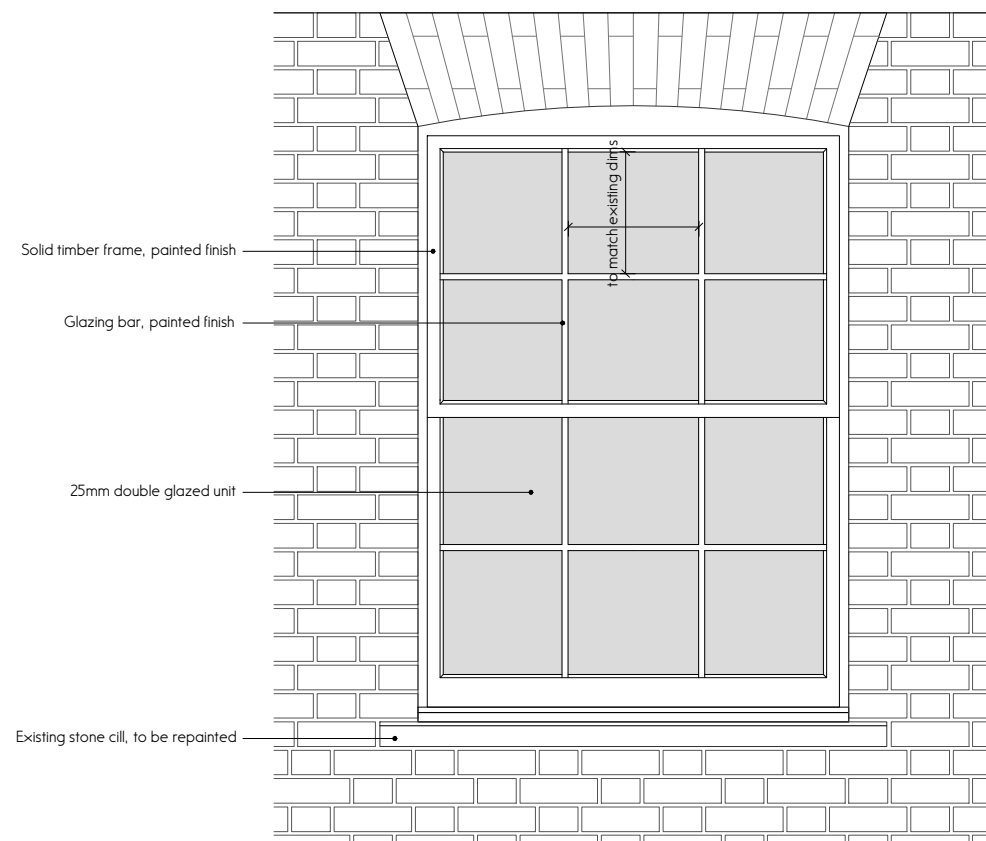
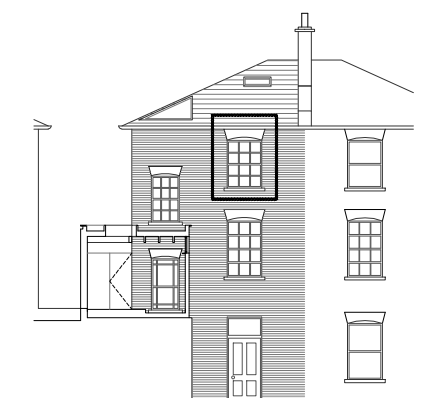

Elevation

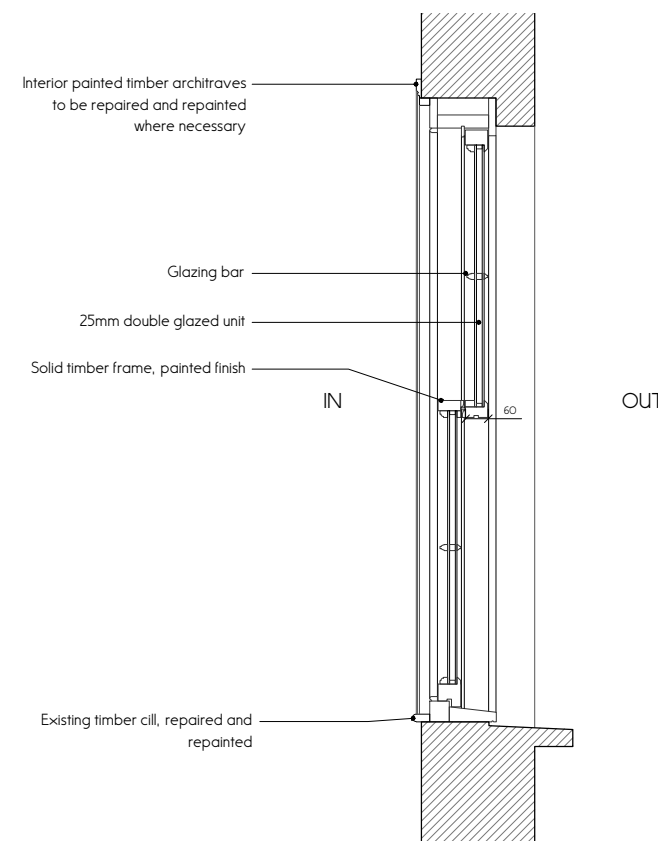

Section AA

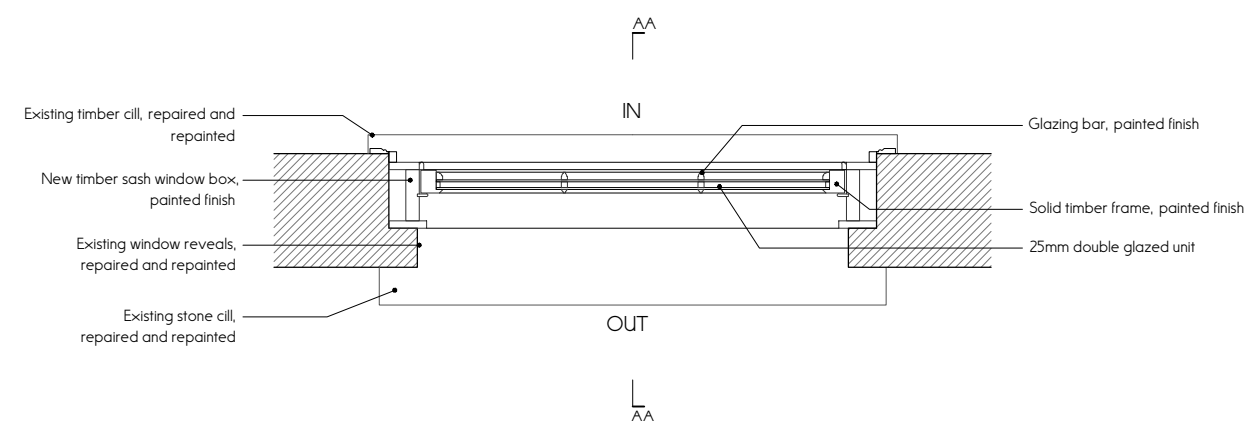

Plan

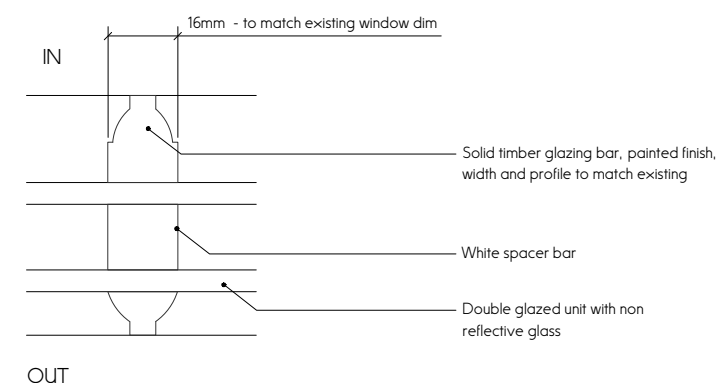

Section through glazing bar, scale 1:1

Drawn JL
 Checked -
 Scale 1:20 @ A3

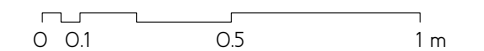

This drawing is to be read in conjunction with all other contract documents and specifications and all other consultants drawings. All levels and dimensions should be checked on site and any discrepancies notified to OMMX prior to proceeding with works. No drawing should be reproduced in any form without prior written permission from OMMX.