

**1 TYPICAL SG ELEVATION - W2.06-28**  
6232 1:10 @ AI

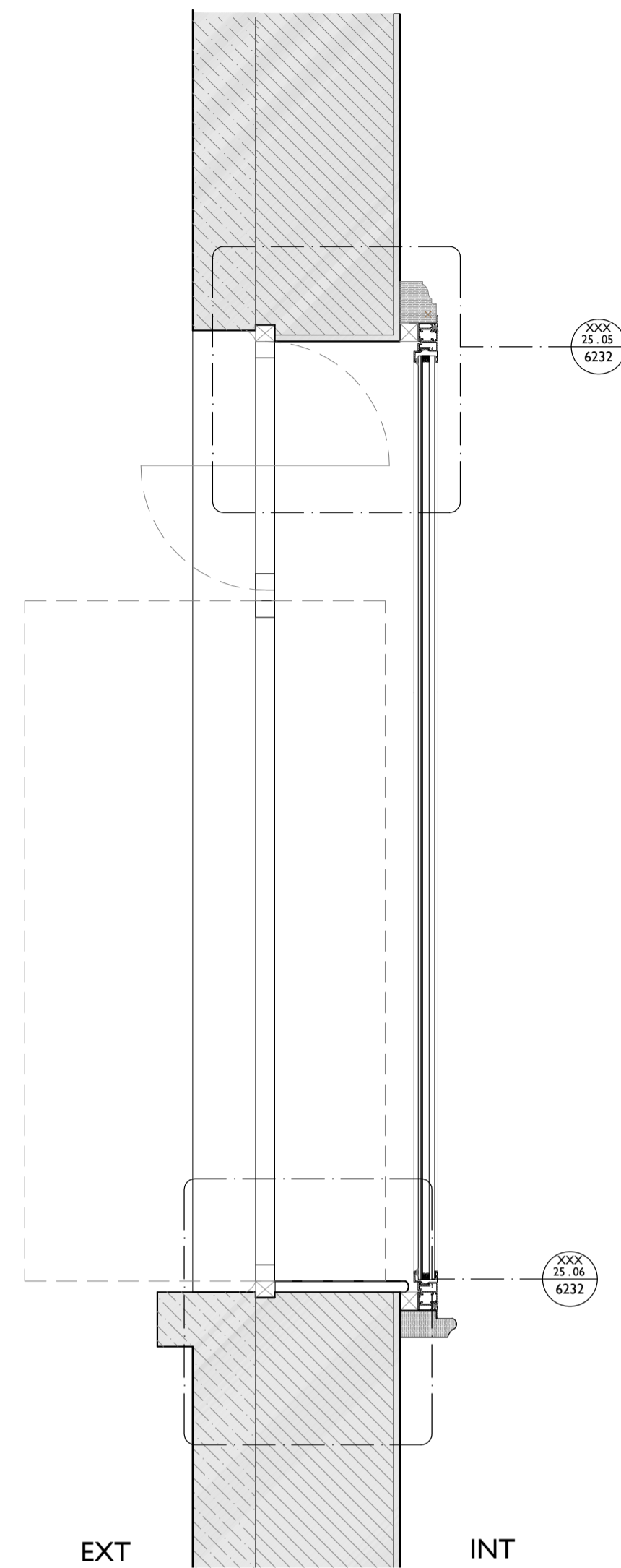

**3 TYPICAL SG SECTION - W2.06-28**  
6232 1:10 @ AI

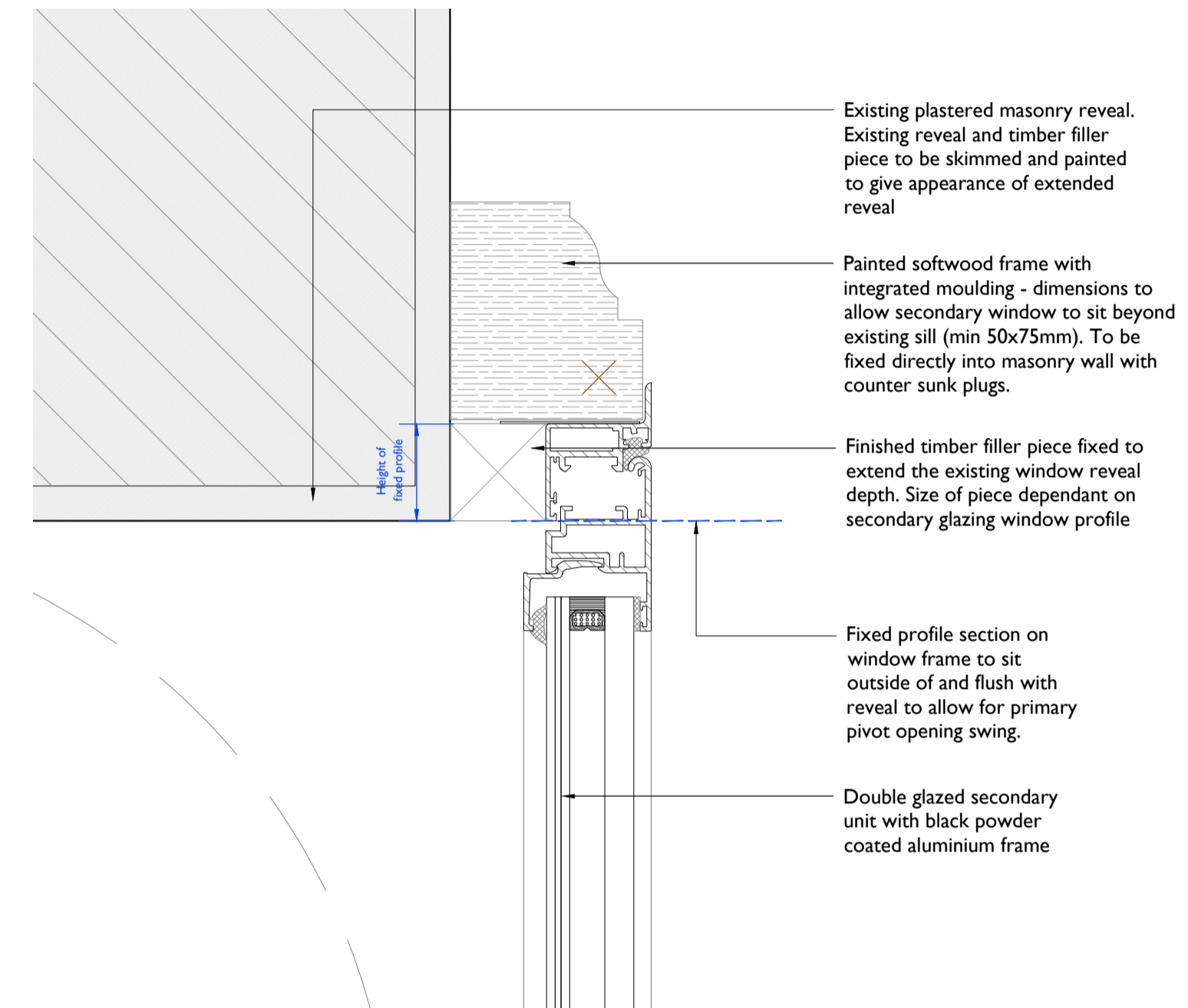

**5 TYPICAL HEAD DETAIL**  
6232 1:2 @ AI

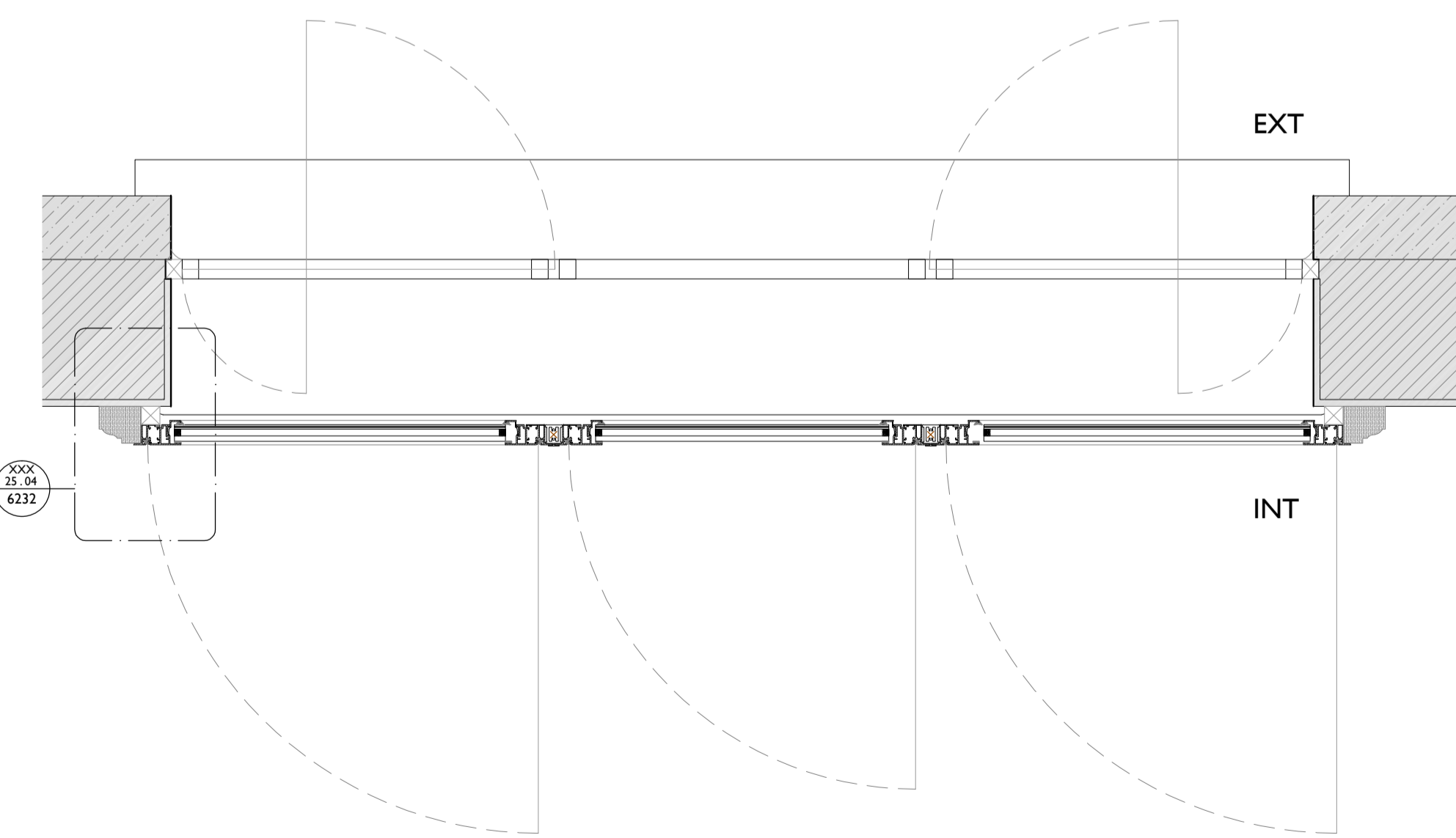

**2 TYPICAL SG PLAN - W2.06-28**  
6232 1:10 @ AI

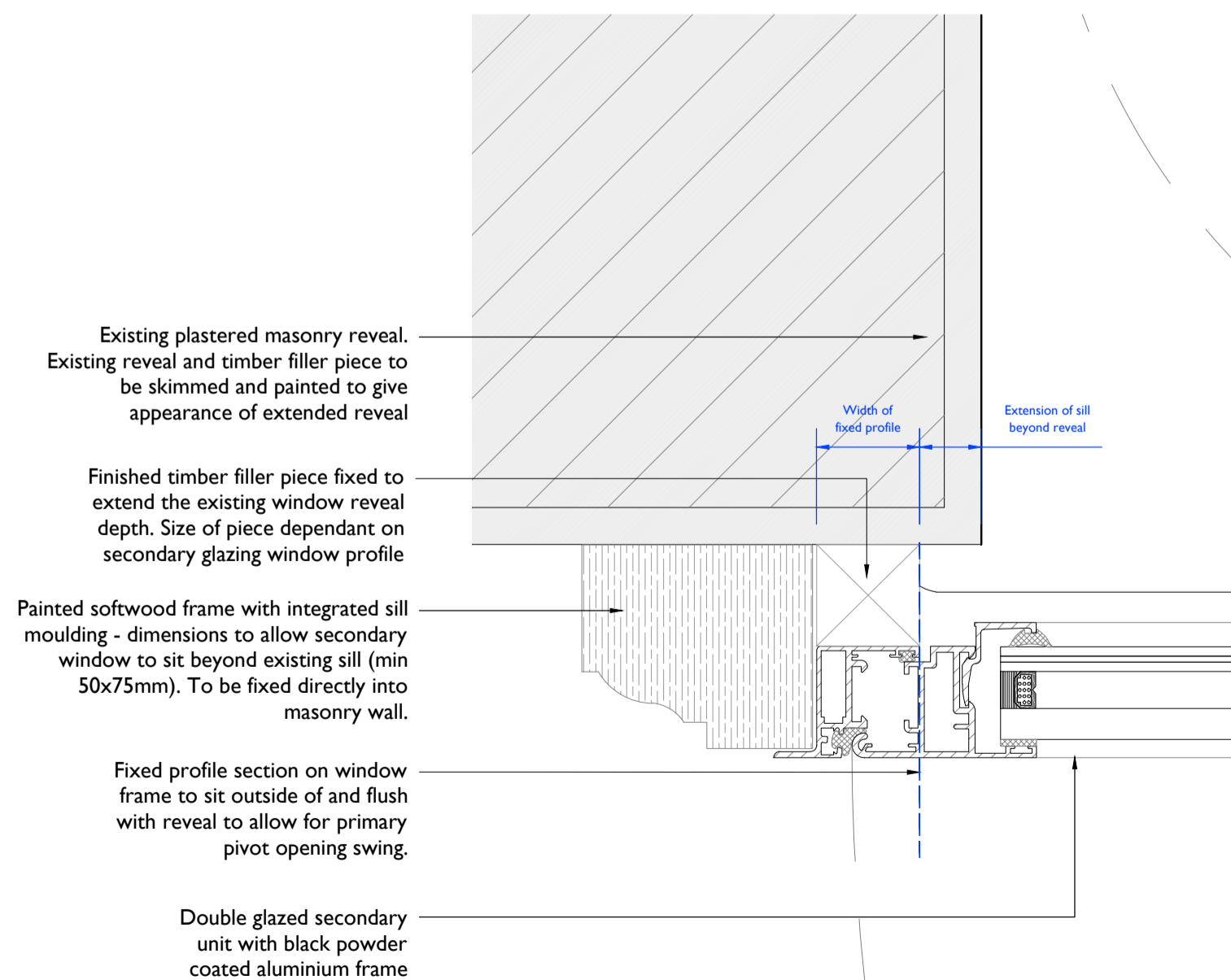

**4 TYPICAL JAM DETAIL**  
6232 1:2 @ AI

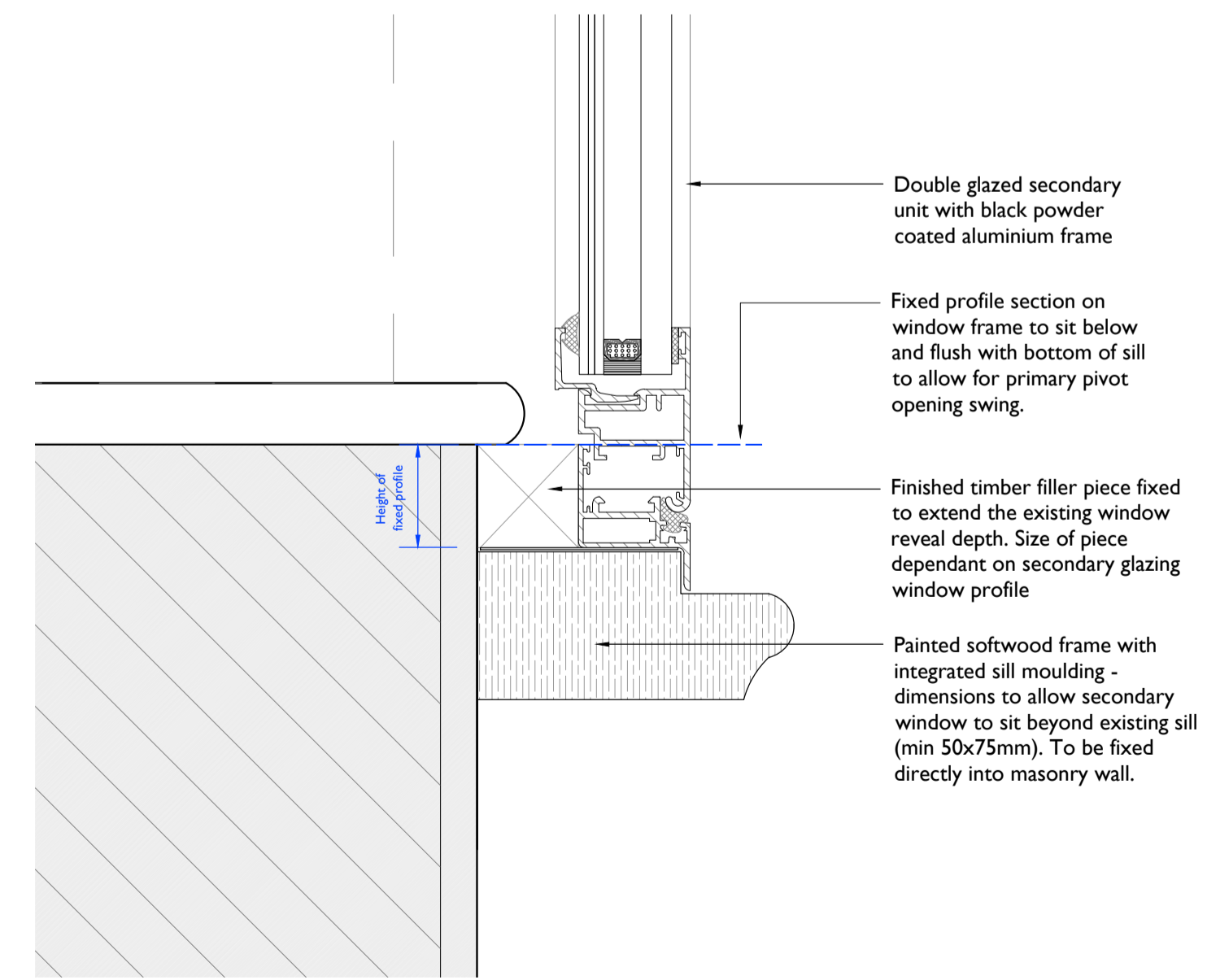

**6 TYPICAL SILL DETAIL**  
6232 1:2 @ AI

**Notes:**  
Drawings are based on survey data and may not accurately represent what is physically present.  
Do not scale from this drawing. All dimensions are to be verified on site before proceeding with the work.  
All dimensions are in millimeters unless noted otherwise.  
Purcell shall be notified in writing of any discrepancies.

**TYPICAL SECONDARY GLAZING TYPE**  
**DOUBLE GLAZED, NON THERMALLY BROKEN, ALUMINIUM**  
**3No. FULL HEIGHT INWARD OPENING SIDE HUNG CASEMENTS. FACE FIXED TO REVEAL (WITH EXISTING SILL)**  
Fixed profile to sit outside of reveal allowing primary window pivot swing.

**Note:**  
All window drawings to be read in conjunction with Building Envelope Specification CTH-AKT-XXX-SP-25-R-003 Window Schedule CTH-PUR-XXX-SCH-25-A-7101 Window Strategy CTH-PUR-XXX-RP-25-A-7001  
Primary window and existing wall build up shown indicatively. Refer to Building Envelope Specification and Window Schedule for proposed works to primary windows.

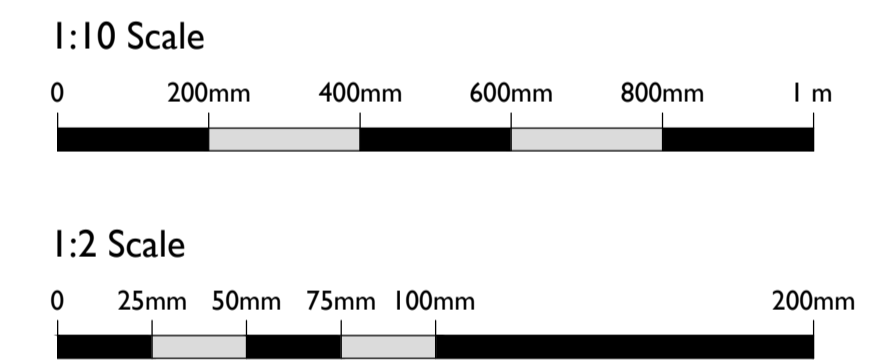

T00	30 Sep 2019	OB	NS
	19 Jul 2019	nicolasmith	
First Issue	19 Jul 2019	NS	NS

ISSUE	DATE	DRAWN	CHECKED	DESCRIPTION
<b>DRAWING TITLE</b>	Typical Secondary Glazing Details			
<b>DRAWING NO.</b>	CTH-PUR-XXX-DR-25-A-6232			
<b>REVISION</b>	T00			
<b>SIZE &amp; SCALE</b>	A1L 1:2 @A1			

**DRAWING STATUS** ISSUED FOR TENDER

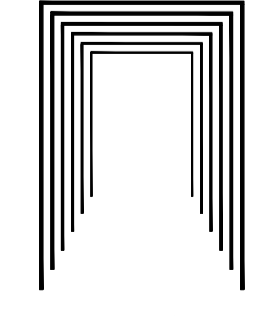
<b>CLIENT</b>	Lendlease	
<b>PROJECT</b>	Camden Town Hall	
<b>JOB NUMBER</b>	238664	