

Plan  
1:20 @ A1

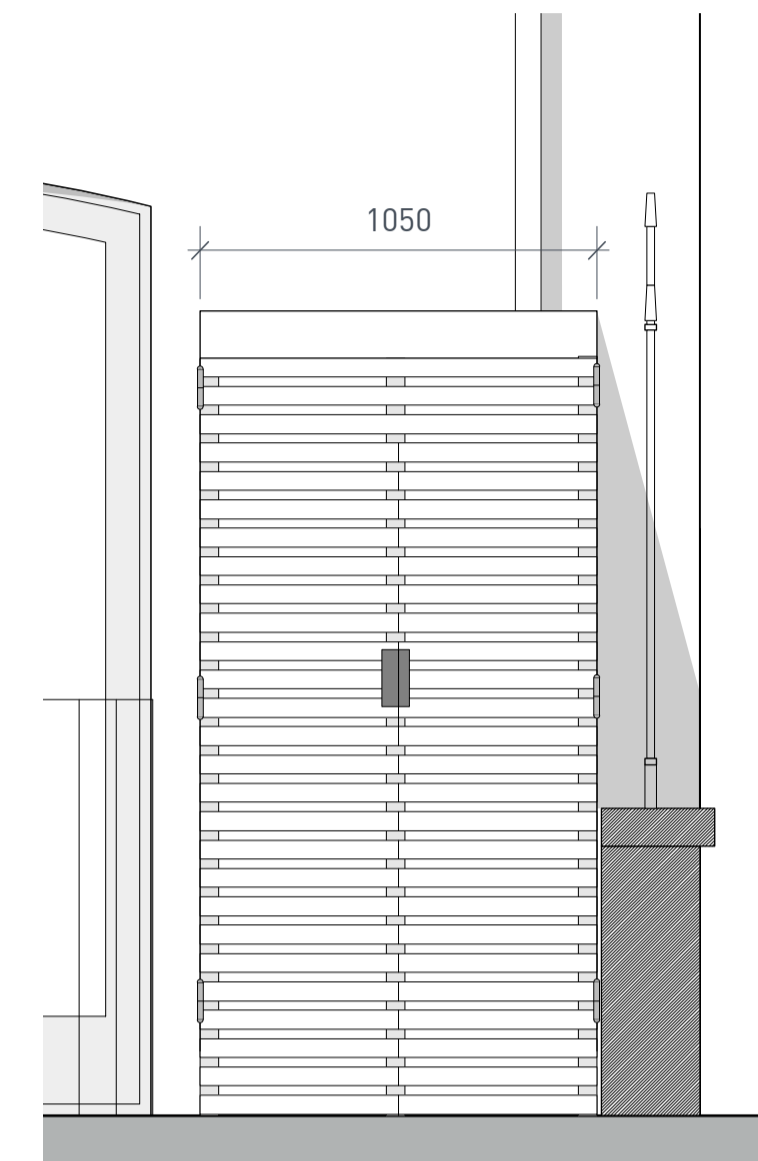

Bike Stand Detail  
1:20 @ A1

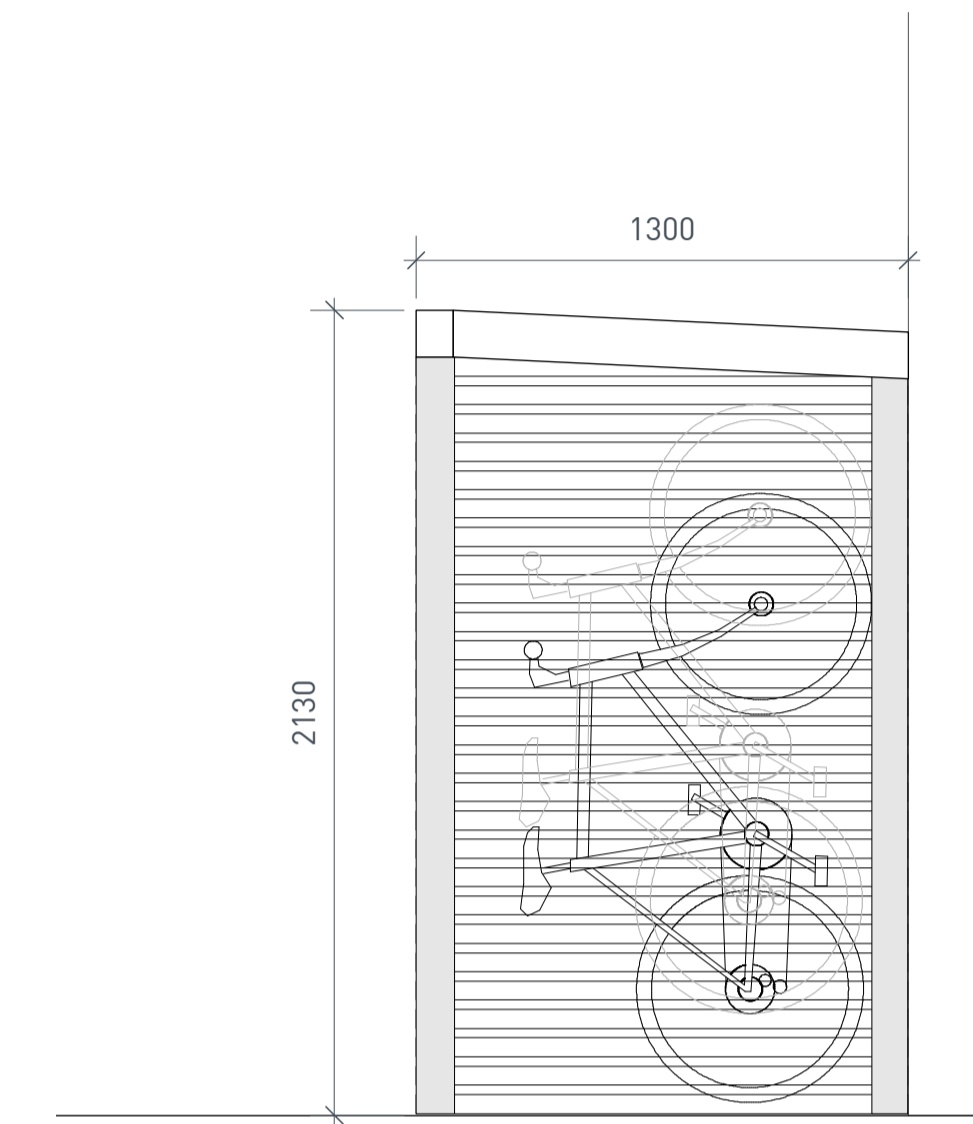

Bike Stand Detail  
1:20 @ A1

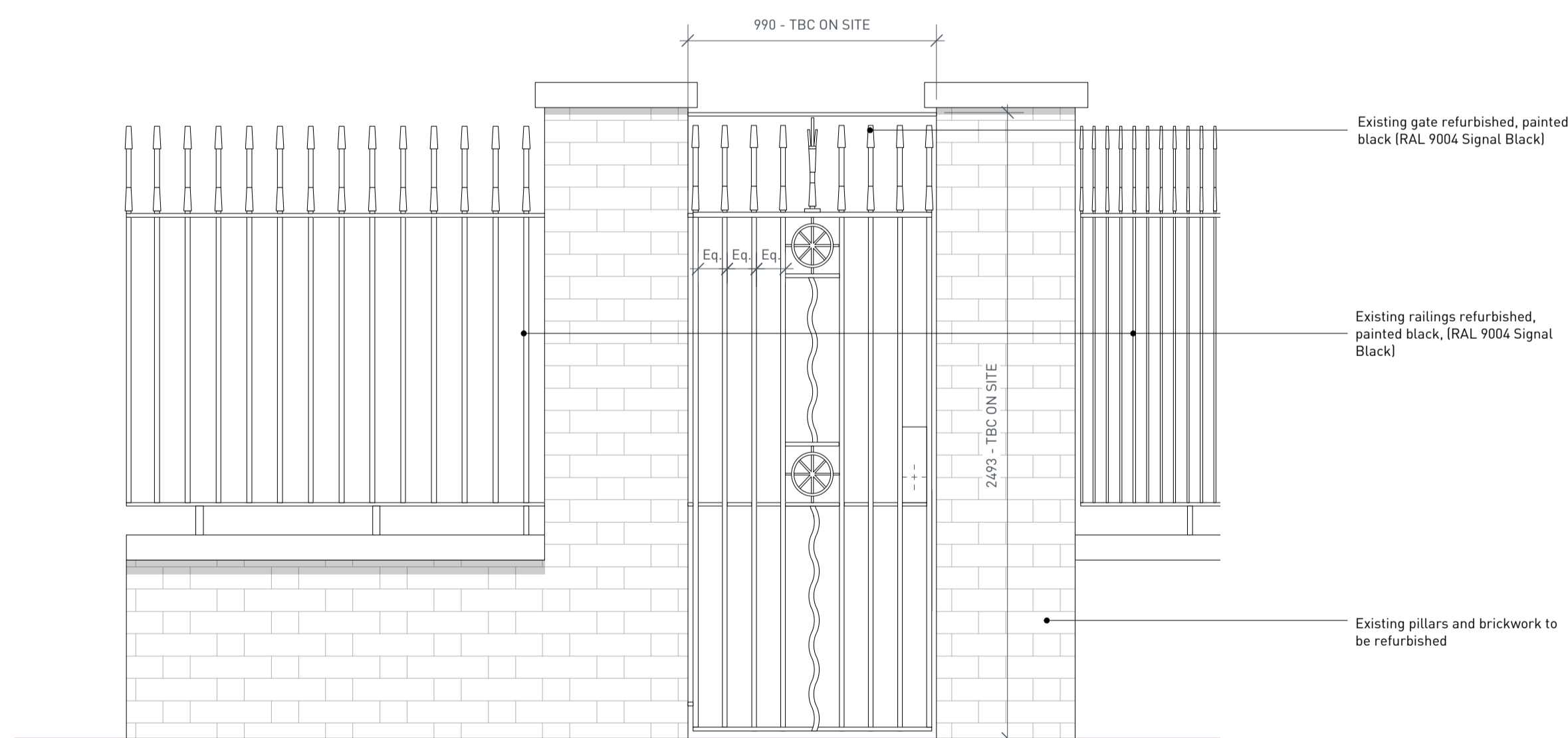

ELEVATION 01  
1:20 @ A1

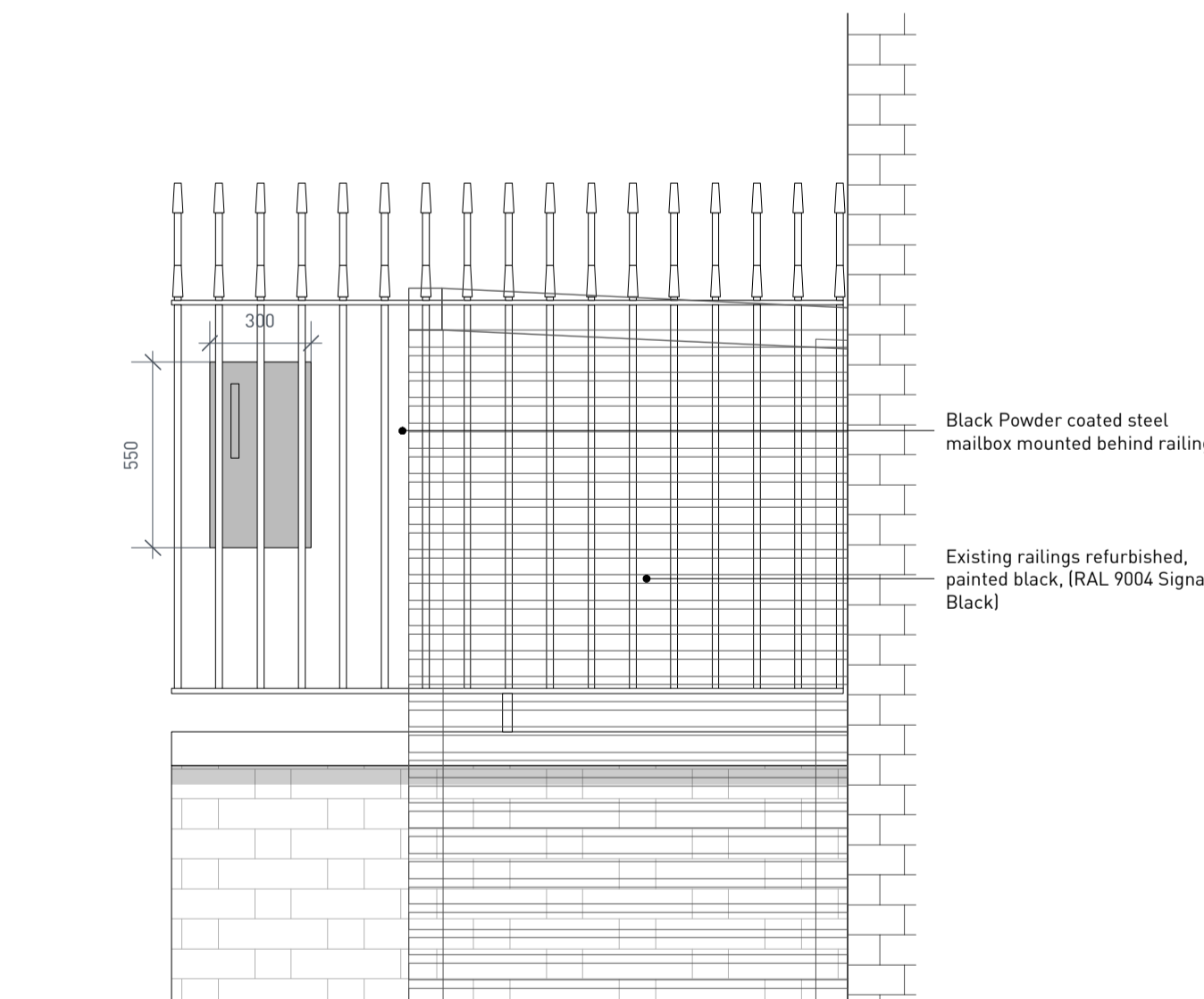

ELEVATION 02  
1:20 @ A1

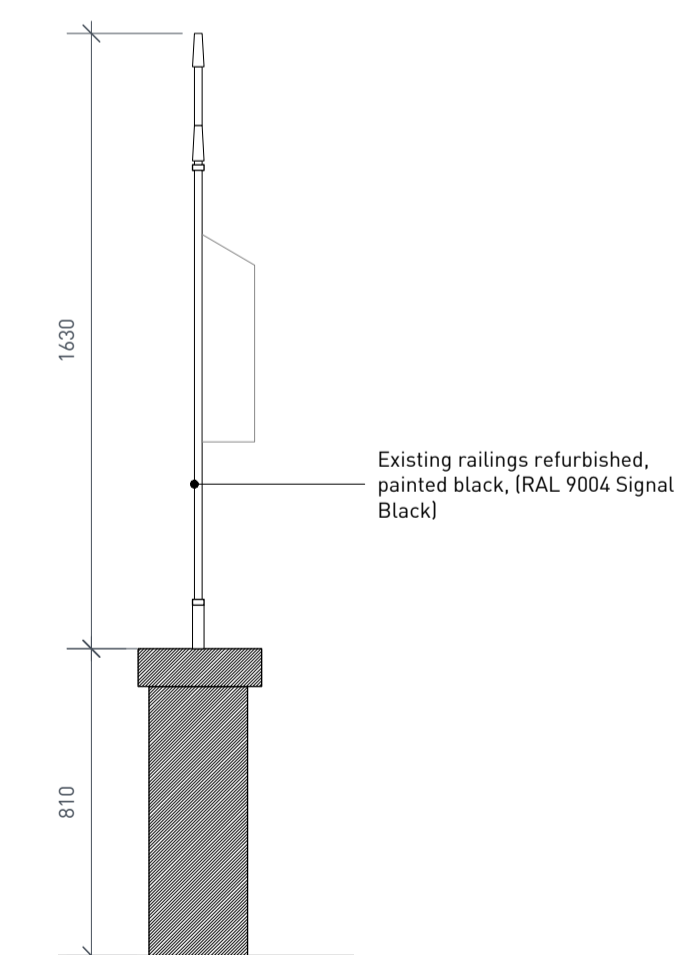

SECTION AA  
1:20 @ A1

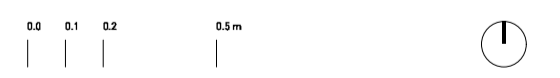

121 SALISBURY ROAD  
LONDON NW6 6RD  
info@claridgearchitects.com  
+44(0)20 8969 9223

This drawing is the property of Claridge Architects Ltd. Copyright is reserved & this drawing is issued on the condition that it is not copied, reproduced, retained or disclosed to any unauthorised person, either wholly or in part, without our consent. Do not scale from this drawing. Check all dimensions on site.

22 TOWER STREET  
CLIENT - BRITISH RETAIL CONSORTIUM

TOWER COURT FENCE  
STATUS - PLANNING

DRAWN	CHECKED	REVISION
BS	-	-
SCALE	DRAWING	DATE
1:20 @ A1	18010..ES.01	24.06.20