

- Notes**
1. Do not scale this drawing.
 2. All dimensions must be checked on site and any discrepancies verified with the architect.
 3. Unless shown otherwise, all dimensions are to structural surfaces.
 4. Drawing to be read with all other issued information and any discrepancies to be brought to the attention of the architect.
 5. This drawing is the copyright of Levitt Bernstein and may not be copied, altered or reproduced in any form, or passed to a third party without license or written consent.
- This is not a construction drawing, it is unsuitable for the purpose of construction and must on no account be used as such.

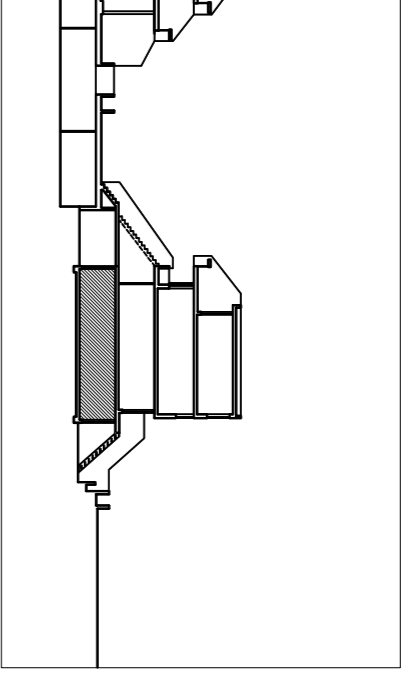

Block B Section Key

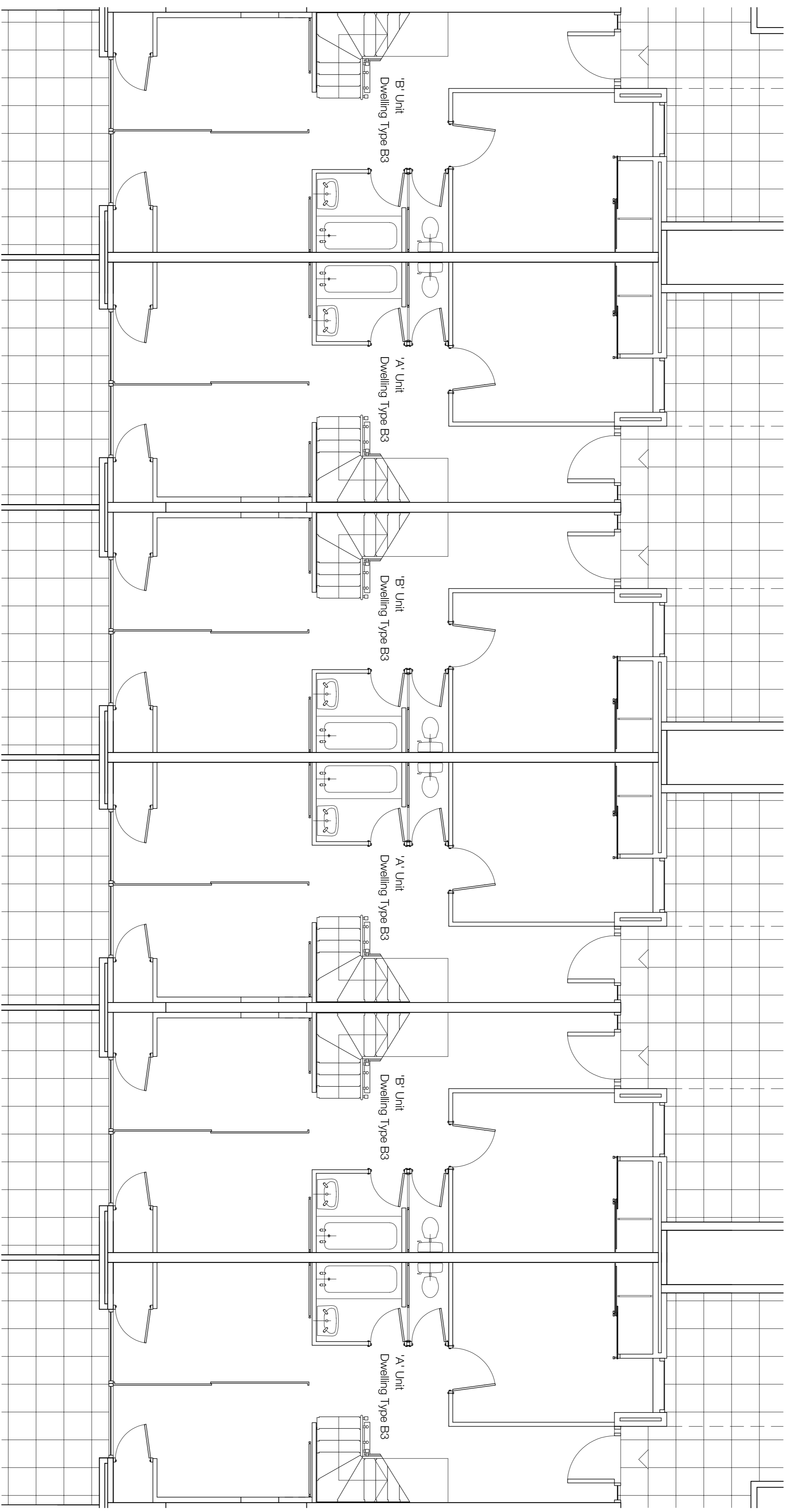

01 Block B Level 03 - Typical

Project name
P1 20/03/20 - Planning & Listed Building Consent
Rev Date
Description
Title

Author
DT

Client
Camden CC

Checked
NM

Date
20/03/20

Drawn
DT

Scale
1:50 @ A1

Purpose of Issue
PLANNING

Block B
Dwelling Type B3 - Existing

Drawing
3467_LB_103015

Rev
P1

Drawing number
3467_LB_103015

Rev
P1

Project name
P1 20/03/20 - Planning & Listed Building Consent

Rev Date
Description

Title
DT

Author
DT

Client
Camden CC

Checked
NM

Date
20/03/20

Drawn
DT

Scale
1:50 @ A1

Purpose of Issue
PLANNING

Block B
Dwelling Type B3 - Existing

Drawing
3467_LB_103015

Rev
P1

Drawing number
3467_LB_103015

Rev
P1

Project name
P1 20/03/20 - Planning & Listed Building Consent

Rev Date
Description

Title
DT

Author
DT

Client
Camden CC

Checked
NM

Date
20/03/20

Drawn
DT

Scale
1:50 @ A1

Purpose of Issue
PLANNING

Block B
Dwelling Type B3 - Existing

Drawing
3467_LB_103015

Rev
P1

Drawing number
3467_LB_103015

Rev
P1

Project name
P1 20/03/20 - Planning & Listed Building Consent

Rev Date
Description

Title
DT

Author
DT

Client
Camden CC

Checked
NM

Date
20/03/20

Drawn
DT

Scale
1:50 @ A1

Purpose of Issue
PLANNING

Block B
Dwelling Type B3 - Existing

Drawing
3467_LB_103015

Rev
P1

Drawing number
3467_LB_103015

Rev
P1

Project name
P1 20/03/20 - Planning & Listed Building Consent

Rev Date
Description

Title
DT

Author
DT

Client
Camden CC

Checked
NM

Date
20/03/20

Drawn
DT

Scale
1:50 @ A1

Purpose of Issue
PLANNING

Block B
Dwelling Type B3 - Existing

Drawing
3467_LB_103015

Rev
P1

Drawing number
3467_LB_103015

Rev
P1

Project name
P1 20/03/20 - Planning & Listed Building Consent

Rev Date
Description

Title
DT

Author
DT

Client
Camden CC

Checked
NM

Date
20/03/20

Drawn
DT

Scale
1:50 @ A1

Purpose of Issue
PLANNING

Block B
Dwelling Type B3 - Existing

Drawing
3467_LB_103015

Rev
P1

Drawing number
3467_LB_103015

Rev
P1

Project name
P1 20/03/20 - Planning & Listed Building Consent

Rev Date
Description

Title
DT

Author
DT

Client
Camden CC

Checked
NM

Date
20/03/20

Drawn
DT

Scale
1:50 @ A1

Purpose of Issue
PLANNING

Block B
Dwelling Type B3 - Existing

Drawing
3467_LB_103015

Rev
P1

Drawing number
3467_LB_103015

Rev
P1

Project name
P1 20/03/20 - Planning & Listed Building Consent

Rev Date
Description

Title
DT

Author
DT

Client
Camden CC

Checked
NM

Date
20/03/20

Drawn
DT

Scale
1:50 @ A1

Purpose of Issue
PLANNING

Block B
Dwelling Type B3 - Existing

Drawing
3467_LB_103015

Rev
P1

Drawing number
3467_LB_103015

Rev
P1

Project name
P1 20/03/20 - Planning & Listed Building Consent

Rev Date
Description

Title
DT

Author
DT

Client
Camden CC

Checked
NM

Date
20/03/20

Drawn
DT

Scale
1:50 @ A1

Purpose of Issue
PLANNING

Block B
Dwelling Type B3 - Existing

Drawing
3467_LB_103015

Rev
P1

Drawing number
3467_LB_103015

Rev
P1

Project name
P1 20/03/20 - Planning & Listed Building Consent

Rev Date
Description

Title
DT

Author
DT

Client
Camden CC

Checked
NM

Date
20/03/20

Drawn
DT

Scale
1:50 @ A1

Purpose of Issue
PLANNING

Block B
Dwelling Type B3 - Existing

Drawing
3467_LB_103015

Rev
P1

Drawing number
3467_LB_103015

Rev
P1

Project name
P1 20/03/20 - Planning & Listed Building Consent

Rev Date
Description

Title
DT

Author
DT

Client
Camden CC

Checked
NM

Date
20/03/20

Drawn
DT

Scale
1:50 @ A1

Purpose of Issue
PLANNING

Block B
Dwelling Type B3 - Existing

Drawing
3467_LB_103015

Rev
P1

Drawing number
3467_LB_103015

Rev
P1

Project name
P1 20/03/20 - Planning & Listed Building Consent

Rev Date
Description

Title
DT

Author
DT

Client
Camden CC

Checked
NM

Date
20/03/20

Drawn
DT

Scale
1:50 @ A1

Purpose of Issue
PLANNING

Block B
Dwelling Type B3 - Existing

Drawing
3467_LB_103015

Rev
P1

Drawing number
3467_LB_103015

Rev
P1

Project name
P1 20/03/20 - Planning & Listed Building Consent

Rev Date
Description

Title
DT

Author
DT

Client
Camden CC

Checked
NM

Date
20/03/20

Drawn
DT

Scale
1:50 @ A1

Purpose of Issue
PLANNING

Block B
Dwelling Type B3 - Existing

Drawing
3467_LB_103015

Rev
P1

Drawing number
3467_LB_103015

Rev
P1

Project name
P1 20/03/20 - Planning & Listed Building Consent

Rev Date
Description

Title
DT

Author
DT

Client
Camden CC

Checked
NM

Date
20/03/20

Drawn
DT

Scale
1:50 @ A1

Purpose of Issue
PLANNING

Block B
Dwelling Type B3 - Existing

Drawing
3467_LB_103015

Rev
P1

Drawing number
3467_LB_103015

Rev
P1

Project name
P1 20/03/20 - Planning & Listed Building Consent

Rev Date
Description

Title
DT

Author
DT

Client
Camden CC

Checked
NM

Date
20/03/20

Drawn
DT

Scale
1:50 @ A1

Purpose of Issue
PLANNING

Block B
Dwelling Type B3 - Existing

Drawing
3467_LB_103015

Rev
P1

Drawing number
3467_LB_103015

Rev
P1

Project name
P1 20/03/20 - Planning & Listed Building Consent

Rev Date
Description

Title
DT

Author
DT

Client
Camden CC

Checked
NM

Date
20/03/20

Drawn
DT

Scale
1:50 @ A1

Purpose of Issue
PLANNING

Block B
Dwelling Type B3 - Existing

Drawing
3467_LB_103015

Rev
P1

Drawing number
3467_LB_103015

Rev
P1

Project name
P1 20/03/20 - Planning & Listed Building Consent

Rev Date
Description

Title
DT

Author
DT

Client
Camden CC

Checked
NM

Date
20/03/20

Drawn
DT

Scale
1:50 @ A1

Purpose of Issue
PLANNING

Block B
Dwelling Type B3 - Existing

Drawing
3467_LB_103015

Rev
P1

Drawing number
3467_LB_103015

Rev
P1

Project name
P1 20/03/20 - Planning & Listed Building Consent

Rev Date
Description

Title
DT

Author
DT

Client
Camden CC

Checked
NM

Date
20/03/20

Drawn
DT

Scale
1:50 @ A1

Purpose of Issue
PLANNING

Block B
Dwelling Type B3 - Existing

Drawing
3467_LB_103015

Rev
P1

Drawing number
3467_LB_103015

Rev
P1

Project name
P1 20/03/20 - Planning & Listed Building Consent

Rev Date
Description

Title
DT</