

TOSHIBA

Leading Innovation >>>



TOSHIBA AIRCONDITIONING

Advancing the **eco**-evolution

TOSHIBA Design
AIRS

KIDDEPORE HALL
WATKINS

17-May-19

Revision: REV 5



Toshiba Design **AIRS** - Project Quotation

Client:	WATKINS
To:	KEITH NICHOLLS
Tel:	
Email:	

Project Name:	KIDDEPORE HALL
Quote No.	0
Quote Ref.	
Quote Revision:	0

Site Name:	
Contact:	
Tel:	
Email:	

Project:	KIDDEPORE HALL
Project Ref:	WATKINS
Project Revision:	REV 5

Client Address:

Site Address:

Address:
Dublin D24



Toshiba DesignAIRS - Index

KIDDEPORE HALL

Project Quotation	1
Index	2
Project Notes	3
Project Compliance	4
System 1	6
System 1 Equipment List	6
System 1 Details	8
System 1 Schematic	10
System 1 FloorPerspective3D	14
Piping Diagram	15
Sales Data	17
Dimensions	17
Sound NC Curve	20



Toshiba DesignAIRS - Project Notes

KIDDEPORE HALL

Notes: Equivalent length is calculated by coefficients:

□* 1.2: System 1

The user is responsible for ensuring that all data entered is correct,

It is the responsibility of the consultant or contractor, to verify and confirm that the equipment selection and system design is correct before installation.

Please note that in the event of future system expansion being allowed for in the system design or a change in cooling/heating requirements, a re-evaluation of the air conditioning system must be made prior to final installation.



Toshiba DesignAIRS - Project Compliance

KIDDEPORE HALL Compliance

System 1

Rules	Specification	Design	Ok
Height between outdoor units in range	5 m	0 m	✓
Max number of indoor units	36	19	✓
Height between indoor units in range	40 m	7 m	✓
Indoor unit below outdoor unit heights in range	30 m		✓
Indoor unit above outdoor unit heights in range	50 m		✓
Header Maximum Total Downstream Capacity Code	25.2		✓
Header Maximum Pipeline Downstream Capacity Code	6		✓
End Cap maximum capacity exceeded			✓
PVM to indoor unit in range	2 m - 10 m	-	✓
Remote Controller Incompatibility (RBC-AMS51E/54E)			✓
Concentration limit exceeded	0.44 kg/m ³	0 kg/m ³	✓
Total refrigerant limit exceeded	140 kg	30.29 kg	✓
Indoor DB (Cooling) temperature range	18°C - 32°C	23°C	✓
Indoor DB (Cooling) temperature range	15°C - 24°C	16°C	✓
Indoor RH (Cooling) temperature range	20 - 80	47	✓
Indoor DB (Heating) temperature range	15°C - 28°C	21°C	✓
Outdoor DB (Cooling) temperature range	-5°C - 46°C	30°C	✓
Outdoor WB (Heating) temperature range	-20°C - 15.5°C	-4.2°C	✓
Capacity ratio in range	50.0% - 135.0%	125.3%	✓
Main piping equivalent length	120 m	23.4 m	✓
Main piping real length	100 m	19.5 m	✓
Piping between branches equivalent length	50 m	8.4 m	✓
Total pipe length	300 m	157.5 m	✓
Farthest Equivalent Piping Length	185 m	60 m	✓
Farthest Real Piping Length	145 m	50 m	✓
Farthest Equivalent Piping Length From First Branch	65 m	36.6 m	✓
Farthest Equivalent Piping Length Between Outdoor_Units	25 m	0 m	✓
Greatest Outdoor Unit Connecting Piping Equivalent Length	10 m	0 m	✓
Central Controls			✓

Overall System 1

✓



Toshiba Design **AIRS** - Project Compliance





Toshiba Design AIRS - System Equipment List

System 1 Equipment List

Outdoor Unit

Model name	Header	Follower 1	Follower 2	Follower 3
MMY-MAP1606HT8P-E	MMY-MAP1606HT8P-E			

Indoor Units

Model name	Description	Quantity
MMD-AP0076BHP1-E	0.8HP Standard Concealed Duct	5
MMD-AP0096BHP1-E	1.0HP Standard Concealed Duct	4
MMD-AP0126BHP1-E	1.25HP Standard Concealed Duct	9
MMK-AP0077HP-E	0.8HP High Wall Compact	1

Y joints

Model name	Description	Quantity
RBM-BY55E	Y Joint	14
RBM-BY105E	Y Joint	3
RBM-BY205E	Y Joint	1

Accessories

Model name	Description	Quantity
RBC-AS41E	Simplified Wired RC	10

Piping Length

Pipe Diameter	Gas side (m)	Discharge side (m)	Liquid side (m)	Total Length (m)
¼ "	0	0	62.5	62.5
⅜ "	62.5	0	65.5	128
½ "	26	0	9	35
⅝ "	39.5	0	20.5	60
⅞ "	9	0	0	9
1 ⅛ "	20.5	0	0	20.5

Refrigerant Charge Amount

Refrigerant (R410A)	Description	Amount (kg)
Outdoor	Refrigerant amount charged in factory	11.5
Additional Refrigerant	Amount needed for the pipes at the site	18.79

Outdoor Design Temperature

Mode	Description	Temperature
Cooling	Dry bulb Temperature	30°C
Heating	Wet bulb Temperature	-4.2°C



Electric information (Outdoor Units)

Property	Description	Value
MOCAP (A)	Maximum Overcurrent Protection	40
MCA (A)	Minimum Circuit Amps	35.8
Protection Device size (A)		0
Wire (cable size) (mm ²) or AWG(#)		0

Electric information (Indoor Units)

Property	Description	Value
Total MCA (A)		5.22
Protection Devices size (A)		0
Wire (cable size) (mm ²) or AWG(#)		0



Toshiba Design AIRS - System Details

System 1 Details

Outdoor Unit Models

Model Name	Header	Follower 1	Follower 2	Follower 3
MMY-MAP1606HT8P-E	MMY-MAP1606HT8P-E			

Outdoor Unit

Model Name	Cooling (kW)		Heating (kW)		Diversity	
	Rated	Corrected	Rated	Corrected	System	Building
MMY-MAP1606HT8P-E	45.00	38.95	50.00	35.11	125.3%	25%

Indoor Units

Model Name	Unit Name & Room	Capacity Code	Fan Speed	Mode	Capacity (Total/Sensible) [kW]		
					Rated	Corrected	Required
MMD-AP0076BHP1-E	MASTER BEDROO..	0.8HP	High	Cooling	2.20/1.80	1.81/1.53	2.04/0.00
				Heating	2.50	1.71	
MMD-AP0076BHP1-E	MASTER BEDROO..	0.8HP	High	Cooling	2.20/1.80	1.83/1.54	2.04/0.00
				Heating	2.50	1.72	
MMD-AP0076BHP1-E	FCU16	0.8HP	High	Cooling	2.20/1.80	1.82/1.53	
				Heating	2.50	1.71	
MMD-AP0076BHP1-E	FCU18	0.8HP	High	Cooling	2.20/1.80	1.83/1.54	
				Heating	2.50	1.72	
MMD-AP0076BHP1-E	BED 3 FCU12	0.8HP	High	Cooling	2.20/1.80	1.79/1.51	
				Heating	2.50	1.70	
MMD-AP0096BHP1-E	FCU01	1.0HP	High	Cooling	2.80/2.30	2.38/2.01	2.16/0.00
				Heating	3.20	2.21	
MMD-AP0096BHP1-E	FCU07	1.0HP	High	Cooling	2.80/2.30	2.39/2.02	
				Heating	3.20	2.22	
MMD-AP0096BHP1-E	BED 4 FCU13	1.0HP	High	Cooling	2.80/2.30	2.37/2.01	
				Heating	3.20	2.21	
MMD-AP0096BHP1-E	FCU17	1.0HP	High	Cooling	2.80/2.30	2.30/1.95	
				Heating	3.20	2.19	
MMD-AP0126BHP1-E	MASTER DRESSIN..	1.25HP	High	Cooling	3.60/2.70	3.08/2.38	4.00/0.00
				Heating	4.00	2.78	
MMD-AP0126BHP1-E	FCU05	1.25HP	High	Cooling	3.60/2.70	3.12/2.42	3.10/0.00
				Heating	4.00	2.79	
MMD-AP0126BHP1-E	FCU3	1.25HP	High	Cooling	3.60/2.70	3.03/2.35	3.00/0.00
				Heating	4.00	2.76	
MMD-AP0126BHP1-E	FCU4	1.25HP	High	Cooling	3.60/2.70	3.05/2.36	3.00/0.00
				Heating	4.00	2.77	
MMD-AP0126BHP1-E	FCU6	1.25HP	High	Cooling	3.60/2.70	2.96/2.29	4.00/0.00
				Heating	4.00	2.73	
MMD-AP0126BHP1-E	FCU02	1.25HP	High	Cooling	3.60/2.70	2.96/2.29	2.60/0.00
				Heating	4.00	2.73	



Toshiba Design **AIRS** - System Details

Indoor Units

Model Name	Unit Name & Room	Capacity Code	Fan Speed	Mode	Capacity (Total/Sensible) [kW]		
					Rated	Corrected	Required
MMD-AP0126BHP1-E	FCU18	1.25HP	High	Cooling	3.60/2.70	2.99/2.32	
				Heating	4.00	2.75	
MMD-AP0126BHP1-E	FCU19	1.25HP	High	Cooling	3.60/2.70	2.98/2.31	
				Heating	4.00	2.74	
MMD-AP0126BHP1-E	BED 2 FCU11	1.25HP	High	Cooling	3.60/2.70	2.95/2.28	
				Heating	4.00	2.73	
MMK-AP0077HP-E	STORE RM	0.8HP	High	Cooling	2.20/1.70	1.80/1.44	
				Heating	2.50	1.71	

System 1

Floor: LG

Elevation: 1m below Outdoor Unit

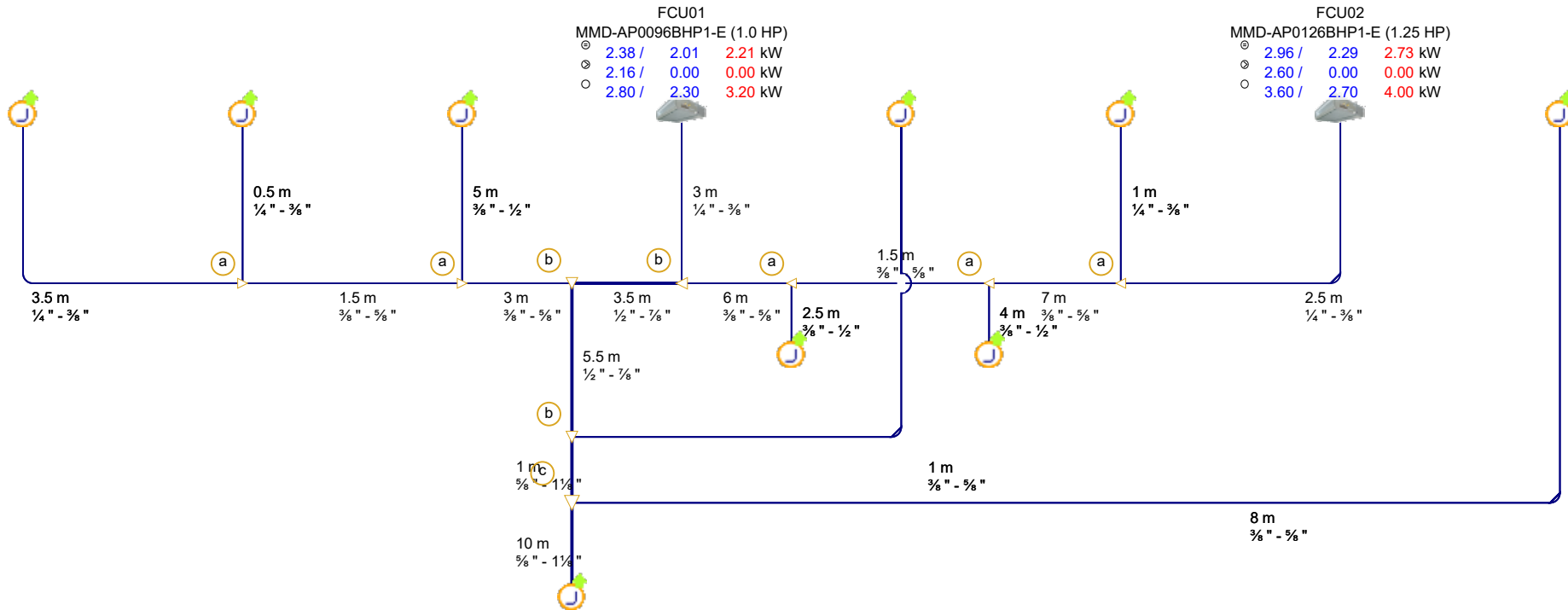

System Information

Indoor Units	19 of 36
Capacity	125.3%
Total Pipe Length	157.5 m
Indoor Cap. Tot./Sen.	47.44 kW/38.09 kW
Indoor Cap. Heat.	43.88 kW
Building diversity	25%

Outdoor/Indoor Legend

Model Name (Capacity Code)	
*Room name	
⊖	Corrected Capacity Tot./Sens./ Heat.
⊗	Required Capacity Tot./Sens./ Heat.
○	Rated Capacity Tot./Sens./ Heat.

Piping Legend

Actual Length
Liquid / Suction Gas diameters
Note: It is the responsibility of the consultant or contractor, to verify and confirm that the equipment selection and system design is correct before installation.

Branches Legend

a	RBM-BY55E	(x14)
b	RBM-BY105E	(x3)
c	RBM-BY205E	(x1)

System 1

Floor: Ground

Elevation: 0m

System Information	
Indoor Units	19 of 36
Capacity	125.3%
Total Pipe Length	157.5 m
Indoor Cap. Tot./Sen.	47.44 kW/38.09 kW
Indoor Cap. Heat.	43.88 kW
Building diversity	25%

Outdoor/Indoor Legend	
Model Name (Capacity Code)	
*Room name	
⊖	Corrected Capacity Tot./Sens./ Heat.
⊕	Required Capacity Tot./Sens./ Heat.
○	Rated Capacity Tot./Sens./ Heat.

Piping Legend	
Actual Length	
Liquid / Suction Gas diameters	
Note: It is the responsibility of the consultant or contractor, to verify and confirm that the equipment selection and system design is correct before installation.	

Branches Legend	
a	RBM-BY55E (x14)
b	RBM-BY105E (x3)
c	RBM-BY205E (x1)

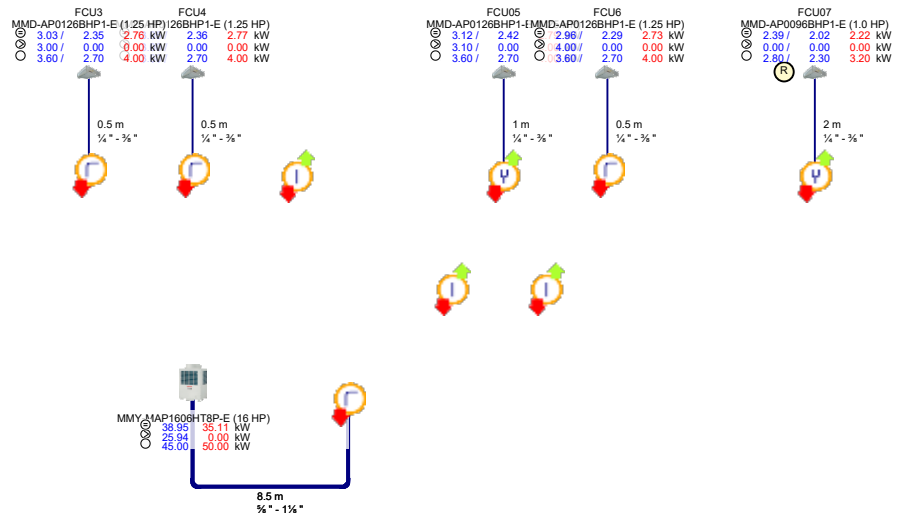

System 1

Floor: 1st

Elevation: 3m above Outdoor Unit

System Information	
Indoor Units	19 of 36
Capacity	125.3%
Total Pipe Length	157.5 m
Indoor Cap. Tot./Sen.	47.44 kW/38.09 kW
Indoor Cap. Heat.	43.88 kW
Building diversity	25%

Outdoor/Indoor Legend	
Model Name (Capacity Code)	
*Room name	
⊖	Corrected Capacity Tot./Sens./ Heat.
⊕	Required Capacity Tot./Sens./ Heat.
○	Rated Capacity Tot./Sens./ Heat.

Piping Legend
 Actual Length
 Liquid / Suction Gas diameters
 Note: It is the responsibility of the consultant or contractor, to verify and confirm that the equipment selection and system design is correct before installation.

Branches Legend	
a	RBM-BY55E (x14)
b	RBM-BY105E (x3)
c	RBM-BY205E (x1)

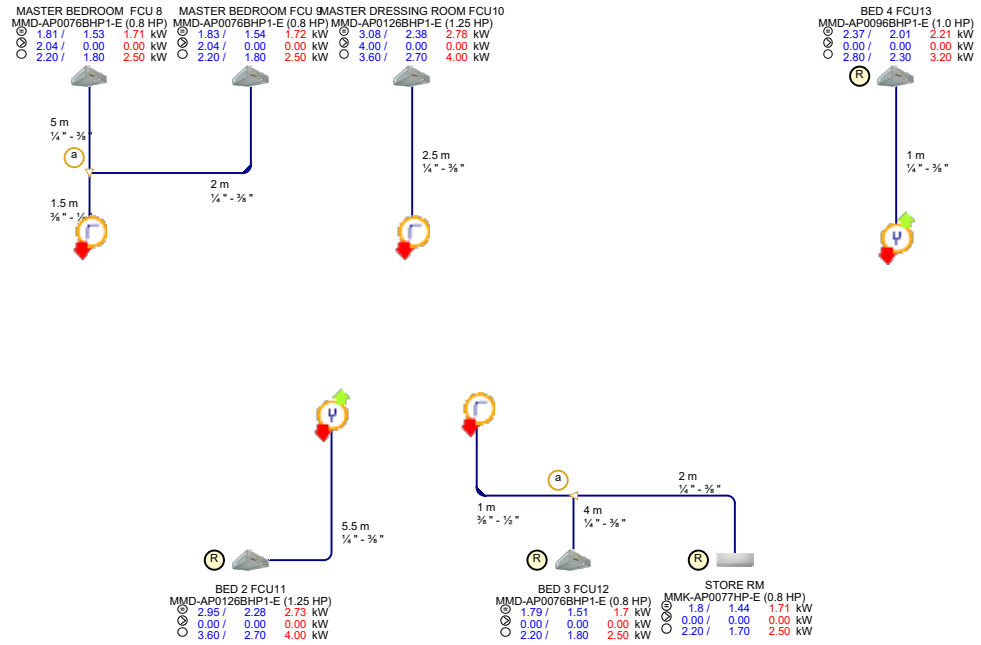

System 1

Floor: 2nd

Elevation: 6m above Outdoor Unit

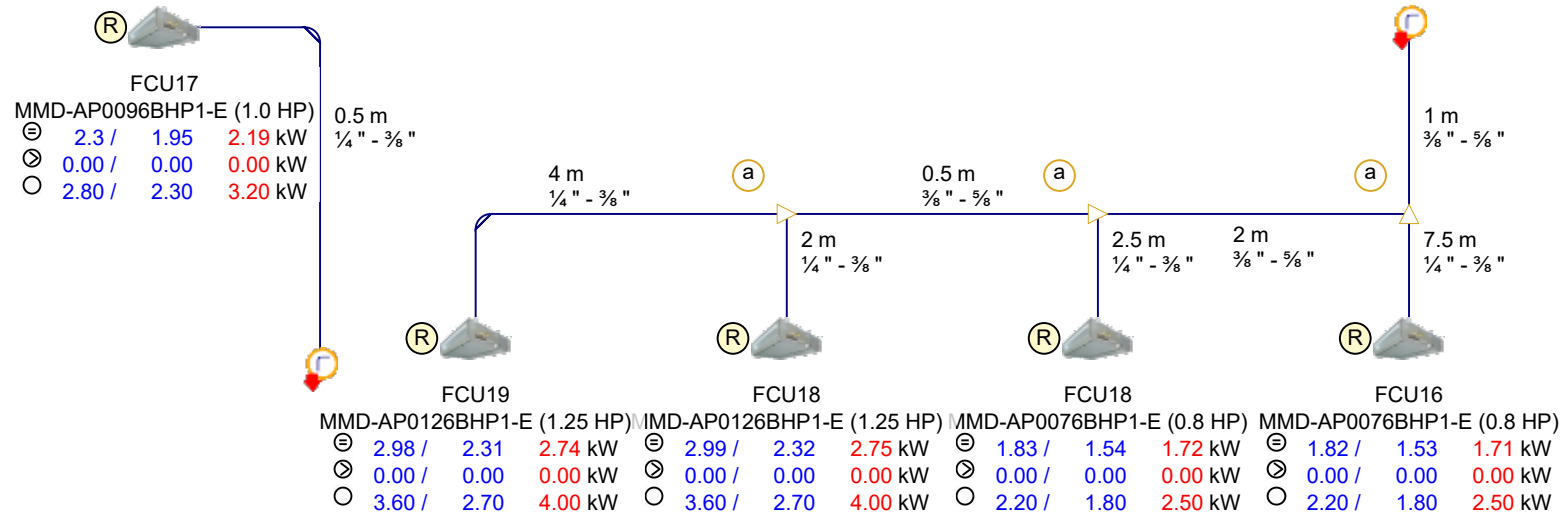

System Information

Indoor Units	19 of 36
Capacity	125.3%
Total Pipe Length	157.5 m
Indoor Cap. Tot./Sen.	47.44 kW/38.09 kW
Indoor Cap. Heat.	43.88 kW
Building diversity	25%

Outdoor/Indoor Legend

Model Name (Capacity Code)	
*Room name	
⊖	Corrected Capacity Tot./Sens./ Heat.
⊗	Required Capacity Tot./Sens./ Heat.
○	Rated Capacity Tot./Sens./ Heat.

Piping Legend

Actual Length
Liquid / Suction Gas diameters
Note: It is the responsibility of the consultant or contractor, to verify and confirm that the equipment selection and system design is correct before installation.

Branches Legend

a	RBM-BY55E	(x14)
b	RBM-BY105E	(x3)
c	RBM-BY205E	(x1)



Toshiba Design AIRS - Floor Perspective

SYMBOL	DESCRIPTION
SWITCH	SWITCH
ROUTER	ROUTER
SERVER	SERVER
CLIENT	CLIENT
...	...

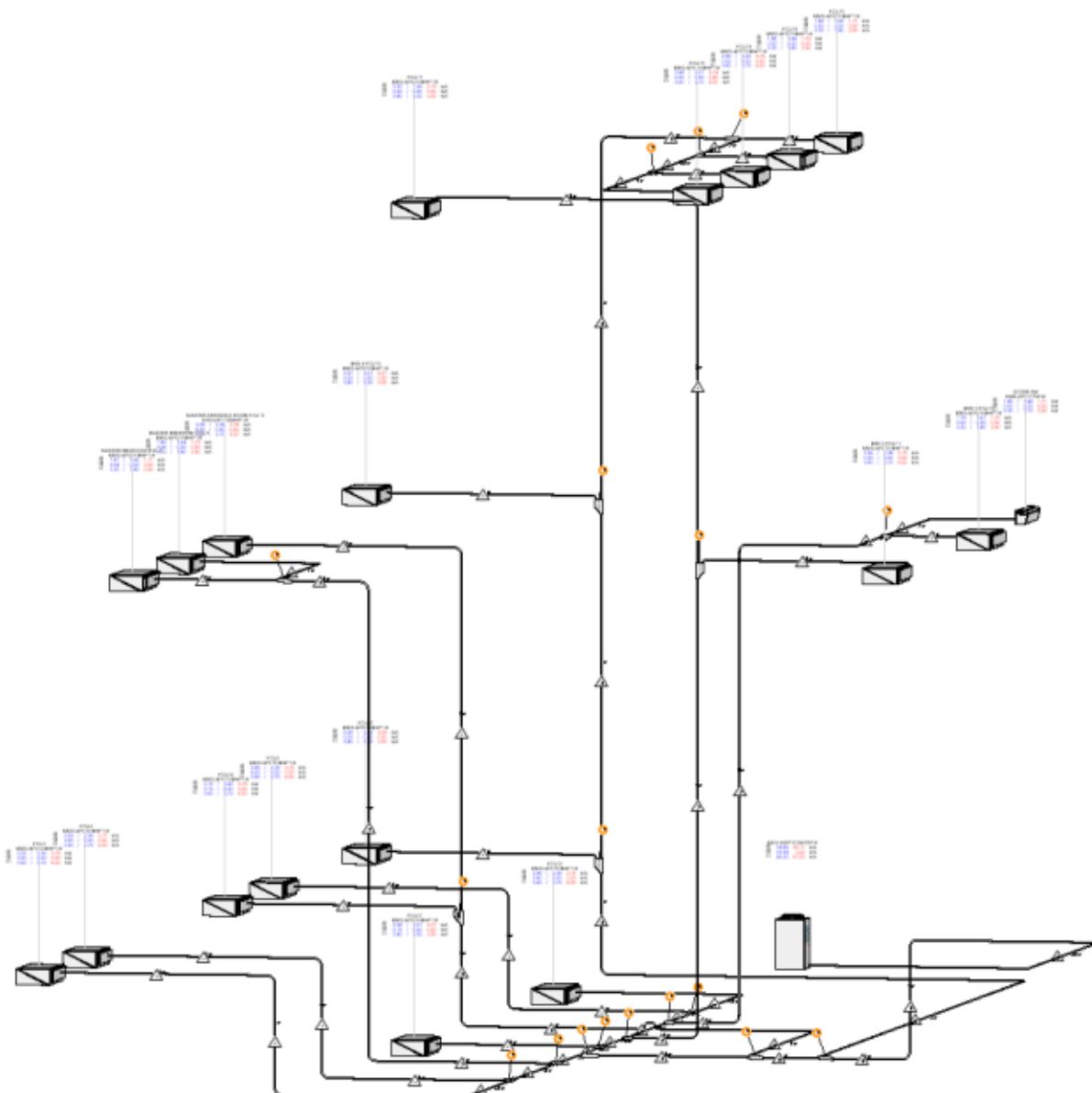

SYMBOL	DESCRIPTION
SWITCH	SWITCH
ROUTER	ROUTER
SERVER	SERVER
CLIENT	CLIENT
...	...

Toshiba Design AIRS - Piping Diagram

System 1

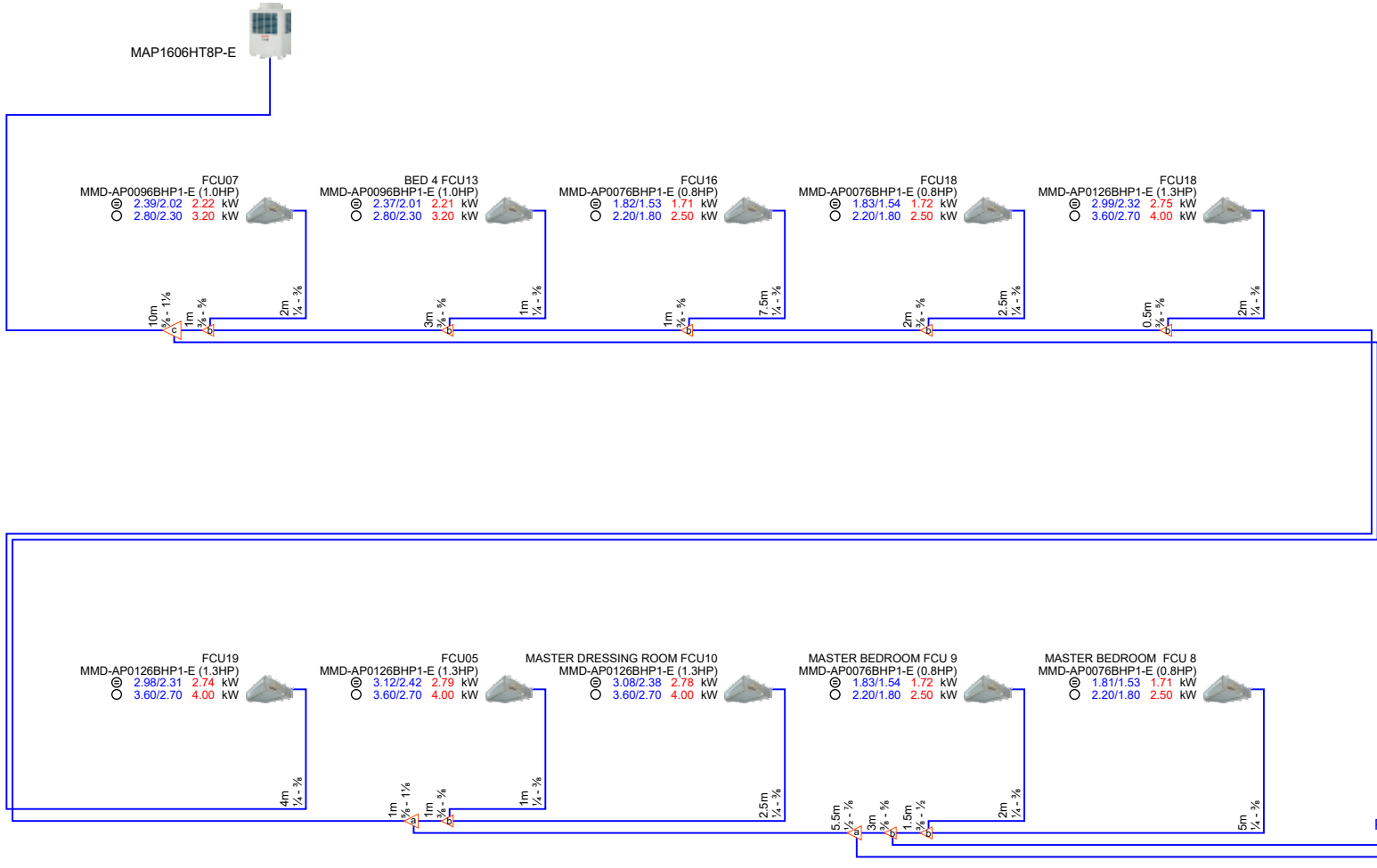

Symbol Legend

Piping*

*Note: Pipe diameters in inches

Branches Legend

RBM-BY105E	a	(x3)
RBM-BY55E	b	(x14)
RBM-BY205E	c	(x1)

Remote Controller Legend

RBC-AS41E	1	(x10)
-----------	---	-------

Toshiba Design AIRS - Piping Diagram

System 1

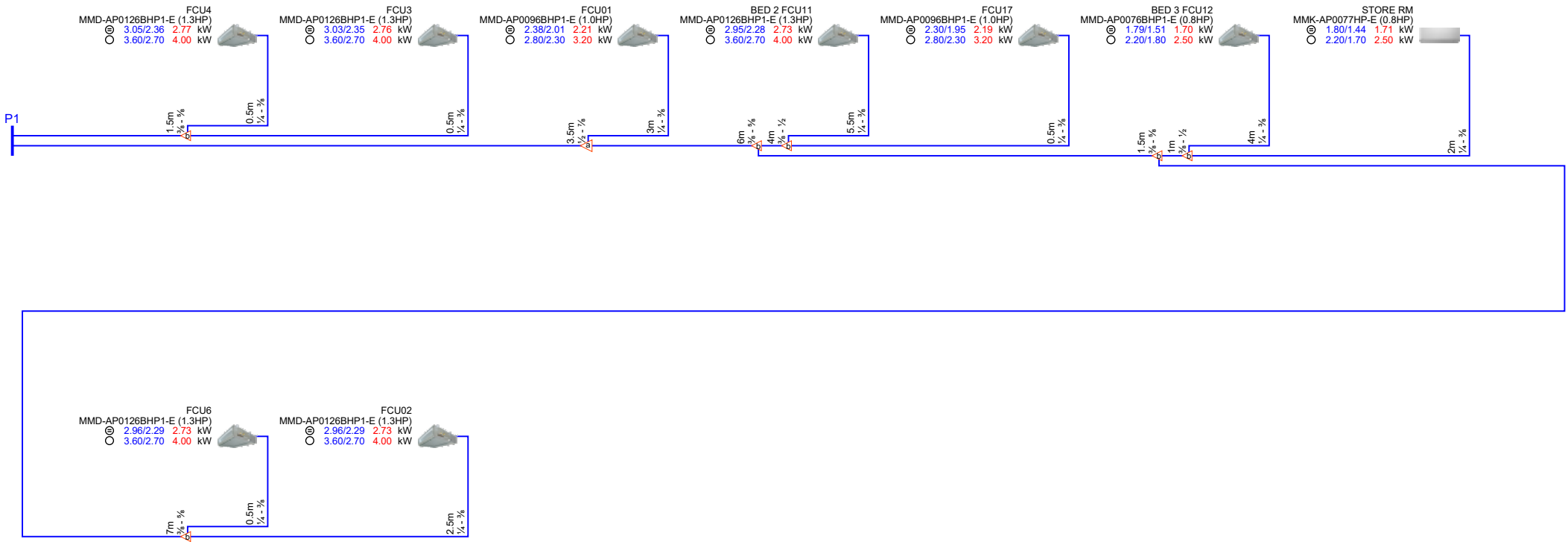

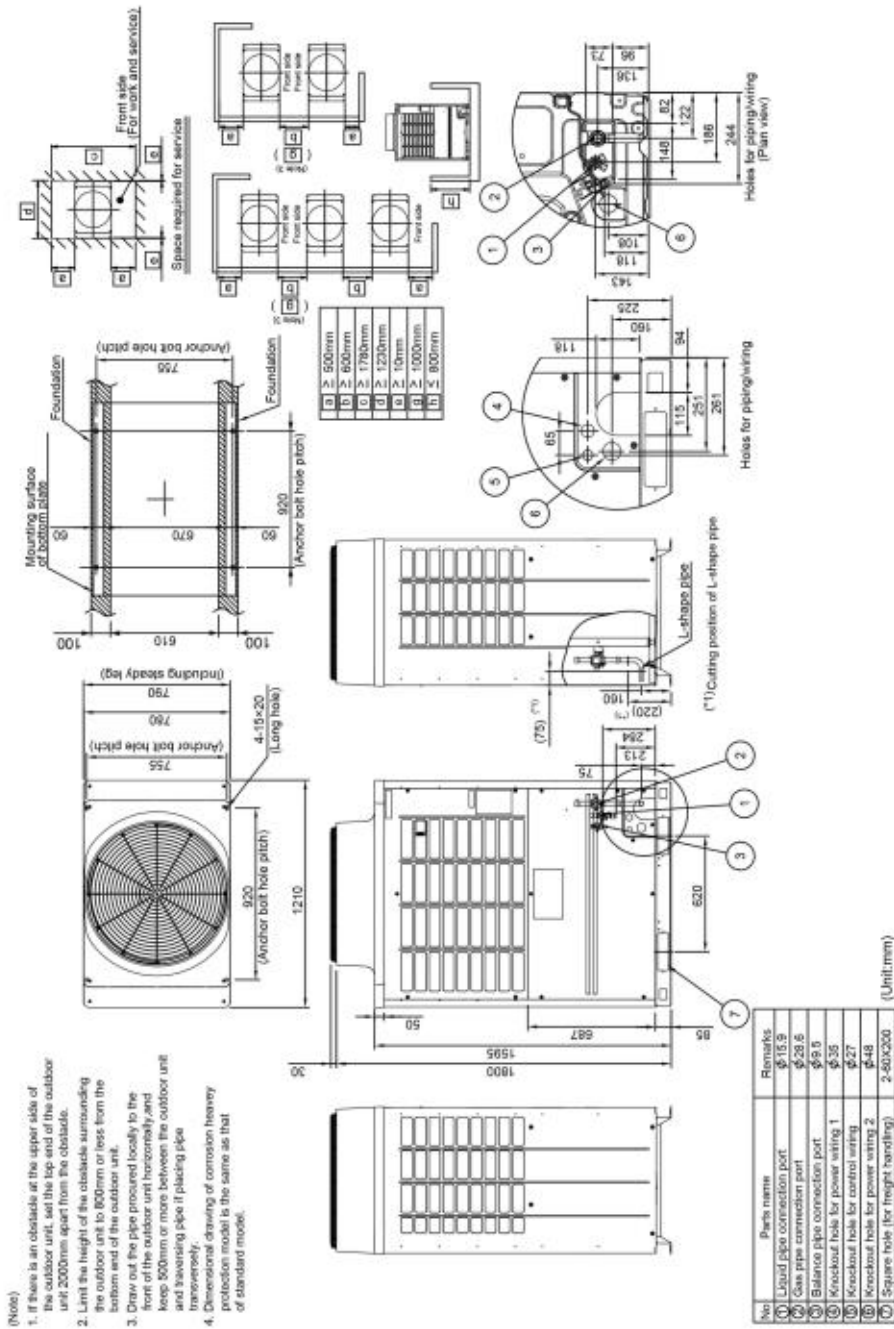

TOSHIBA
Leading Innovation >>>

Customer: **WATKINS**
Project: **KIDDEPORE HALL**
Revision: **REV 5**
Reference: **WATKINS**



Type: **Outdoor Unit**
Model: **MMY-MAP1606HT8P-E**

Date: **17-May-19**
Scale: **none**
Unit: **mm**
Page: **4**

(Unit: mm)

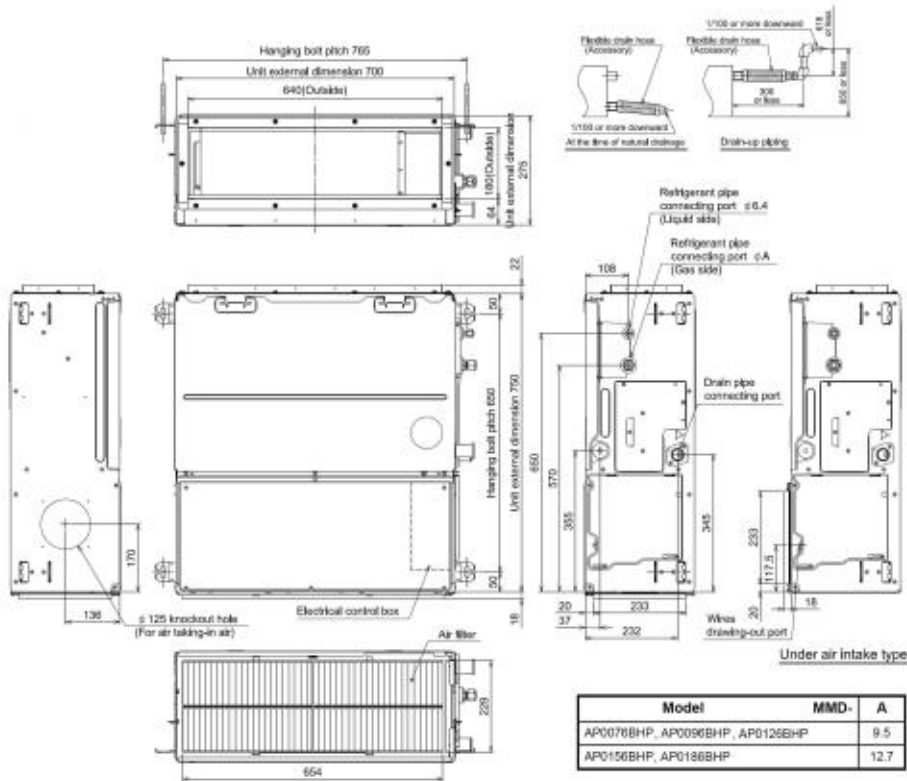

• For duct design

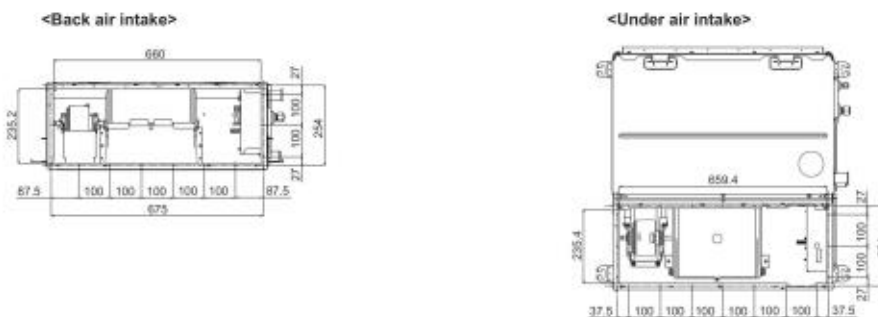

TOSHIBA
Leading Innovation >>>

Customer: **WATKINS**
Project: **KIDDEPORE HALL**
Revision: **REV 5**
Reference: **WATKINS**



Type: **Standard Concealed Duct**
Model: **MMD-AP0076BHP1-E**

Date: **17-May-19**
Scale: **none**
Unit: **mm**
Page:

RBC-AS41E

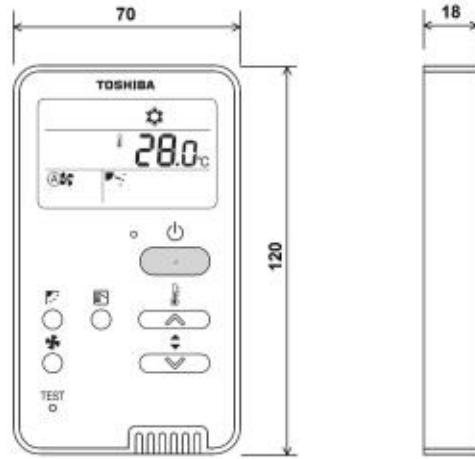

TOSHIBA
Leading Innovation >>>

Customer: WATKINS
Project: KIDDEPORE HALL
Revision: REV 5
Reference: WATKINS



Type:
Model:

Date: 17-May-19
Scale: none
Unit: mm

Outdoor Unit

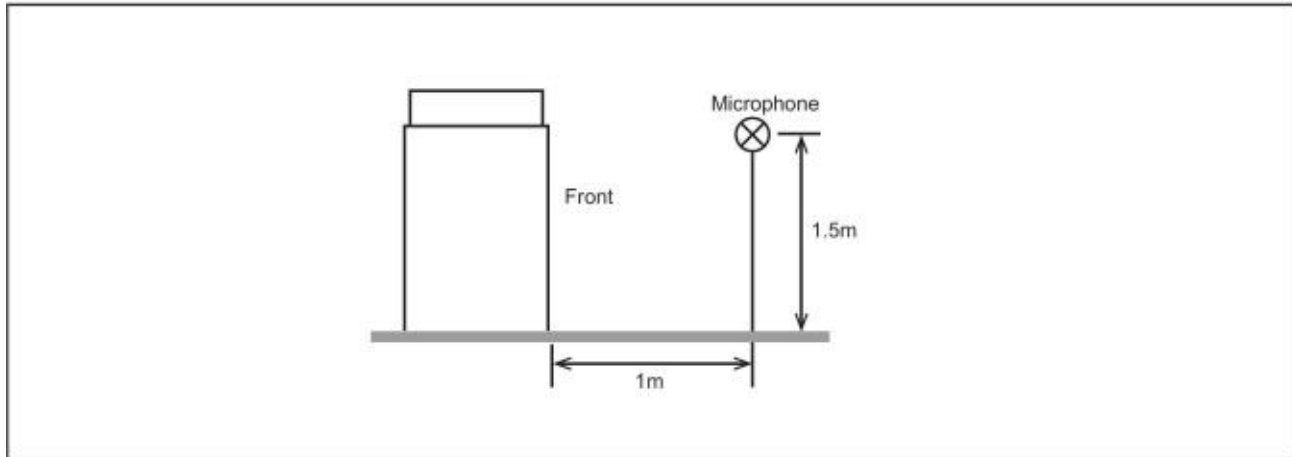

Standard model

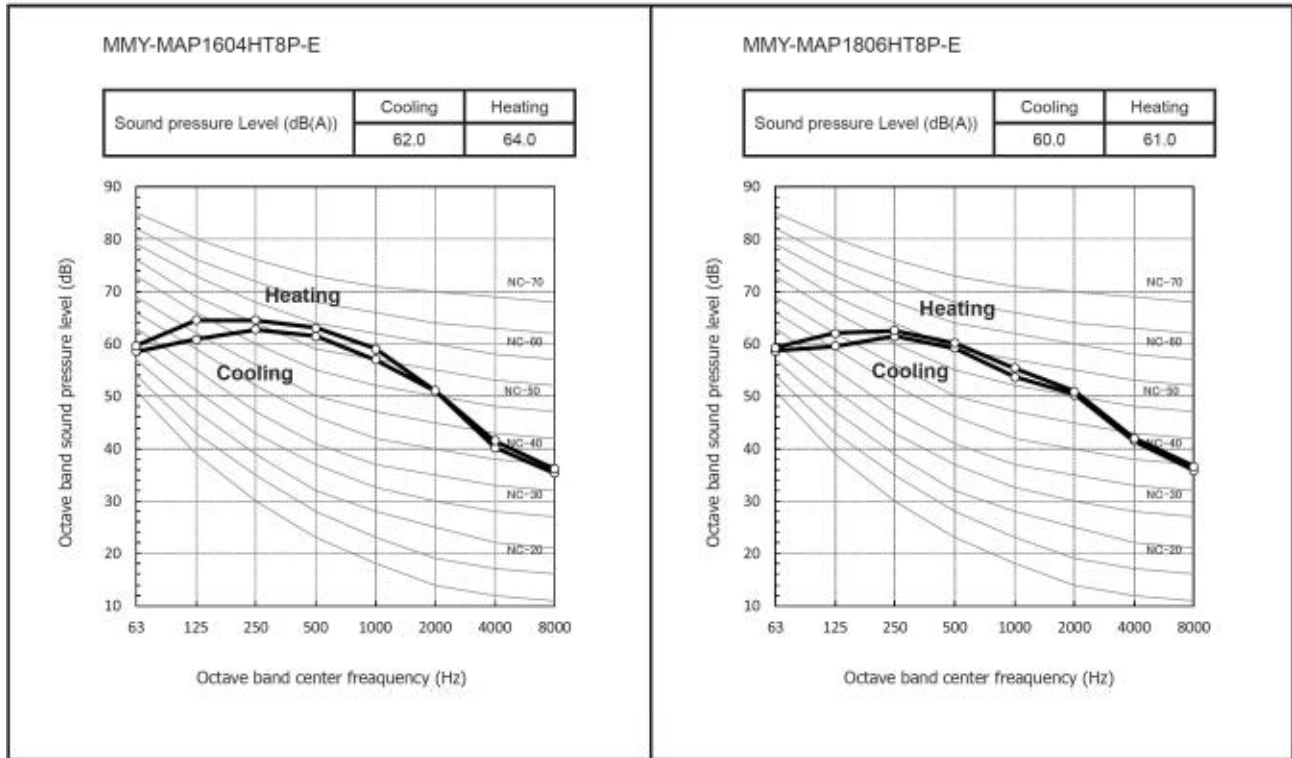

TOSHIBA
Leading Innovation >>>

Customer: **WATKINS**
Project: **KIDDEPORE HALL**
Revision: **REV 5**
Reference: **WATKINS**



Type: **Outdoor Unit**
Model: **MMY-MAP1606HT8P-E**

Date: **17-May-19**
Scale: **none**
Unit: **-**
Page:

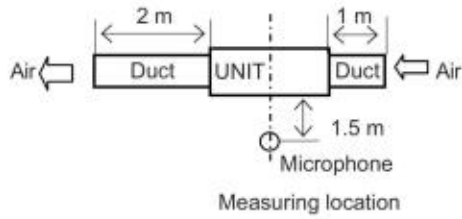

External static pressure 30 Pa

FAN tap	H	M	L
Sound pressure level (dB(A))	29	26	23

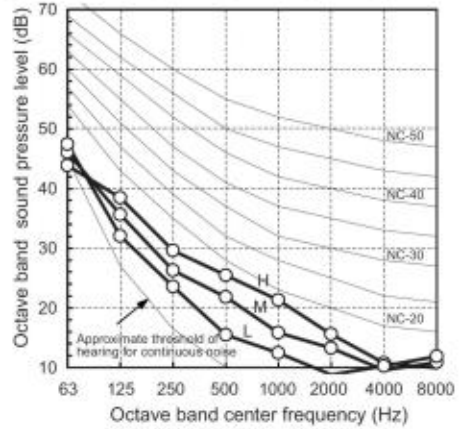

External static pressure 40 Pa

FAN tap	H	M	L
Sound pressure level (dB(A))	31	27	25

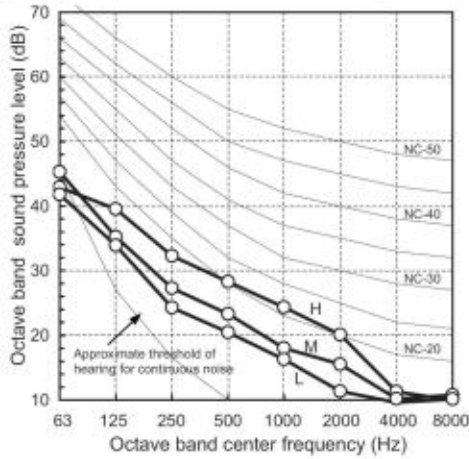

External static pressure 50 Pa

FAN tap	H	M	L
Sound pressure level (dB(A))	32	27	25

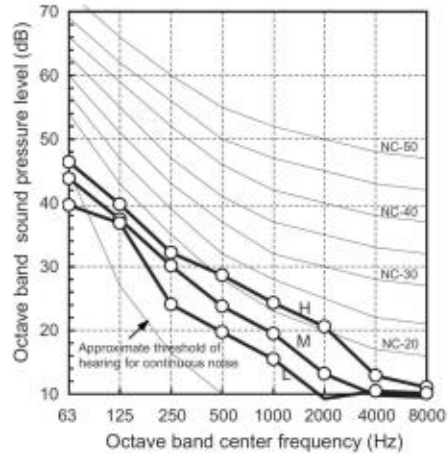

TOSHIBA
Leading Innovation >>>

Customer: **WATKINS**
Project: **KIDDEPORE HALL**
Revision: **REV 5**
Reference: **WATKINS**



Type: **Standard Concealed Duct**
Model: **MMD-AP0076BHP1-E**

Date: **17-May-19**
Scale: **none**
Unit: **-**
Page: **-**

External static pressure 65 Pa

FAN tap	H	M	L
Sound pressure level (dB(A))	33	29	26

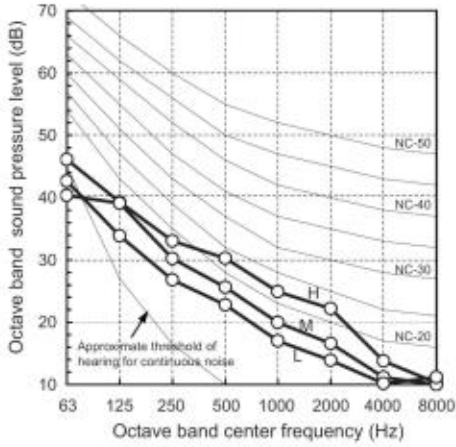

External static pressure 80 Pa

FAN tap	H	M	L
Sound pressure level (dB(A))	33	30	27

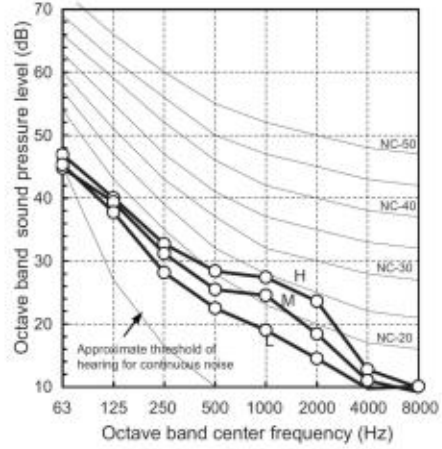

External static pressure 100 Pa

FAN tap	H	M	L
Sound pressure level (dB(A))	36	31	27

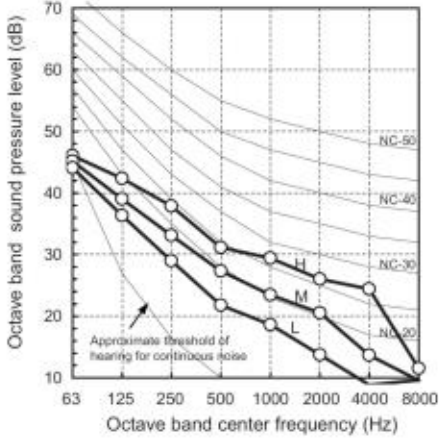

External static pressure 120 Pa

FAN tap	H	M	L
Sound pressure level (dB(A))	37	33	28

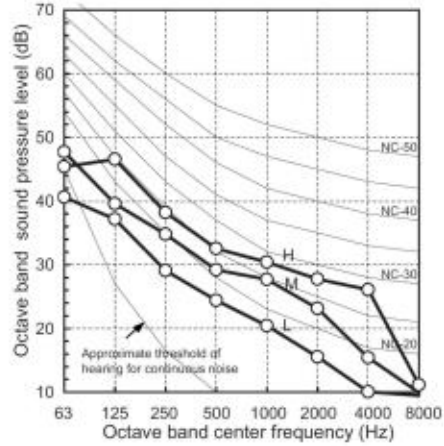

TOSHIBA
Leading Innovation >>>

Customer: **WATKINS**
Project: **KIDDEPORE HALL**
Revision: **REV 5**
Reference: **WATKINS**



Type: **Standard Concealed Duct**
Model: **MMD-AP0076BHP1-E**

Date: **17-May-19**
Scale: **none**
Unit: **-**
Page:

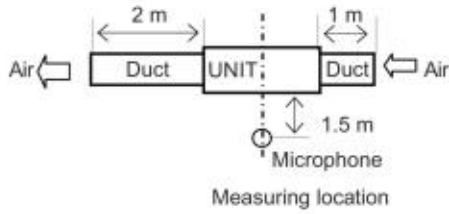

External static pressure 30 Pa

FAN tap	H	M	L
Sound pressure level (dB(A))	30	26	23

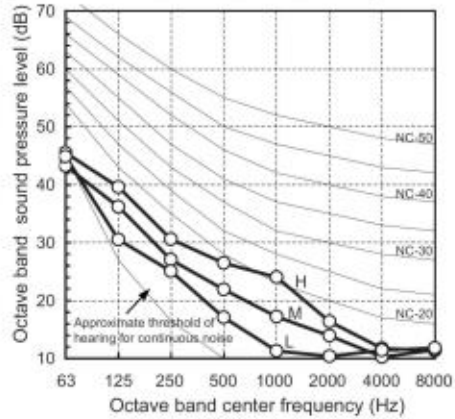

External static pressure 40 Pa

FAN tap	H	M	L
Sound pressure level (dB(A))	31	27	25

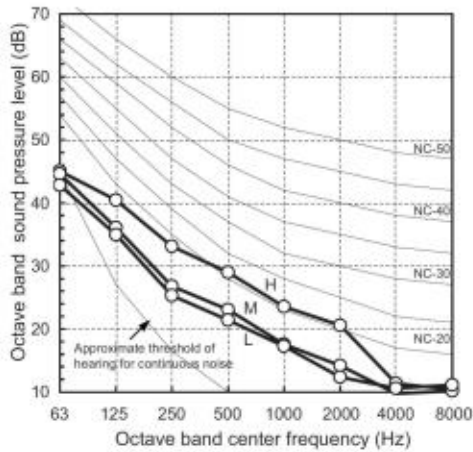

External static pressure 50 Pa

FAN tap	H	M	L
Sound pressure level (dB(A))	32	28	25

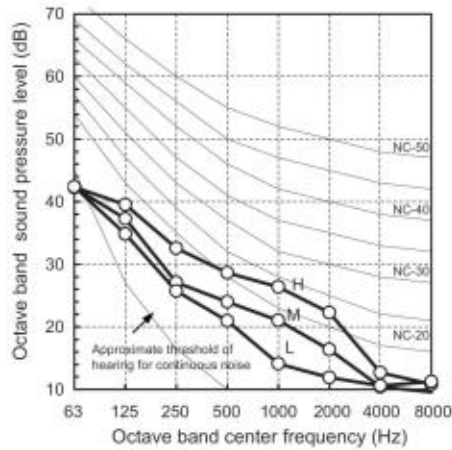

TOSHIBA
Leading Innovation >>>

Customer: **WATKINS**
Project: **KIDDEPORE HALL**
Revision: **REV 5**
Reference: **WATKINS**



Type: **Standard Concealed Duct**
Model: **MMD-AP0096BHP1-E**

Date: **17-May-19**
Scale: **none**
Unit: **-**
Page: **-**

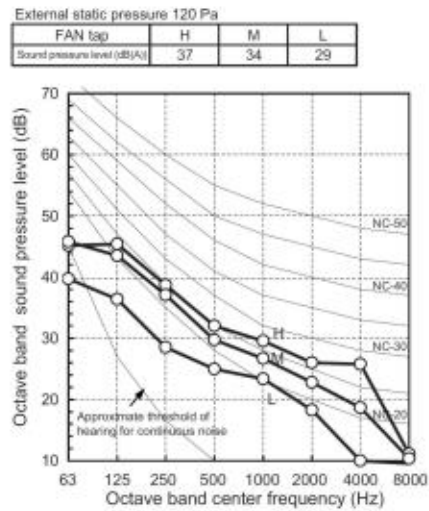
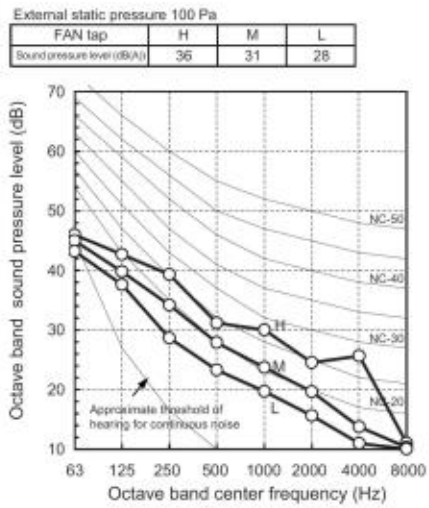
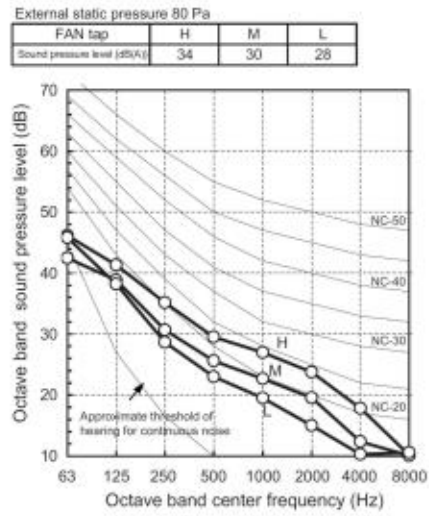
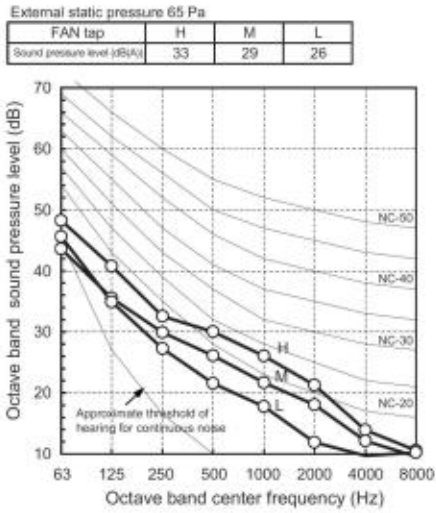

TOSHIBA
Leading Innovation >>>

Customer:
Project:
Revision:
Reference:

WATKINS
KIDDEPORE HALL
REV 5
WATKINS



Type: **Standard Concealed Duct**
Model: **MMD-AP0096BHP1-E**

Date: **17-May-19**
Scale: **none**
Unit: **-**
Page: