

Image 1 - Massing model view to front elevation as proposed

design and access statement

**Change of use of rear ground floor car park to offices B1(a)
 with alterations to the front and rear ground floor elevations**

LF Canlife UK Property ACS C/O Canada Life European Real Estate
 74A Charlotte Street, London, W1T 4QJ

Image 2 - massing model view to rear elevation as proposed

Contents

- 1.0 Introduction
- 2.0 The client and the brief
- 3.0 The existing site
- 4.0 The proposed site
- 5.0 The building proposals
- 6.0 The design aesthetic
- 7.0 External area features
- 8.0 Access and security
- 9.0 Process and programme
- 10.0 Sustainability
- 10.1 energy use and production
- 10.2 sustainable development principles
- 11.0 Conclusion



1.0 Introduction

This design and access statement (DAS) is produced for and on behalf of the applicant, to be read in conjunction with proposal plans for the ground floor, Ariel House, 74A Charlotte Street, London, and specifically the proposal to convert existing car park and yard areas to provide additional office accommodation, and associated changes to elevations.

This report sets out the design and development intent of the applicant and includes information on the site, the client, the projected programme and proposed works and development and demonstrates the various important features of the development proposals, both in terms of design and in terms of building and site use.

2.0 The applicant and the brief

The applicant commissioned Burogloo and the wider project team to look into creating a more sustainable and suitable use for central London car parking space that is not in use. The applicant has owned and managed the site for many years and, over those years, has invested heavily in the refurbishment, repair and maintenance of the application building. The applicant has a long-term plan for Ariel House, with this proposed development central to that plan.

The application is part of an ongoing process of improving the building and bringing about modernisations suited to its position, use and location and to meet growing demand for good quality office space. The site's central London location and excellent transport links, and the drive through legislation to reduce traffic and specifically personal vehicle use in central London, has resulted in the car parking areas forming the main area of the application being underused and unpopular with building users.

The brief therefore involves (1) the creation of usable office space, connected to that that exists at ground floor level, (2) refreshing and improving the rear elevation to Charlotte Mews and (3) refreshing and updating the front elevation at ground floor level, including replacement, modernised barrier / balustrade between public space on Charlotte Street and the site. The brief included for highly considered access and amenity from both Charlotte Street and Charlotte Mews as part of the redesign of elevations.

The applicant also requested the incorporation of cycle storage for the new space, covered and secured. This is provided whilst maintaining substation access.

Overall the development is designed to maximise usable space, create new office accommodation and integrate this new space into the ground floor elevation / street façade.

There are minor internal alterations required to meet the applicants overall brief, but these are not the subject to this application.

Part of the brief is the programme to completion ready for occupation, set for fourth quarter of 2020, which clearly shows the commitment the applicant has made and will continue to make to the building and local area in providing good quality office accommodation and positively impacting on both the Charlotte Street and Mews frontage.

3.0 The existing site and building



Image 3 - Aerial view of the application site

The existing site is an 8-storey office building in single ownership. It has been subject to refurbishment and improvement over many years. The building was originally two separate buildings conjoined and updated through to the early 1980's, including for its three-storey section to the rear elevation (to Mews) and including for its striking decorative stone cladding to front elevation (to Charlotte Street).

In recent times the front elevation has been updated, minor amendments to increase glazing have been carried out to the rear and, most recently, a modern cladding system was added to the 6th floor recessed façade facing out onto a small decked area. The glazed balustrade at this upper level was also replaced with a more modern, cleaner alternative solution. whilst this later intervention is at high level and, in many respects, only viewed obliquely, it is an improvement akin to those now proposed at ground floor level.

Most recently the applicant has been looking at the possibilities of improving the look of, approach to and overall quality of the facades and immediately located spaces. Additionally, the car parking to the rear has been the subject of feasibility studies to better utilise the space and improve the buildings outlook onto Charlotte mews.

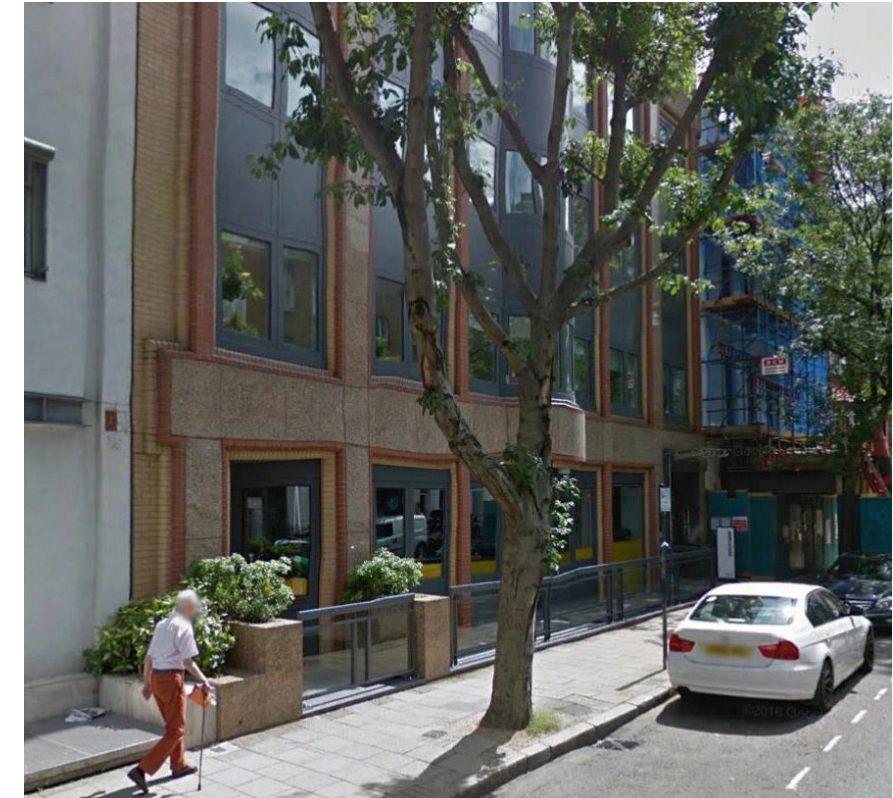

Image 4 - Street view to building from Charlotte Street

The building faces onto and is accessed from Charlotte Street, its principal elevation. The building is set back from the street affording an infill development at lower ground floor which in turn creates a decked, enclosed street 'buffer', across which the entrance to the building crosses to the South-Western corner.

To the rear are two entrance / exit points which primarily serve as rear exit doors to access the car park / yard and the Mews, but with primary function being fire escape routes that serve all floors of the building. These doors form secondary access to the building from the Mews.

The yard / car park area is accessed from the Mews and is gated and enclosed. The gates open out directly to the Mews. There are double doors currently providing access from the ground floor offices (extant) to the car park area.



Image 5 – view to rear of building from Charlotte Mews

The building forms part of a complete frontage to both Charlotte Street and Charlotte Mews so that it is only the front and rear elevations that are visible except obliquely and at high level. Both street frontages are very mixed in terms of build period, architectural style, height and massing.

The building is mainly of brick and blockwork external construction with steel cladding-supporting frame system, to both front and rear elevations.

The ground floor front elevation is brick-clad concrete framed construction with infill fascia sections of decorative stone cladding, with 'curtain walling' style aluminium and glazed panelling both at ground floor level and above.

The ground floor to second floor rear is a brick-clad concrete frame (with portalised steel frame roof system over second floor) with aluminium infill framed 'curtain walling' solid spandrel and glazed panels to rear.

The building is in a good state of repair given the various construction periods in which it has been built, amended and extended. Furthermore, the applicant has undertaken extensive repair and refurbishment over a prolonged period, a period which this application looks to extend.

The building is served by gas, electricity, mains water and mains (combined) drainage and communications connectivity.

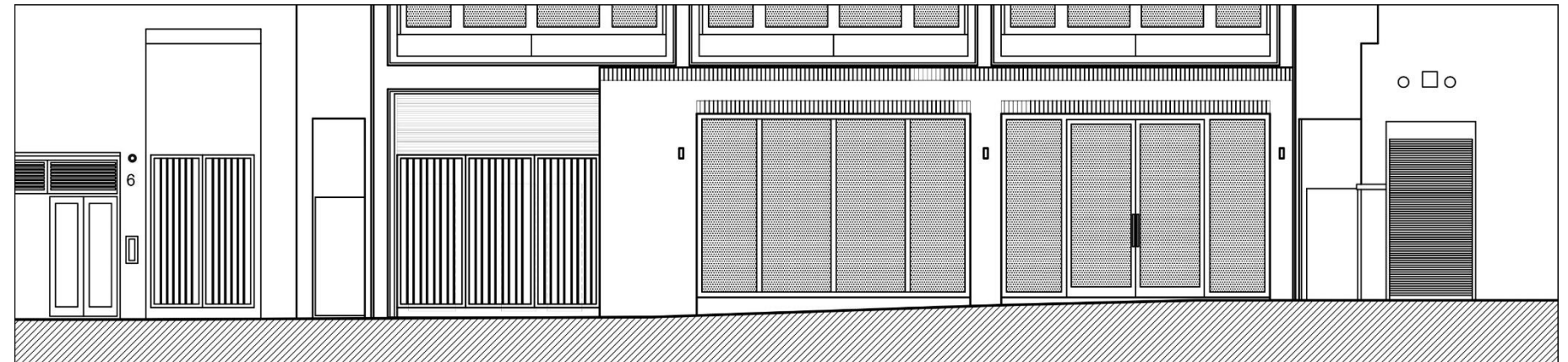

Image 6 – part elevation to Charlotte mews as proposed

The site is set in a wider mixed-use central London urban area, and is widely connected to other central London areas both on foot and via public and private transport.

The local area is subject widespread development and improvement, including significant development immediately to the North providing a mix of accommodation, architectural styles, massing and detailing.

4.0 The proposed site

The proposal involves the careful removal of all ground floor front architectural fascia elements, including the raised planters and the curtain walling / glazing to the front elevation, and including the main entrance doors.



Image 7 – part elevation to Charlotte Street as proposed

The proposals also include amendments the ground floor front 'buffer' zone between street and building façade and the removal and disposal of, and replacement of, the front railings and upstand railing supports.

The proposal to the rear involves the wholesale removal of gates and boundary treatment, including some localised brick cladding to structural frame. It involves the removal of the car park / yard area finishes and reducing of this level to afford localised level access for the Mew office accommodation being created and the substation to the left-hand side as viewed from the Mews.

Both elevations will be subject to other minor amendments, as set out in drawn information, to accommodate the proposals.

Only localised works of repair and stitching-in are proposed to the street edge on both Charlotte Street and Charlotte Mews with the new proposal connecting into the street scenes based upon localised existing levels and treatments / finishes. This is as set out on the various design drawings and documents provided.

Wherever possible materials removed will be separated and recycled, or

sustainably disposed of. The applicant is proud of their sustainable approach to development and will undertake to utilise all materials resulting from demolition and material amendment works wherever practicable.

Ground levels will be reduced in some areas to accommodate foundations for the new rear elevation construction to office accommodation.

The site is to be enclosed on all sides, with the western edge bounded by Charlotte Street and eastern by Charlotte Mews. Elsewhere the building is flanked by other buildings of similar bulk and height.

The building occupies the site almost completely, aside of external but enclosed ground floor front 'buffer' area over lower ground floor office accommodation.



Image 8 – typical example slender aluminium Curtain Walling system

The site, and building, for the purposes of this application can be seen to be split into 2.

The front part of this application deals with access from Charlotte Street into the extant ground floor office accommodation (front) and changes and improvements to the front elevation at ground floor level and at the street edge.

The rear part of this application deals with a new section of office accommodation (connected to the ground floor front area) and access from Charlotte Mews. This work involves the overhauling of the rear elevation at ground floor level and associated improvements, including cycle storage and level access.

Throughout the two areas, and assisted by the local topography, levels have been kept relatively flat to aid general accessibility. Materials are mixed, as set out on the documentation issued as part of the planning application and chosen generally to compliment the extant building and neighbours finishes and treatments.

5.0 The building proposals

The building proposals are limited to:

- Creation of additional office space (Charlotte Mews)
- Access to extant office accommodation front
- Access to proposed office accommodation rear
- Changes to front elevation including balustrade railings at street boundary, and including front entrance treatment and associated signage
- Changes to the rear elevation to afford proposed office accommodation, access and elevational treatment to suit development
- Cycle storage
- Substation access

The office accommodation proposal will create:

- Additional nett internal office area of 121sqm
- Cycle storage enclosure of 10.7sqm

The front elevation amendments will not provide only negligible additional nett or gross internal area.

6.0 Design Aesthetic

The approach to the front elevation is to reduce the 'clumsiness' of the rather dated ground floor glazing, balustrade and entrance feature and replace with thinner section glazing infills, and tidier and less obtrusive glazed balustrades. Through linked use of materials, the design looks to ensure the entrance to the building (reception entrance as existing) is an integral part of the buildings streetscene at ground level.

Due to the buildings front elevation cladding system continuing from ground floor up to fifth floor, there are limitations on the design input to the façade as a whole, and the relatively light touch approach is designed to ensure that the ground floor becomes more appealing whilst not detaching the design aesthetic from upper floors. As such the brick cladding is retained and utilised, with thin-frame glazing systems and raised internal ceiling levels and dropped cills to ensure clean lines and striking full height glazing to office and reception areas.

The ground floor is given some unity, too, through use of full height glazing and matching glazing sections throughout, standing alone from the upper storey glazing treatment, whilst at the same time linking the office glazing with reception adjacent.

To the street edge acid-etched glazed balustrades will replace the metal and glazed ones, with a refreshed aluminium-clad steel glass support system, simplifying the overall look to the street edge, whilst maintaining separation. This language is used to create an enclosed entrance to the existing office accommodation to the North of front elevation, and to the south the architectural / material language is used to 'link' the existing ground floor (reception) entrance to the front façade.

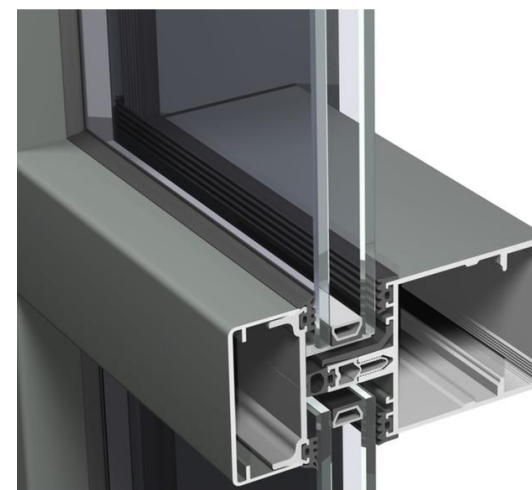

Image 9 – typical example slender aluminium Curtain Walling system

This is reinforced by the use of the aluminium low-level cladding to the balustrade wrapping up and around the entrance door. An acid-etched glazed entrance canopy is proposed, again using the material language to unite the front entrance ground floor elements.



Image 10 – brick soldier course example

To the rear, the form is dictated to a great degree by the space proposals, whereby the street elevation at ground floor is partially set within the existing brick-clad structural frame and partly pushes through this to the street (Mews) elevation / boundary.

Light is maximised through, again, thin-section colour-coated metal-framed full height fenestration, including large entrance doors. The colouring of the fenestration is taken from the glazed aluminium spandrel and frame detail at first and second floor over.



Image 11 – typical traditional buff multi brick Proposed for rear elevation infill architecture

Elsewhere to the rear multi batch buff bricks, in both stretcher and stack / soldier bonding is utilised to help the 'extension' best sit in with the red and buff brick cladded elevation features that exist, and the buff brickwork lends itself to being situated alongside the recent mixed-use development

adjacent (No 6 Charlotte Mews), itself extensively detailed in multi-batch buff brickwork detailing.

The proposed development also includes a small cycle / service yard, itself enclosed using simple black railings akin to those used adjacent.

Image 12 – photoshop image of Charlotte Mews proposals



modernising these features.

Fittings and fixtures will be an integral part of the overall external finishes' aesthetic and as such external lighting, cameras, vents and louvre positions and other fittings and fixtures are generally indicated. These will be industry-leading fittings and fixtures colour-matched to the elevations / fenestration, wherever



Image 14 – typical external light

they occur. Internally, the building will be functional, efficient, light, bright and spacious. Ceiling heights will be maximised, maximising light penetration.

Amendments to link the existing space and proposed space will give visual connectivity between the Street and the Mews areas.

Within the cycle and services yard area the elevation is set significantly back from the pavement line, and this elevation is predominantly made up of louvred cladding and louvred service access doors, colour-matched to the fenestration. Whilst obscured from view by the yard enclosure and due to being set back from elevation, the architectural treatment deliberately links this space to the rest of the building. The aesthetic approach in both front and rear instances is to make improvements in a way so as to add to the quality of the street scape, respecting the existing larger view to the upper storeys, whilst utilising better and more stylish materials and productions.

Aesthetically, the applicant wanted to 'nod' towards the vernacular of

the area, whilst providing a strong architectural language that would not look out of place but would speak to the applicant's perception of the value of the site as a valuable asset to the area.

The entrance treatment and rear elevation brick and glazing treatments are designed to add interest and to subtly enhance the streetscape without



wholesale architectural changes to the upper storeys. Particular attention has been paid to street edge treatment and



Image 15 – massing model shot to rear office space

7.0 External area features

The external areas to the site are:

1. The buffer zone between Charlotte Street and the front elevation / façade of the building. The buffer zone caps the office accommodation in lower ground floor areas below and in enclosed via the proposed replacement glazed balustrades.

2. The enclosed cycle / services yard created behind black railing and gates mimicking those to the development adjacent and following the street (Mews) boundary of the property

To the front, existing matching decking materials will be utilised, extending and amending what already exists.

To the rear the pavement finishes will be extended into the enclosed yard area. Within yard area cycle storage will be provided.

8.0 Access and Security

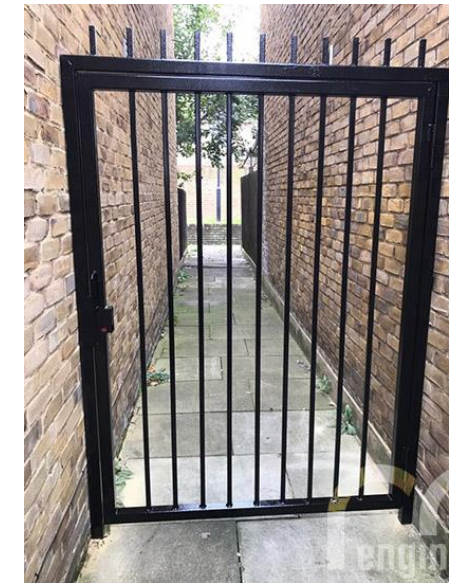

Image 16 – typical metal railing / gate as proposed

Due to the nature of the site and its location, security is a consideration first and foremost and this is clearly defined by the design aesthetic of external areas and the building fabric as set out.

Due to the fact that the proposal is for new office accommodation and access to existing, and specifically to the rear a new floor level is being created linked to the Mews level adjacent, level access is afforded to all areas for all staff and visitors.

Within the building level access is afforded to all areas via a new lift.

Access gates to yard are electrically controlled and opened.

Access has been at the heart of the design brief, ensuring the entirety of Ariel House is accessible to visitors and staff alike.

9.0 Process and programme

The applicant's commitment to the scheme, the site and the development of a first-class office space, is expressed in the high-quality design, the dedicated team approach and the commitment to a programme that is considered but also ambitious. It is reliant upon a constructive planning and design process and as such a great deal of work has gone in ahead of the planning application, in terms of feasibility and buildability.

The applicant has invested in a process of 'amend, update and renew' strategy, which is critical to the successful regeneration of the underused and aged section of site / building to rear and the significant improvements in the outlook of the building to Charlotte Street, an area that continuously modernises and improves.

10.0 Sustainability

10.1 energy use and production

The servicing of the proposed new internal areas is multi-faceted, providing tailored cooling and heating to various areas. Minimising energy usage is achieved through a holistic design ethos of using building fabric, material specification, space design and servicing solutions to create spaces that, once temperate, require minimal ongoing energy use to provide comfortable accommodation to visitors and staff. Each solution employed will be suited to the individual space requirements and designed as a whole to minimise energy demand, with an eye on ongoing operational efficiency, including systems maintenance and longevity.

External envelope insulation is proposed to significantly outperform the standards set out in the building regulations, and is paired with efficient heating and cooling installations.

As with all new building the proposed MEP services designs are being developed to optimise operational performance, and to keep the energy demand as a whole down, reducing energy use and operational costs, as well as reducing impacting on incoming utilities supplies.

Heat recovery is proposed for the air handling system, which will minimise heat loss and reduce energy use within the building. Heat recovery heat pumps are proposed in the heating and cooling proposed to the office spaces to maximise efficiency, whilst maintaining comfortable working conditions at all times.

All lighting proposed is LED type, with presence/absence detectors for operation and daylight dimming sensors in office accommodation.

In all areas of the design, both fabric and plant, longevity of the system is a key factor in the design development, with close attention paid to ongoing operational efficiency, future maintenance and the longevity of equipment and systems.

All mechanical and electrical and drainage equipment being proposed for the project will be highly efficient, with the latest technologies being used wherever appropriate. Our ambition is for all applicable plant equipment to be certified compliant with the Energy Technology List, further demonstrating the applicant's commitment to creating a building that is highly energy efficient, sustainable and designed with a long lifespan in mind. That commitment extends to improvements to the site itself, providing a positive contribution to building and looking to have a positive impact on the existing infrastructure.

10.2 sustainable development principles

Part of the process from inception of the project to completion of the development is a commitment to sustainable development through careful consideration of materials and processes, for their longevity and sustainable life-time value.

On top of the design specification set out elsewhere, in terms of quality of materials and products to decrease waste, to decrease energy use through

operational phase of the building's life, to decrease maintenance requirements in the future, and to increase efficiency wherever possible, the applicant is committed to the construction phase being an integral part of the sustainable development plan.

Measures that will be implemented include:

- Specifically calling on local suppliers and tradespeople
- Use of certified timber products
- Water use minimisation and reuse
- Waste management and recycling targeting
- Re-use on on-site materials prior to consideration for removal
- Conservation of built forms where applicable, minimise waste
- Careful removal and disposal of hazardous materials
- Use of low embodied-carbon products and materials
- Energy use monitoring and reporting
- Efficient site management to reduce impact on local infrastructure

11.0 Conclusion

Through upgrading and careful replacement of building features, and the development of a highly energy efficient development, the applicant will create a development that will enhance the building within which the development proposals sit.

The applicant's specific requirements and detailed brief demand that the architectural proposals are designed to meet their exacting standards. As such the built form is engineered to be accessible, sustainable, attractive and secure. Their long-term plans for the building demand that the design be sustainable, and that energy use be reduced to a minimum. The outcome of such a brief is a large investment into the building and area, a high-quality development, built to the highest standards to reduce the impact on neighbouring infrastructure, properties and businesses.

The overall development ethos is one of looking to the longer-term and creating additional space and making changes to the existing fabric and access that are suitable for the building, site and setting.

This report, when read in the context of the proposal drawings and supporting planning policy and report documentation, demonstrates the applicant's commitment to providing an accessible, well-designed development for long-term use.

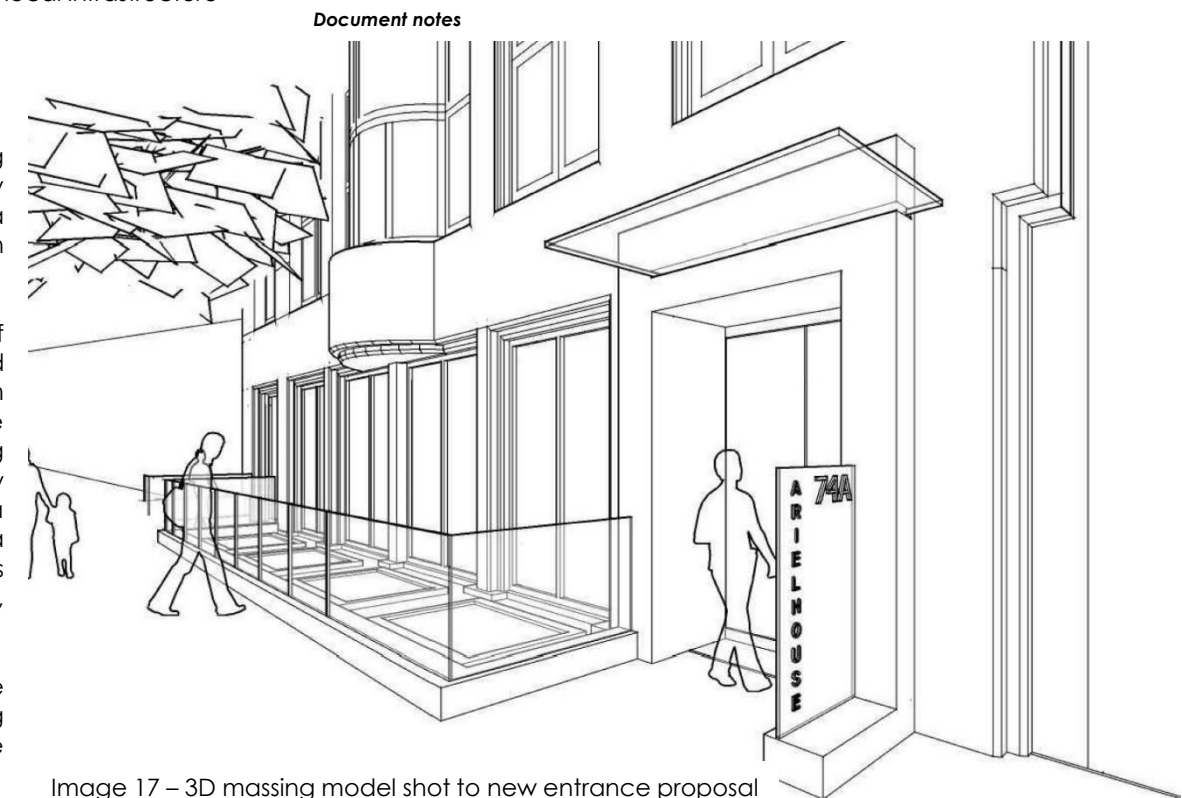

Image 17 – 3D massing model shot to new entrance proposal

Images have been used to demonstrate the design concepts, the material concepts and precedents to the scheme. where used, Google map and street view are used to demonstrate the location and view from highways. All images are used as indicators only. Comparable 3D massing model images are indicative. Design proposals will always be subject to detailed design development and site investigations, surveys and studies, and this study sets out the applicant's intent and proposals, inasmuch as they can be expressed at this design stage. This DAS is compiled in line with CABE guidelines, where appropriate to the proposals.