



The **LGH-RVX-E** is designed to supply fresh air into any commercial building whilst simultaneously extracting stale air. The Lossnay units also recover valuable heat energy for maximum efficiency, with total heat exchange.

Key Features

- Clean, fresh air
- Energy efficient heat recovery
- Can be used in conjunction with Mr Slim and City Multi for highly efficient and effective operation



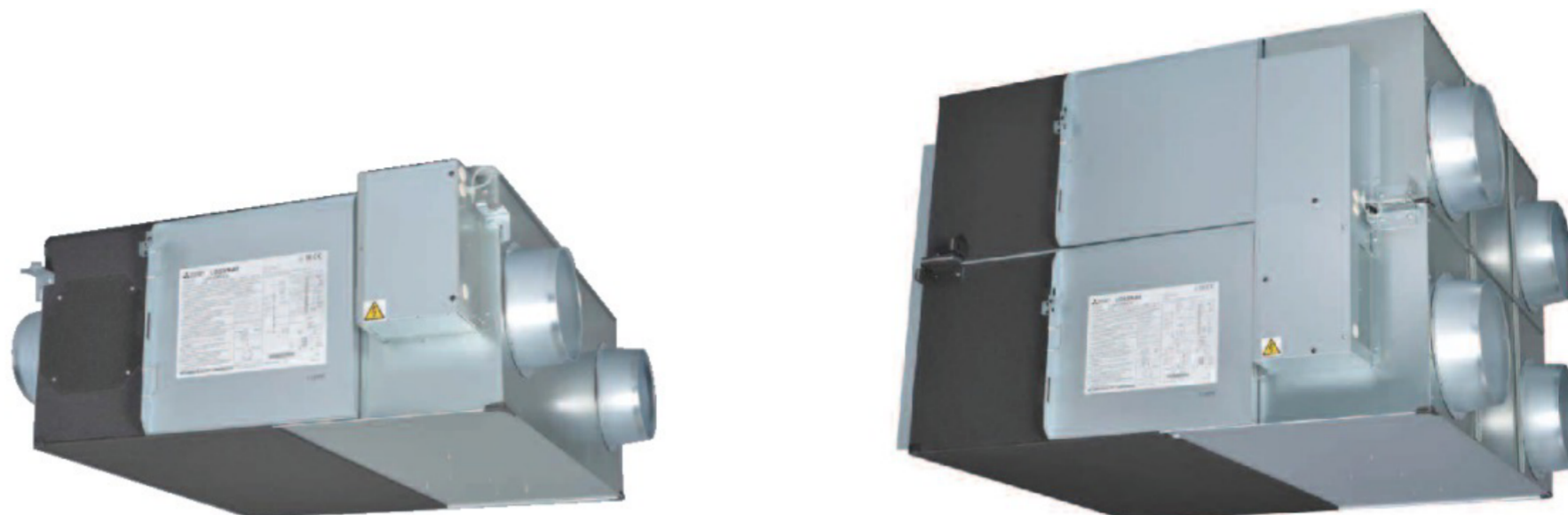

COMMERCIAL MODELS		LGH15RVX-E	LGH25RVX-E	LGH35RVX-E	LGH50RVX-E	LGH65RVX-E	LGH80RVX-E	LGH100RVX-E	LGH150RVX-E	LGH200RVX-E	
ELECTRICAL POWER SUPPLY		220-240V, 50Hz	220-240V, 50Hz	220-240V, 50Hz	220-240V, 50Hz	220-240V, 50Hz	220-240V, 50Hz	220-240V, 50Hz	220-240V, 50Hz	220-240V, 50Hz	
RUNNING CURRENT (A)	SP1	0.10	0.10	0.12	0.13	0.15	0.15	0.17	0.29	0.33	
	SP2	0.15	0.16	0.26	0.26	0.39	0.36	0.50	0.70	0.88	
	SP3	0.24	0.28	0.54	0.59	0.90	0.83	1.20	1.75	2.20	
	SP4	0.40	0.48	0.98	1.15	1.65	1.82	2.50	3.71	4.88	
INPUT POWER (W)	SP1	7	8	11	12	15	18	21	38	42	
	SP2	14	16	31	32	49	60	75	123	153	
	SP3	28	33	70	78	131	151	200	311	400	
	SP4	49	62	140	165	252	335	420	670	850	
AIRFLOW (m ³ /h) ²	SP1	38	63	88	125	163	200	250	375	500	
	SP2	75	125	175	250	325	400	500	750	1000	
	SP3	113	188	263	375	488	600	750	1125	1500	
	SP4	150	250	350	500	650	800	1000	1500	2000	
AIRFLOW (l/s) ²	SP1	10	17	24	35	45	56	69	104	139	
	SP2	21	35	49	69	90	111	139	208	278	
	SP3	31	52	73	104	135	167	208	313	417	
	SP4	42	69	97	139	181	222	278	417	556	
SPECIFIC FAN POWER (W/(l/s))	SP1	0.70	0.47	0.46	0.34	0.33	0.32	0.30	0.37	0.30	
	SP2	0.67	0.46	0.63	0.46	0.54	0.54	0.54	0.59	0.55	
	SP3	0.90	0.63	0.96	0.75	0.97	0.90	0.96	0.99	0.96	
	SP4	1.17	0.90	1.44	1.19	1.39	1.51	1.51	1.61	1.53	
EXTERNAL STATIC PRESSURE (Pa)	SP1	6	5	10	8	8	10	11	11	10	
	SP2	24	21	40	30	30	38	43	44	38	
	SP3	54	48	90	68	68	85	96	98	84	
	SP4	95	85	160	120	120	150	170	175	150	
SOUND PRESSURE LEVEL (dBA)	SP1	17	17	17	18	18	18	18	18	18	
	SP2	19	20	20	19	22	23	23	24	28	
	SP3	24	22	28	28	29	30	31	32	36	
	SP4	28	27	32	34	34.5	34.5	37	39	40	
TEMPERATURE EXCHANGE EFFICIENCY (%)	SP1	84	86	88.5	87	86	85	89.5	85	89.5	
	SP2	83	82	86	83.5	84	84	86.5	84	86.5	
	SP3	81	80	82.5	81	81	82.5	83	82.5	83	
	SP4	80	79	80	78	77	79	80	80	80	
ENTHALPY EXCHANGE EFFICIENCY (%)	Heating	SP1	79	83	83.5	82.5	82	81	87	81	87
		SP2	78	76	78.5	75	76	78	78	78	78
		SP3	75.5	72	74	71	71	73.5	74	73.5	74
		SP4	73	69.5	71.5	69	68.5	71	72.5	72	72.5
	Cooling	SP1	79	83	82	82	81	81	85.5	81	85.5
		SP2	78	74.5	78	72.5	74	78	77	78	77
		SP3	74.5	70	73	68	69.5	72.5	73	72.5	73
		SP4	71	68	71	66.5	66	70	71	70.5	71
WEIGHT (kg)		20	23	30	33	38	48	54	98	110	
DIMENSIONS (mm) Width x Depth x Height		780 x 610 x 289	780 x 735 x 289	888 x 874 x 331	888 x 1016 x 331	908 x 954 x 404	1144 x 1004 x 404	1144 x 1231 x 404	1144 x 1004 x 808	1144 x 1231 x 808	
DUCT SIZE (mm)		100	150	150	200	200	250	250	(SA,RA)250 (OA,EA)270x700	(SA,RA)250 (OA,EA)270x700	
STANDARD FILTER ¹		EU-G3	EU-G3	EU-G3	EU-G3	EU-G3	EU-G3	EU-G3	EU-G3	EU-G3	
FUSE RATING (BS88) – HRC (A)		6	6	6	6	6	6	6	10	10	

Notes: Running Current, Input Power and Recovery Efficiency are based on the above airflow rate, power supply 240v, 50Hz. Sound Pressure Level measured at 1.5m under the centre of panel.

*1: EU-F7 filter available as optional parts. *2: Airflow tested to Japan industrial standard JIS B 8628. SP1, SP2, SP3 & SP4 relate to the fan speeds of the Lossnay RVX units i.e. fanspeed 1, 2, 3 & 4.

DIMENSIONS

LGH-15RVX-E

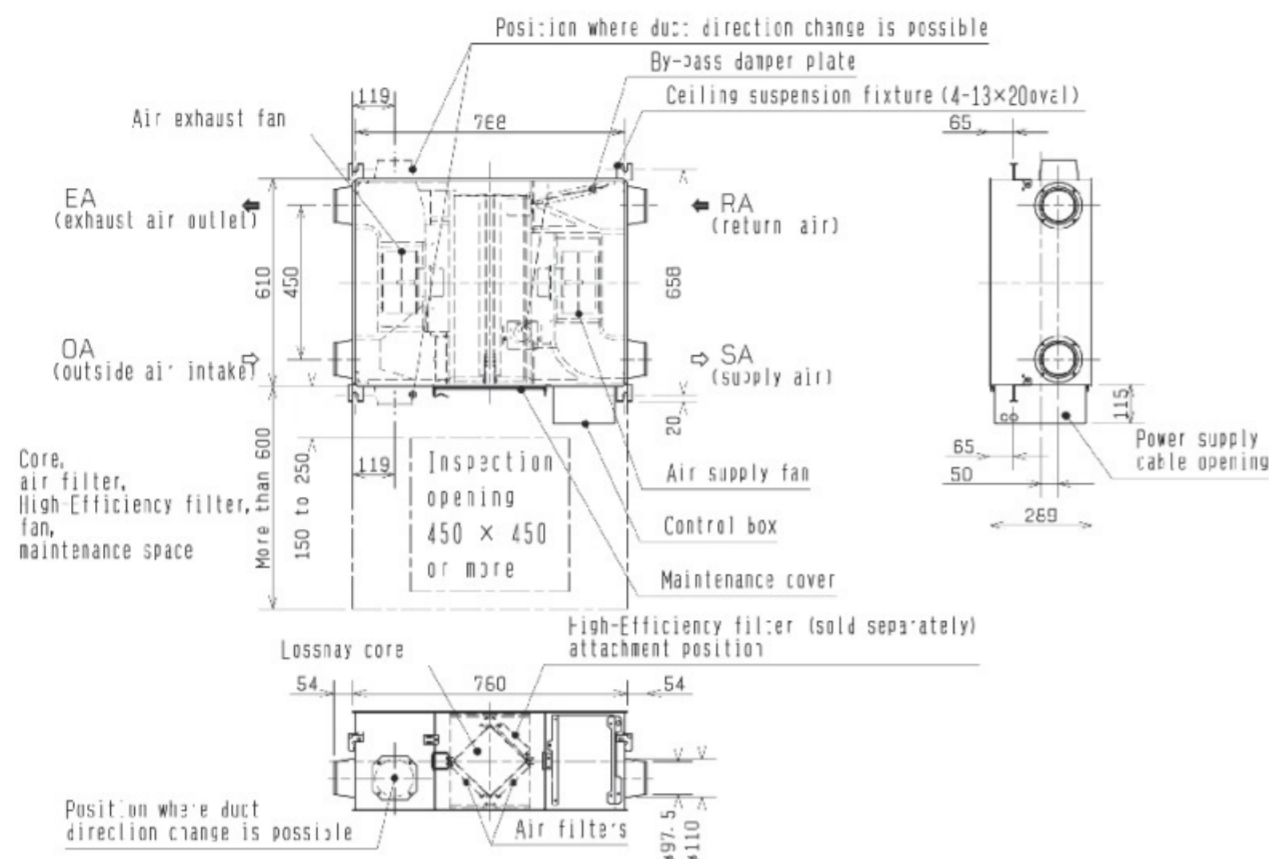

DIMENSIONS

LGH-25-100RVX-E*

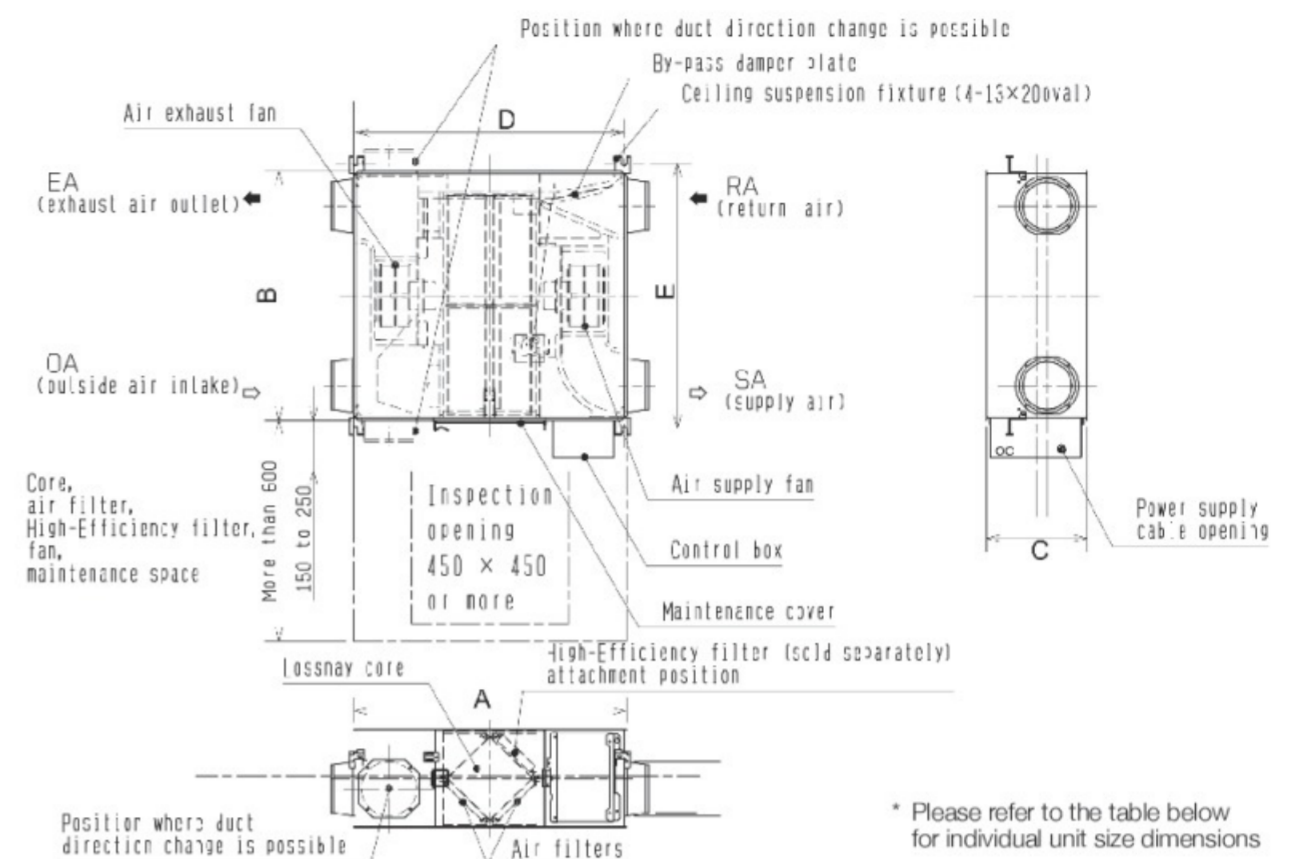

* Please refer to the table below for individual unit size dimensions

MODEL REFERENCE	DIMENSIONS			CEILING SUSPENSION FIXTURE PITCH		NOMINAL DUCT DIAMETER
	A	B	C	D	E	
LGH-25RVX-E	780	735	289	768	782	150
LGH-35RVX-E	888	874	331	875	921	150
LGH-50RVX-E	888	1016	331	875	1063	200
LGH-65RVX-E	908	954	404	895	1001	200
LGH-80RVX-E	1144	1004	404	1131	1051	250
LGH-100RVX-E	1144	1231	404	1131	1278	250

DIMENSIONS

LGH-150RVX-E

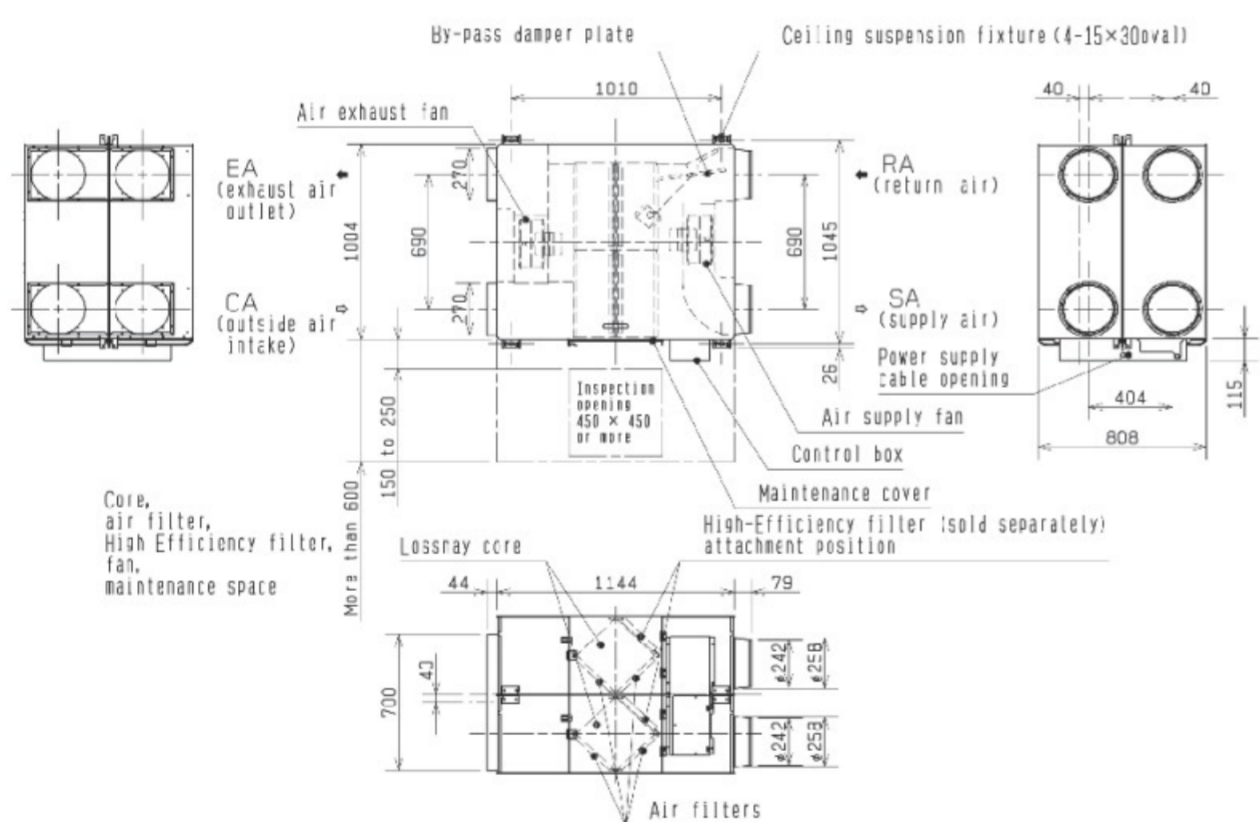

DIMENSIONS

LGH-200RVX-E

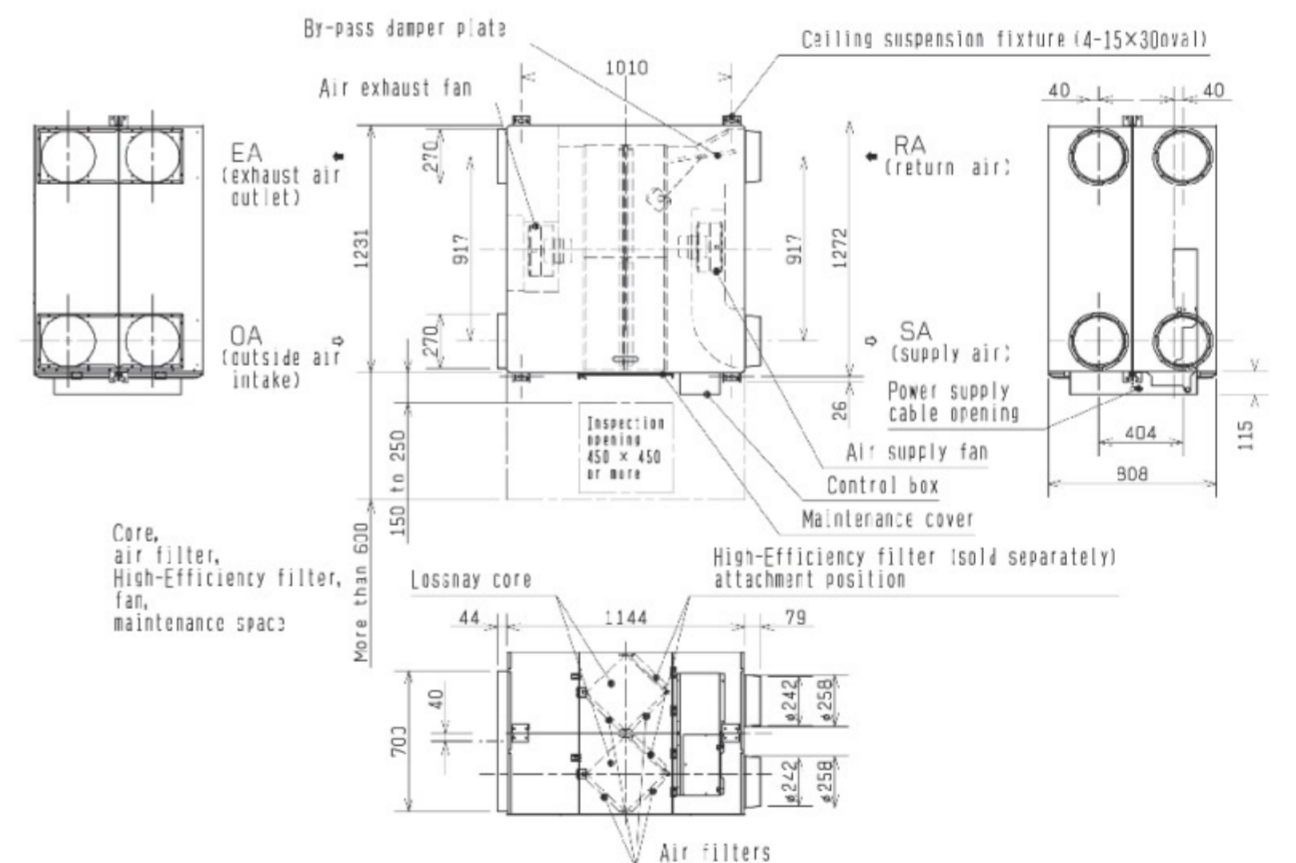

Telephone: 01707 282880

email: ventilation@meuk.mee.com

web: airconditioning.mitsubishielectric.co.uk

UNITED KINGDOM Mitsubishi Electric Europe Living Environment Systems Division
Travellers Lane, Hatfield, Hertfordshire, AL10 8XB, England General Enquiries Telephone: 01707 282880 Fax: 01707 278881

IRELAND Mitsubishi Electric Europe Westgate Business Park, Ballymount, Dublin 24, Ireland
Telephone: Dublin (01) 419 8800 Fax: Dublin (01) 419 8890 International code: (003531)

Country of origin: United Kingdom - Japan - Thailand - Malaysia. ©Mitsubishi Electric Europe 2017. Mitsubishi and Mitsubishi Electric are trademarks of Mitsubishi Electric Europe B.V. The company reserves the right to make any variation in technical specification to the equipment described, or to withdraw or replace products without prior notification or public announcement. Mitsubishi Electric is constantly developing and improving its products. All descriptions, illustrations, drawings and specifications in this publication present only general particulars and shall not form part of any contract. All goods are supplied subject to the Company's General Conditions of Sale, a copy of which is available on request. Third-party product and brand names may be trademarks or registered trademarks of their respective owners.

Note: The fuse rating is for guidance only. Please refer to the relevant databook for detailed specification. It is the responsibility of a qualified electrician/electrical engineer to select the correct cable size and fuse rating based on current regulation and site specific conditions. Mitsubishi Electric's air conditioning equipment and heat pump systems contain a fluorinated greenhouse gas, R410A (GWP:2088), R32 (GWP:675), R407C (GWP:1774) or R134a (GWP:1430). *These GWP values are based on Regulation (EU) No 517/2014 from IPCC 4th edition. In case of Regulation (EU) No.626/2011 from IPCC 3rd edition, these are as follows. R410A (GWP:1975), R32 (GWP: 550), R407C (GWP:1650) or R134a (GWP:1300).



www.greengateway.mitsubishielectric.co.uk

Mitsubishi Electric UK's commitment to the environment

Follow us @meuk_ies
Follow us @green_gateway

Mitsubishi Electric
Living Environmental Systems UK

mitsubishielectric2

thehub.mitsubishielectric.co.uk

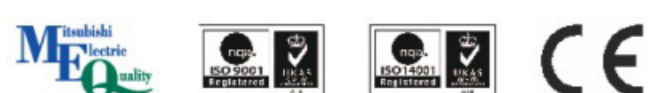

Effective as of September 2017