

**ENSURE NO STRIP OUT, DEMOLITION OR BUILDING WORKS ARE UNDERTAKEN WITHOUT THE REQUIRED LISTED BUILDING AND PLANNING CONSENTS FROM THE LOCAL AUTHORITY AND ENGLISH HERITAGE.**

DRAWINGS ARE BASED ON INFORMATION PROVIDED BY UCL.

- DRAWINGS TO BE READ IN CONJUNCTION WITH:-
- ARCHITECTURAL DRAWINGS, SCHEDULES AND SPECIFICATIONS.
  - STRUCTURAL DRAWINGS AND SPECIFICATIONS.
  - M&E DRAWINGS AND SPECIFICATIONS.
  - ACOUSTIC REPORTS.
  - FIRE STRATEGY.

ALL WORKS TO BE FULLY CO-ORDINATED WITH MEP / STRUCTURAL PROPOSALS, AS APPROPRIATE.

ALL SETTING-OUT INFORMATION TO BE CHECKED AGAINST SITE DIMENSIONS

ALL WORKS TO BE IN ACCORDANCE WITH ALL STATUTORY REQUIREMENTS. WHERE AMENDED PROPOSALS DIFFER FROM THOSE APPROVED BY LA, NEW APPROVALS TO BE OBTAINED PRIOR TO COMMENCING WORKS.

FIRE RATED COMPONENTS TO BE IN ACCORDANCE WITH OVER-ARCHING FIRE STRATEGY FOR THE IOE.

ACOUSTIC RATED COMPONENTS TO BE IN ACCORDANCE WITH ACOUSTIC STRATEGY - PREPARED BY B.H.

**LEGEND**

NEW EXTERNAL DOOR REFERENCING NUMBER

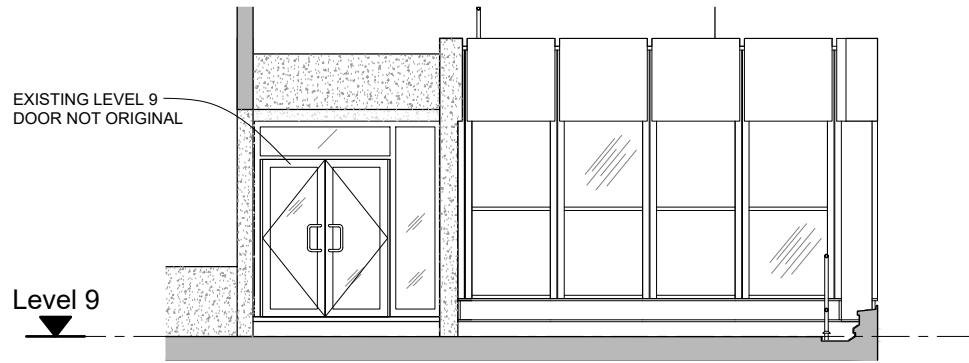

Level 9

EXISTING LEVEL 9 DOOR NOT ORIGINAL

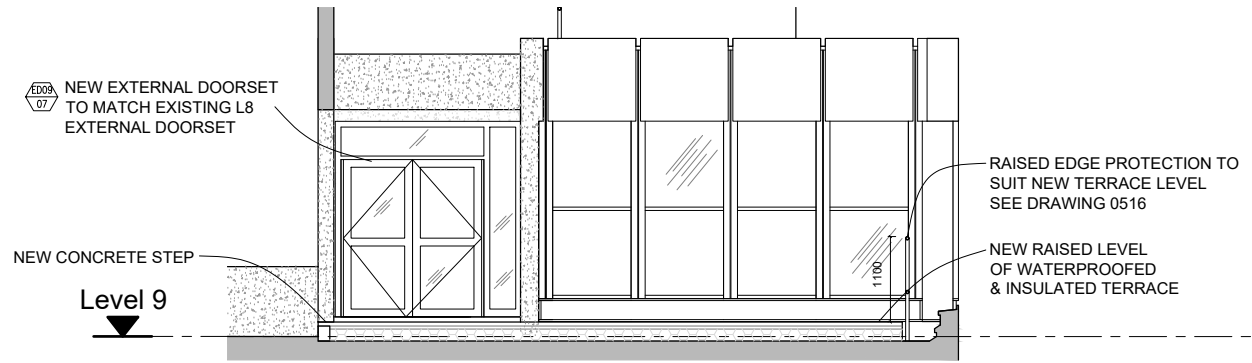

Level 9

NEW EXTERNAL DOORSET TO MATCH EXISTING L8 EXTERNAL DOORSET

NEW CONCRETE STEP

RAISED EDGE PROTECTION TO SUIT NEW TERRACE LEVEL SEE DRAWING 0516

NEW RAISED LEVEL OF WATERPROOFED & INSULATED TERRACE



Level 8



Level 8

NEW EXTERNAL DOORSET TO MATCH EXISTING

NEW CONCRETE STEP

RAISED EDGE PROTECTION TO SUIT NEW TERRACE LEVEL SEE DRAWING 0516

NEW RAISED LEVEL OF WATERPROOFED & INSULATED TERRACE



Level 7



Level 7

NEW EXTERNAL DOORSET TO MATCH EXISTING

NEW CONCRETE STEP

RAISED EDGE PROTECTION TO SUIT NEW TERRACE LEVEL SEE DRAWING 0516

NEW RAISED LEVEL OF WATERPROOFED & INSULATED TERRACE



Level 6



Level 6

NEW EXTERNAL DOORSET TO MATCH EXISTING

NEW CONCRETE STEP

RAISED EDGE PROTECTION TO SUIT NEW TERRACE LEVEL SEE DRAWING 0516

NEW RAISED LEVEL OF WATERPROOFED & INSULATED TERRACE

2 Wing A South West Elevation - Level 6-9 AS EXISTING 1:50 @ A1

3 Wing A South West Elevation - Level 6-9 AS PROPOSED 1:50 @ A1



5 Rear Wing Existing Door Level 9 PHOTO NS



6 Rear Wing Existing Door Level 6,7 &8 PHOTO NS

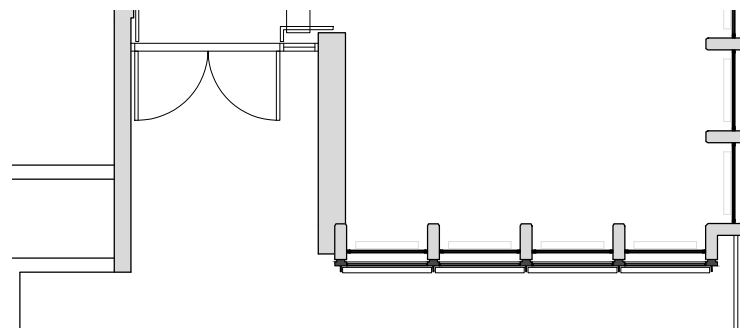

4 Typical Wing A Plan AS PROPOSED 1:50

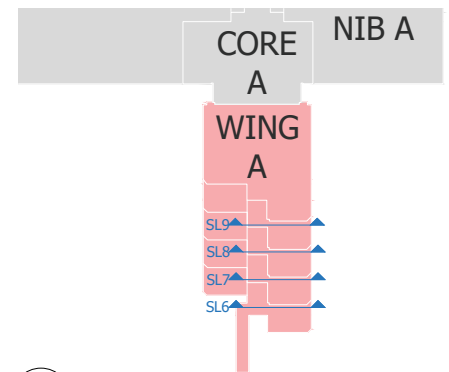

1 KEY PLAN FOR REFERENCE NTS



B	ISSUED FOR PLANNING	20.03.2020
A	PRELIMINARY ISSUE - FOR COMMENT	06.03.2020
Rev	Description	Date

Client



Job title  
University College London  
Institute of Education  
Phase 2  
20 Bedford Way, WC1H 0AL

Drawing title  
Level 6, 7, 8 & 9  
Wing Rear Door  
Planning Application 2

Scale	Date	Drawn
1:50 @ A1	Mar 20	IL

**ARCHITON LLP**  
CHARTERED ARCHITECTS . DESIGN .  
PLANNING CONSULTANTS . DEVELOPMENT .  
BUILDING COST MANAGEMENT

REGENCY HOUSE  
17 WEST STREET  
EPSOM KT16 7RL  
Email: info@architon.com

TEL: 01372 745600  
FAX: 01372 745016

Drawing No  
3147 - P2- 0502 B

ARCHITON LLP  
certified to:  
BS EN ISO 9001  
BS EN ISO 14001  
IIP Accreditation