

Pos. 003, Quantity: 1
 Door 1
 Finish: HP 6027 M
 Job: Probuild Resource Ltd - Unit 1-3 Gaunson House, Markfield Rd
 System: SMA Alitherm Plus Standard Square
 Exterior View

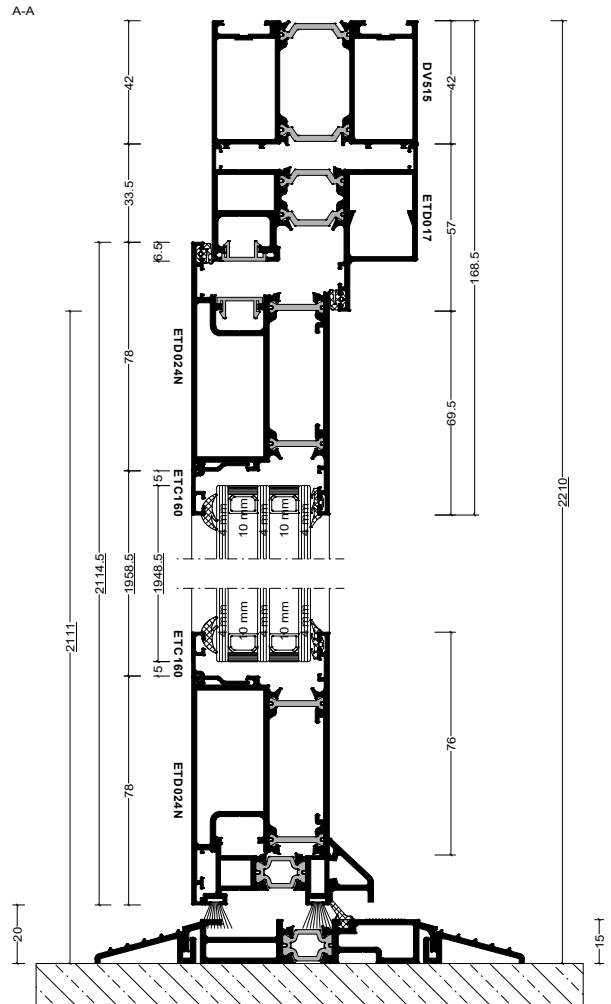

Please Note
 Ramp Section Shown on
 Threshold, but not to be
 supplied, as per request.

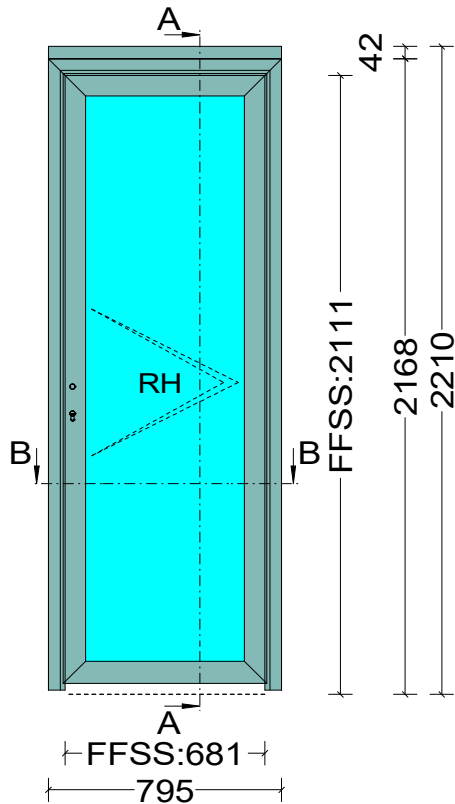