

DO NOT SCALE THIS DRAWING.

Original Drawing Size A1

Notes

PLEASE REFER TO MJC DRAWING 2714-1020 FOR NOTES

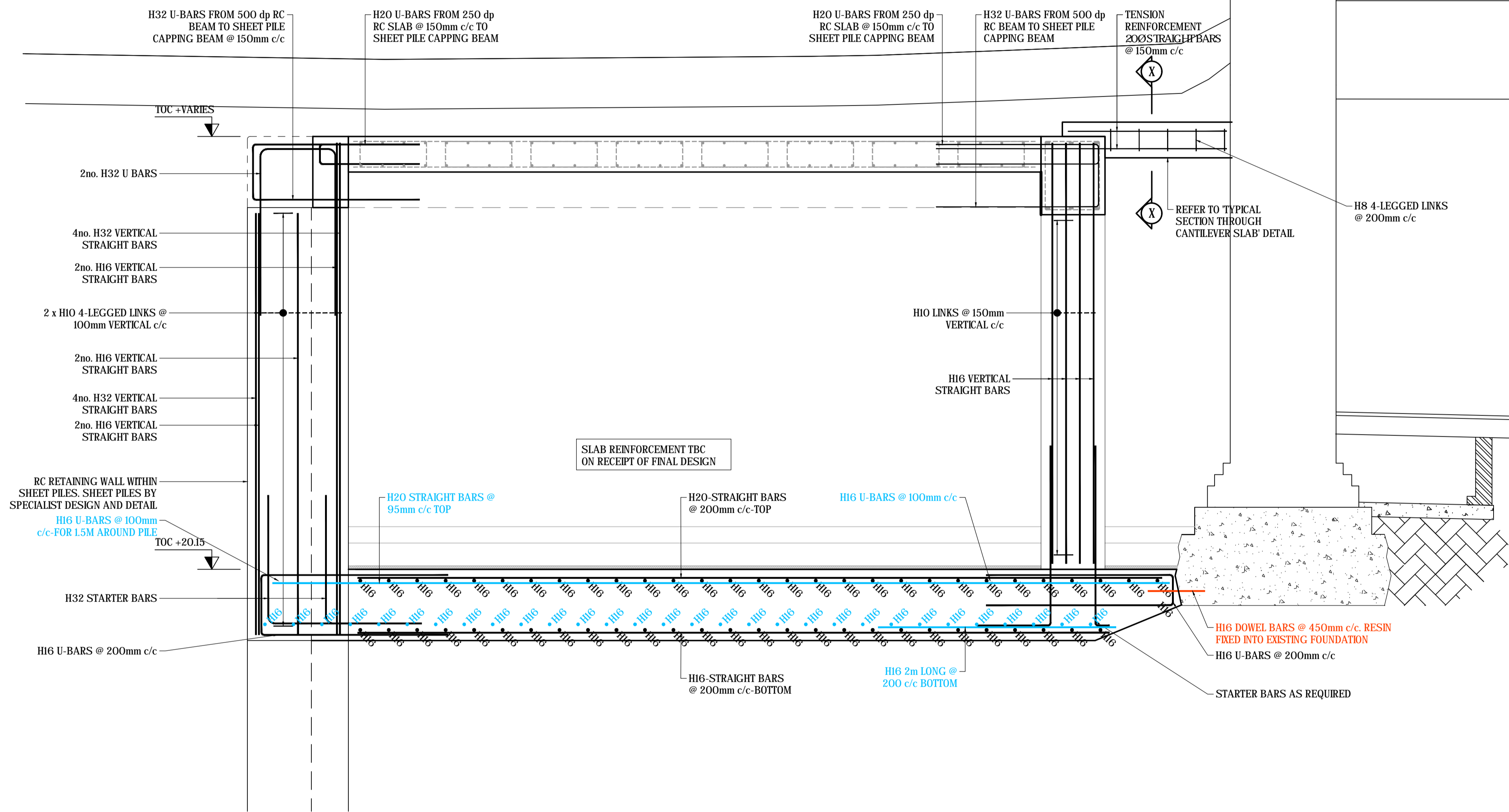

TYPICAL RC SECTION THROUGH BASEMENT BOX (SCALE 1:20 AT A1)

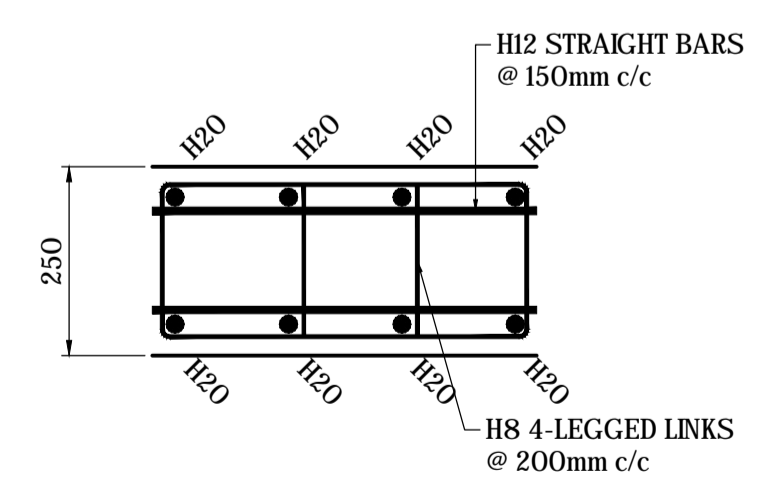

SECTION X-X (SCALE 1:10 AT A1)

TENDER ISSUE

T	08/01/20	TENDER ISSUE	DC
P1	26/11/19	BASE SLAB DESIGN ADDED	DC
P	15/11/19	PRELIMINARY ISSUE FOR COMMENTS	DC

Rev.	Date	Description	By
------	------	-------------	----

Revisions

Michael Jackson Consulting
 Chartered Structural Engineers
 204 BOLTON ROAD
 WALKDEN, WORSLEY
 MANCHESTER, M28 3BN
 Tel: 0161 790 4404
 Fax: 0161 790 4405

Client

 Shaftesbury Theatre

Site
SHAFTESBURY THEATRE

Project
PROPOSED BASEMENT

Drawing Title
TYPICAL RC SECTION THROUGH BASEMENT BOX

Scale	Date	Drawn	Checked	Passed
AS SHOWN	OCT 2019	DC		

DRG. No.
2714-1013-T

THIS DRAWING AND THE COMPUTER FILE OF THIS DRAWING ARE COPYRIGHT. THE COPYRIGHT BELONGS TO MICHAEL JACKSON CONSULTING ENGINEERS LIMITED (MJCE LIMITED). THIS DRAWING MAY THEREFORE, NOT BE REPRODUCED IN ANY FORMAT WITHOUT THE WRITTEN CONSENT OF MJCE LIMITED AND THE COMPUTER FILE MAY NOT BE TRANSFERRED WITHOUT THE WRITTEN CONSENT OF MJCE LIMITED.