

1. Outdoor Unit

1-2. Dimensional Data U-8LE1E8

Unit: mm

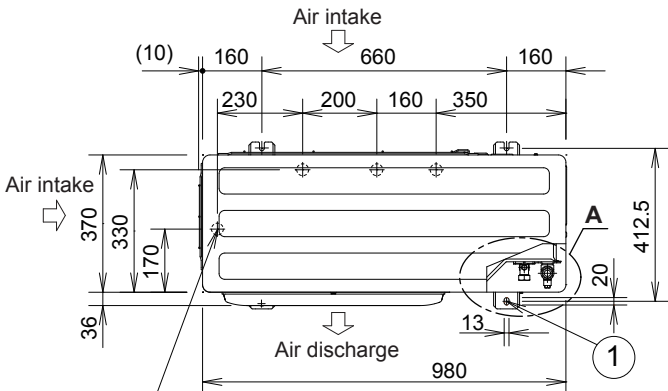

①	Mounting hole (4-R6.5), anchor bolt : M10
②	Refrigerant tubing (liquid tube), flared connection (ø9.52)
③	Refrigerant tubing (gas tube), flared connection (ø19.05)
④	Refrigerant tubing port
⑤	Electrical wiring port (ø13)
⑥	Electrical wiring port (ø22)
⑦	Electrical wiring port (ø27)
⑧	Electrical wiring port (ø35)

4 × φ 32 holes (holes for drain)
When using a drain pipe, install the drain socket (field supply) onto the drain port. Seal the other drain port with the rubber cap.

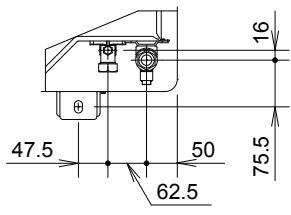
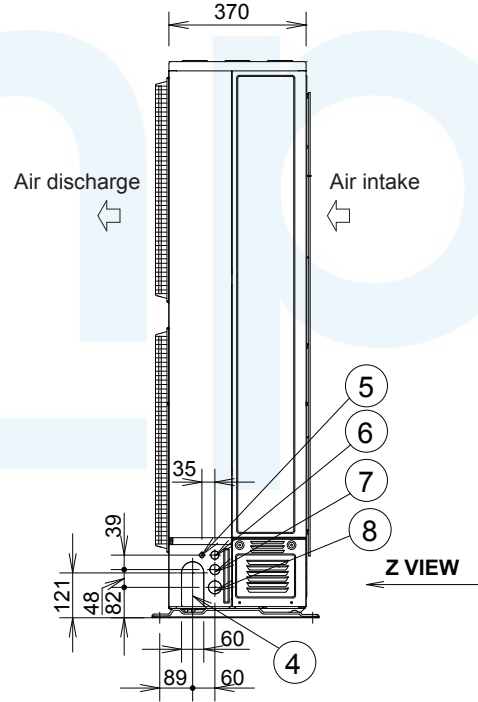
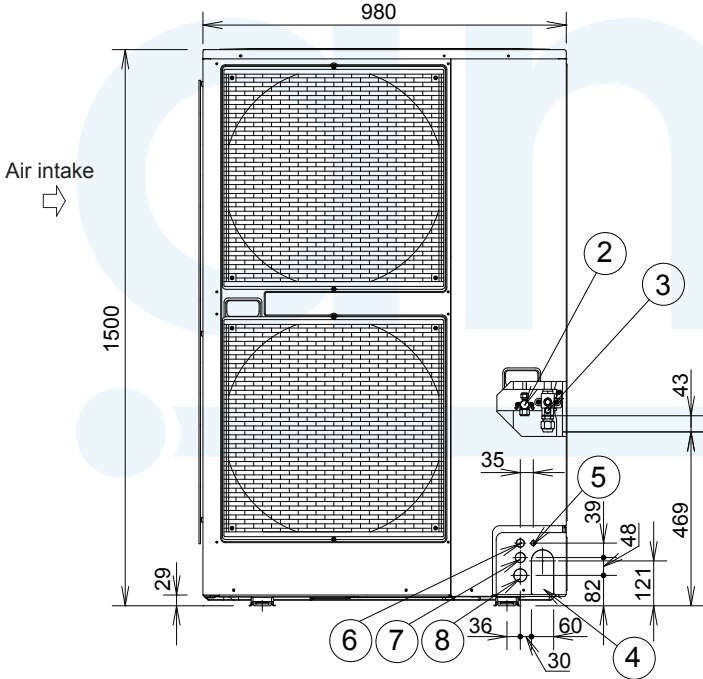

A VIEW

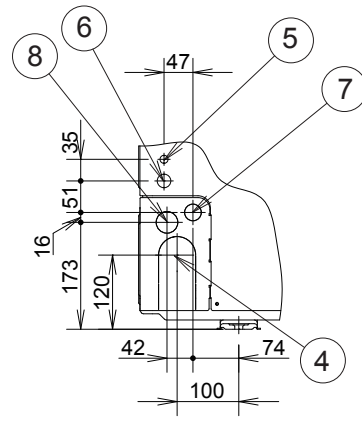

Z VIEW

