

Section C-C

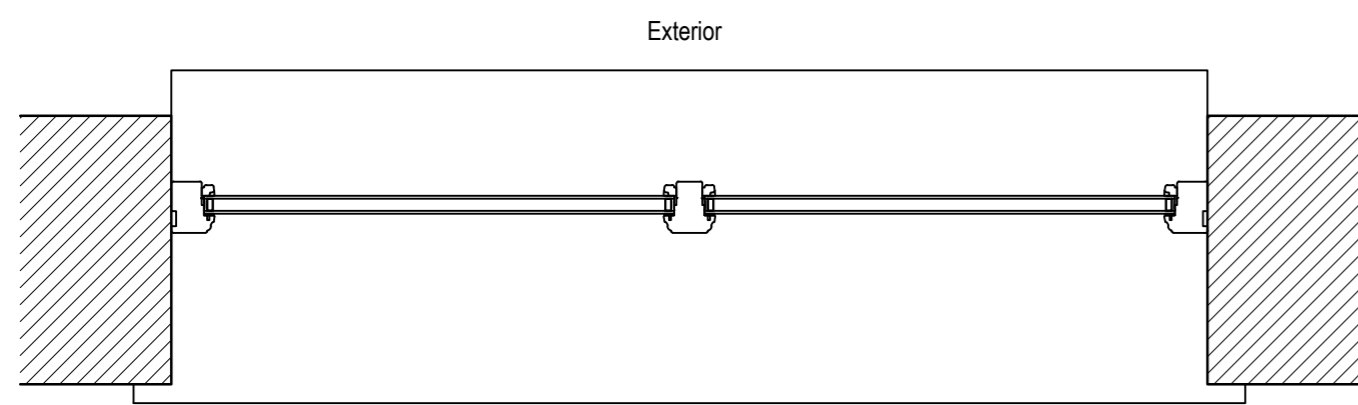

Section B-B

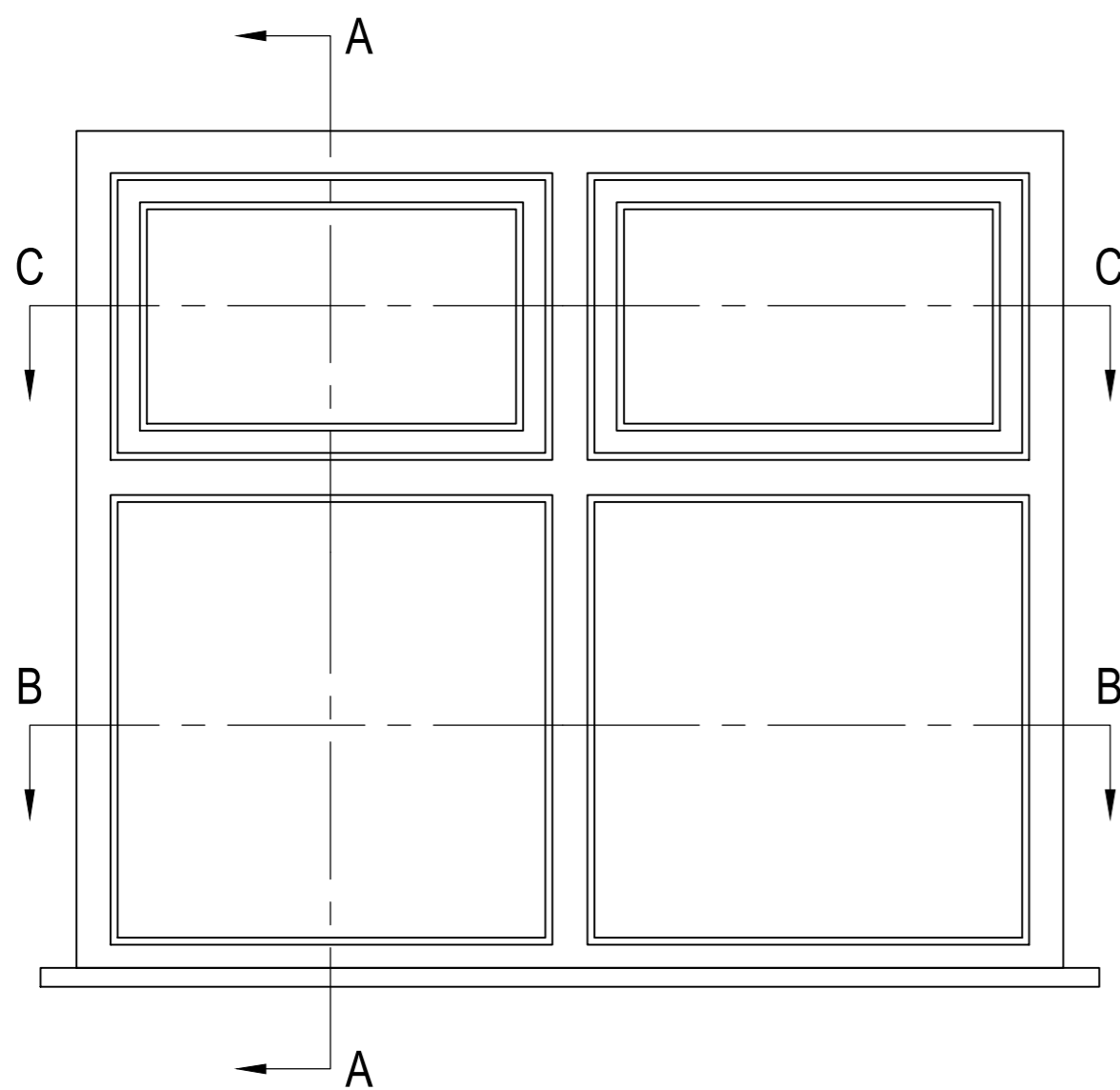

Internal Elevation

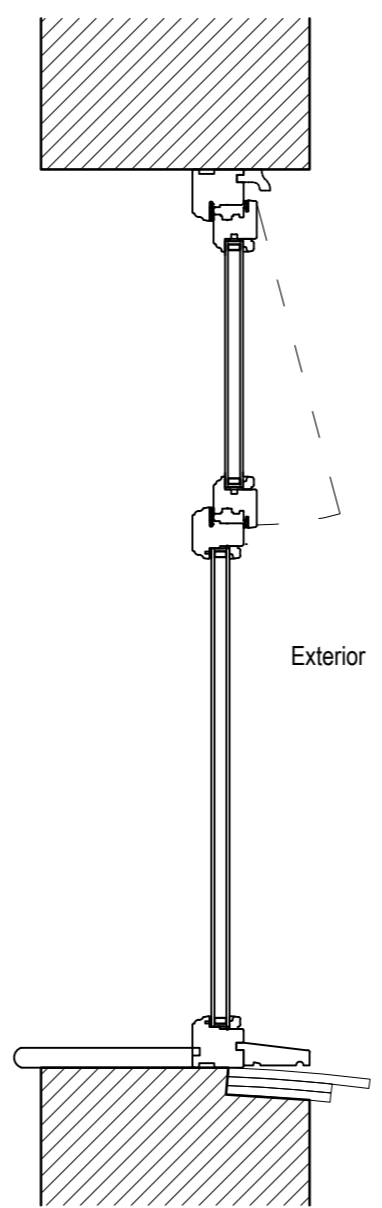

Section A-A

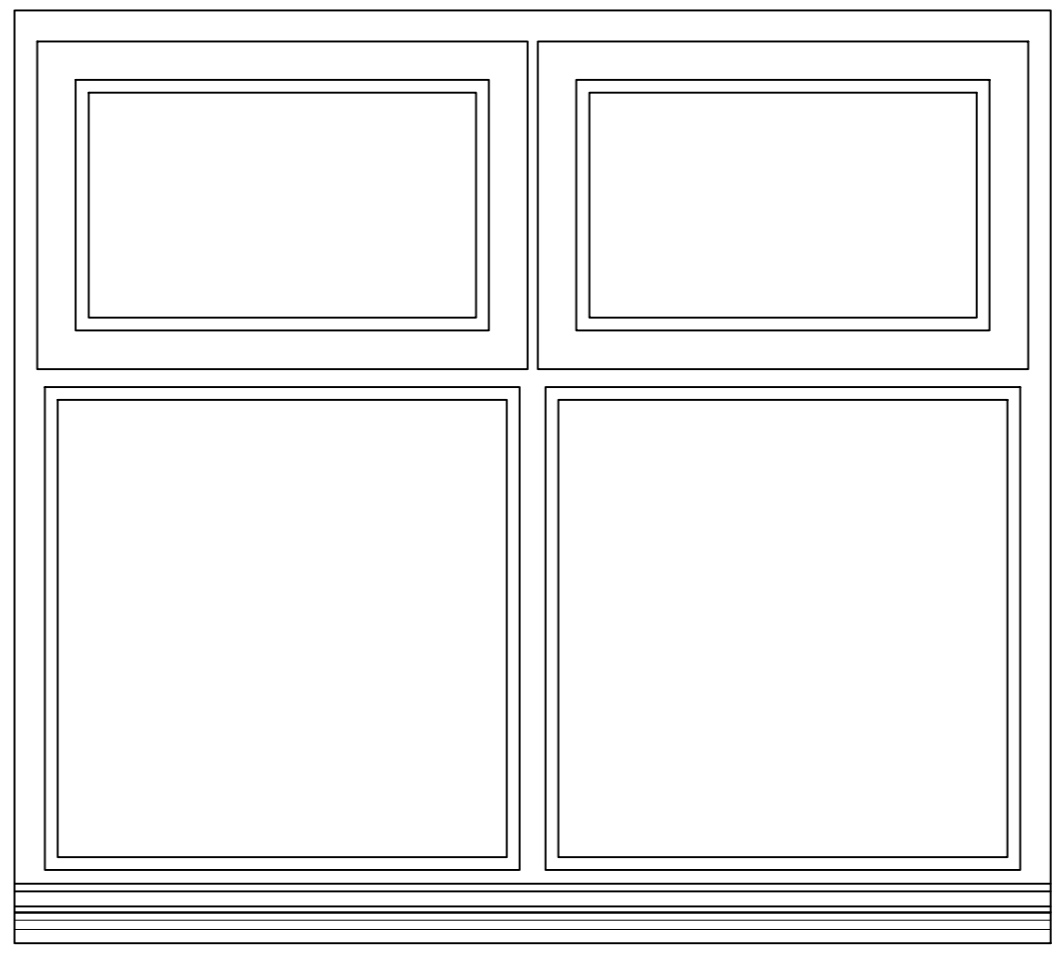

External Elevation

NOTES:
 Report all discrepancies, errors and omissions
 Do not scale from this drawing.
 Verify all dimensions on site before commencing any work or
 preparing shop drawings.
 All materials, components and workmanship are to comply with
 all the relevant British Standards, Codes of Practice, and
 appropriate manufacturers recommendations that from time to
 time shall apply.
 For all specialist work, see relevant drawings.
 This drawing and design are copyright of PELLINGS LLP

PRELIMINARY

Rev	Date	Description	Name	Pelings		Pelings LLP Northside House Mount Pleasant Barnet EN4 9EB t 020 8441 8500 f 020 8441 4016 e barnet@pellings.co.uk www.pellings.co.uk		Architects & Planning ■ Building Surveying ■ Project Management ■ Cost Consultancy ■ CDM Co-ordination																																
				<table border="1"> <tr> <td>CLIENT</td> <td colspan="5">LONDON BOROUGH OF CAMDEN</td> </tr> <tr> <td>PROJECT</td> <td colspan="5">1-5 Oriol Court, Heath Street, London NW3 6TG</td> </tr> <tr> <td>DATE</td> <td>07/02/20</td> <td>SCALE</td> <td>1:10</td> <td>DRAWN</td> <td>MV</td> <td>CHK</td> <td>JS</td> </tr> <tr> <td>TITLE</td> <td colspan="5">Typical Window Detail As Proposed</td> <td>DRAWING NO.</td> <td colspan="2">510 062 106</td> <td colspan="2"></td> </tr> </table>		CLIENT	LONDON BOROUGH OF CAMDEN					PROJECT	1-5 Oriol Court, Heath Street, London NW3 6TG					DATE	07/02/20	SCALE	1:10	DRAWN	MV	CHK	JS	TITLE	Typical Window Detail As Proposed					DRAWING NO.	510 062 106							
CLIENT	LONDON BOROUGH OF CAMDEN																																							
PROJECT	1-5 Oriol Court, Heath Street, London NW3 6TG																																							
DATE	07/02/20	SCALE	1:10	DRAWN	MV	CHK	JS																																	
TITLE	Typical Window Detail As Proposed					DRAWING NO.	510 062 106																																	