

view from landing

A

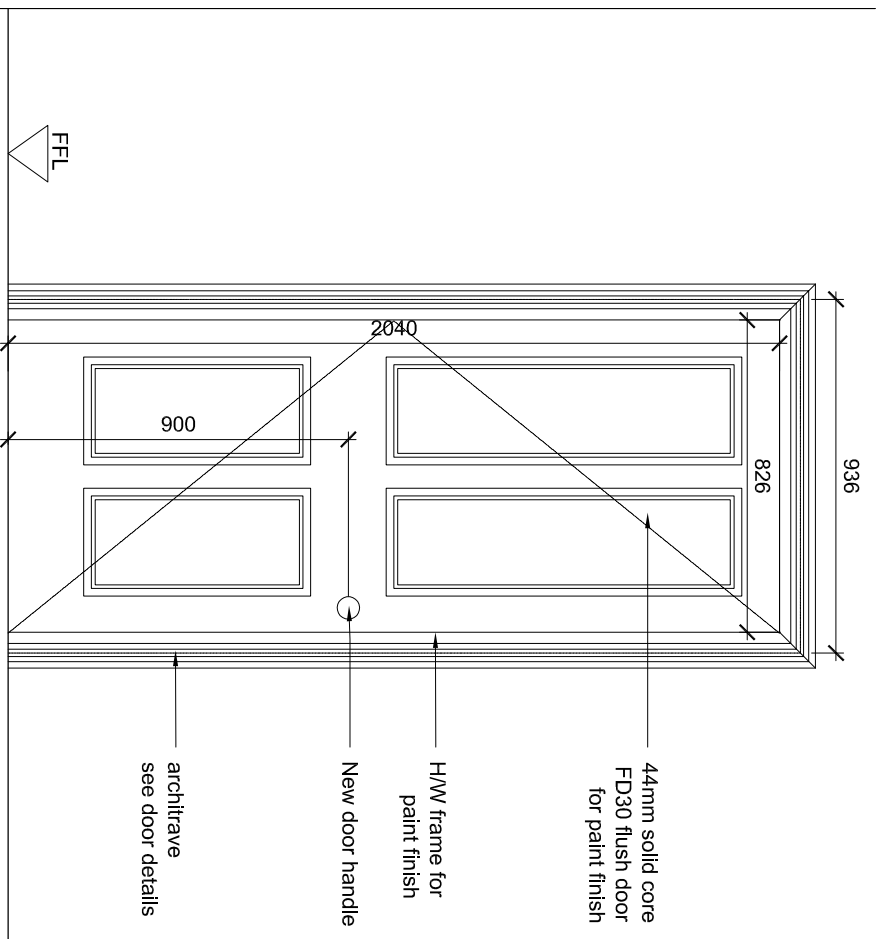

view from landing

B

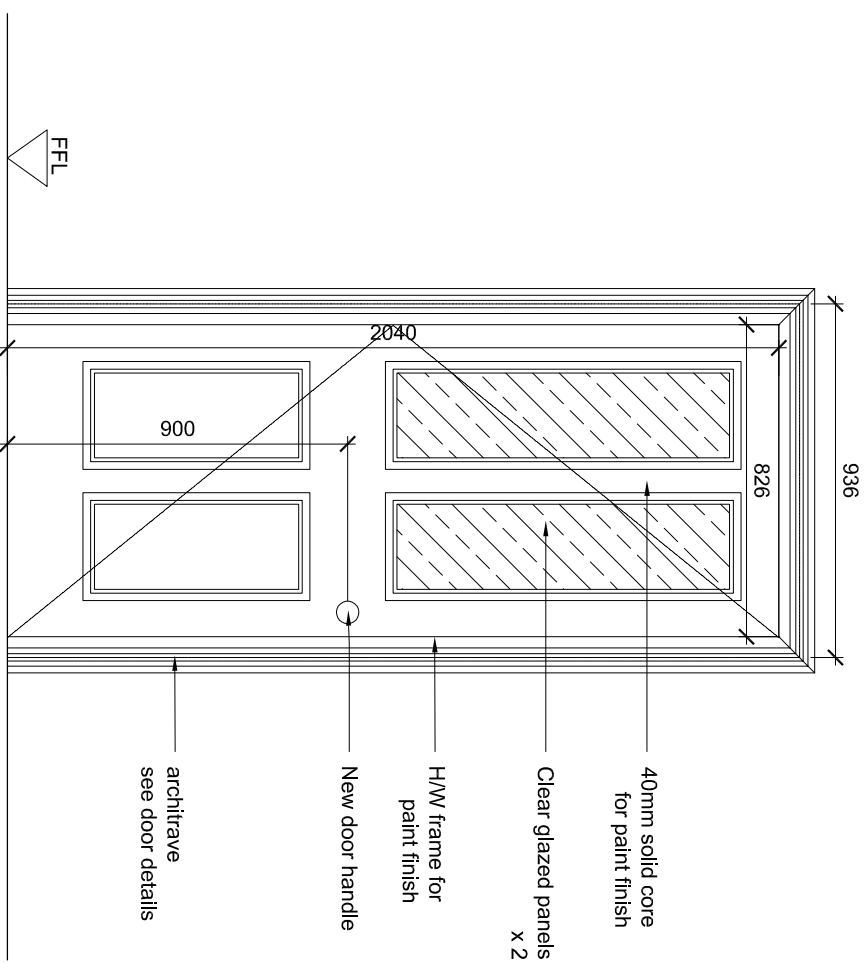

view from living room

C

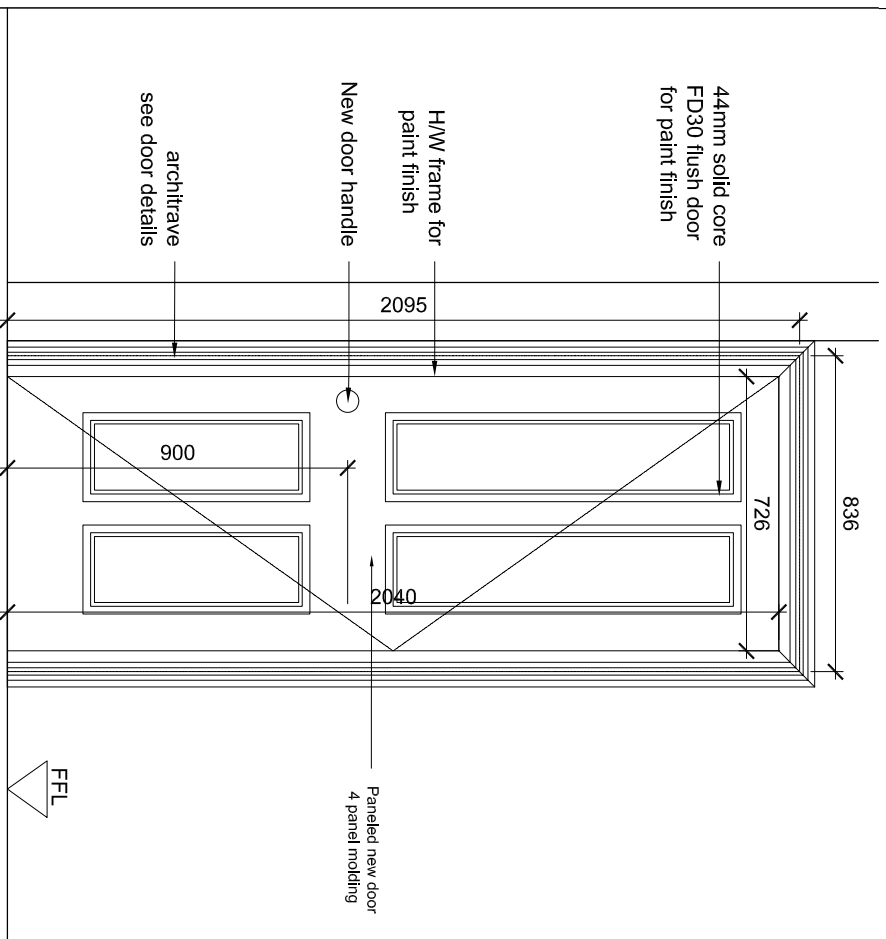

view from kitchen

D

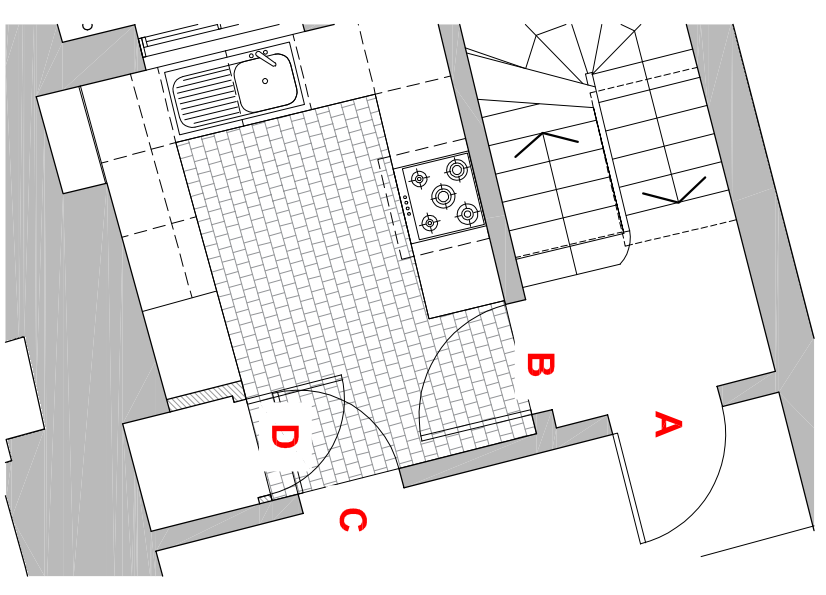

1st floor key

PLANNING CONDITIONS

THIS DRAWING IS NOT TO BE SCALED. ONLY DIMENSIONS ARE TO BE USED. ALL DIMENSIONS ARE TO FACE UNLESS OTHERWISE STATED. CONTRACTORS ARE TO CHECK ALL DIMENSIONS BEFORE WORK COMMENCES AND REFER ANY APPARENT DISCREPANCY TO THE ARCHITECT. THIS DRAWING IS THE SOLE PROPERTY OF M+A PARTNERSHIP LIMITED AND MAY NOT BE COPIED OR REPRODUCED IN ANY MANNER WHATSOEVER WITHOUT THE OWNERS WRITTEN CONSENT. © COPYRIGHT.

PROJECT 21
Warren Street
London W1
DRAWING
Condition E
Proposed Internal
Door Schedule First Floor

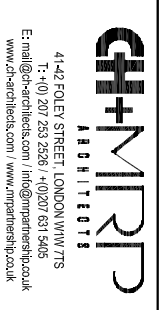

4142 EOLEY STREET, LONDON W1W 7TS
T: +44 (0) 20 7232 2851 / F: +44 (0) 20 7631 4405
E: mail@ch+mptd.com / info@ch+mptd.co.uk
www.ch+mptd.co.uk / www.mptdarchitects.co.uk

DATE:	27/02/2020	SCALE:	1:20@A3	DRAWN:	GMF
DWG No:	3213_085		1:10@A1	REV. No:	/
FILE:	3213_085-089 Proposed Internal Door Schedule Page 1.dwg				

Ⓐ 1st floor proposed doors replaced in existing openings