



- KEY**
- Existing metal brackets to be painted and made good. Finish RAL 9004 Signal Black.
  - Hung LED light box made of acrylic sheet with hidden fixing. Light to be even with no LED spot visible.
  - Black centred lettering in both sides of the box. Font: Helvetica Neue Ultra Light

**Copyright pH+**  
 No implied licence exists. This drawing should not be used to calculate areas for the purpose of valuation. Do not scale this drawing. All dimensions to be checked on site by the contractor and such dimensions to be their responsibility. All work must comply with relevant British Standards and Building Regulations requirements. Drawing errors and omissions to be reported to the architect.

**Revisions**

Rev.	By	Date	Description
P2	LLG	20/01/20	Issue for Planning

**1** North Elevation - Symes Mews  
 1:100

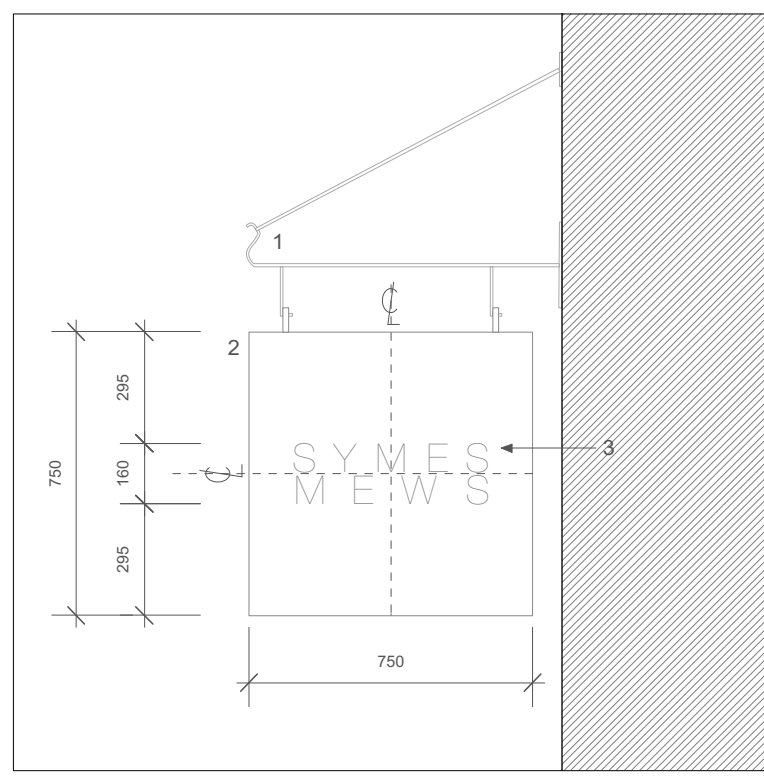
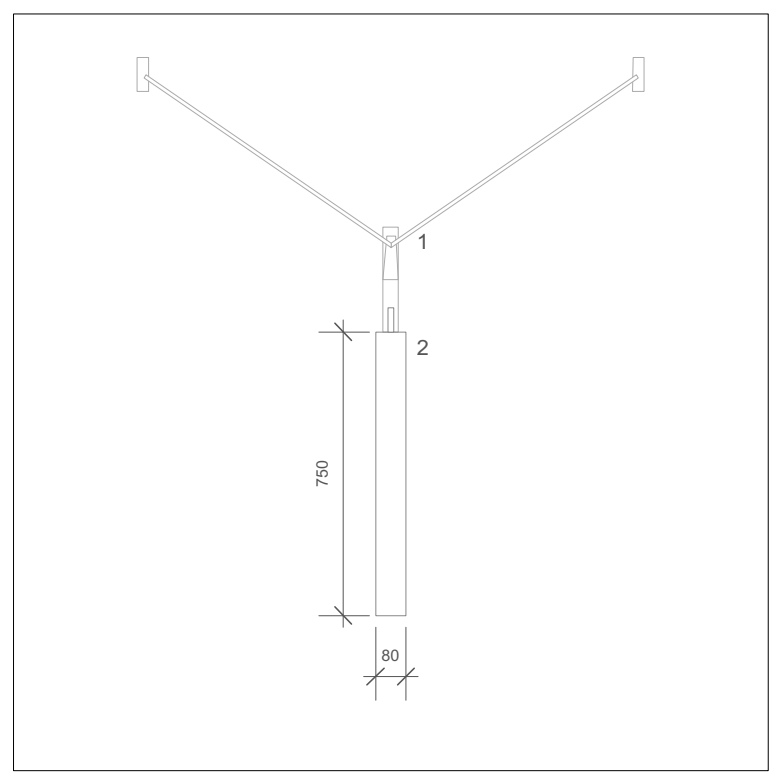

**2** Signage Side Detail  
 1:20

**3** Signage Front Detail  
 1:20



**4** Visual

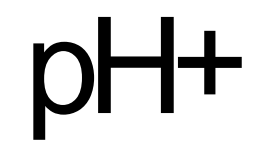

**Puncher Hamilton Plus Ltd**  
 Albion Mills, 3rd Floor  
 18 East Tenter Street  
 London E1 8DN  
 t : +44 (0)20 7613 1965  
 e : mail@phplusarchitects.com  
 w : www.phplusarchitects.com

**Project Title**  
 Symes Works  
**Project Address**  
 15a - 37 Camden High Street  
 London NW1 7JE

**Drawing Name**  
 Proposed Signage

**Status**  
 Planning

**Scale**  
 A3 varies  
 A1

**Proj. No.** 861  
**Area** - X  
**Dwg. No.** 0420  
**Type** - GA  
**Rev** - P2