

Internal Room Elevation
Scale: 1:10

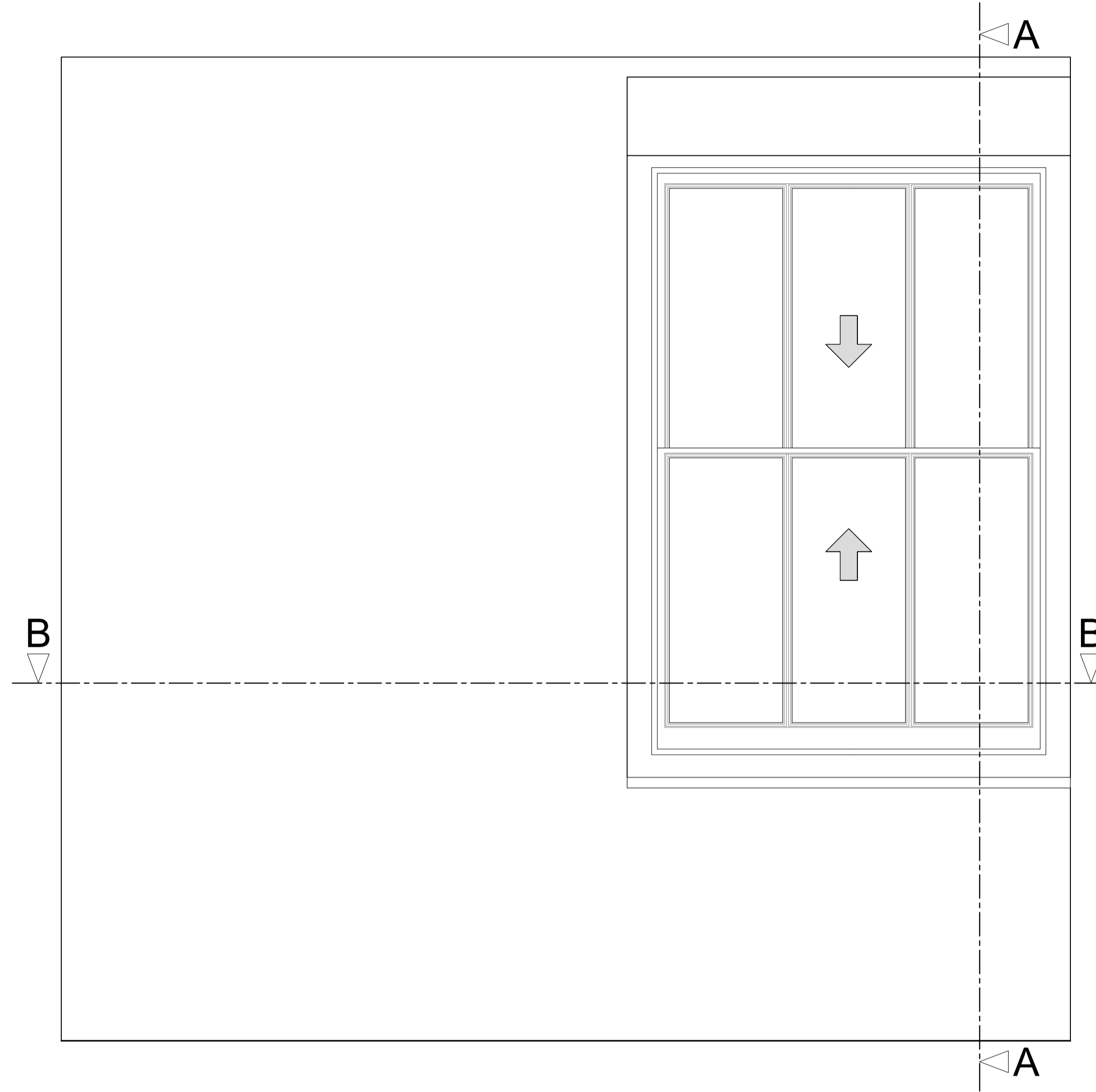

Section A-A through External Wall
Scale: 1:10

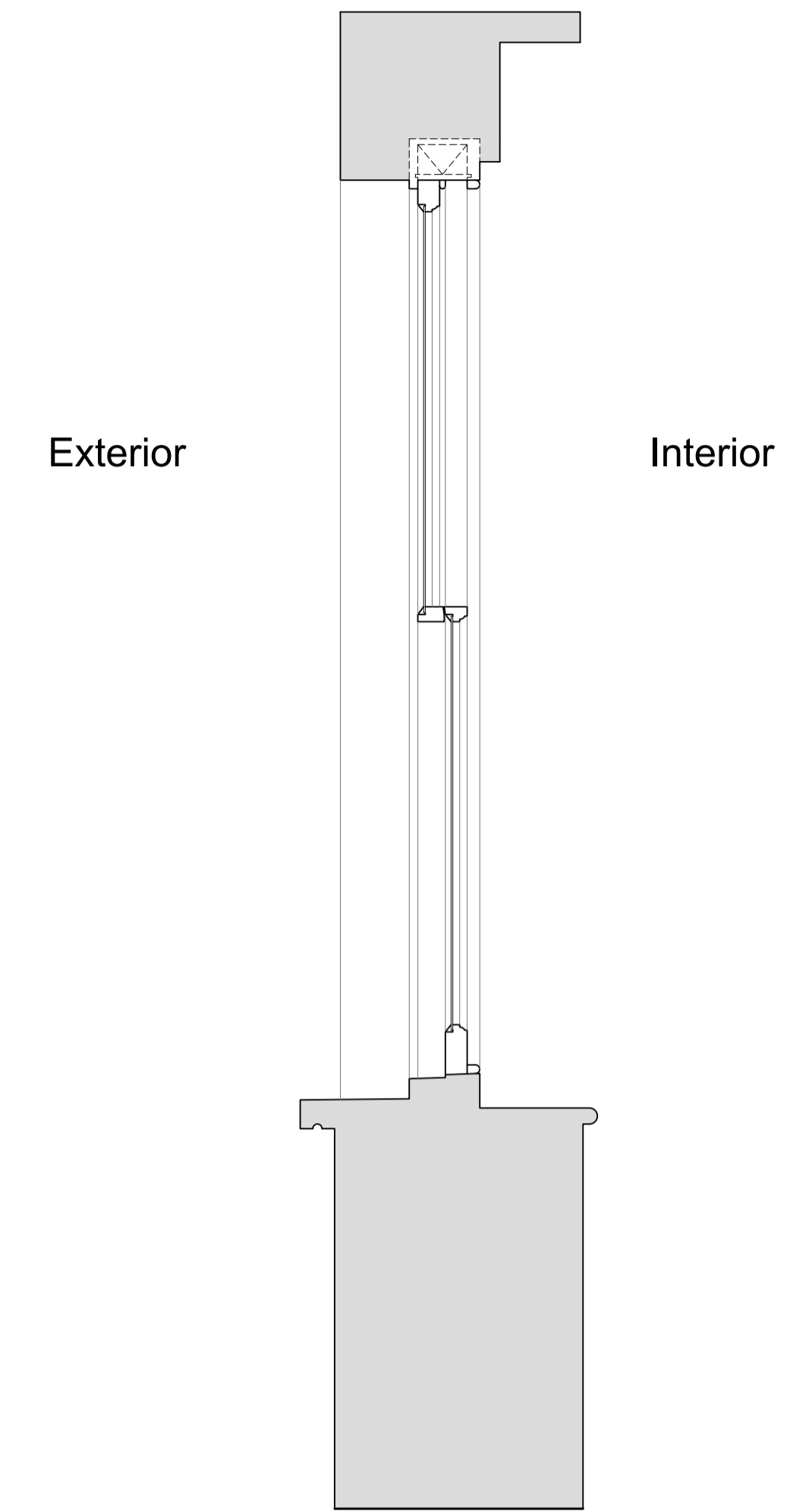

Plan Section B-B
Scale: 1:10

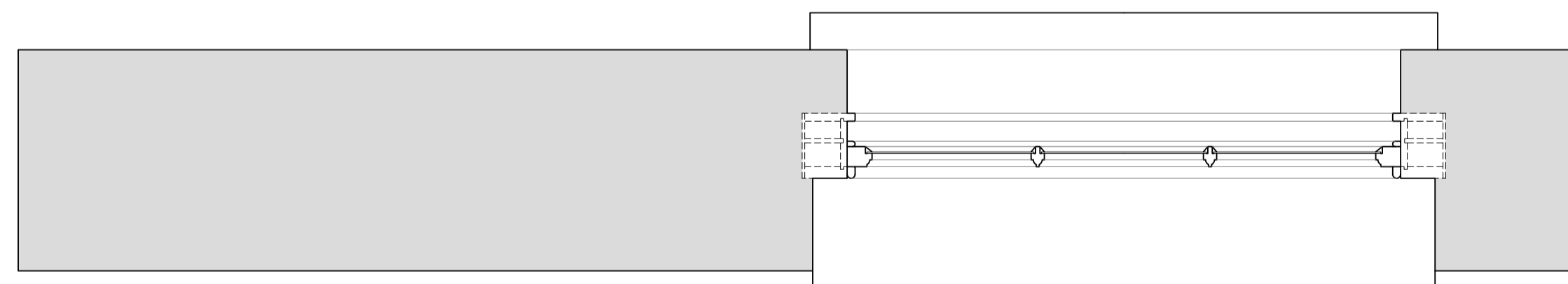

Revision	Date	Amendment
1.0	24-10-2019	Issued for listed building consent application

Do not reproduce this drawing without written permission
All dimensions are in millimetres unless stated otherwise

Drawing Not For Construction

HS2

High Speed (HS2) Limited
1st-3rd Floor
The Podium
1 Eversholt Street
London NW1 2DN

COSTAIN SKANSKA

Costain Skanska Joint Venture
2nd Floor
Addison Lee Compound
Granby Terrace
London NW1 3SA

Site Address:
1 Mornington Crescent, Flat 4, London NW1

Drawing Title:
Second Floor- Bedroom: EXISTING Window Joinery Details -
Sheet 1 of 3

Drawn by: AP & PB
Checked by: OB
Presentation Scale: as shown @ A1

Date: 18-10-2019
Drawing No: WPI P066 NI - 1 MC 4-EX-SF-J-01
Revision: 1.0

Internal Room Elevation with Secondary Glazing Installed

Scale: 1:10

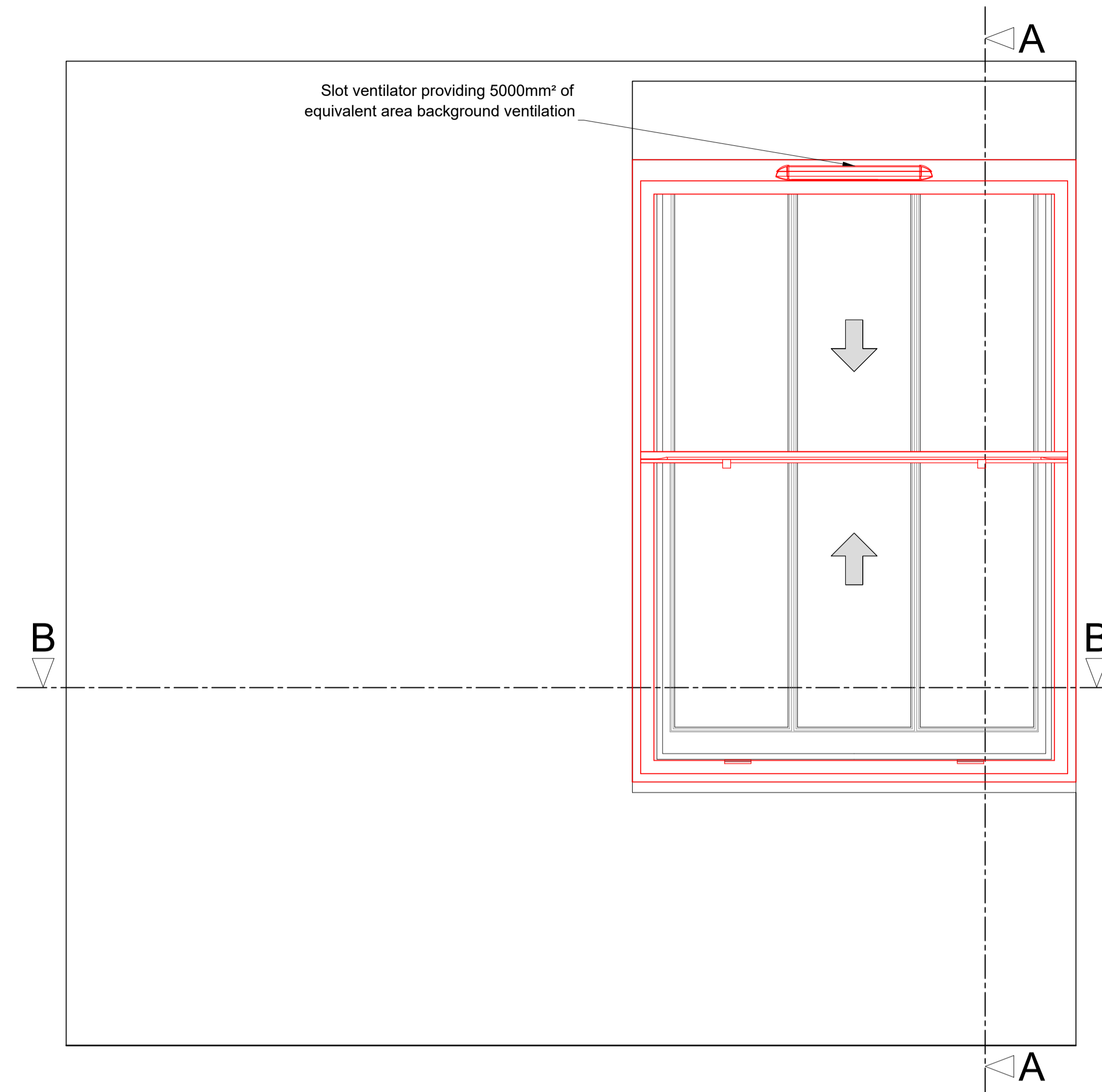

Section A-A through External Wall with Secondary Glazing Installed

Scale: 1:10

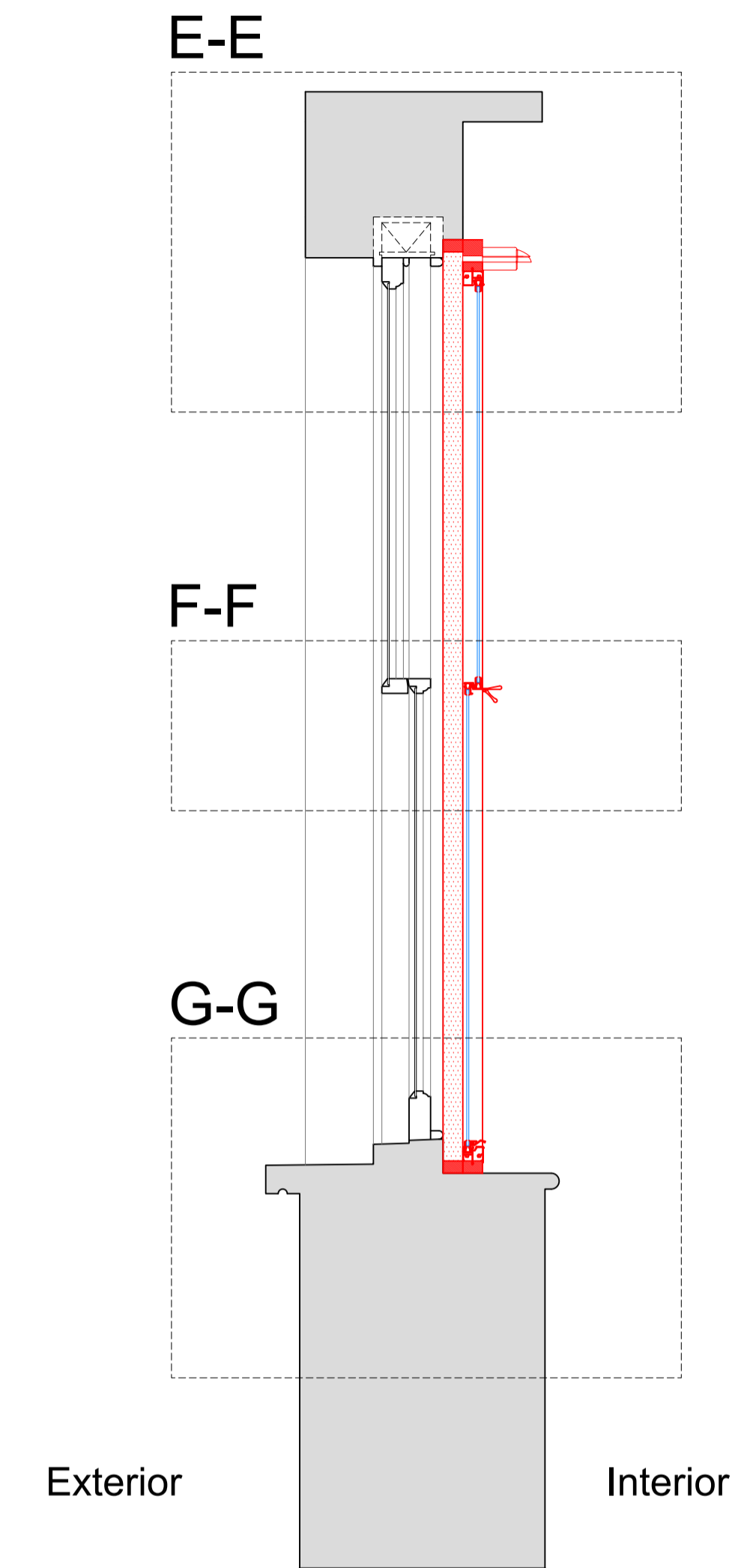

Plan Section B-B with Secondary Glazing Installed

Scale: 1:10

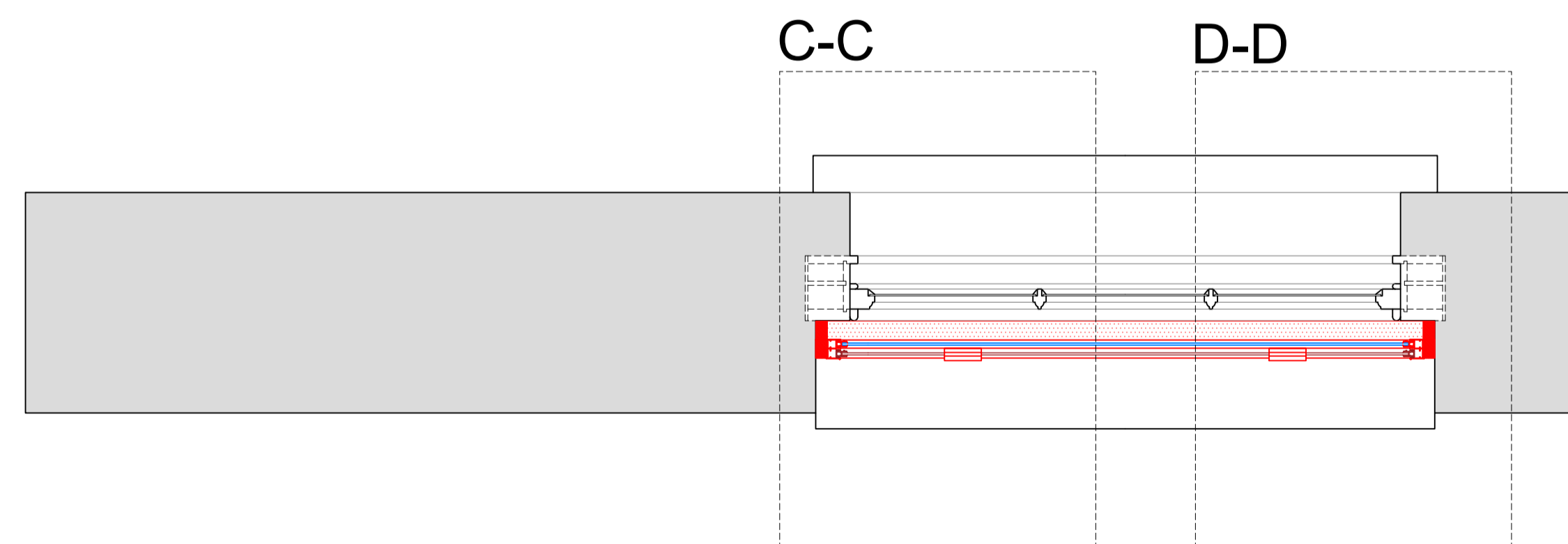

SECONDARY GLAZING SHOWN IN RED FOR VISUAL CLARITY ONLY

Revision	Date	Amendment
1.0	24-10-2019	Issued for listed building consent application

Do not reproduce this drawing without written permission
All dimensions are in millimetres unless stated otherwise

Drawing Not For Construction

HS2

High Speed (HS2) Limited
1st-3rd Floor
The Podium
1 Eversholt Street
London NW1 2DN

CDSTAIN SKANSKA

Costain Skanska Joint Venture
2nd Floor
Addison Lee Compound
Granby Terrace
London NW1 3SA

Site Address:
1 Mornington Crescent, Flat 4, London NW1

Drawing Title:
Second Floor- Bedroom: PROPOSED Secondary Glazing Details -
Sheet 2 of 3

Drawn by: AP & PB
Checked by: OB
Presentation Scale: as shown @ A1

Date: 18-10-2019
Drawing No: WPI P066 NI - 1 MC 4-PR-SF-J-01.1
Revision: 1.0

Section C-C
Scale: 1:5 on A1

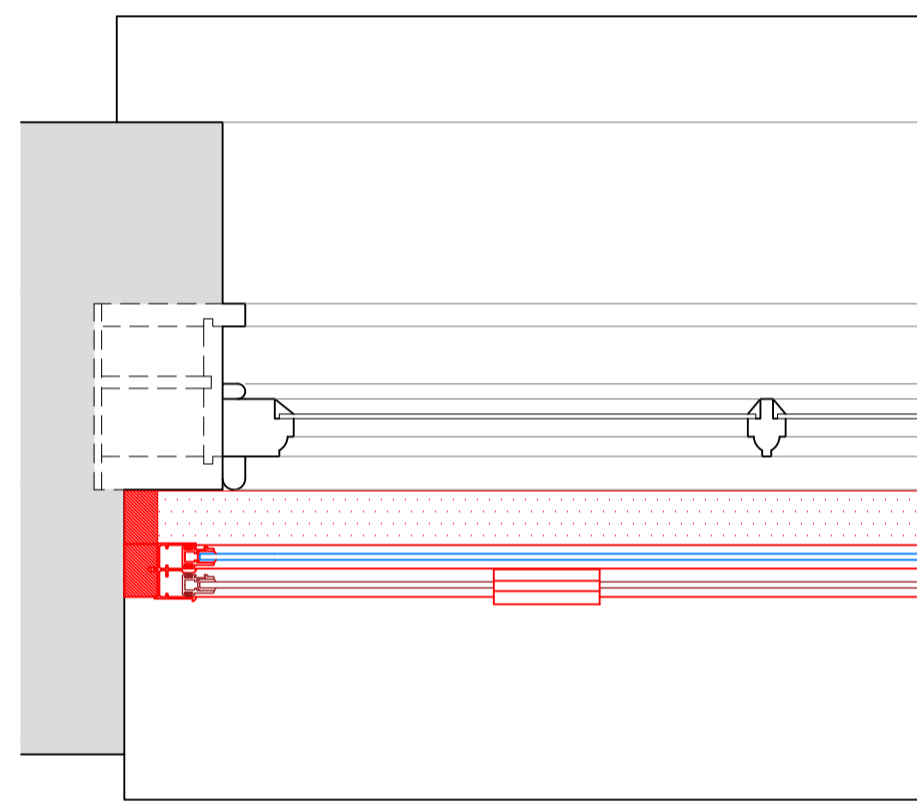

Section D-D
Scale: 1:5 on A1

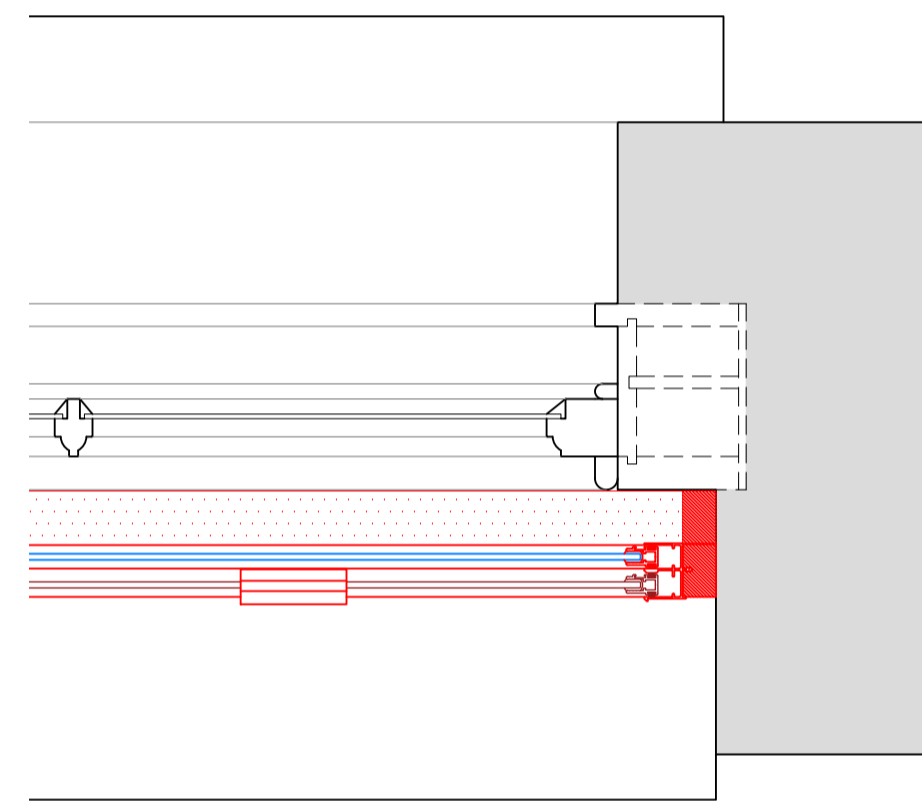

Section E-E
Scale: 1:5 on A1

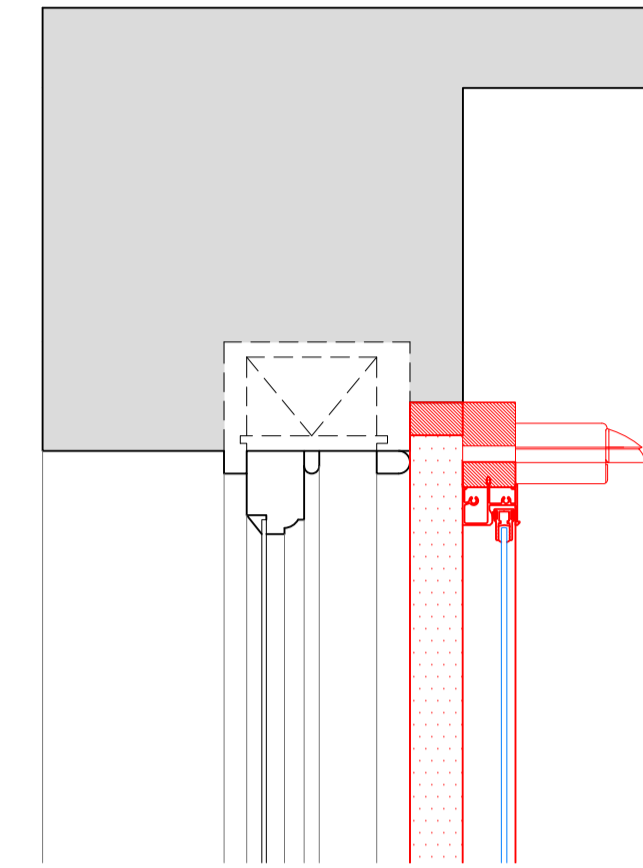

Section F-F
Scale: 1:5 on A1

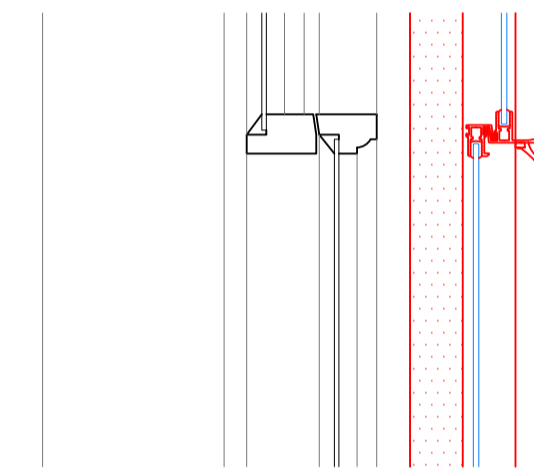

Section G-G
Scale: 1:5 on A1

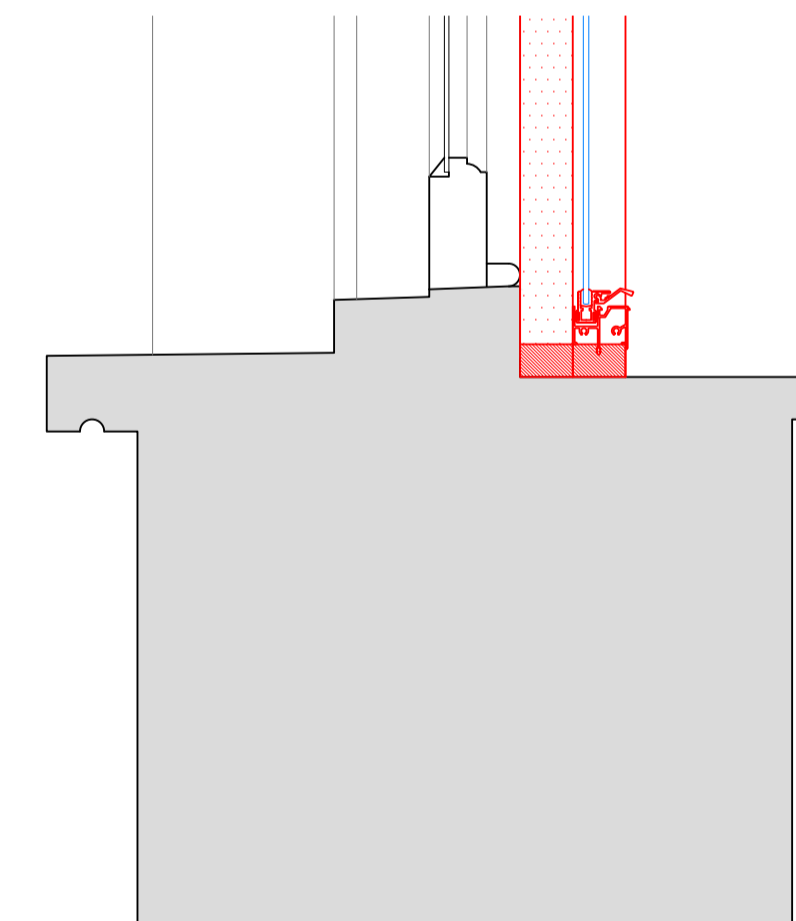

SECONDARY GLAZING SHOWN IN RED FOR VISUAL CLARITY ONLY

Revision	Date	Assessment
1.0	24-10-2019	Issued for listed building consent application

Do not reproduce this drawing without written permission
All dimensions are in millimetres unless stated otherwise

Drawing Not For Construction

HS2

High Speed (HS2) Limited
1st-3rd Floor
The Podium
1 Eversholt Street
London NW1 2DN

COSTAIN SKANSKA

Costain Skanska Joint Venture
2nd Floor
Addison Lee Compound
Granby Terrace
London NW1 3SA

Site Address:
1 Mornington Crescent, Flat 4, London NW1

Drawing Title:
Second Floor- Bedroom: PROPOSED Secondary Glazing Details -
Sheet 3 of 3

Drawn by: AP & PB
Checked by: OB
Presentation Scale: 1:5 @ A1

Date: 18-10-2019
Drawing No: WPI P066 NI - 1 MC 4-PR-SF-J-01.2
Revision: 1.0

Internal Room Elevation
Scale: 1:10

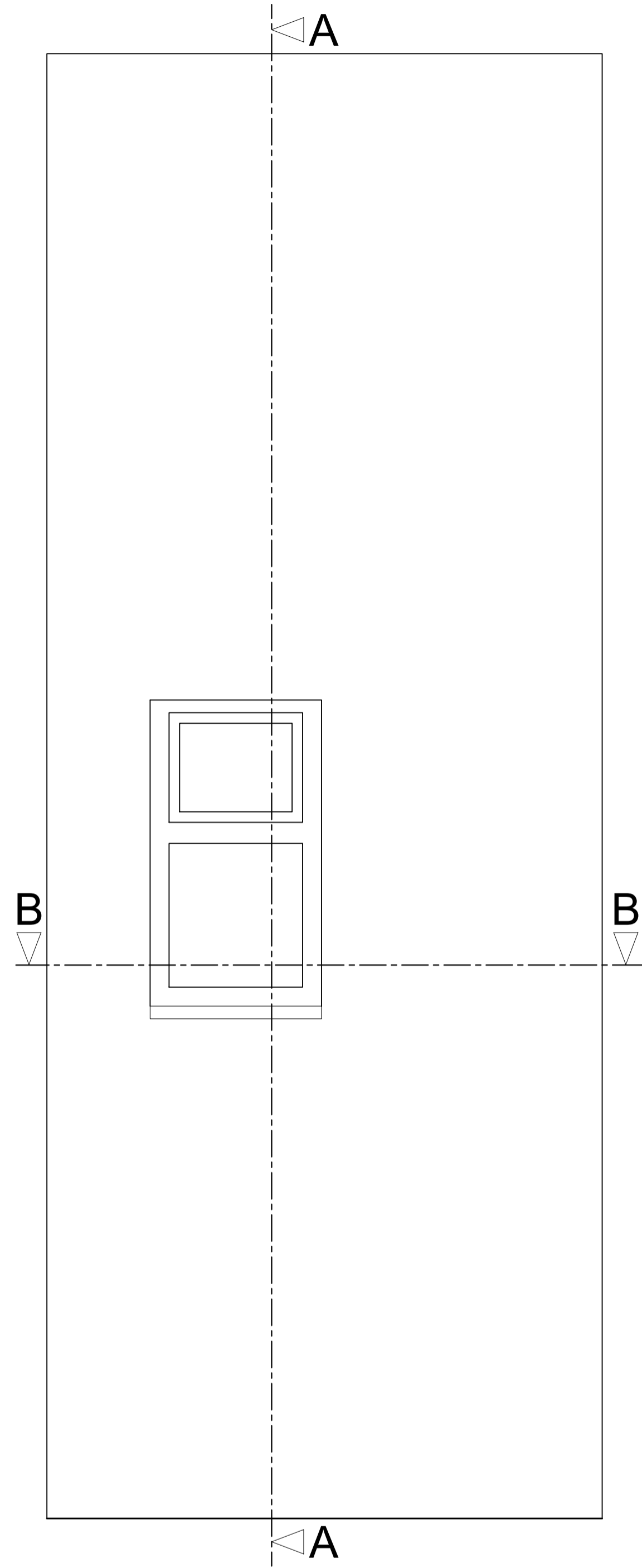

Section A-A through External Wall
Scale: 1:10

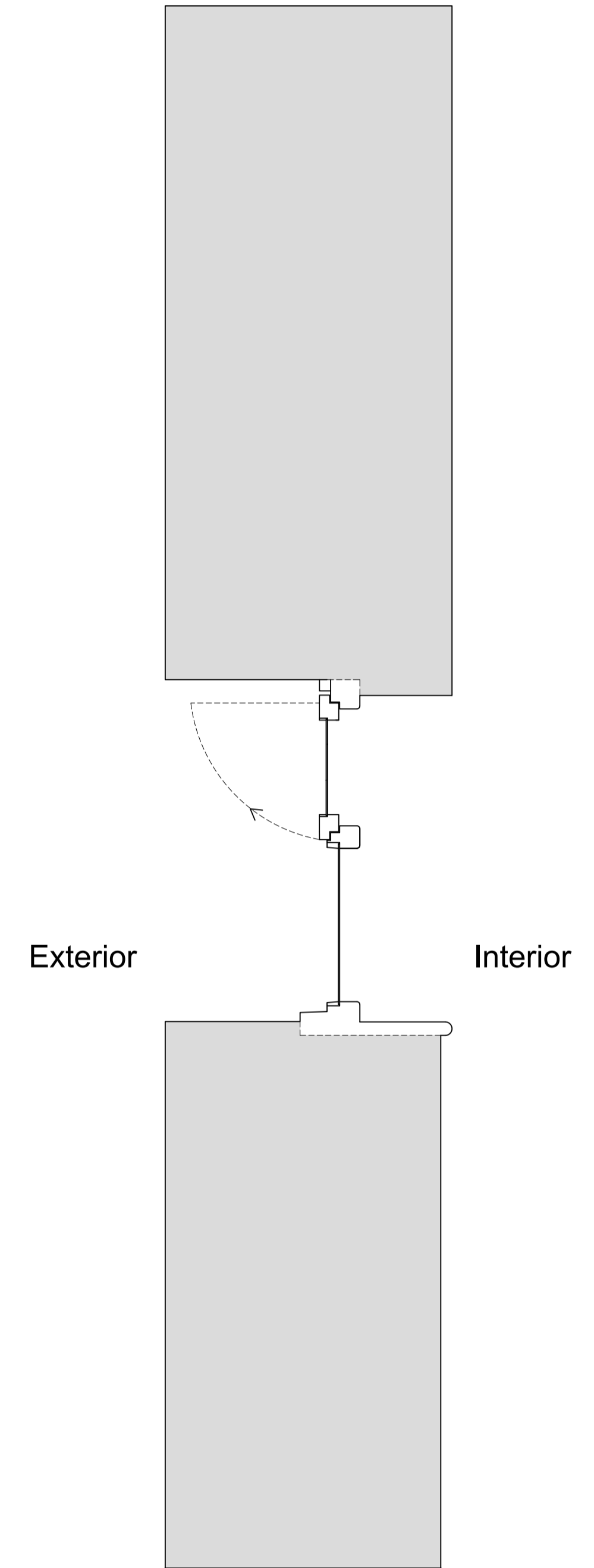

Plan Section B-B
Scale: 1:10

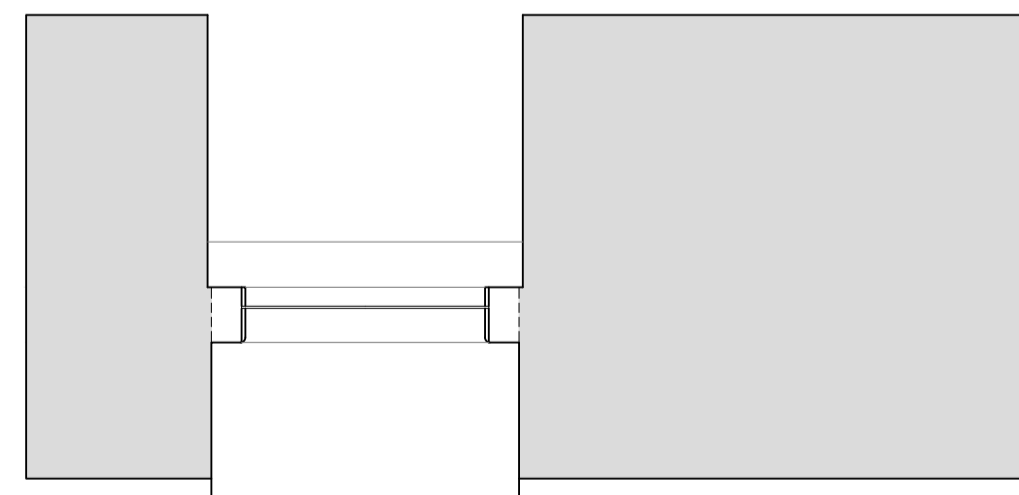

Revision	Date	Assessment
1.0	24-10-2019	Issued for listed building consent application

Do not reproduce this drawing without written permission
All dimensions are in millimetres unless stated otherwise

Drawing Not For Construction

HS2

High Speed (HS2) Limited
1st-3rd Floor
The Podium
1 Eversholt Street
London NW1 2DN

COSTAIN SKANSKA

Costain Skanska Joint Venture
2nd Floor
Addison Lee Compound
Granby Terrace
London NW1 3SA

Site Address:
1 Mornington Crescent, Flat 4, London NW1

Drawing Title:
Second Floor - Landing: EXISTING Window Joinery Details -
Sheet 1 of 3

Drawn by: AP & PB
Checked by: OB
Presentation Scale: as shown @ A1

Date: 18-10-2019
Drawing No: WPI P066 NI - 1 MC 4-EX-SF-J-02
Revision: 1.0

Internal Room Elevation with Secondary Glazing Installed

Scale: 1:10

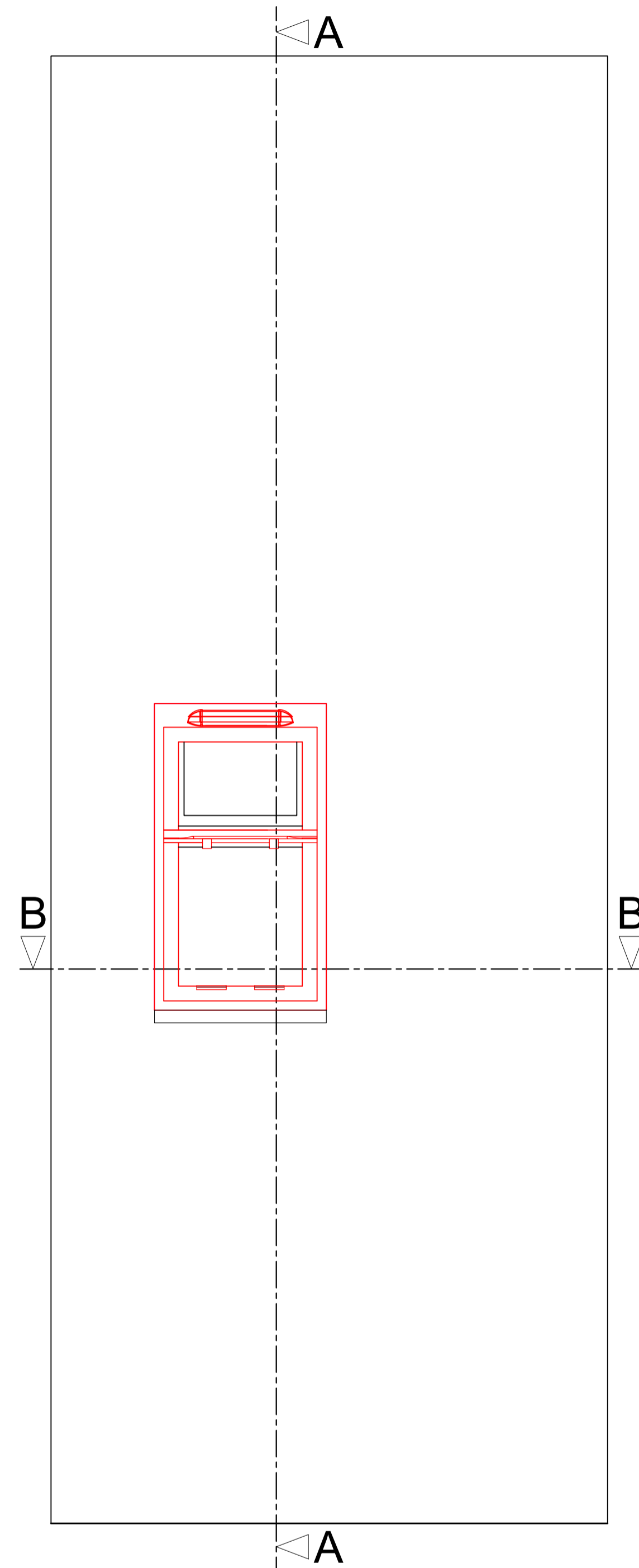

Section A-A through External Wall with Secondary Glazing Installed

Scale: 1:10

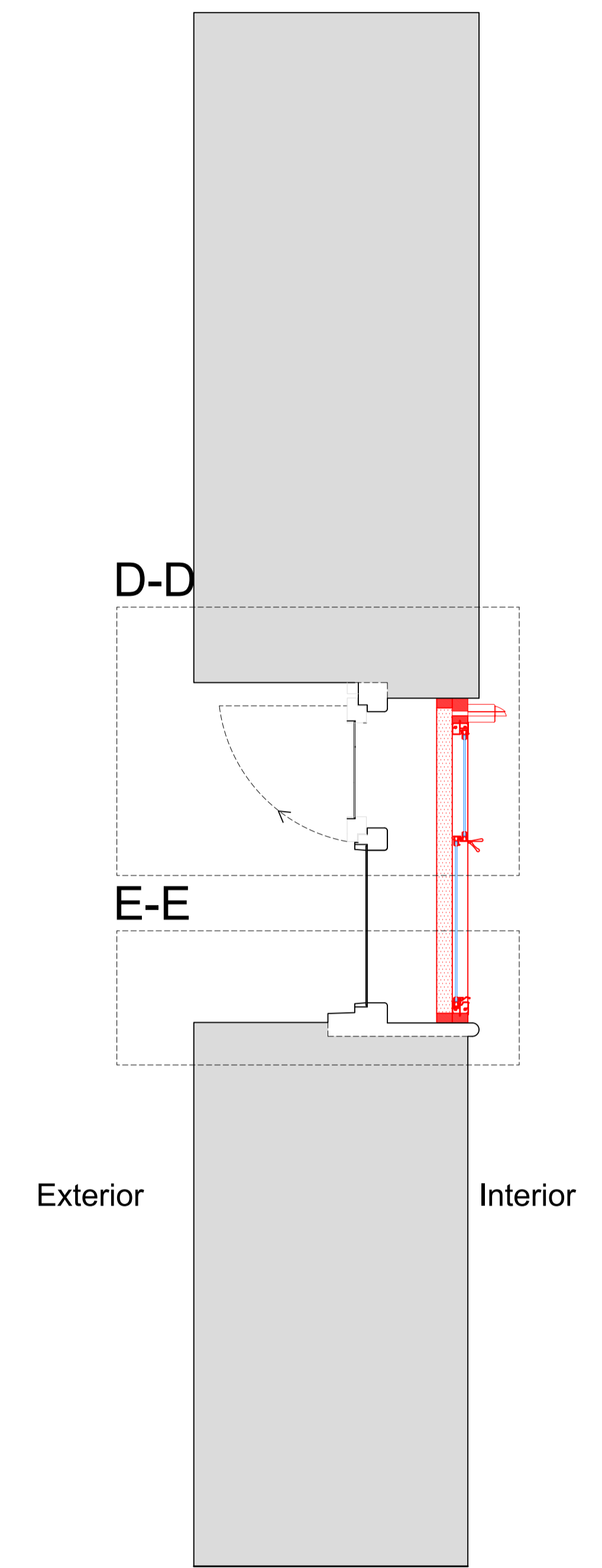

SECONDARY GLAZING SHOWN IN RED FOR VISUAL CLARITY ONLY

Plan Section B-B with Secondary Glazing Installed

Scale: 1:10

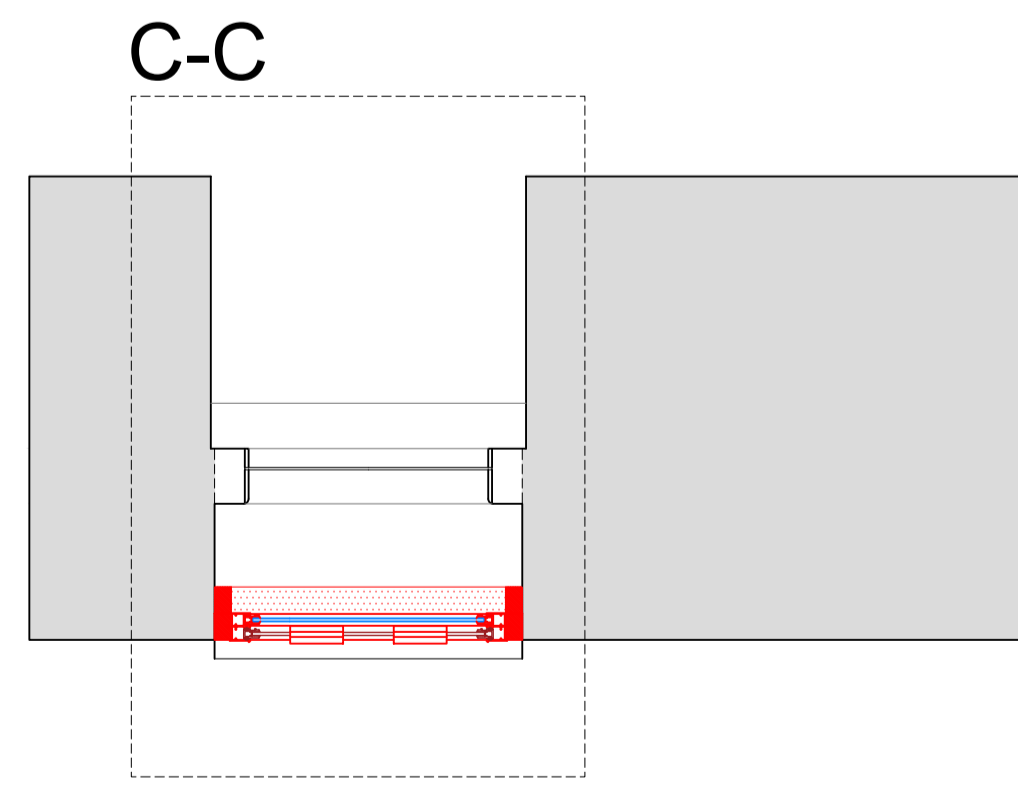

Revision	Date	Assessment
1.0	24-10-2019	Issued for listed building consent application

Do not reproduce this drawing without written permission
All dimensions are in millimetres unless stated otherwise

Drawing Not For Construction

HS2

High Speed (HS2) Limited
1st-3rd Floor
The Podium
1 Eversholt Street
London NW1 2DN

COSTAIN SKANSKA

Costain Skanska Joint Venture
2nd Floor
Addison Lee Compound
Granby Terrace
London NW1 3SA

Site Address: 1 Mornington Crescent, Flat 4, London NW1			
Drawing Title: Second Floor - Landing: PROPOSED Secondary Glazing Details - Sheet 2 of 3			
Drawn by: AP & PB	Checked by: PB	Presented by: OB	Scale: as shown @ A1
Date: 18-10-2019	Drawing No: WPI P066 NI - 1 MC 4-PR-SF-J-02.1	Revision: 1.0	

Section C-C
Scale: 1:5 on A1

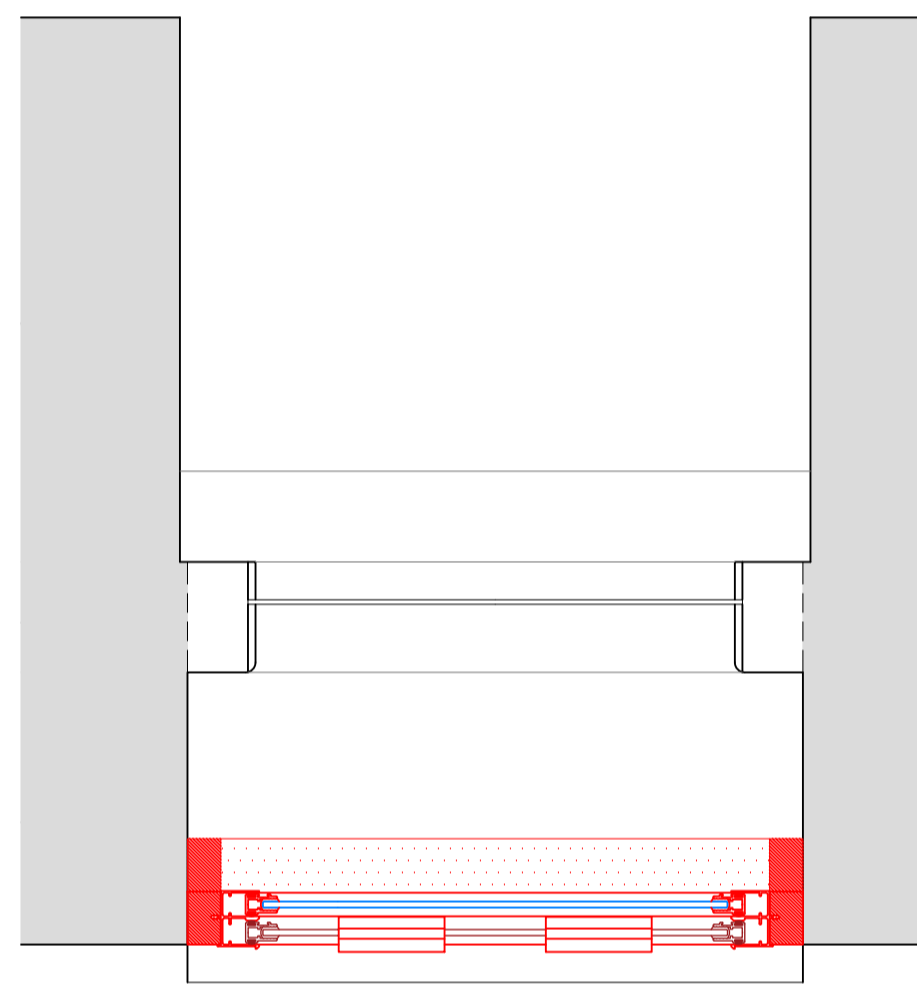

Section E-E
Scale: 1:5 on A1

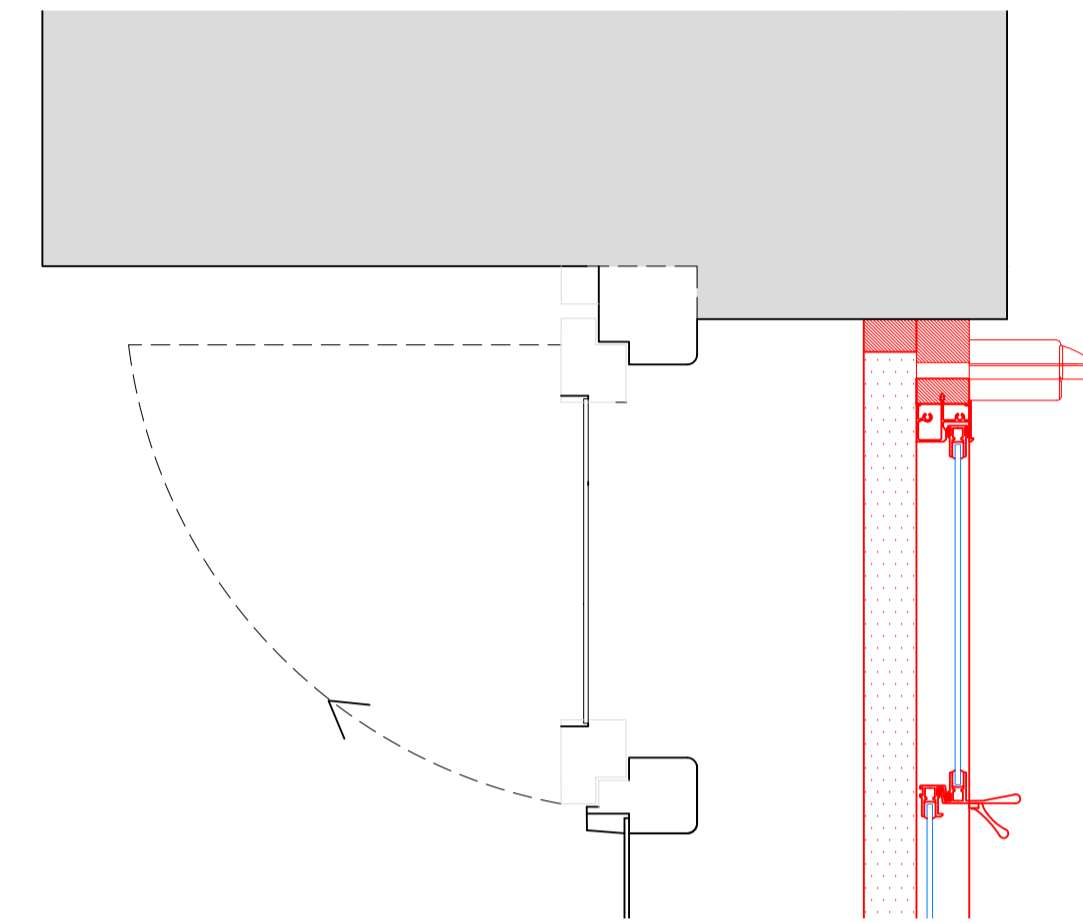

Section D-D
Scale: 1:5 on A1

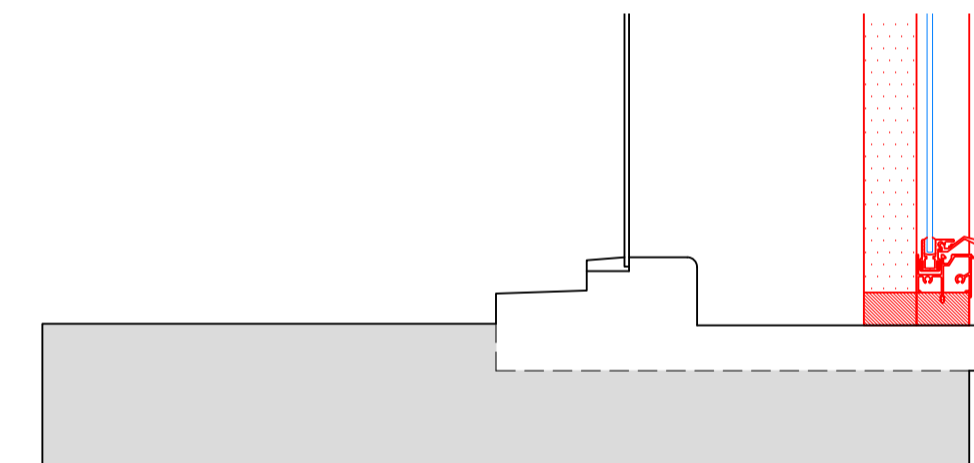

SECONDARY GLAZING SHOWN IN RED FOR VISUAL CLARITY ONLY

Revision	Date	Assessment
1.0	24-10-2019	Issued for listed building consent application

Do not reproduce this drawing without written permission
All dimensions are in millimetres unless stated otherwise

Drawing Not For Construction

HS2

High Speed (HS2) Limited
1st-3rd Floor
The Podium
1 Eversholt Street
London NW1 2DN

COSTAIN SKANSKA

Costain Skanska Joint Venture
2nd Floor
Addison Lee Compound
Granby Terrace
London NW1 3SA

Site Address: 1 Mornington Crescent, Flat 4, London NW1			
Drawing Title: Second Floor - Landing: PROPOSED Secondary Glazing Details - Sheet 3 of 3			
Drawn by: AP & PB	Checked by: PB	Reviewed by: OB	Presentation Scale: 1:5 @ A1
Date: 18-10-2019	Drawing No: WPI P066 NI - 1 MC 4-PR-SF-J-02.2	Revision: 1.0	

Internal Room Elevation

Scale: 1:10

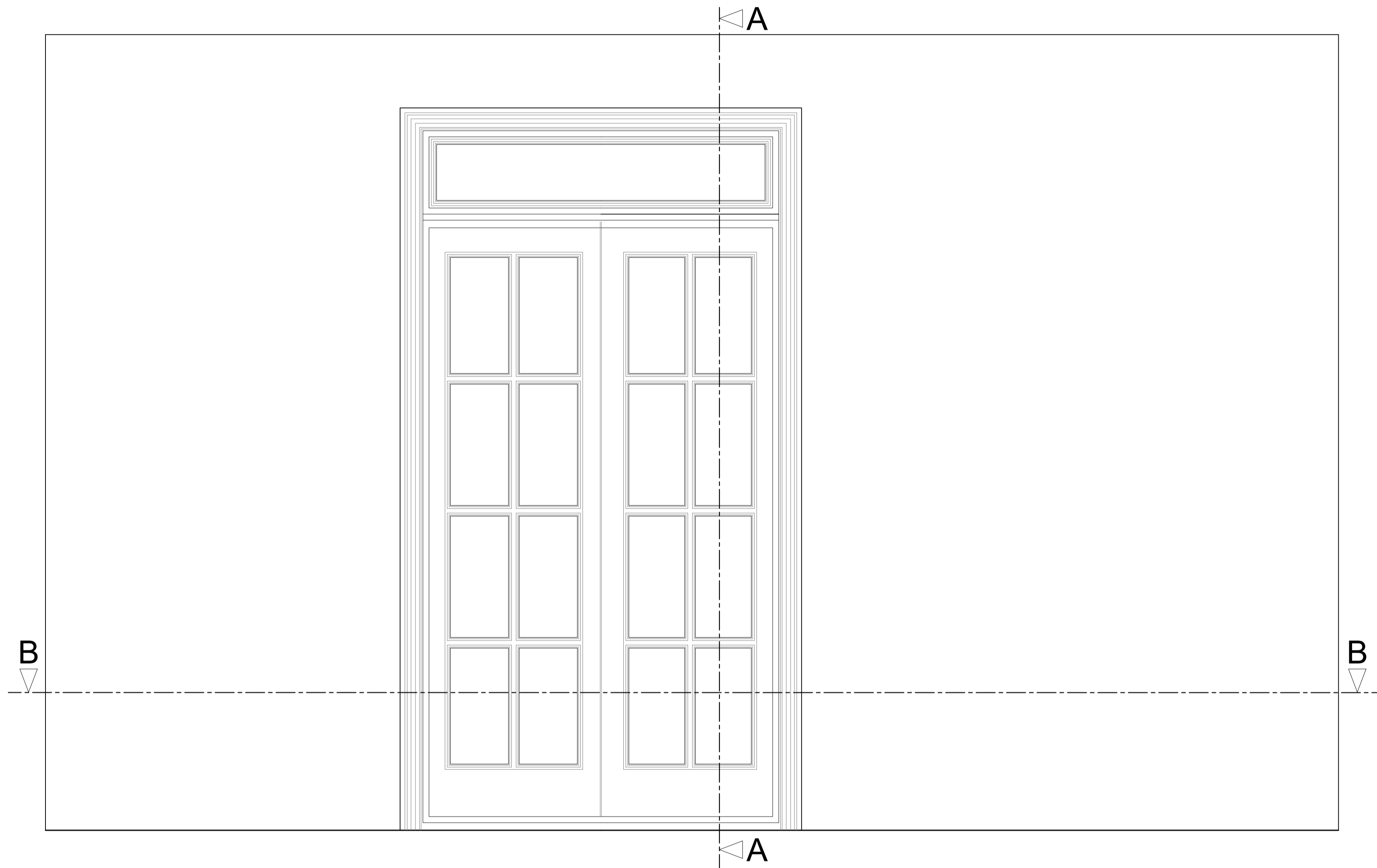

Section A-A through External Wall

Scale: 1:10

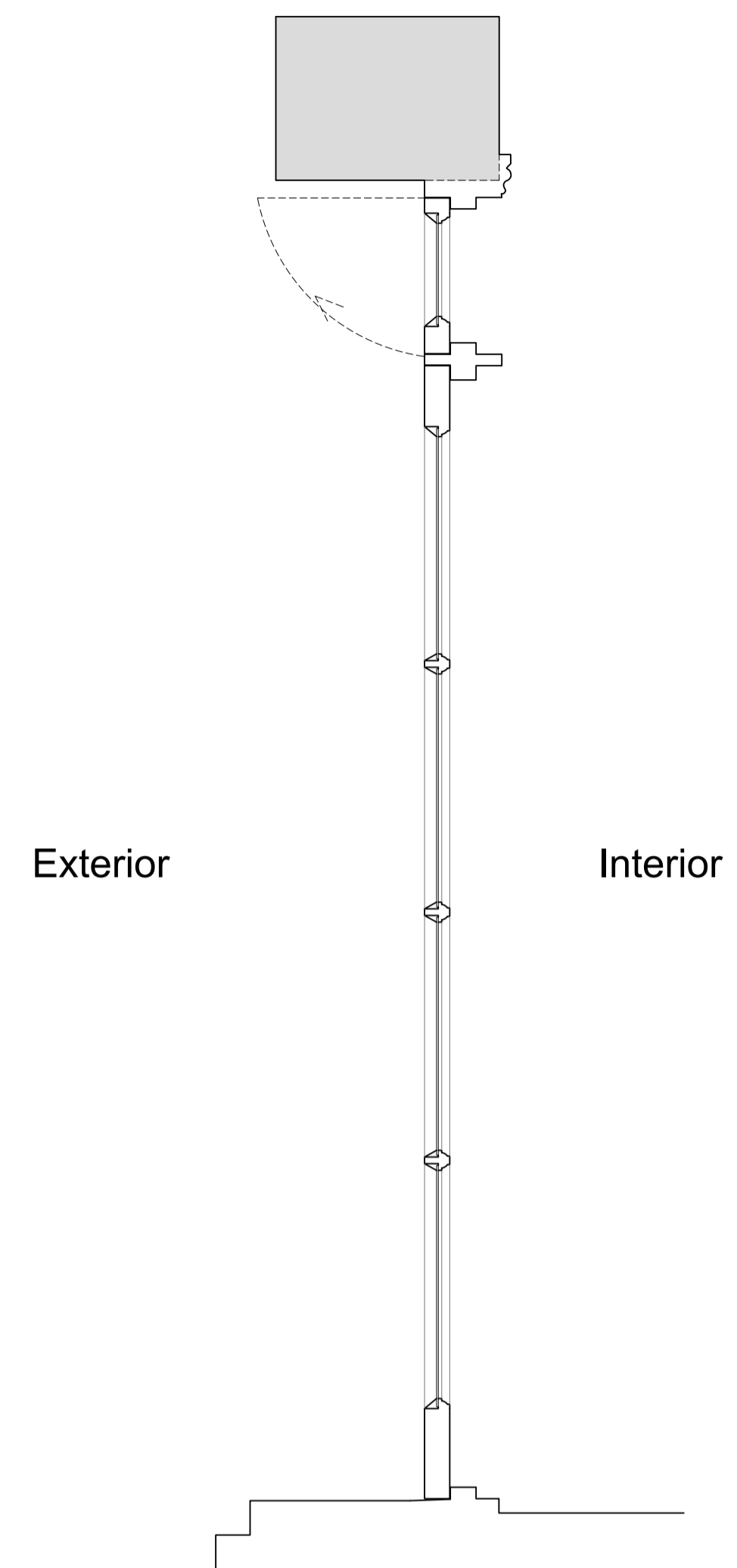

Plan Section B-B

Scale: 1:10

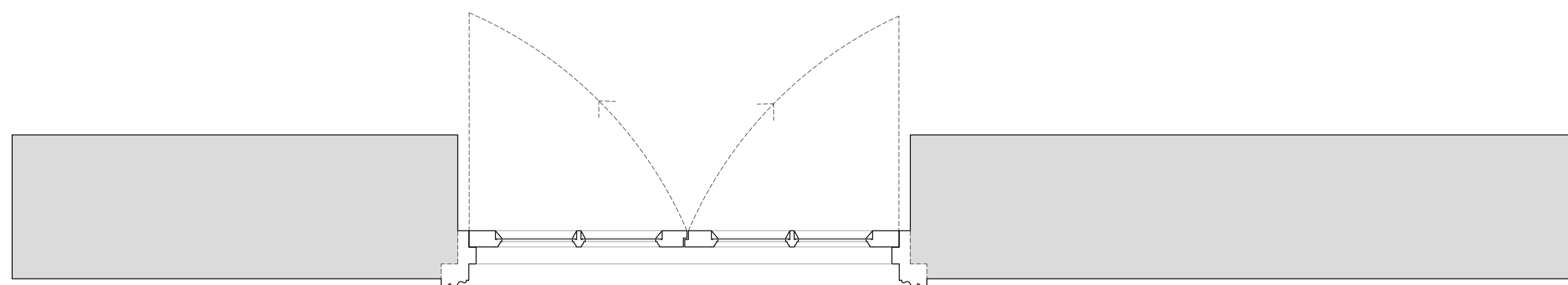

Revision	Date	Amendment
1.0	24-10-2019	Issued for listed building consent application

Do not reproduce this drawing without written permission
All dimensions are in millimetres unless stated otherwise

Drawing Not For Construction

HS2

High Speed (HS2) Limited
1st-3rd Floor
The Podium
1 Eversholt Street
London NW1 2DN

COSTAIN SKANSKA

Costain Skanska Joint Venture
2nd Floor
Addison Lee Compound
Granby Terrace
London NW1 3SA

Site Address:
1 Mornington Crescent, Flat 4, London NW1

Drawing Title:
Second Floor - Lounge: EXISTING Window Joinery Details -
Sheet 1 of 3

Drawn by: AP & PB
Checked by: OB
Presentation Scale: as shown @ A1

Date: 18-10-2019
Drawing No: WPI P066 NI - 1 MC 4-EX-SF-J-02
Revision: 1.0

Internal Room Elevation with Secondary Glazing Installed

Scale: 1:10

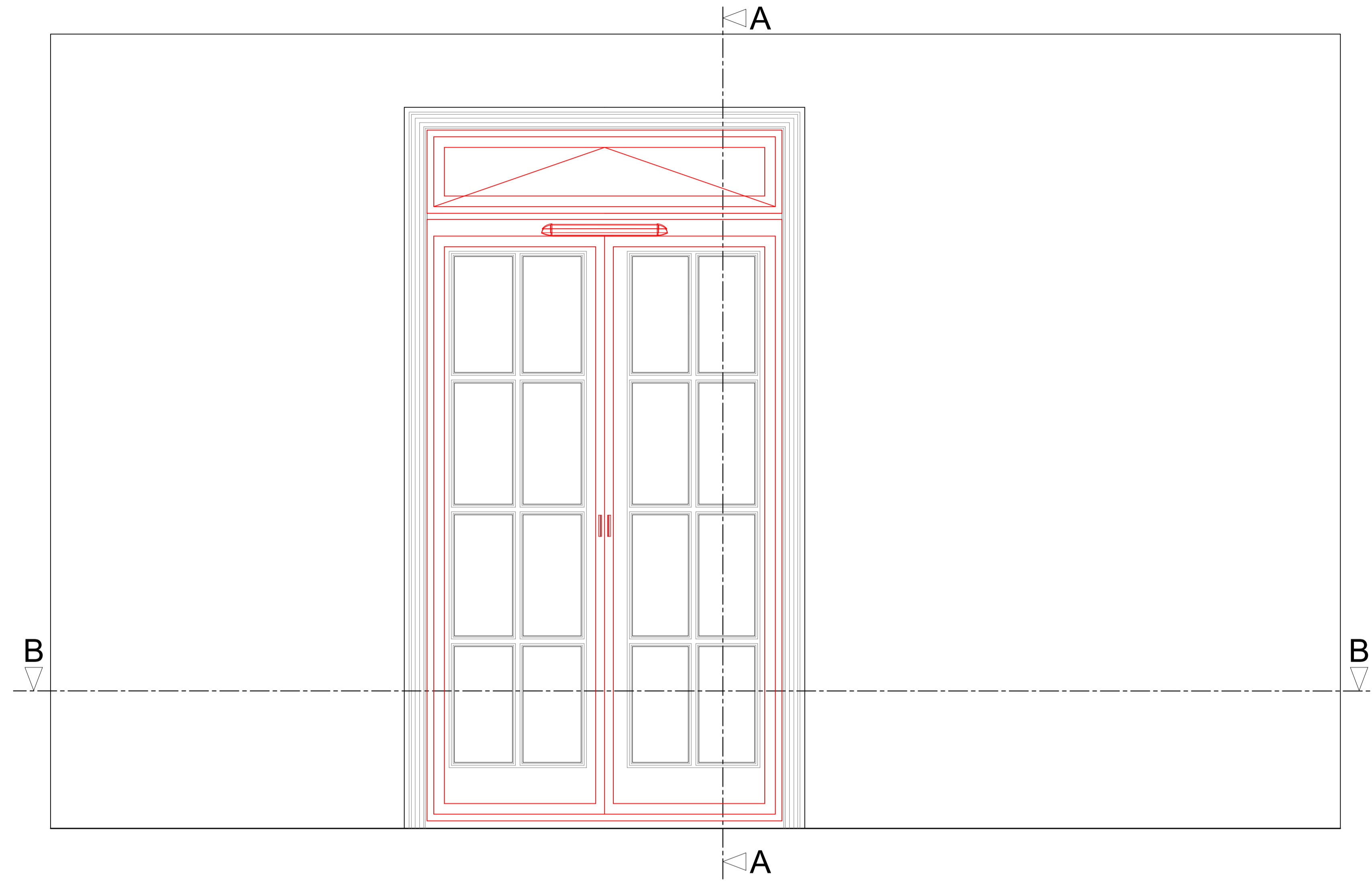

Section A-A through External Wall with Secondary Glazing Installed

Scale: 1:10

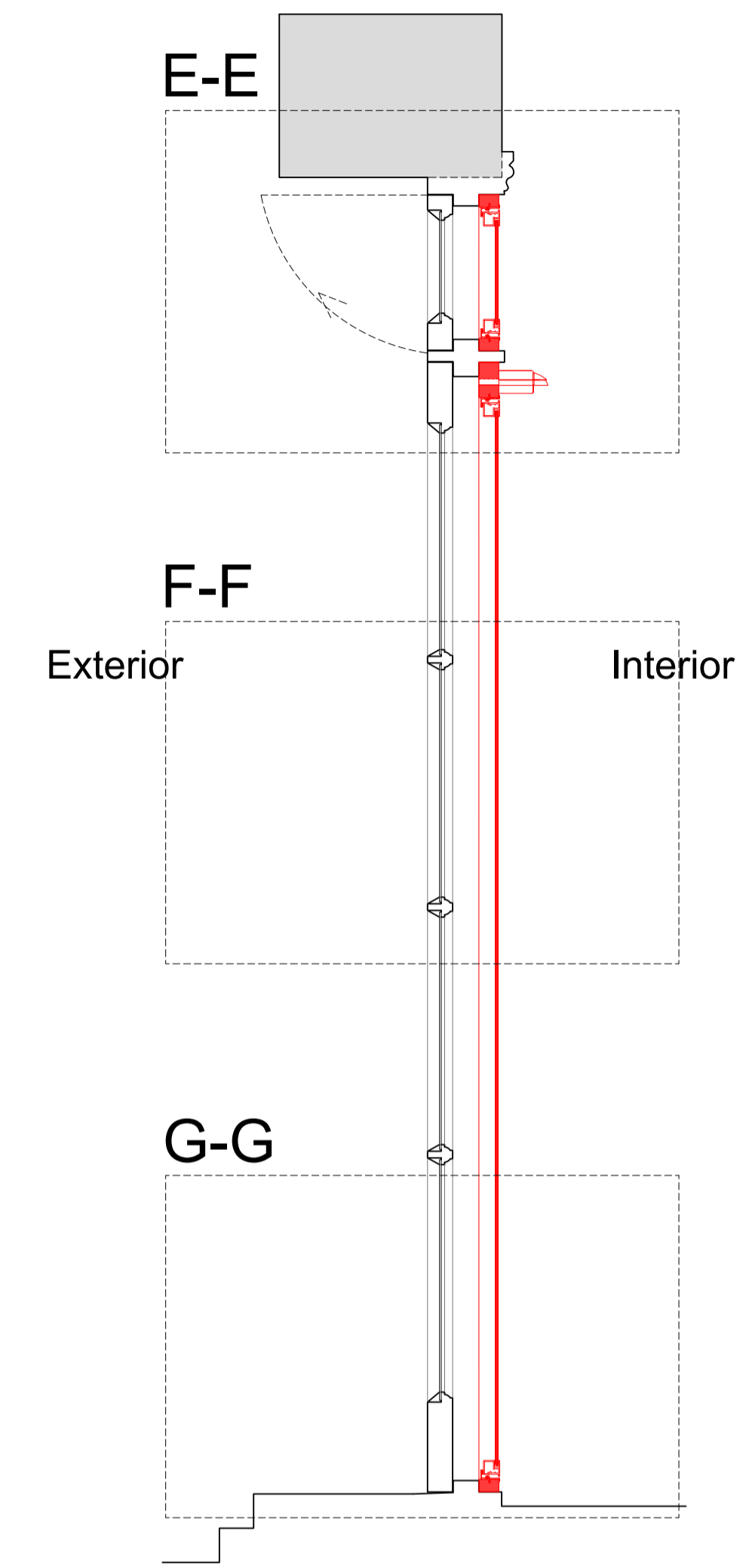

Plan Section B-B with Secondary Glazing Installed

Scale: 1:10

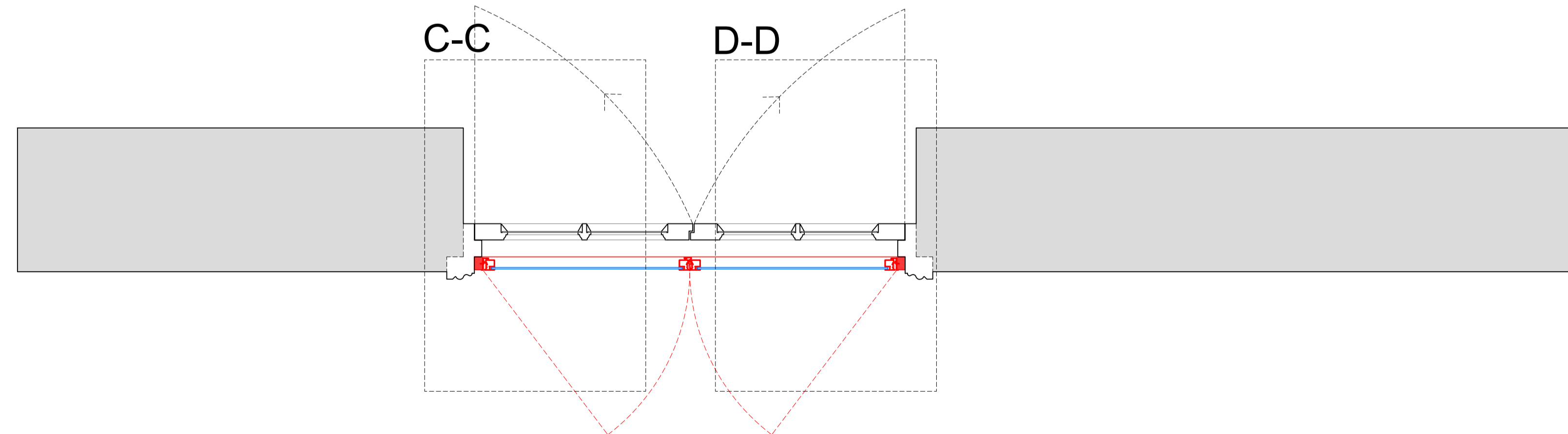

SECONDARY GLAZING SHOWN IN RED FOR VISUAL CLARITY ONLY

Revision	Date	Amendment
1.0	24-10-2019	Issued for listed building consent application

Do not reproduce this drawing without written permission
All dimensions are in millimetres unless stated otherwise

Drawing Not For Construction

HS2

High Speed (HS2) Limited
1st-3rd Floor
The Podium
1 Eversholt Street
London NW1 2DN

COSTAIN SKANSKA

Costain Skanska Joint Venture
2nd Floor
Addison Lee Compound
Granby Terrace
London NW1 3SA

Site Address:
1 Mornington Crescent, Flat 4, London NW1

Drawing Title:
Second Floor - Lounge: PROPOSED Secondary Glazing Details -
Sheet 2 of 3

Drawn by: AP & PB
Checked by: OB
Presentation Scale: as shown @ A1

Date: 18-10-2019
Drawing No: WPI P066 NI - 1 MC 4-PR-SF-J-02.1
Revision: 1.0

Section C-C
Scale: 1:5 on A1

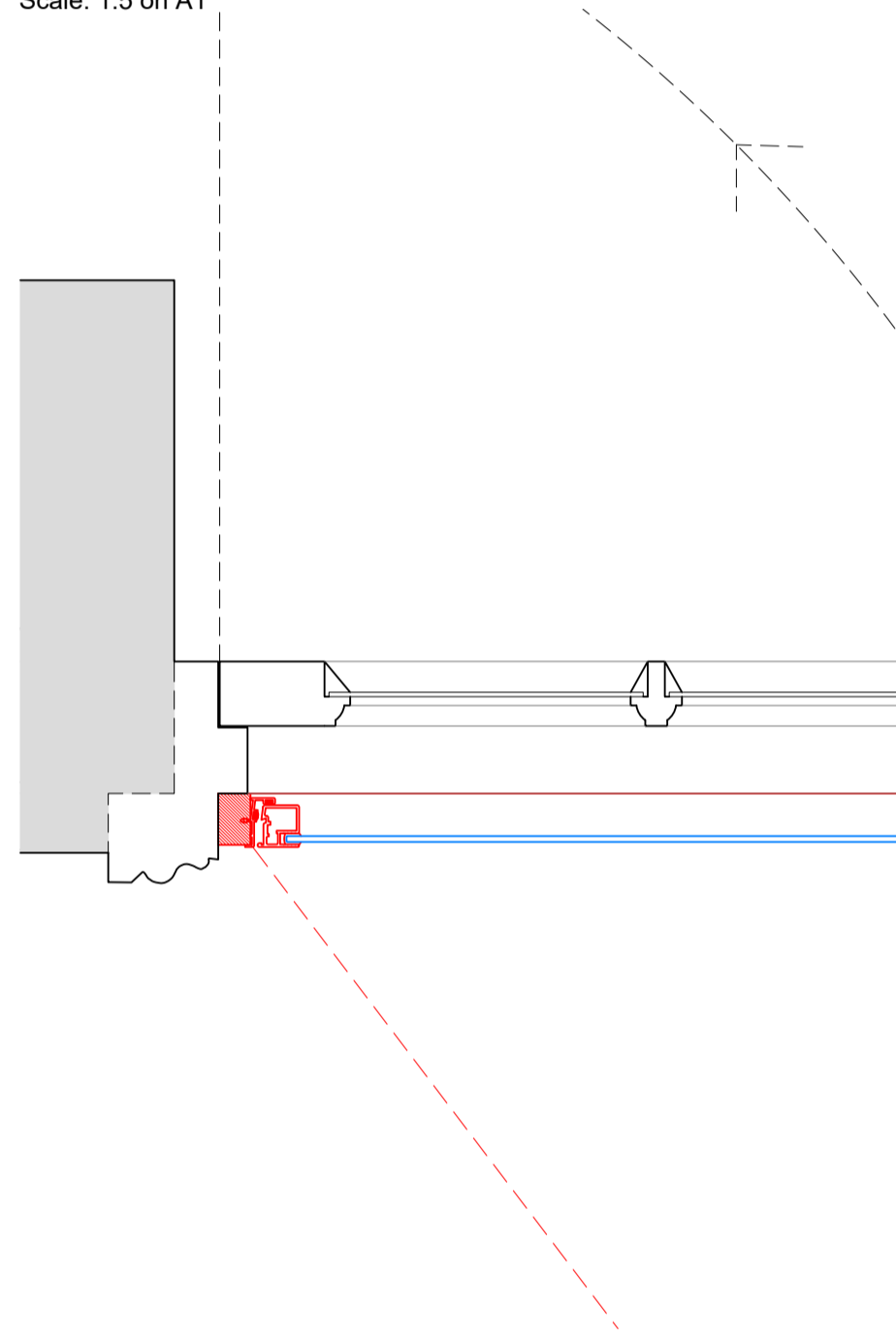

Section D-D
Scale: 1:5 on A1

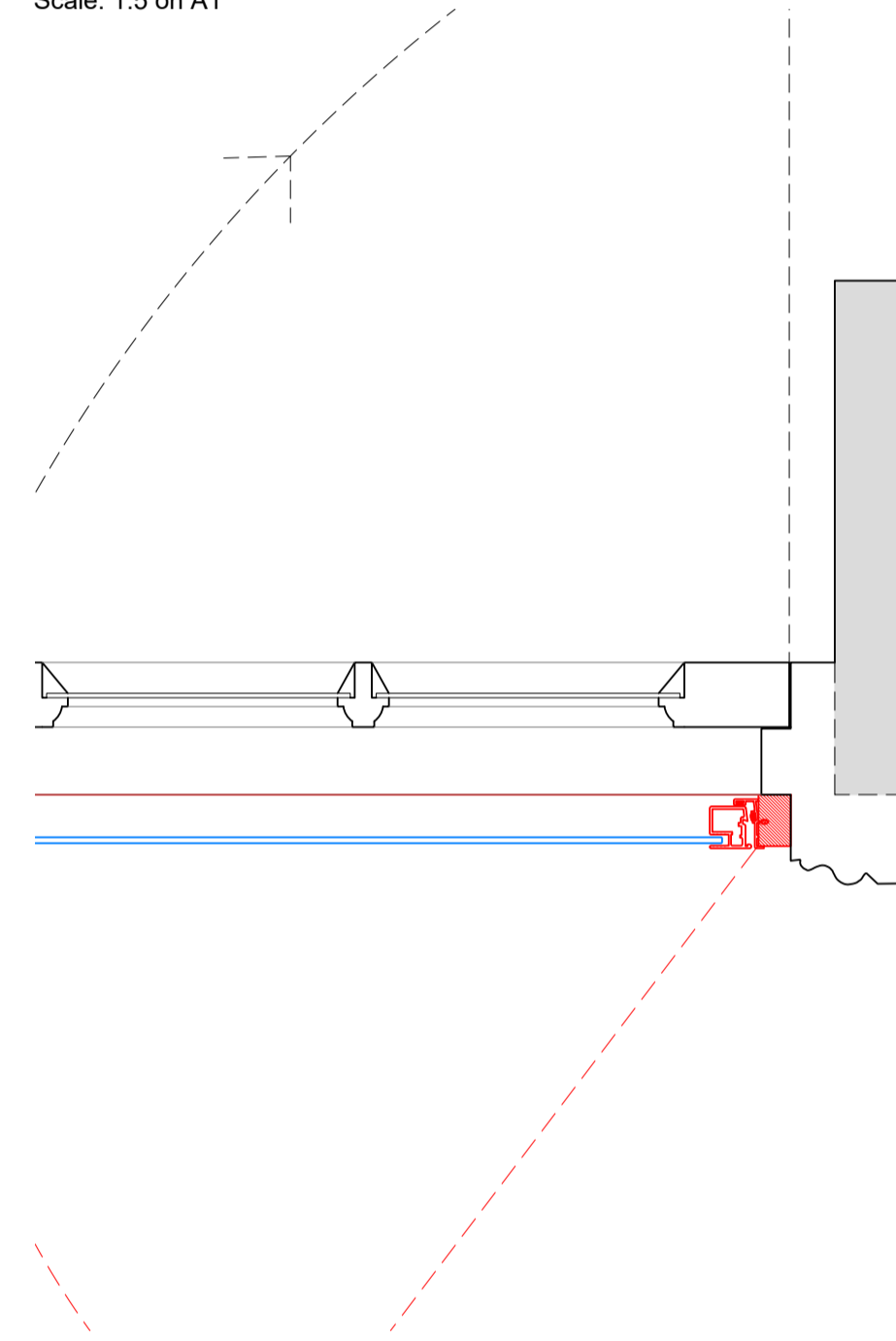

Section E-E
Scale: 1:5 on A1

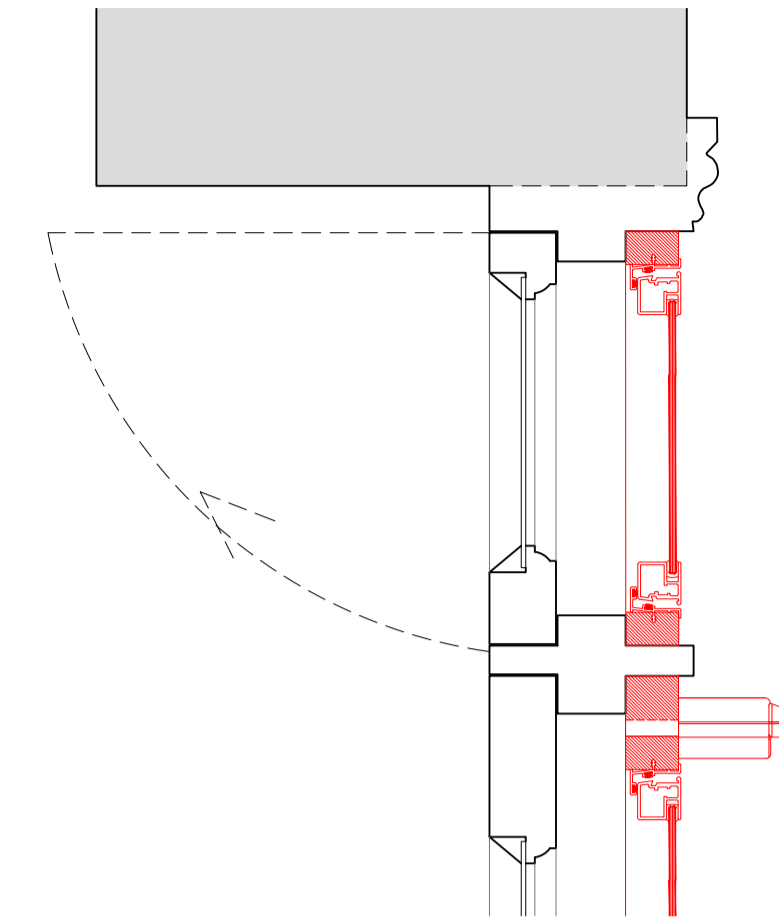

Section F-F
Scale: 1:5 on A1

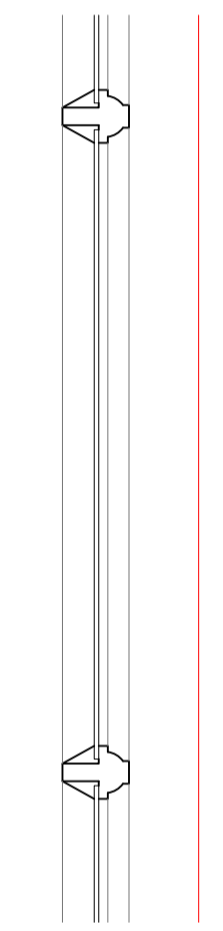

Section G-G
Scale: 1:5 on A1

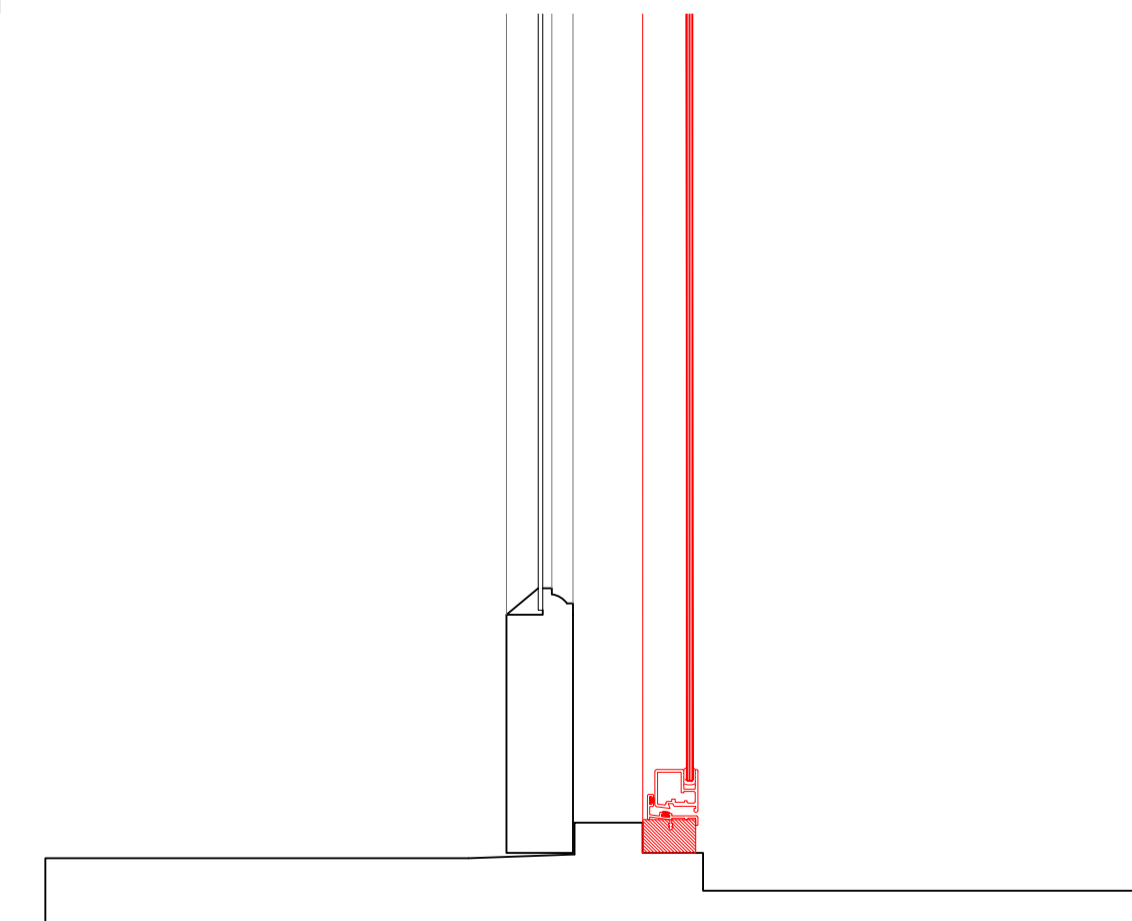

SECONDARY GLAZING SHOWN IN RED FOR VISUAL CLARITY ONLY

Revision	Date	Assessment
1.0	24-10-2019	Issued for listed building consent application

Do not reproduce this drawing without written permission
All dimensions are in millimetres unless stated otherwise

Drawing Not For Construction

HS2

High Speed (HS2) Limited
1st-3rd Floor
The Podium
1 Eversholt Street
London NW1 2DN

COSTAIN SKANSKA

Costain Skanska Joint Venture
2nd Floor
Addison Lee Compound
Granby Terrace
London NW1 3SA

Site Address: 1 Mornington Crescent, Flat 4, London NW1			
Drawing Title: Second Floor - Lounge: PROPOSED Secondary Glazing Details - Sheet 3 of 3			
Drawn by: AP & PB	Checked by: PB	Presented by: OB	Scale: 1:5 @ A1
Date: 18-10-2019	Drawing No: WPI P066 NI - 1 MC 4-PR-SF-J-02.2	Revision: 1.0	

Internal Room Elevation
Scale: 1:10

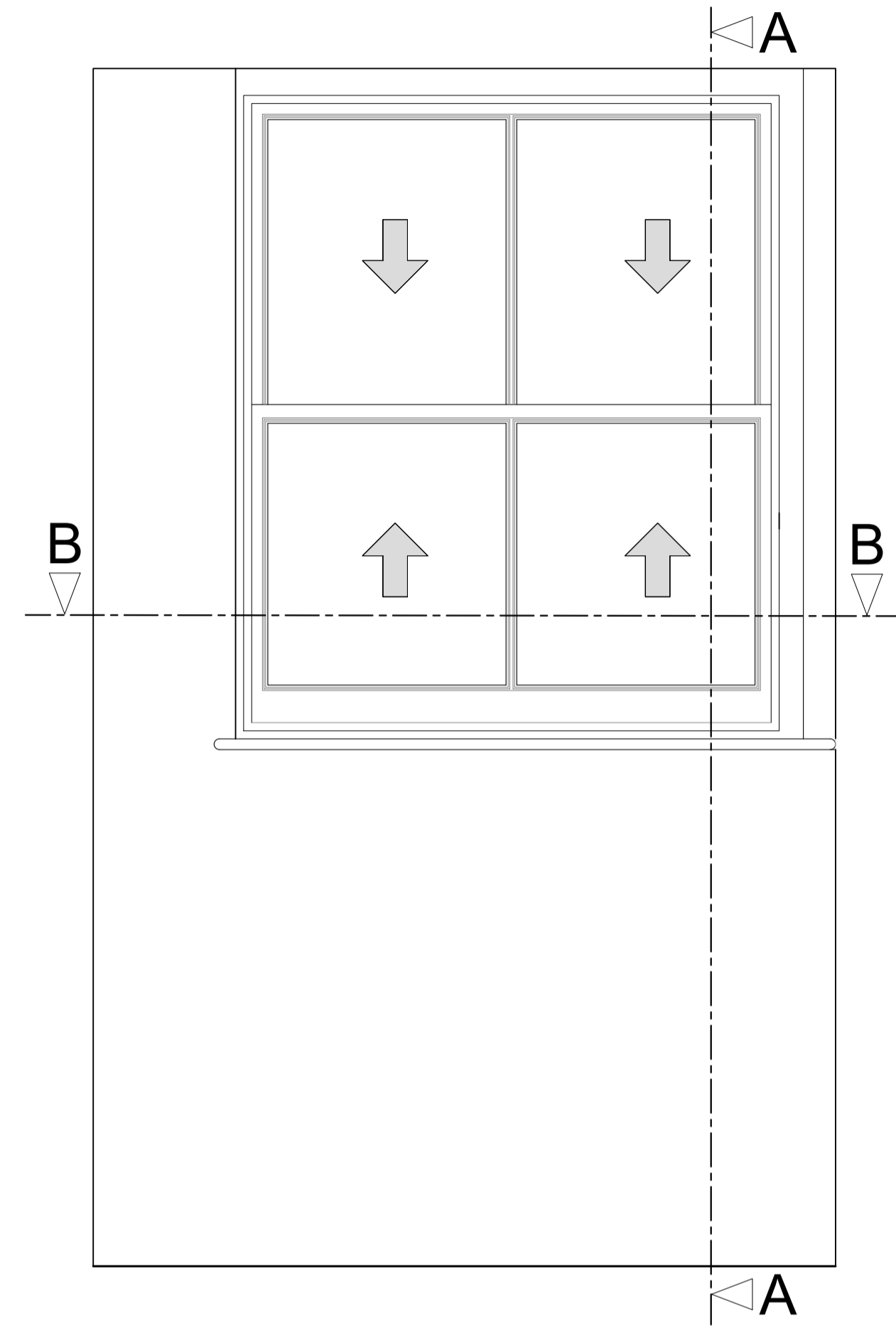

Section A-A through External Wall
Scale: 1:10

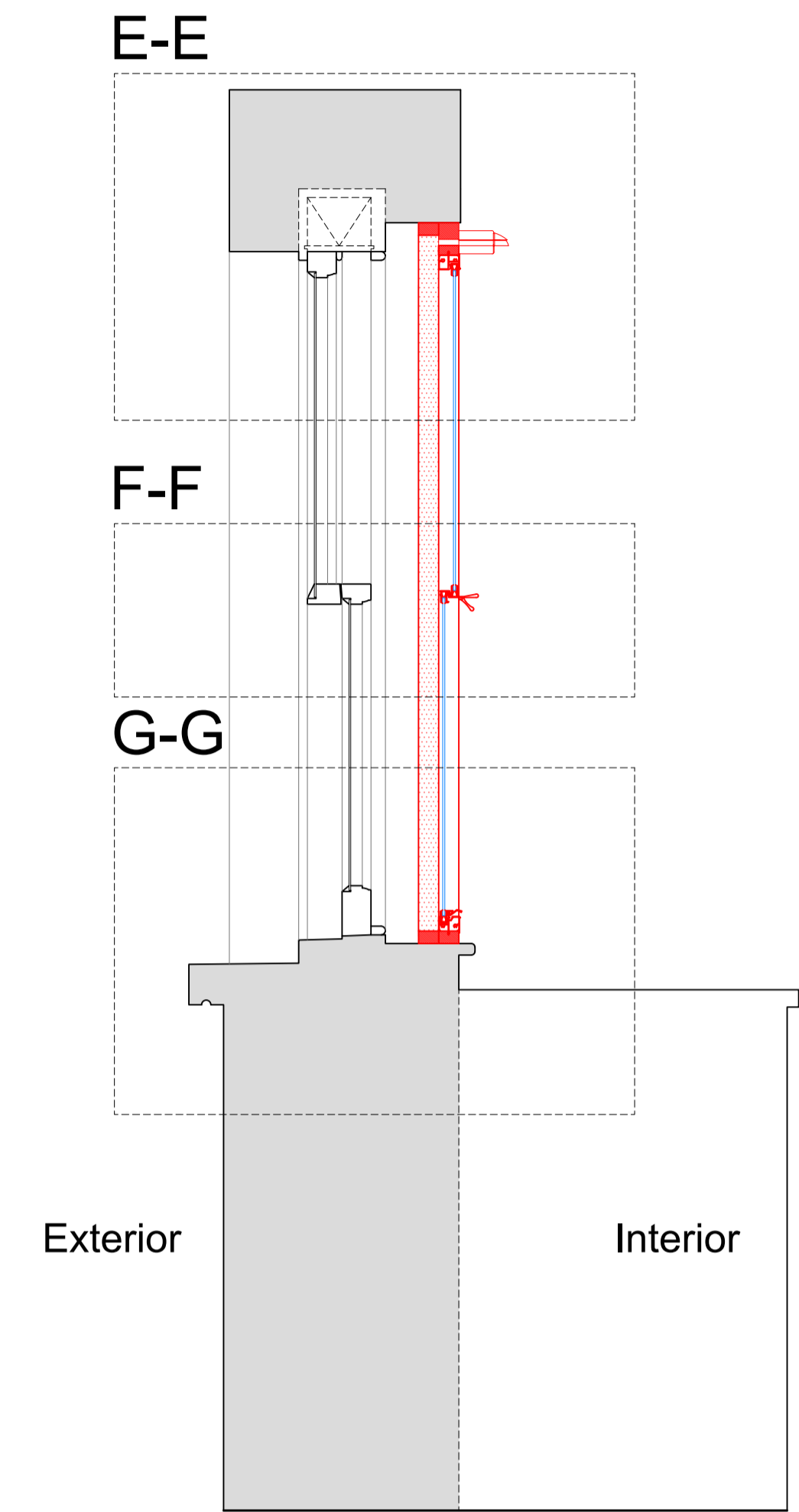

Plan Section B-B
Scale: 1:10

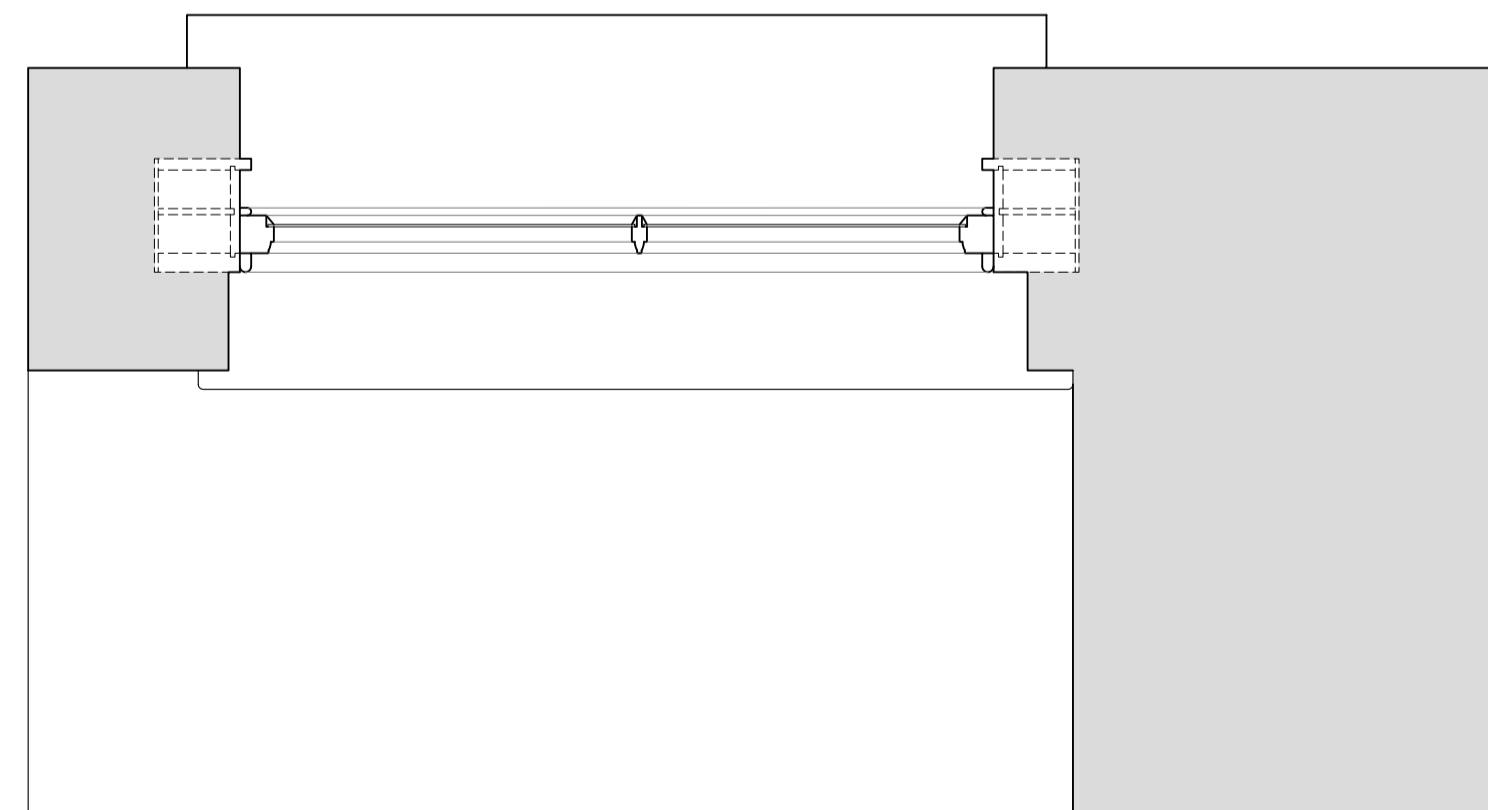

Revision	Date	Assessment
1.0	24-10-2019	Issued for listed building consent application

Do not reproduce this drawing without written permission
All dimensions are in millimetres unless stated otherwise

Drawing Not For Construction

HS2

High Speed (HS2) Limited
1st-3rd Floor
The Podium
1 Eversholt Street
London NW1 2DN

COSTAIN SKANSKA

Costain Skanska Joint Venture
2nd Floor
Addison Lee Compound
Granby Terrace
London NW1 3SA

Site Address: 1 Mornington Crescent, Flat 4, London NW1			
Drawing Title: Lower Second Floor - Kitchen: EXISTING Window Joinery Details - Sheet 1 of 3			
Drawn by: AP & PB	Drawn by: PB	Checked by: OB	Presentation Scale: as shown @ A1
Date: 18-10-2019	Drawing No: WPI P066 NI - 1 MC 4-EX-LSF-J-02	Revision: 1.0	

Internal Room Elevation with Secondary Glazing Installed

Scale: 1:10

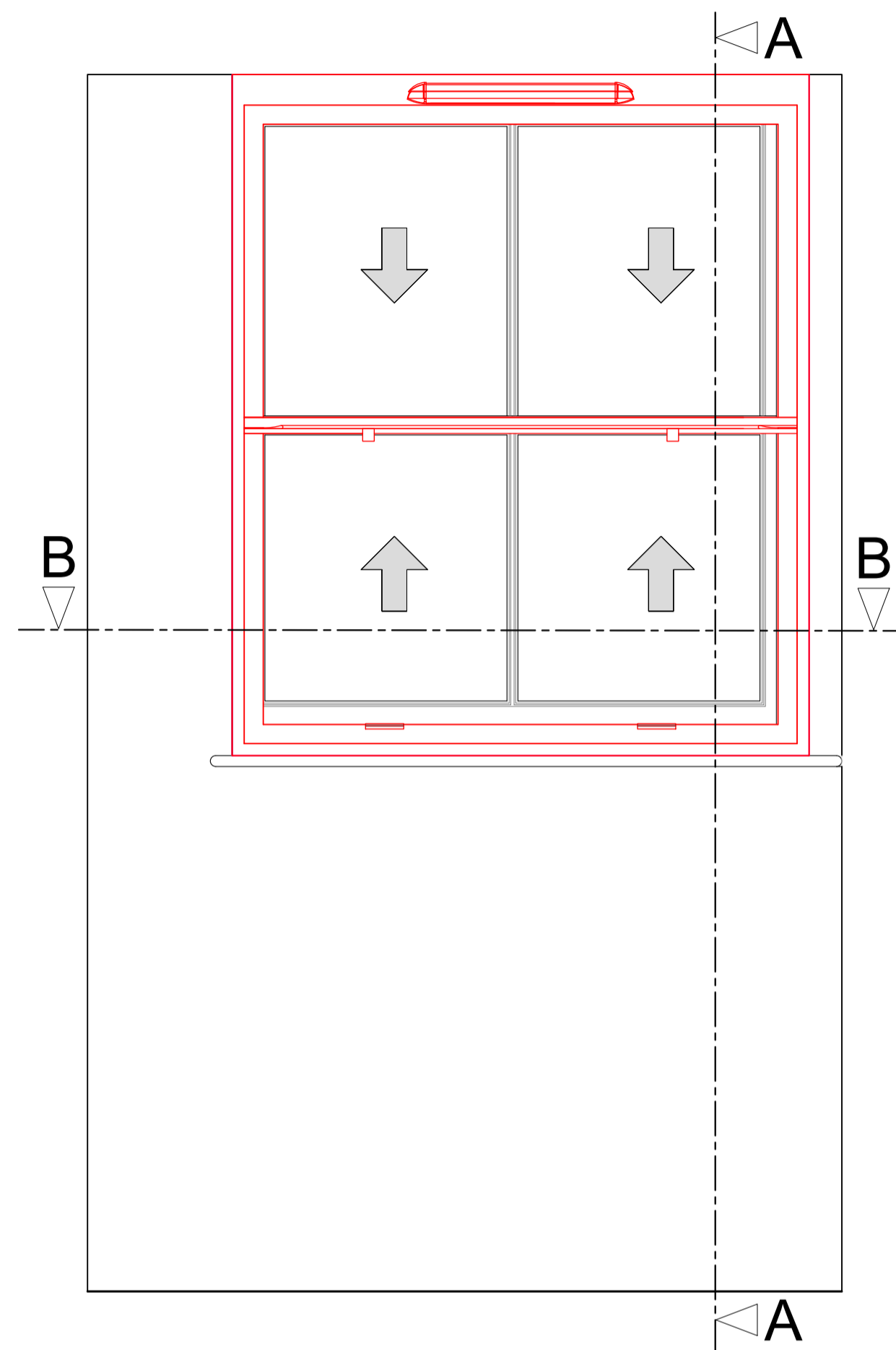

Section A-A through External Wall with Secondary Glazing Installed

Scale: 1:10

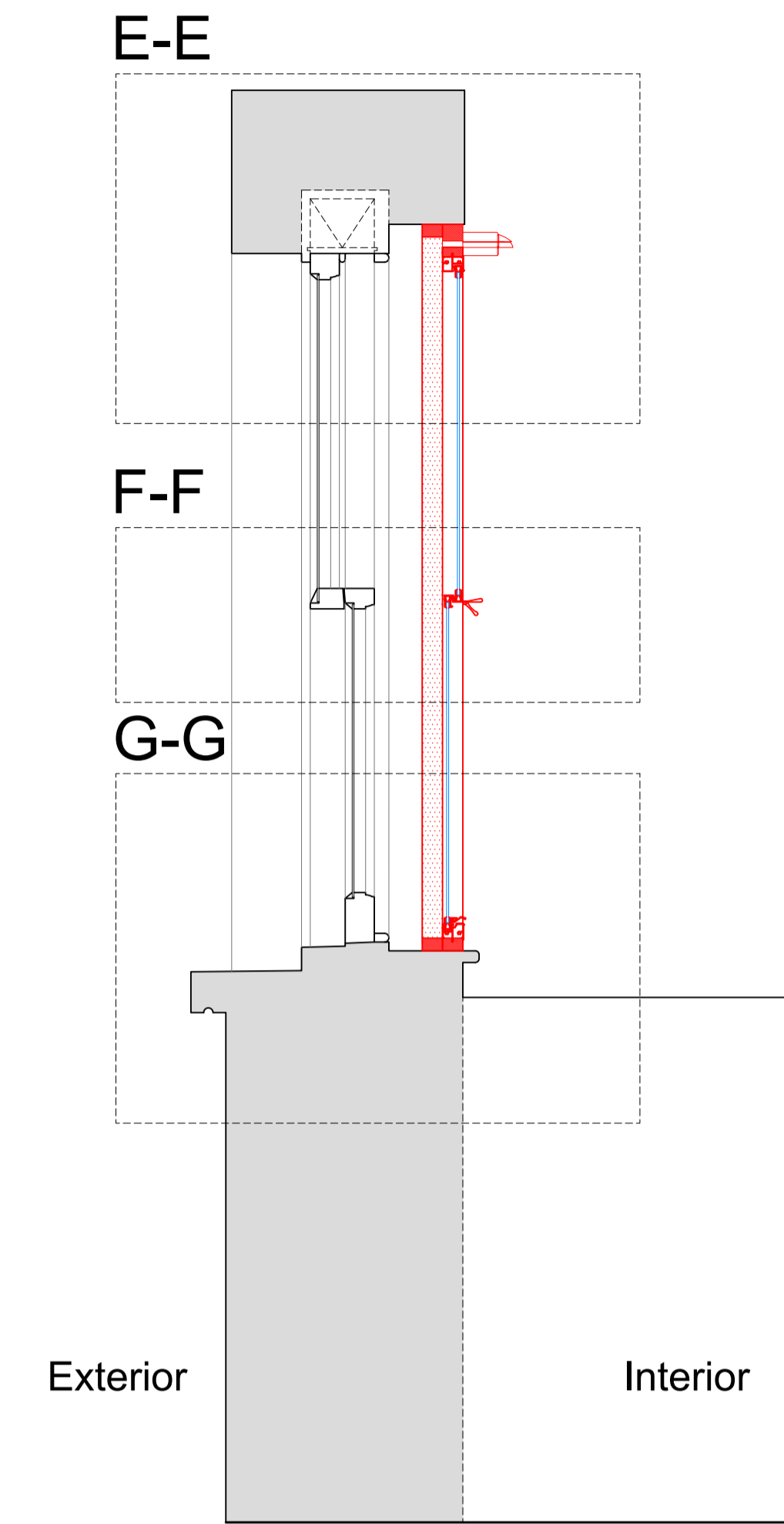

Plan Section B-B with Secondary Glazing Installed

Scale: 1:10

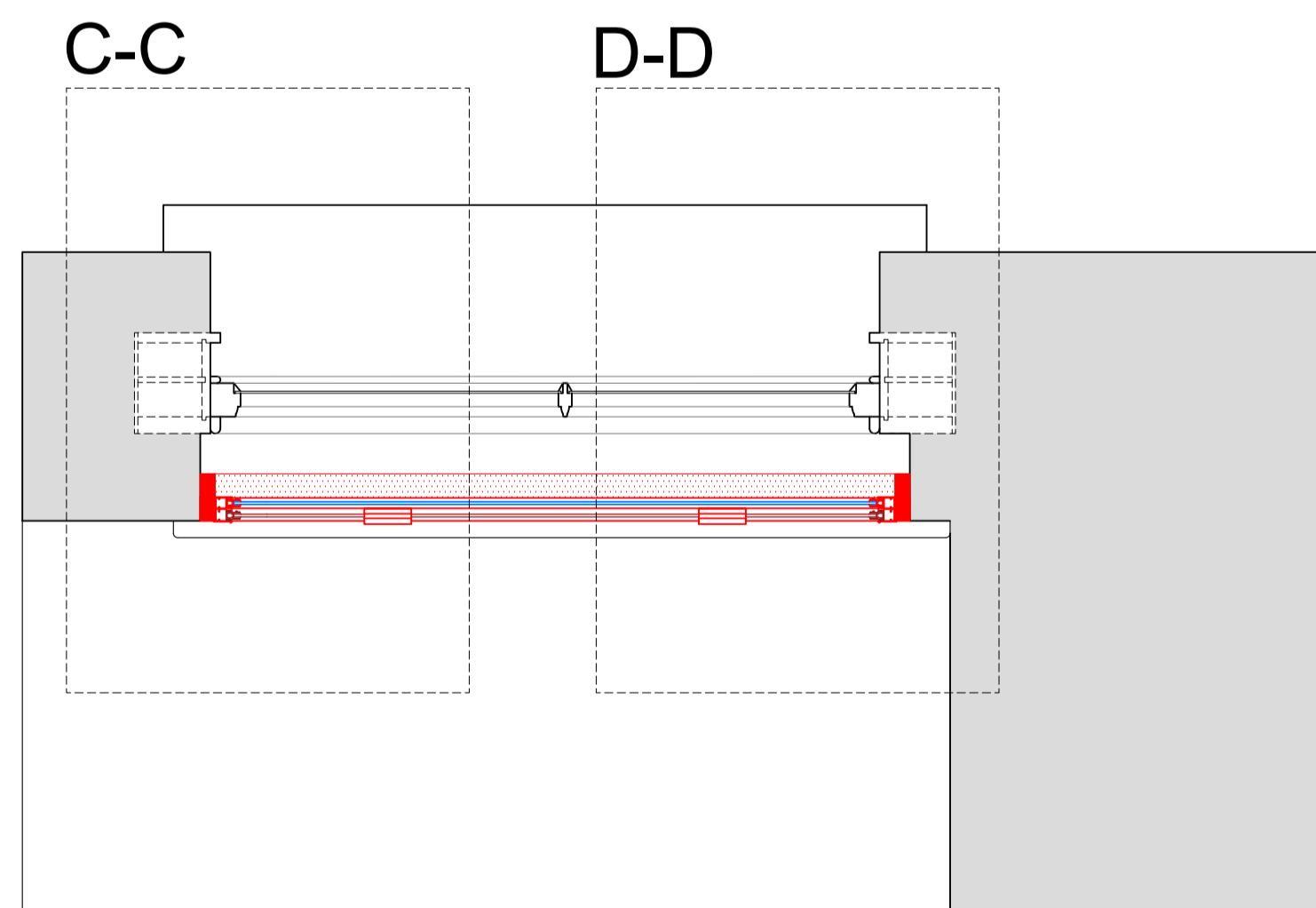

SECONDARY GLAZING SHOWN IN RED FOR VISUAL CLARITY ONLY

Revision	Date	Assessment
1.0	24-10-2019	Issued for listed building consent application

Do not reproduce this drawing without written permission
All dimensions are in millimetres unless stated otherwise

Drawing Not For Construction

HS2

High Speed (HS2) Limited
1st-3rd Floor
The Podium
1 Eversholt Street
London NW1 2DN

COSTAIN SKANSKA

Costain Skanska Joint Venture
2nd Floor
Addison Lee Compound
Granby Terrace
London NW1 3SA

Site Address:
1 Mornington Crescent, Flat 4, London NW1

Drawing Title:
Lower Second Floor - Kitchen: PROPOSED Secondary Glazing Details - Sheet 2 of 3

Drawn by: AP & PB
Checked by: OB
Presentation Scale: as shown @ A1

Date: 18-10-2019
Drawing No: WPI P066 NI - 1 MC 4-PR-LSF-J-02.1
Revision: 1.0

Section C-C
Scale: 1:5 on A1

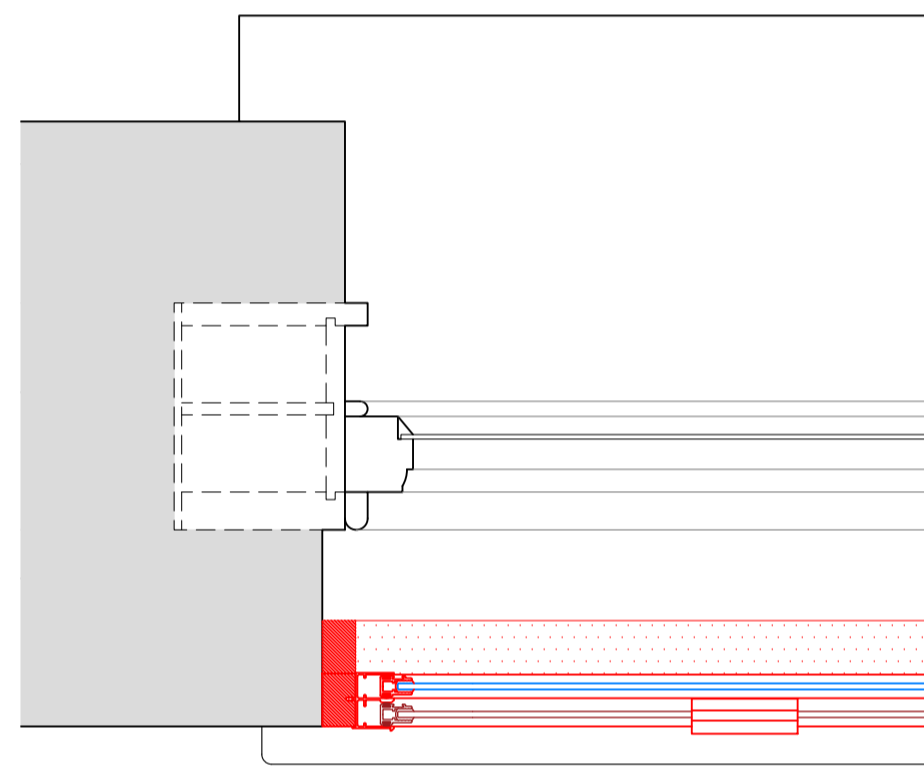

Section D-D
Scale: 1:5 on A1

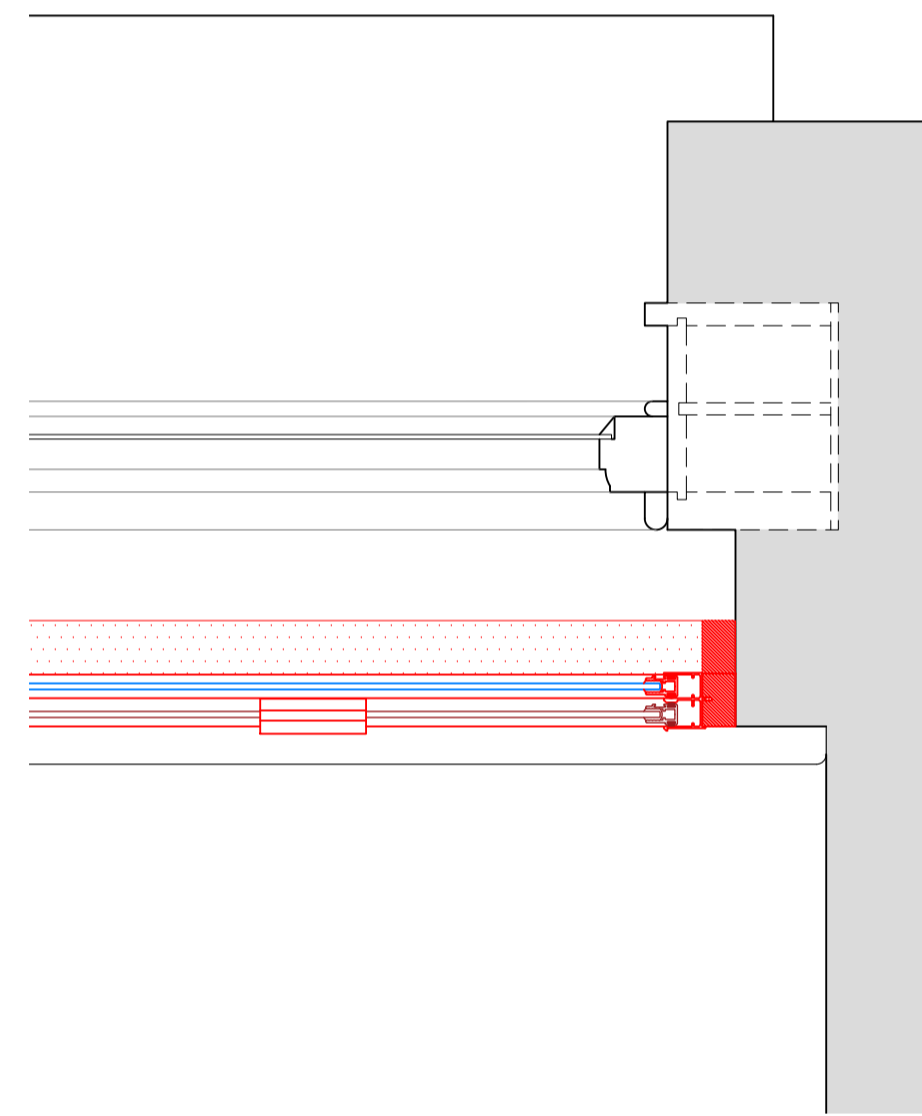

Section E-E
Scale: 1:5 on A1

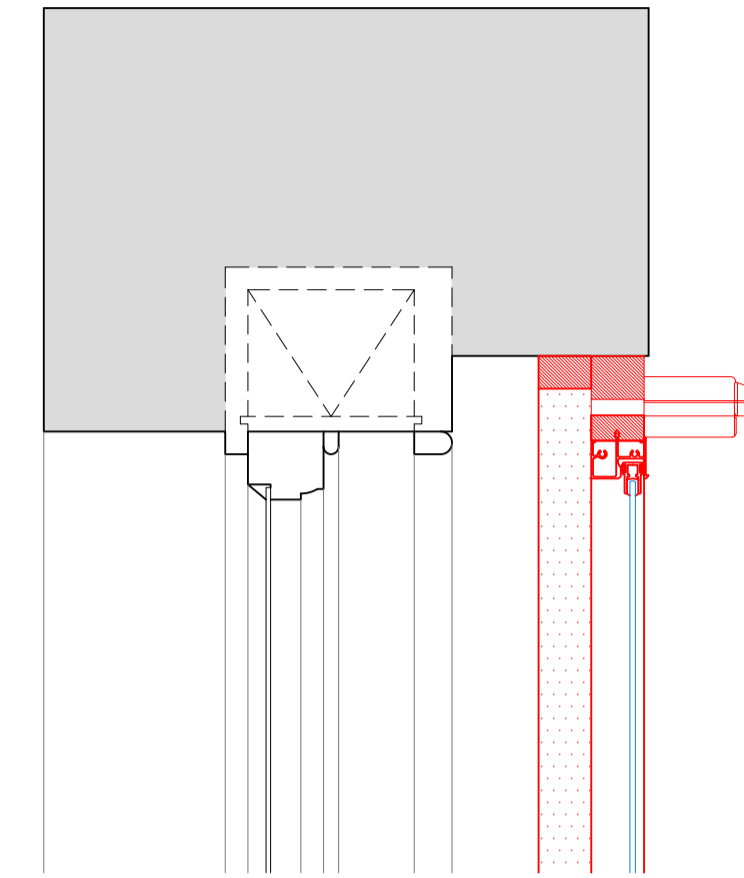

Section F-F
Scale: 1:5 on A1

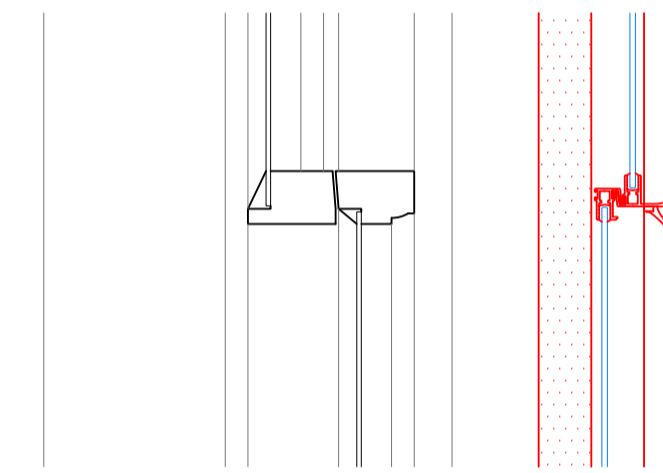

Section G-G
Scale: 1:5 on A1

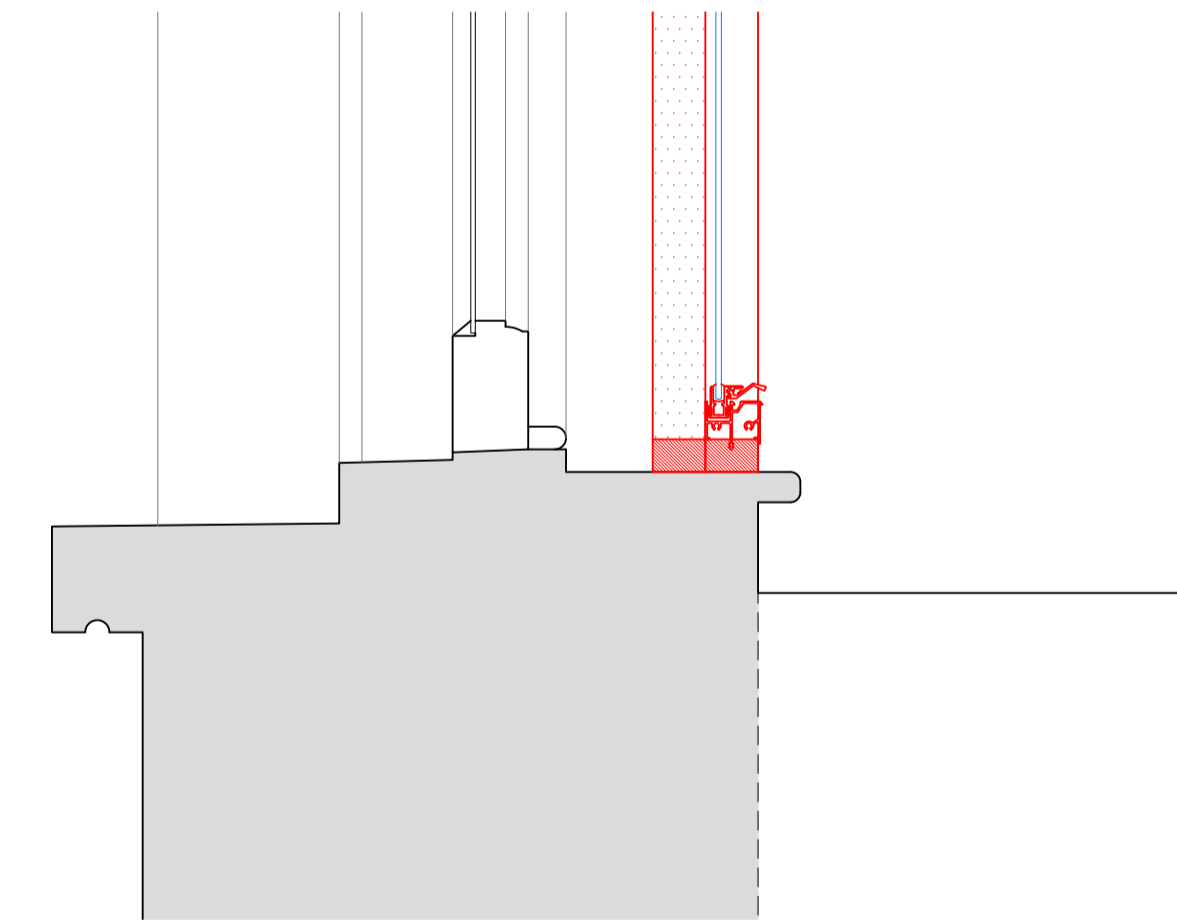

SECONDARY GLAZING SHOWN IN RED FOR VISUAL CLARITY ONLY

Revision	Date	Assessment
1.0	24-10-2019	Issued for listed building consent application

Do not reproduce this drawing without written permission
All dimensions are in millimetres unless stated otherwise

Drawing Not For Construction

HS2

High Speed (HS2) Limited
1st-3rd Floor
The Podium
1 Eversholt Street
London NW1 2DN

COSTAIN SKANSKA

Costain Skanska Joint Venture
2nd Floor
Addison Lee Compound
Granby Terrace
London NW1 3SA

Site Address:
1 Mornington Crescent, Flat 4, London NW1

Drawing Title:
Lower Second Floor - Kitchen: PROPOSED Secondary Glazing Details - Sheet 3 of 3

Drawn by: AP & PB
Checked by: OB
Presentation Scale: 1:5 @ A1

Date: 18-10-2019
Drawing No: WPI P066 NI - 1 MC 4-PR-LSF-J-02.2
Revision: 1.0