

This drawing is copyright and may not be copied or reproduced without written consent of this practice

The contractor is responsible for setting out and must check all levels & dimensions prior to work being put in hand

This drawing should not be scaled. Only written dimensions are to be 1 in respect of this project.

The Architect is to be immediately notified of any suspected omissions or discrepancies

REV	DATE	COMMENT
A	01.04.15	Planning amendments
B	30.12.19	Planning resubmission to vary condition
B	23.01.20	Elevations of equipment added

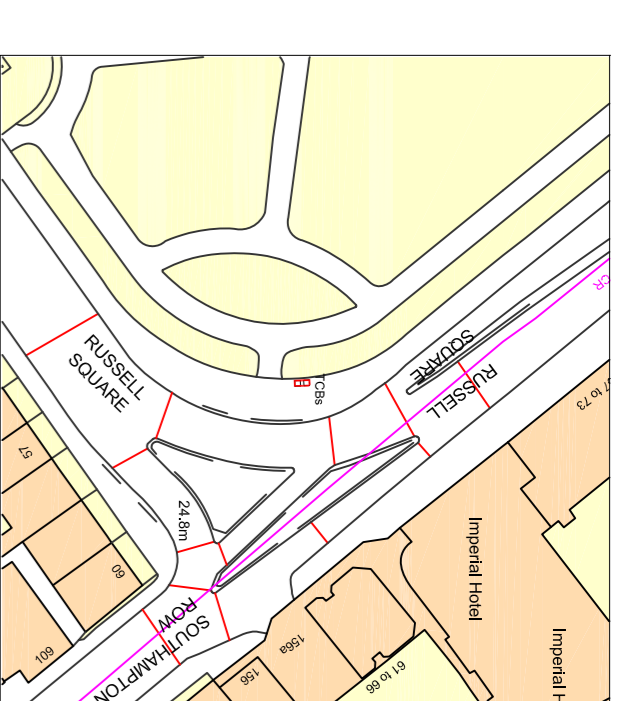
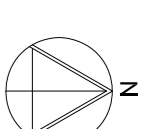

Location Plan  
1:1250

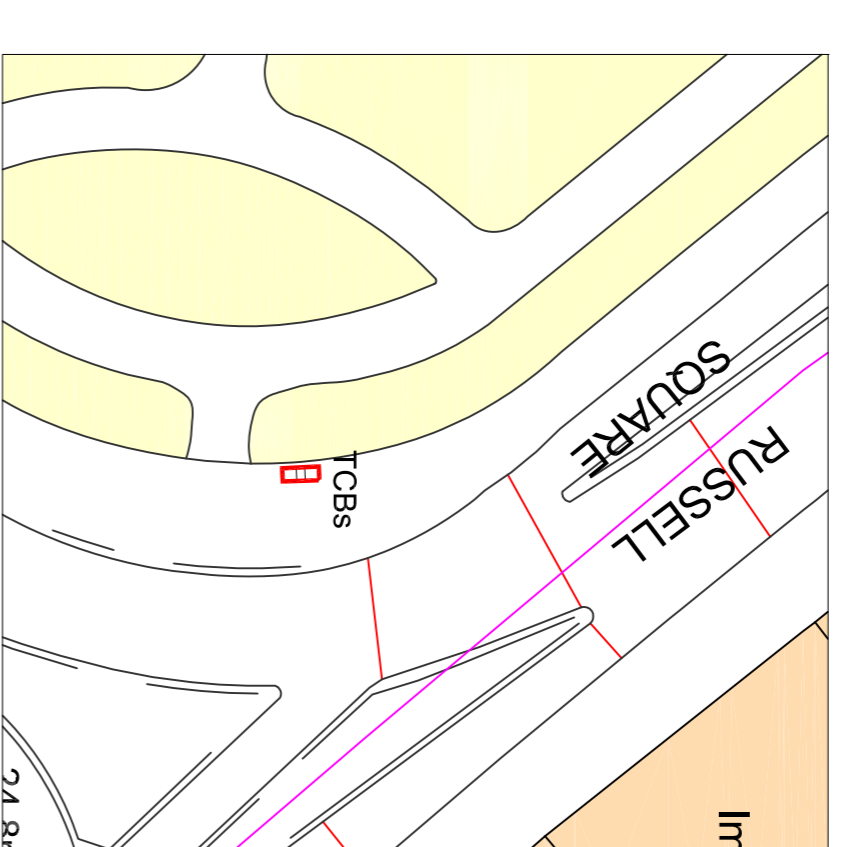

Block Plan  
1:500

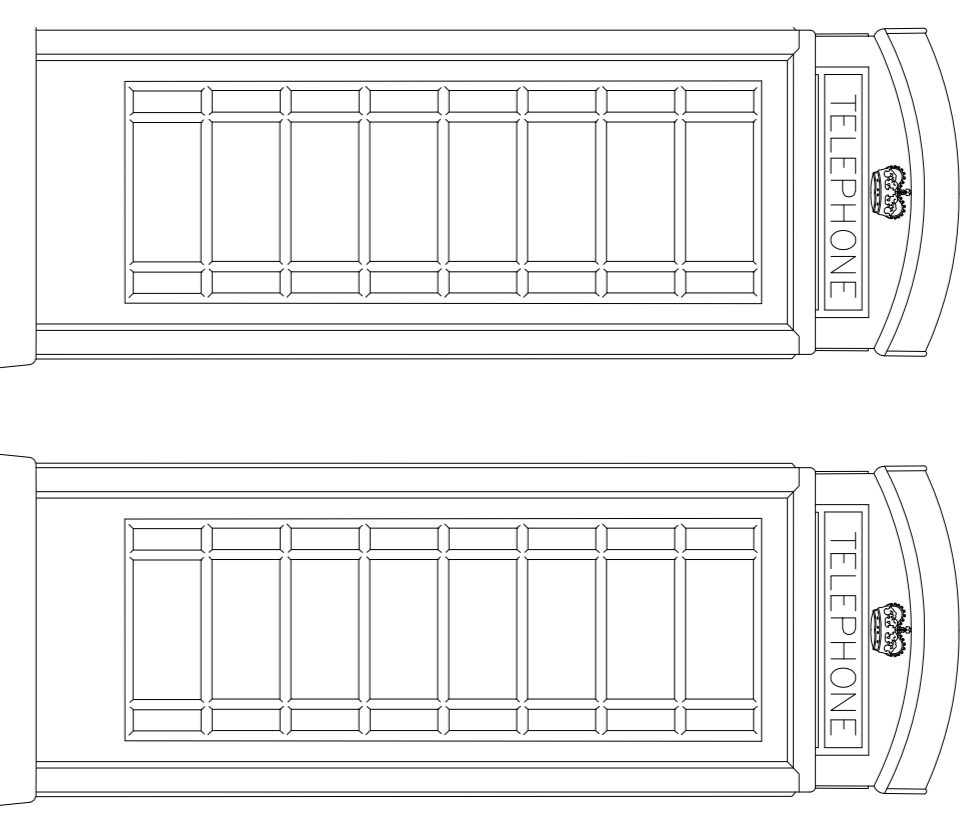

Existing Side (Street) Elevation @ 1:20

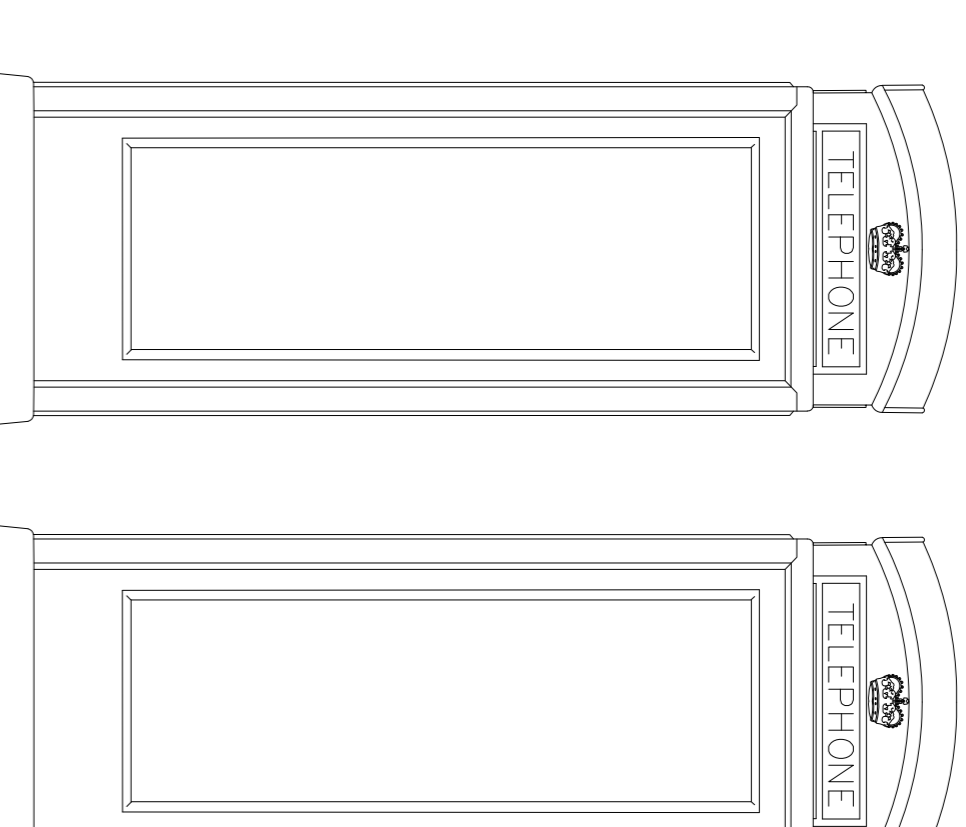

Existing Side Elevation Backing onto Russell Square Gardens @ 1:20

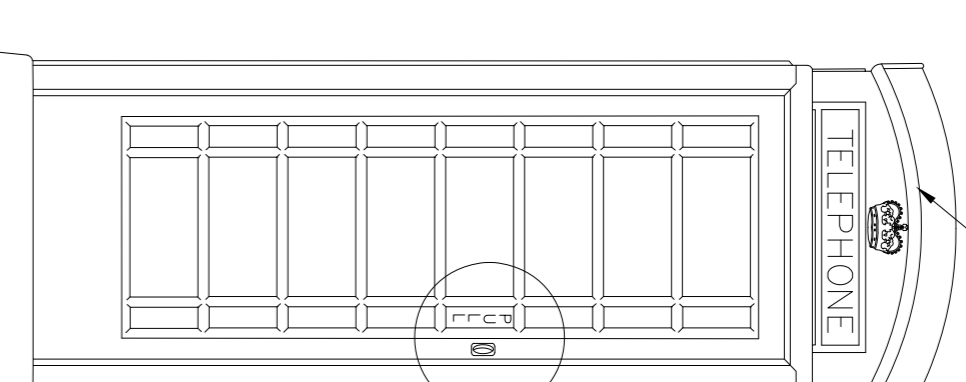

Existing Front Elevation to Box 1 @ 1:20

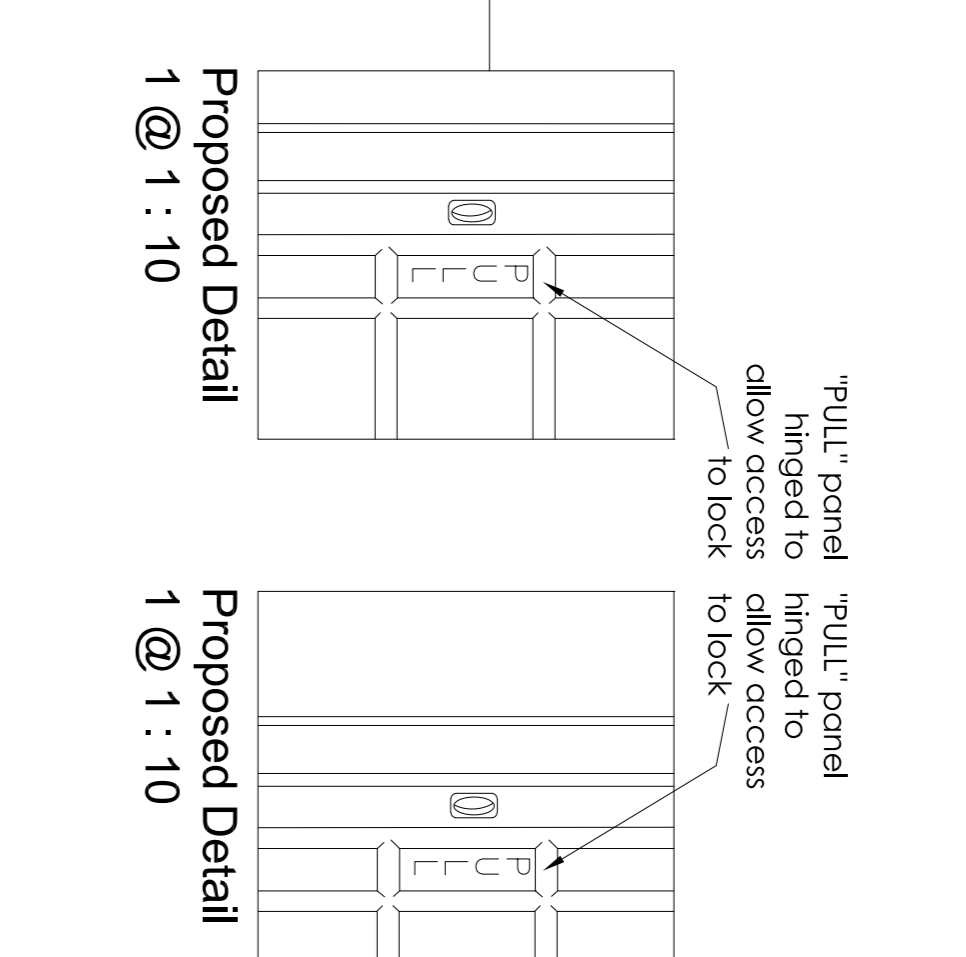

Proposed Detail 1 @ 1:10

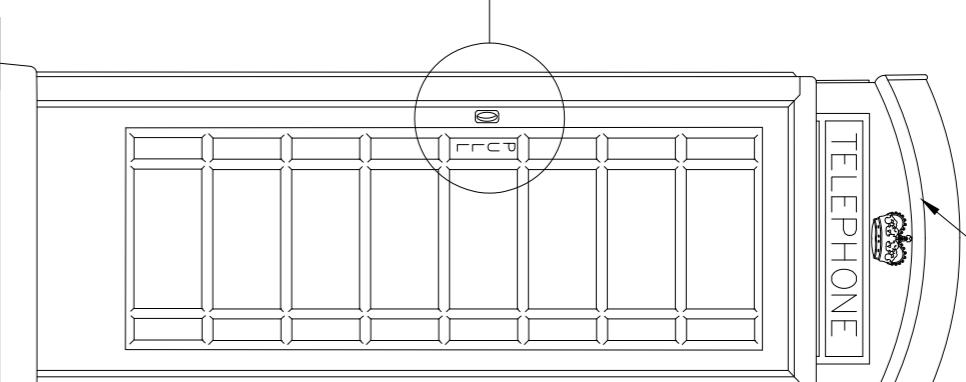

Existing Front Elevation to Box 2 @ 1:20

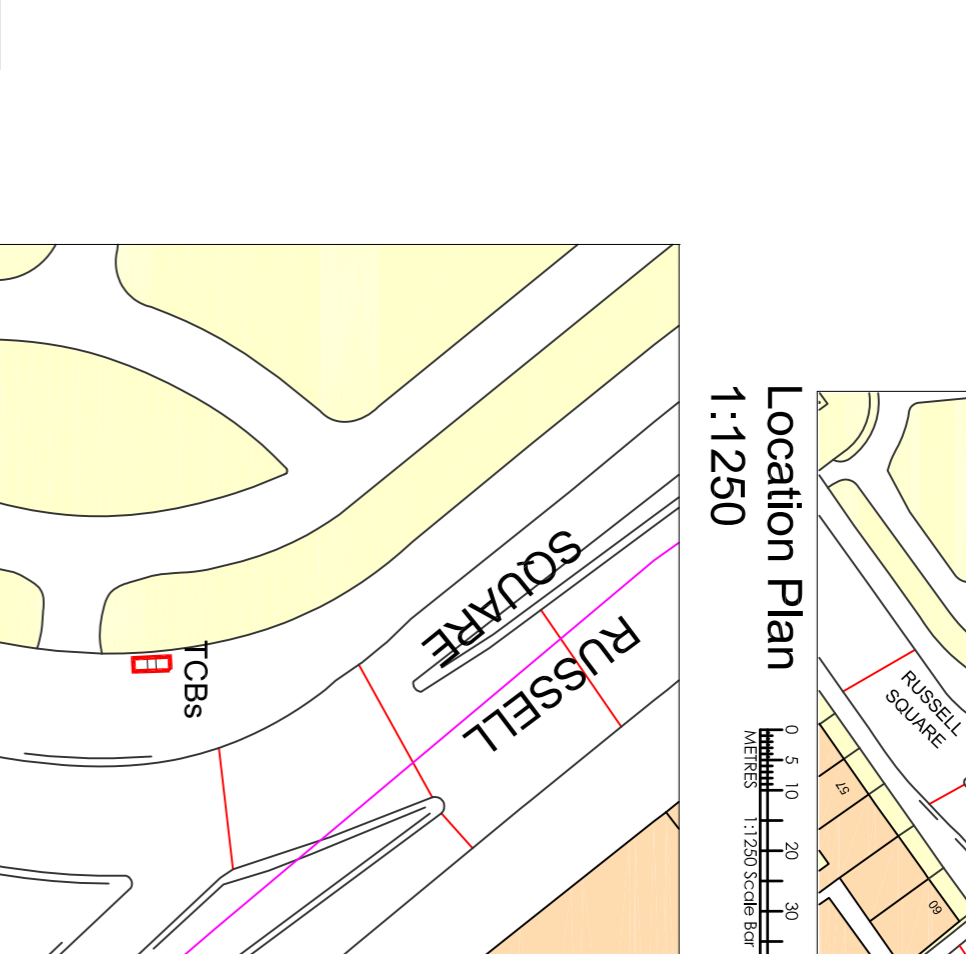

Proposed Detail 1 @ 1:10

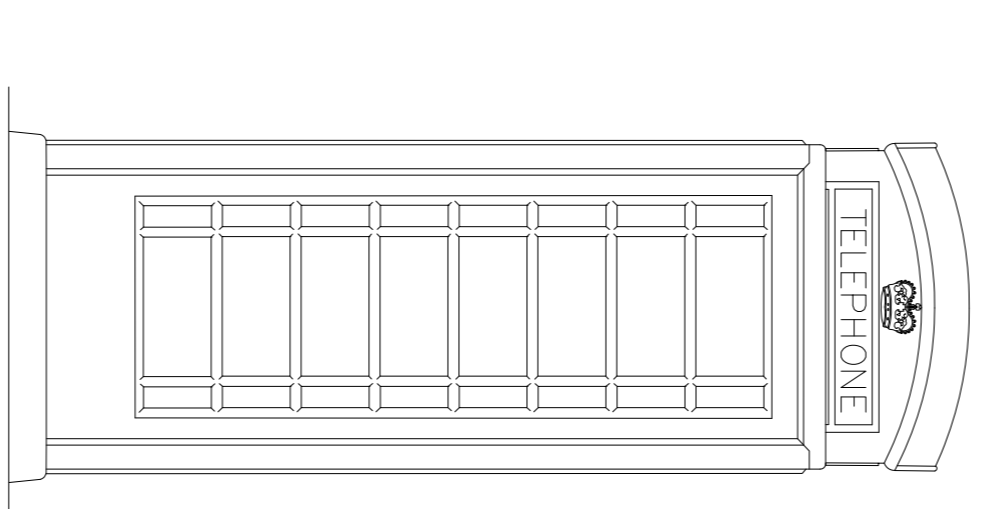

Existing Rear Elevation to Box 1 @ 1:20

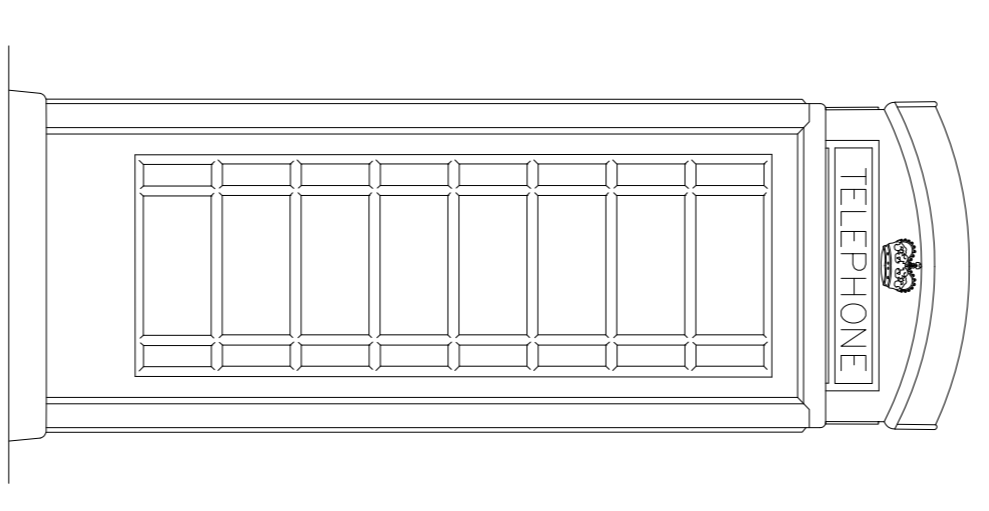

Existing Rear Elevation to Box 2 @ 1:20

Site Elevation  
1:100

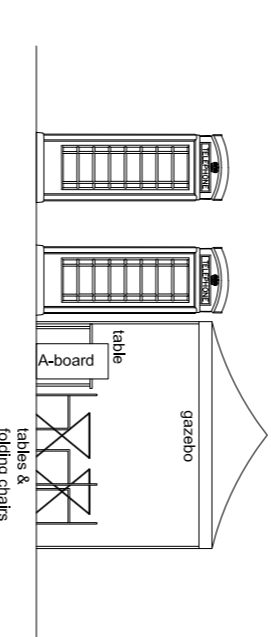

Site Plan  
1:100

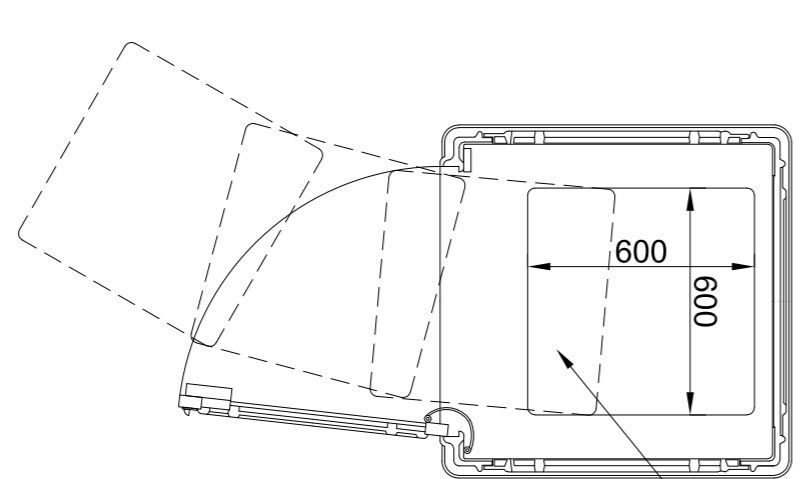
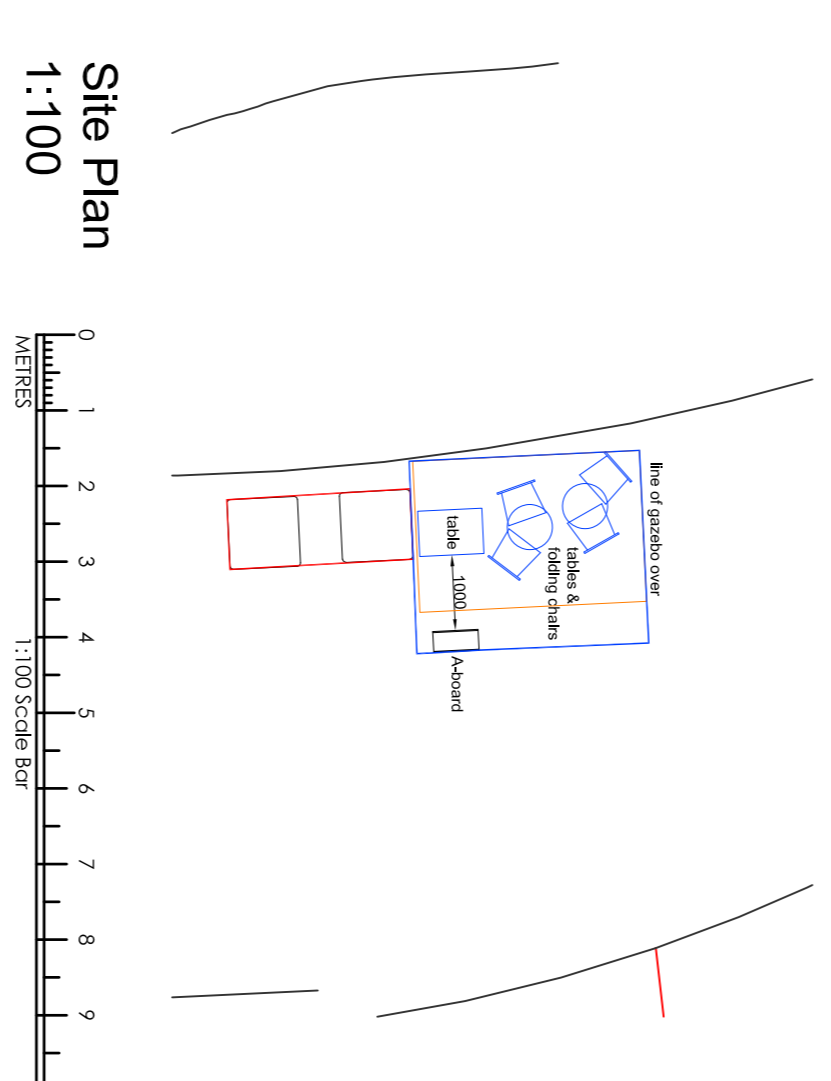

Proposed Plan Showing Door Open & Access for Modular Unit @ 1:20

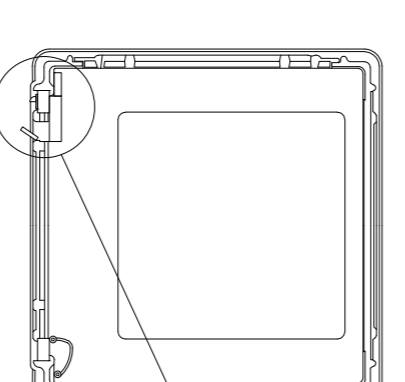

Proposed Plan Showing Door Closed @ 1:20

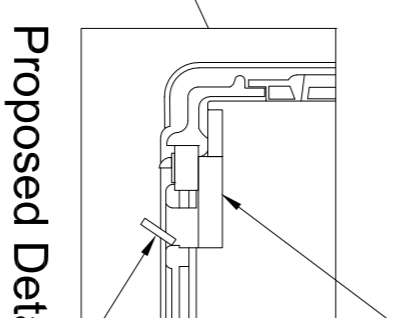

Proposed Detail 2 @ 1:10

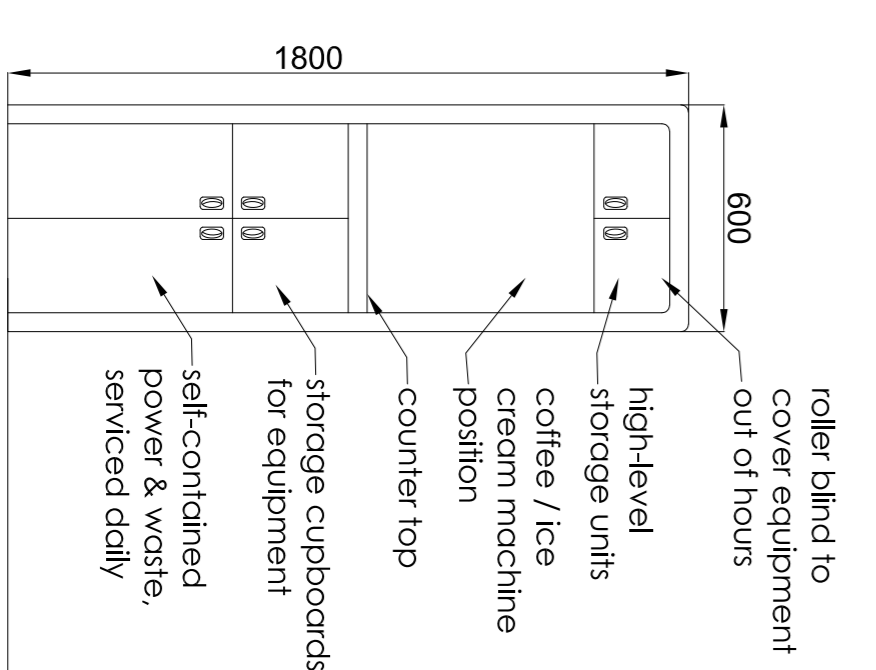

Typical Proposed Elevation of Modular Unit @ 1:20

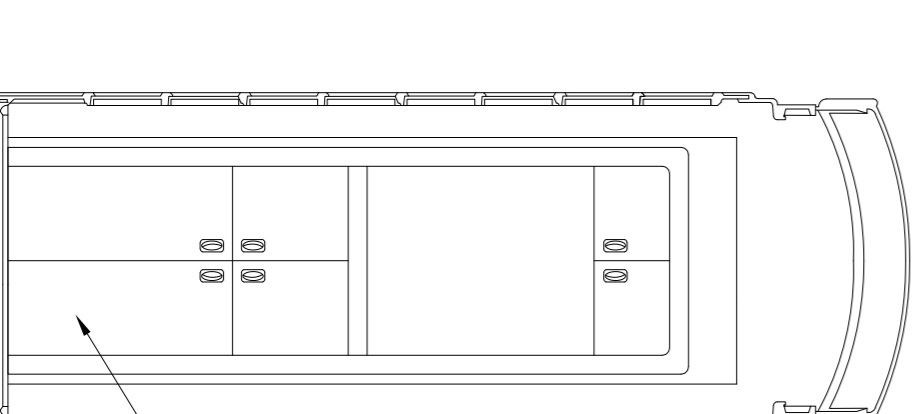

Typical Proposed Section A-A @ 1:20

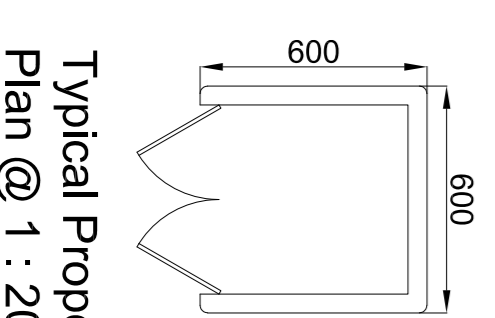
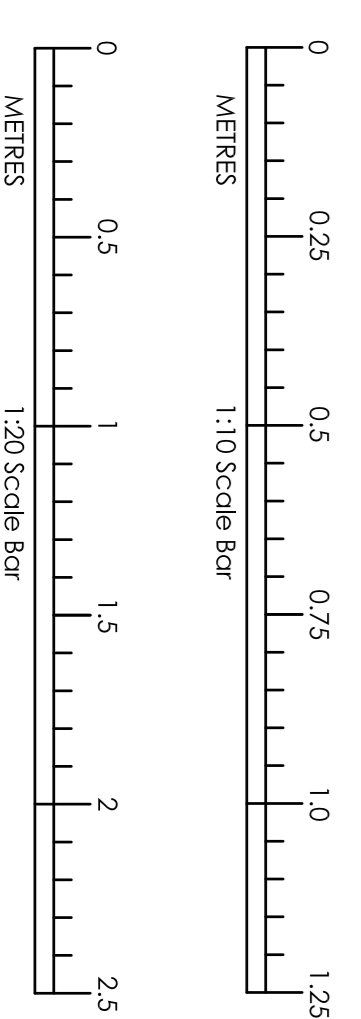

Typical Proposed Kiosk Plan @ 1:20

scale	date	drawn
1:20, 1:500	Feb 2015	FMB
1:1250 @ A1		

PROJECT  
CHANGE OF USE FROM 2NO. PHONE BOXES TO 2NO. RETAIL KIOSKS

@ OPPOSITE "IMPERIAL HOTEL" 61-66 RUSSELL SQUARE, LONDON, WC1B 5BB

CLIENT  
RED KIOSK DESIGNS

MB DESIGN & BUILD LTD  
CHARTERED ARCHITECTS AND PLANNING CONSULTANTS

The Studios  
66 Haven Way, Newhaven  
East Sussex, BN9 5TD  
T: 01323 812172  
www.mbroandco.co.uk

DRAWING  
PROPOSED PLANS, ELEVATION SECTIONS AND EXISTING BLOCK & LOCATION PLANS - K6 KIOSK

job no	drawing no	revision
9232-16.5	PL01	C