

RW01 Specification Notes

This drawing must be read in conjunction with the general notes on drawing 8040.

These notes are for the construction of replica style doors that have no fire requirement. If door has fire requirement see 8040 notes. This drawing indicates the general details of the new door type but must not be used as a fabrication drawing. The contractor must use its expertise to produce accurate shop drawings.

Material: To match existing doors of a similar type (typically Oak).

Panel: Solid timber raised and fielded with moulding as shown in drawing.

Finish: To match colour and texture of existing similar door types (such as E01A) as closely as possible. Allow for 6 samples of 200mm x 200mm Oak panel to be stained and varnished to enable colour and texture of existing to be matched. In the first instance, produce two samples and notify the architect when complete to arrange inspection. After inspection further samples may be required to achieve the closest match possible. (continued below)

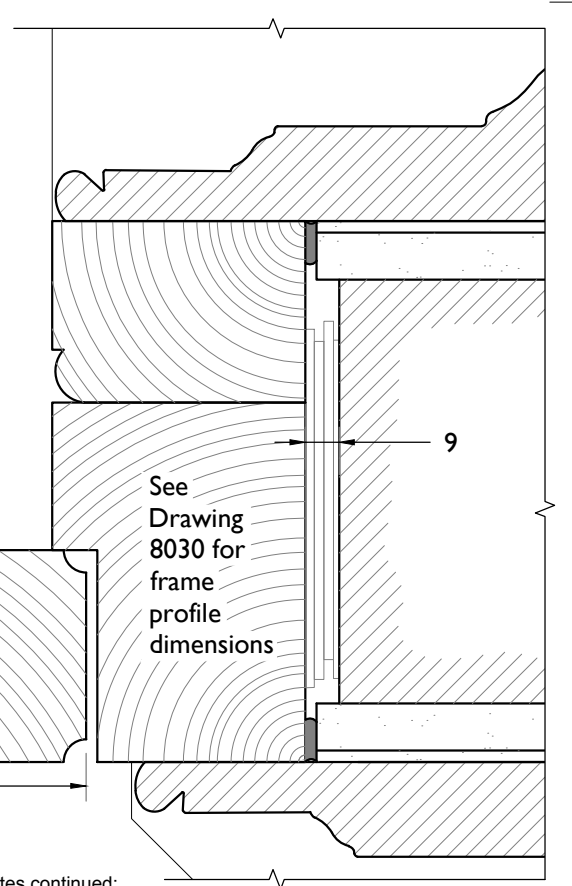

Specification notes continued:

Glazing: Use salvaged copper framed, 9 pane glazing units from existing doors where they are available.

Provide alternative price for a set of new replica copper lights to match existing similar style doors. These are available to order from specialist manufacturers such as Cheam Leaded Lights Limited. New units should use safety glass in accordance with BS 6262: Part 4: 1994 but with consideration of the historic nature of the building with regard to dispensation for visible markings. (<https://www.cheamleadedlights.com/copper-lights/>)

Action: Doors to swing in one direction.

Lock: Provisionally allow for supply and installation of high security five lever mortice deadlock case and escutcheons in polished brass finish.

Bolts: Provisionally allow for supplying and installing upper and lower concealed, lever action flush bolts and keep plates. Material and finish to be polished brass. This is to be a heavy duty bolt.

Hinges: 3x Polished brass butt hinge on each leaf - double phosphor bronze washered to match size of existing hinges.

Finger Plates: No finger plates are required. This is to match existing doors of this type which did not originally have this feature.

Kick Plates: Provisionally allow for polished brass kick plates to the lower section of the door.

Electronic Security: Please see the *Hoare Lea* security design package for electronic locking requirements and specifications for each door. Please note that these requirements are also outlined on the door schedule. However, the door schedule should not be relied upon on its own as the security design package contains the key design and specification information describing the required installation.

Closer (not fire rated): Please see door schedule to establish which doors require a closer. Where a closer is required on a non fire rated door it will be the Abloy DC330 (Brass finish) and associated items required for full installation.

Automation: Please see the door schedule for automation requirements. Automatic door closers will be ASSA ABLOY Entrance systems SW300 with Dual Action Arm - 70mm high universal heavy duty (HD) electro-mechanical operator to comply with European standards. Mounted onto a suitable transom by others.

This operator will allow the door to automatically swing in one direction, and can be manually pushed open in the opposite direction. The unit will spring close when opened manually. It is suitable for inward opening doors that require an emergency open outwards facility.

Notes:

- Drawings are based on survey data and may not accurately represent what is physically present.
- Do not scale from this drawing. All dimensions are to be verified on site before proceeding with the work.
- All dimensions are in millimeters unless noted otherwise.
- Purcell shall be notified in writing of any discrepancies.

- Replica timber door with glazing
- Accessible door
- Clear width with one leaf open 780mm (approx.)
- Single direction (See door schedule for other requirements)
- Brass kick plate to both sides of each leaf

P00	18 Dec 2019			
First Issue	27 Sep 2019	RH	RH	
ISSUE	DATE	DRAWN	CHECKED	DESCRIPTION

CLIENT	Lendlease
PROJECT	Camden Town Hall

DRAWING TITLE	Details of Existing Door Type RW01 Doors such as DG.01-1 with no fire rating
SIZE & SCALE	A3L As Noted
DRAWING STATUS	ISSUED FOR LBC

JOB NUMBER	238664
DRAWING NO.	CTH-PUR-XXX-DR-31-A-8031
REVISION	P00

