



**Tree Survey, Arboricultural Impact Assessment
Arboricultural Method Statement & Tree Protection Plan
In Accordance with BS 5837:2012**

| | | | |
|-------------------------|--|---------------------------|---|
| Proj. No 7757 | 16 Downshire Hill, Hampstead, London, NW3 1NT | | |
| Client: | | Professor and Mrs Fulford | |
| Date of Report: | 05/11/2019 | Revision: | A |

Tree Survey, Arboricultural Impact Assessment, Arboricultural Method Statement & Tree Protection Plan – In Accordance with BS 5837:2012

Summary

The purpose of this report is to provide a consideration of the arboricultural implications created by the proposed development. In accordance with the feasibility and planning sections of BS5837:2012 “*Trees in relation to design, demolition and construction – Recommendations*”, trees deemed to be within the influencing distance of the projected construction have been evaluated for quality, longevity and initial maintenance requirements. Where trees do not have to be removed for health and safety reasons, a detailed and objective assessment has been made of the consequences of the intended layout.

In this circumstance it is intended to renovate the existing property and add a single-storey rear extension. In addition, the rear garden is to be landscaped, and the existing garden building, at the end of the rear garden, is to be replaced by a slightly larger garden study. As a result eight individual trees and two hedges were inspected. The arboricultural related implications of the proposal are as follows:

- 1 In addition to trees which require felling irrespective of development, it is necessary to fell two category ‘B’ trees and one category ‘C’ tree in order to achieve the proposed layout. Additionally, one category ‘B’ tree requires minor surgery to permit construction space.
- 2 Two trees have been identified for removal irrespective of any development proposals. The removal of T005 coincides with the requirements of the proposed layout. One tree, T002, identified thus coincides with the landscape design of the proposal.
- 3 The alignment of garden study encroaches within the Root Protection Areas (RPA) of two trees that are to be retained. In view of this, careful consideration must be given to the foundation design, as discussed at item 4.4.2.
- 4 The alignment of the new garden path encroaches within the RPA of one tree that is to be retained, but given the use of modern “no dig” construction techniques this is not considered to be a substantial issue, as discussed at item 4.4.3.
- 5 Two trees within this survey (T006 and T007) require additional investigation or tree works. It is understood that they lie on neighbouring land and as such the relevant recommendations of this report relating to these two trees should be communicated to the owners as soon as possible.
- 6 This report recommends that specialist advice is obtained by expert practitioners in other disciplines. Such input should always be sought prior to the submission of this report in support of a planning application in order to demonstrate that the techniques and methods hereby proposed are achievable. In this particular circumstance it is necessary to contact the following:
 - Structural Engineer (foundation design, item 4.4.1 and 4.4.2)
 - Civil Engineer (“no dig” surfacing, item 4.4.3)



- 7 All trees and landscape features that are to remain as part of the development should suffer no structural damage provided that the findings with this report are complied with in full. This includes ensuring that protective fencing and ground protection is installed as detailed at items 4.6 and 5.1 of this report.

Given the above, there are no overt or overwhelming arboricultural constraints that can be reasonably cited to preclude the proposed construction.



Contact Details

| Client – Professor and Mrs Fulford | | | |
|--|--|-------------------------------|--|
| Address Flat 63 35 Oval Road London NW1 7BF | Contact Professor and Mrs Fulford | Tel: E-mail: | 07831 358325 kwmf@kwmfulford.com |

| Local Planning Authority – London Borough of Camden Council | | | |
|---|----------------------|-------------------------------|---|
| Address 5 Pancras Square London N1C 4AG | Trees Officer | Tel: E-mail: | 0207 974 5616 planning@camden.gov.uk |

| Arboricultural Consultant – Hayden’s Arboricultural Consultants Limited | | | |
|--|--|-------------------------------|--|
| Address Unit 7 Enterprise House Cherry Orchard Lane Salisbury Wiltshire SP2 7LD | Report Author: Caspar Searle | Tel: E-mail: | 01722 657423 caspar@treesurveys.co.uk |



Contents

- 1.0 Introduction**
- 2.0 The Site**
- 3.0 Tree Survey**
- 4.0 Arboricultural Impact Assessment**
- 5.0 Design Advice, Arboricultural Method Statement & Tree Protection Plan**
- 6.0 Recommendations**
- 7.0 Limitations & Qualifications**
- 8.0 References**
- 9.0 Appendices**



1.0 Introduction

1.1 Terms of Reference

1.1.1 Hayden's Arboricultural Consultants Limited has been commissioned by Metro Projects to prepare a Tree Survey, Arboricultural Impact Assessment, Arboricultural Method Statement and Tree Protection Plan for the existing trees at 16 Downshire Hill, Hampstead, London NW3 1NT.

1.1.2 The site survey was carried out on the 31st July 2019. The relevant qualitative tree data was recorded in order to assess the condition of the existing trees, their constraints upon the prospective development and the necessary protection and construction specifications required to allow their retention as a sustainable and integral part of the completed development.

1.1.3 Information is given on condition, age, size and indicative positioning of all the trees, both on and affecting the site. This is in accordance with the British Standard 5837:2012 *Trees in relation to design, demolition and construction - Recommendations*.

1.2 Scope of Works

1.2.1 The survey of the trees and any other factors are of a preliminary nature. The trees were inspected on the basis of the Visual Tree Assessment (VTA) method as developed by Mattheck and Breloer (1994). The trees were inspected from ground level with no climbing inspections undertaken. It is not always possible to access every tree and as such some measurements may have to be estimated. Trees with estimated measurements are highlighted in the schedule of trees. No samples have been removed from the site for analysis. The survey does not cover the arrangements that may be required in connection with the removal of existing underground services.

1.2.2 Whilst this is an arboricultural report, comments relating to non arboricultural matters are given, such as built structures and soil data. Any opinion thus expressed should be viewed as provisional and confirmation from an appropriately qualified professional sought. Such points are clearly identified within the body of the report.

1.2.3 An intrinsic part of tree inspection in relation to development is the assessment of risk associated with trees in close proximity to persons and property. Most human activities involve a degree of risk with such risks being commonly accepted, if the associated benefits are perceived to be commensurate. In general, the risk relating to trees tends to increase with the age of the trees concerned, as do the benefits. It will be deemed to be accepted by the client that the formulation of the recommendations for all tree management will be guided by the cost-benefit analysis (in terms of amenity), of the tree work.

1.3 Documentation

1.3.1 The following documentation was provided prior to the commencement of the production of this report;

- Email of instruction, received 2nd October 2019, from Kenneth Fulford
- Definition of site boundary – drawing no. LP-01 rev. 00
- Topographical survey – drawing no. 190113
- Existing site plan – drawing no. PA-01 rev. 00
- Proposed site layout – drawing no. PA-01 rev. 0



2.0 The Site

2.1 Overview

2.1.1 The site is a terraced house in a residential street. There is a small, verdant front garden, laid to block paving and it is accessed by a flight of steps from the road. The rear garden is at approximately the height of the first floor and is accessed by a series of steps up from the back door of the property. It contains a dilapidated garden study and a number of trees and shrubs.

2.2 Soils

2.2.1 The soils type commonly associated with this site are slowly permeable and seasonally wet, slightly acid but base-rich loams and clays. They are of moderate fertility and mainly support seasonally wet pastures and woodlands type habitats. This soil type constitutes approximately 19.9% of the total English land mass.

2.2.2 The data given was obtained from a desk top study which provides indications of likely soil types. By definition, this information is not comprehensive and therefore any decisions taken with regards the management, usage or construction on site should be based on a detailed soil analysis.

2.2.3 Further to item 2.2.2, this report provides no information on soil shrinkability. It may be necessary for practitioners in other disciplines (e.g. engineers considering foundation design) to obtain this data as required.

2.3 Statutory Tree Protection

2.3.1 Conservation Area

The site is located within a locality specifically identified by London Borough of Camden Council as a "Conservation Area". This is a planning designation that seeks to provide control over the built environment, but which also has provision for tree protection. The effect of this on the owners, managers or any persons wishing to undertake work on trees sited within a Conservation Area is to require them to submit 6 weeks written notice detailing the surgery or felling they plan to undertake. No work may be carried during the 6-week period unless written permission has been received from London Borough of Camden Council. The Local Planning Authority (LPA) can only prevent works notified to them within the 6-week period by serving a Tree Preservation Order. If this happens, the owner of the tree has a right to object to the serving of the order.

There are certain circumstances where written permission from the LPA may not be necessary before undertaking works. These include;

- Making a tree safe if it is an imminent threat to people or property.
- Removing dead wood, or a dead tree.
- Trees with stem diameters of less than 75mm (measured at 1.5m from ground level). If the works being carried out are to help promote the growth of other trees then trees with stem diameters of less than 100mm (at 1.5m) may be removed or pruned.

Owners, managers or any persons wishing to undertake work as an exemption to the written notification process are **required** to provide the LPA with 5 days' notice prior to attending to a tree which they deem as being dead or dangerous; unless such works are required in an emergency.



It is the tree owner's responsibility to provide proof that the tree was indeed dead or dangerous should this exception be challenged; hence, it is advisable always to request an inspection by the LPA prior to carrying out such operations. Furthermore, and even in the event of an emergency situation, there is still a duty to notify the LPA that work has been completed including supplying an explanation of the necessity. Failure to comply with the requirements of Conservation Area legislation can lead to a maximum fine of up to £20,000 per tree in the Magistrates Court. Fines in the Crown Court are unlimited.

NB: If **detailed planning permission** is granted and as part of the relevant approval, works (felling or surgery) to trees located within a Conservation Area are agreed as acceptable by the LPA, no **additional** written permission to proceed will be required provided that

- i. the planning permission remains live,
- ii. works are in strict accordance with the specification of the extant planning permission, and
- iii. works are being completed solely to implement the detailed planning permission.

3.0 Tree Survey

- 3.1 As part of this survey a total of eight individual trees and two hedges have been identified. These have been numbered T001 – T008 and H001 – H002 respectively.
- 3.2 A topographical survey was provided which showed the position of the trees on site. It should be noted however that topographical surveys are not always comprehensive and sometimes it is considered appropriate to record details of trees and landscape features omitted from or beyond the scope of the plan. If this circumstance occurs, the location of the individual tree or landscape feature is estimated. The position of each tree is shown on the attached drawing no. 7757-D-AIA Rev A.
- 3.3 In order to provide a systematic, consistent and transparent evaluation of the trees included within this survey, they have been assessed and categorised in accordance with the method detailed in item 4.3 of *BS 5837:2012 "Trees in Relation to Design, Demolition and Construction - Recommendations"*. For further information, please see the attached Explanatory Notes.
- 3.4 The detailed assessment of each tree and its work requirements with priorities are listed in the attached Schedule of Trees.
- 3.5 Several items would benefit from tree surgery or additional investigation, be it for health and safety, cultural, aesthetic, or structural reasons as detailed in the attached Schedule of Trees. Including the trees recommended for felling, the items requiring the **most urgent** intervention are as follows:

Within six months:

| | |
|------|--|
| T002 | Fell. |
| T005 | Fell. |
| T007 | Advise owner to have tree inspected within 6 months. |



- 3.6 In accordance with item 4.2.4 (c) of BS 5837:2012, the items inspected and detailed within this report have been selected for inclusion due to the likely influence of any proposed development on the trees, rather than strictly adhering to the curtilage of the site. However, it must be understood that there may be trees beyond the site and not included in this survey which may exert an influence on the development. Where works for cultural, health and safety, quality of life, or development purposes have been recommended on trees outside the ownership of the site, these can only progress with the agreement of the owner, except where it involves portions of the trees overhanging the boundary.

4.0 Arboricultural Impact Assessment

4.1 The Proposal

- 4.1.1 It is proposed to renovate the existing property and add a single-storey rear extension. In addition, the rear garden is to be landscaped, and the existing garden building, at the end of the rear garden, is to be replaced by a slightly larger garden study.

4.2 Access

- 4.2.1 Site access is unencumbered by the Root Protection Area (RPA) of any trees to be retained and there is no vehicle access to the site.

4.3 Demolition

- 4.3.1 Demolition of existing garden building affects the theoretical RPA of the following retained trees – T006 and T007. In order to prevent damage to these specimens work must only be completed by hand within the calculated RPAs and may only commence once protective fencing and ground protection have been installed. In the proximity of the retained trees, all walls and material must be demolished inwards into the footprint of the building and away from the stems (often referred to as “top down, pull back”). The foundation base of the existing structure is to be retained.

4.4 Construction

- 4.4.1 Construction of the rear extension encroaches within the theoretical RPA of one tree to be retained – T008. Given the presence of the existing retaining boundary wall and the notable change of levels between the neighbouring rear gardens no significant root disturbance is considered likely. Therefore, there will be no need for a foundation design that protects tree roots. However, given the proximity of the proposed construction to the trees to be retained, it is recommended that a Structural Engineer is consulted to assess the implications of the tree retention on the required foundation design.
- 4.4.2 Construction of the garden study and its foundations encroach within the theoretical RPA of two retained trees, T006 and T007. The structure will be moved 1 metre, south west, away from the rear boundary and extended approximately 1.7 metres, south west, beyond the existing foundation base. Where the extended footprint encroaches within the RPA of these trees a specialised foundation design has been produced by XUL Architecture, included in Appendix I. This design will provide for raised floor levels and will incorporate a ventilated air space beneath the underside of the slab.



The design also allows for these pads (3 in total, measuring 600 x 600 x 600 mm) to be adjusted if an important root (e.g. greater than 50 mm) is identified during the excavation phase. Otherwise, where necessary, linear root pruning may be carried out during excavation, as part of the access facilitation pruning (AFP) works. This excavation must be carried out using an Air-spade and hand tools (secateurs and handsaw etc.) or hand digging, if soil conditions preclude, and in accordance with item 5.8.2 below. Following this, prior to being backfilled, the foundation hole will be lined with a non-permeable geotextile membrane to prevent phytotoxic concrete adversely affecting the retained trees' roots. These operations will be supervised by the appointed Arboriculturalist. A diagrammatic representation of the affected area is shown on the attached drawing no. 7757-D-AIA Rev A.

4.4.3 Installation of a new footpath encroaches within the RPAs of two trees to be retained – T006 and T007. Provided that these work with finished levels and required load bearings without cutting into the ground, the surfaces should be attended to by the use of “no dig” construction methods. However, the exact specification (adhering to the principles of the sample design) must be designed by a Civil Engineer who can confirm that the finished levels and load bearings are achievable with this type of design without cutting into the ground. In order to protect the RPA of the affected trees, this area should be constructed as a final phase of development with the RPAs initially protected by fencing and ground protection.

4.4.4 Excavation and soil re-modelling is not shown to encroach within the RPA of any retained trees. Therefore, no adverse arboricultural implications are expected.

4.5 Implications of Sloping Ground

4.5.1 The arboricultural implications of the proposed structures are based on an assumption that level changes will not occur within the RPA of trees that are shown to be retained. On this site, there is a considerable level change and as such it is assumed that “cut and fill” operations will be required. If these works cannot be excluded from the calculated RPA of retained trees, a reappraisal of the arboricultural implications will be required.

4.6 Requirement for Tree Barrier Fencing and Ground Protection

4.6.1 Prior to the commencement of works and immediately after the completion of the necessary tree surgery and felling work, protective fencing and ground protection will be installed on site. This must be fit for purpose, in full accordance with the requirements of BS 5837:2012. Fencing and ground protection will require realigning once the garden study construction is complete and, again, when the hard landscaping is undertaken in the rear garden.

4.7 Compound

4.7.1 The site provides limited internal space to locate a construction compound outside the RPA of any trees that are to be retained. As such the project will require careful phasing to manage the storage of materials.

4.8 Phasing

4.8.1 The proposal involves the integration of a number of complex aspects that affect tree protection (e.g. – but not exclusively – access, movement of materials and the installation of services).



For this reason, the project must be carefully phased to ensure the highest level of protection for retained trees at all times. Shown on drawing no. 7757-D-AIA Rev A is an in-depth phasing recommendation to cover the major operations on site as they affect retained trees.

4.9 Monitoring

4.9.1 In accordance with item 6.3 of BS 5837:2012, the site and associated development should be monitored regularly by a competent Arboriculturalist to ensure that the arboricultural aspects of the planning permission are complied with. Shown on drawing no. 7757-D-AIA Rev A is an extensive auditable monitoring schedule to assess the progress of key site events/activities.

4.10 Cultural Implications for Retained Trees

4.10.1 Above ground AFP works are required on T008, as outlined in the Schedule of Works to Allow Development. These works are necessary to permit construction access and provide appropriate working space.

4.10.2 It is anticipated that below ground AFP works are to be required on T006 and T007, also outlined in the Schedule of Works to Allow Development. These works are necessary to facilitate the construction of foundation pads for the garden study.

4.10.3 In both instances, given the amount of pruning necessary and the locations of the works, the AFP is not considered likely to have a significant adverse effect on the trees and landscape features concerned. Further information is provided in the Arboricultural Method Statement & Tree Protection Plan, section 5.8.2.

4.11 Landscape Implications

4.11.1 In addition to the trees necessitating removal for health and safety, cultural or quality of life reasons, (as detailed in the attached Schedule of Works - Irrespective of Development) the items listed in the table below require felling to permit the proposed development to proceed: -

| Feature No | Reason for Removal | BS Category* | Visual Amenity Assessment* |
|------------|-----------------------------------|--------------|----------------------------|
| T001 | To enable new landscaping design. | B1 | Moderate |
| T003 | To enable new landscaping design. | B1 | Moderate |
| T004 | To enable new landscaping design. | C2 | Moderate |

* Please see definitions in the Explanatory Notes attached to this report.

4.12 Post Development Implications

4.12.1 No adverse arboricultural implications are considered reasonably foreseeable for the trees that remain provided that the recommendations of this report are complied with in full.

4.12.2 Due to the dynamic nature of trees and their interaction with the environment, their health and structural integrity is liable to change over time. Because of this it is recommended that all trees on or adjacent to the site be inspected on an annual basis.



4.12.3 As stated in BS 5837:2012, regular maintenance of newly planted trees is of particular importance for at least three years during the critical post-planting period and might, where required by site conditions, planning requirements or legal agreement, be necessary for five years or more. Therefore, the designer of the new landscaping should, in conjunction with the landscape design proposals, prepare a detailed maintenance schedule covering this period, and appropriate arrangements made for its implementation.

5.0 Design Advice, Arboricultural Method Statement & Tree Protection Plan

5.1 Securing of Tree Structure and Root Protection Areas

5.1.1 The trees to be retained will be protected by the use of stout barrier fencing and ground protection installed in the positions indicated on the attached Arboricultural Impact Assessment & Tree Protection drawing no. 7757-D-AIA Rev A. These protection measures will be in accordance with the requirements of BS 5837:2012.

5.1.2 All fencing provided for the safeguarding of trees will be installed prior to any demolition or development commencing on the site, therefore ensuring the maximum protection. The fencing, which must have all weather notices attached stating "Construction Exclusion Zone – No Access", will be regarded as sacrosanct and, once erected, will not be removed or altered without the prior consent of the LPA.

5.1.3 Where footpaths are constructed within the RPA of retained trees, careful attention will be paid to the type of surface treatment used in these areas, details of which are given in item 5.8, below. If possible, these should be installed as a final phase of the project, thereby protecting the RPA throughout the major construction phase of the proposed development.

5.2 Location of Site Office, Compound and Parking

5.2.1 The position of the office, compound and parking will be agreed in writing with the LPA prior to commencement of any permitted development works. Any proposed re-location of these items through the various phases of development will be agreed prior to re-siting with the LPA.

5.3 On Site Storage of Spoil and Building Materials

5.3.1 Prior to and during all construction works on site, no spoil or construction materials will be stored within the RPA of any tree on, or adjacent to the site, even if the proposed development is to be within the RPA. This is to reduce to a minimum the compaction of the roots of the trees. Details of the RPA for each tree where no spoil or building materials will be stored are indicated on the attached Arboricultural Impact Assessment & Tree Protection drawing no. 7757-D-AIA Rev A. Any encroachment within this protected area will only be with the prior agreement of the LPA.

5.3.2 Any facilities for the storage of oils, fuels or chemicals shall be sited on impervious bases and surrounded by impervious bund walls. The volume of the bund compound shall be at least equivalent to the capacity of the tank plus 10%.



If there is a multiple tankage, the compound shall be at least equivalent to the capacity of the largest tank, or the combined capacity of interconnected tanks, plus 10%. All filling points, vents, gauges and sight glasses shall be located within the bund. The drainage system of the bund shall be sealed with no discharge to any watercourse, land or underground strata. Associated pipe-work shall be located above ground and protected from accidental damage. All filling points and tank overflow pipe outlets shall be detailed to discharge downwards into the bund.

- 5.3.3 All material storage facilities and work areas must consider the effects of sloping ground on the movement of potentially harmful liquid spillages towards or into protected areas.

5.4 Programme of Works

- 5.4.1 All tree surgery works, once approved by the LPA, will be carried out prior to any other site works. Once completed, the proposed protective fencing and ground protection will be installed along the lines indicated above. All of this will be carried out prior to commencement of any development works on the site. Outline details of the proposed programme are given in the Design and Construction and Tree Care flow chart attached (Appendix G-1) and included in drawing no. 7757-D-AIA Rev A.

5.5 Tree Surgery

- 5.5.1 All tree work will be agreed with the LPA and will be carried out in line with BS 3998:2010 (Recommendations for Tree Works). An Arboricultural Contractor approved by the LPA will carry out the work. Any alterations to the proposed schedule of works will be agreed with the LPA prior to commencement of works.

5.6 Levels

- 5.6.1 Other than for any specific exception which may be referred to at item 4.0, no alterations to soil levels within the RPA of retained trees are envisaged. However, if it is necessary for these to occur, appropriate measures must be taken to prevent or minimise any detrimental effects on the affected root systems as detailed in 5.6.2 and 5.6.3 below.
- 5.6.2 If it is necessary to excavate so close to trees that roots greater than 50mm diameter are likely to be encountered, particular care will be taken to avoid damage. Excavation in these areas will be undertaken by hand or using an air spade, avoiding any damage to the bark. The roots will be surrounded with sharp sand prior to the replacing of any soil or other material in the vicinity.
- 5.6.3 If it is necessary to raise levels, it is essential that adequate supplies of water and oxygen pass through the soil to the trees' roots. Therefore, where necessary, a granular material will be used which will not inhibit gaseous diffusion. Possible options are no-fines gravel or cobbles. All hard surfaces will be of suitable specification to allow such gaseous diffusion, e.g. brick pavers.

5.7 Services

- 5.7.1 At the time of writing this report, no details on proposed services were available. However, the following principles should be adhered to when planning for their installation.



5.7.2 It is proposed that all underground service runs will be placed outside the RPA of the trees on or adjacent to the site. Where it is not possible to do this, the proposed length infringing the RPA will be hand dug 'broken trenches' (NJUG 4, paragraph 4) to ensure the maximum protection of the trees' roots. The trenches may also be excavated using an air spade, or trenchless technology can be employed if this methodology is considered appropriate by the relevant service company (thus allowing services to pass below and through the roots without the need for traditional excavation). If it is necessary to cut any small roots as part of any of these processes, they should be severed in such a way as to ensure that the final wound is as small as possible and free from ragged, torn ends.

5.7.3 All service runs/trenches where they encroach within the RPA of retained trees will be agreed with the LPA prior to commencement of works.

5.8 **Hard Surface Types & Construction within the Root Protection Area**

5.8.1 Where it is necessary to construct footpaths and other hard surfaces within the RPA as calculated in accordance with BS 5837:2012 (item 4.6.1), it is proposed that the design will comply with the 'no-dig' principles of the Arboricultural Advisory Information Services (AAIS) Practice Note 12 "*Through the Trees to Development*" - the only difference being that instead of a geo-grid, a geo-textile base is provided, and the no-fines road stone is incorporated in and retained by a geo-web cellular confinement system. Given the individual requirements of each site, it is essential that a specialist engineer is consulted to specify the construction detail. Where it is necessary to remove any existing hard surface, or lower the ground level within the RPA, this may expose roots. This operation must be undertaken using hand tools or an air spade. Any roots found should be treated with the greatest care and surrounded by sharp sand to provide a level base. Please note that 'no-dig' surfaces are not always considered acceptable for adoption.

5.8.2 Where it is shown that the construction of the garden study encroaches within the RPA of a retained tree, pad and beam foundations of the extended base have been designed to minimise the detrimental effect of the construction on the tree's roots. Any excavations within the RPA of an affected tree will only be undertaken following exploration of the existing root system with an air spade (or by hand digging, if soil conditions preclude) and the necessary root pruning undertaken to allow excavation without unnecessary pulling and tearing of the roots to be retained. This will ensure minimal damage to tree roots. Prior to being backfilled, the foundation hole will be lined with a non-permeable geotextile membrane to prevent phytotoxic concrete adversely affecting the retained trees' roots.

5.8.3 If boundary fencing is to be erected within the RPA of retained trees, it is proposed that the fence posts will be secured by the use of "Met-Posts" or similar design in order to keep the disturbance and damage of the roots of the trees to a minimum.

5.9 **Reporting and Monitoring Procedures**

5.9.1 In accordance with item 6.3 of BS 5837:2012, the site and associated development should be monitored regularly by a competent arboriculturalist to ensure that the arboricultural aspects of the planning permission (e.g. the installation and maintenance of protective measures and the supervision of specialist working techniques) are implemented.



Furthermore, regular contact between the Site Manager and the Arboriculturalist allows them to effectively deal with and advise on any tree related problems that may occur during the development process. This system should be auditable. Should any issues arise during the arboricultural monitoring of the development the Arboriculturalist will contact the LPA and appropriate action taken only with the prior permission of Metro Projects and the LPA.



6.0 Recommendations

- 6.1 It is recommended that the measures detailed in this report are implemented in full to provide retained trees with the highest level of protection during the process of demolition and construction.
- 6.2 Tree surgery should be completed as detailed in the Schedule of Trees. Where this has been identified for reasons other than to permit development, this work should be completed within the advised timescales irrespective of any development proposals.
- 6.3 The tree surgery works proposed as part of this Survey are recommended to mitigate any identified problems that may be caused by trees in close proximity to the proposed development. To this end, should these recommendations be overruled, this Survey stands as the opinion of Hayden's Arboricultural Consultants Limited, and therefore any damage or injury caused by trees recommended by this practice for felling or tree surgery works, to which the proposed schedule of works has been altered or the tree has been requested to be retained by the LPA, cannot be the responsibility of this practice.



7.0 Limitations & Qualifications

Tree inspection reports are subject to the following limitations and qualifications.

General exclusions

Unless specifically mentioned, the report will only be concerned with above ground inspections. No below ground inspections will be carried out without the prior confirmation from the client that such works should be undertaken.

The validity, accuracy and findings of this report will be directly related to the accuracy of the information made available prior to and during the inspection process. No checking of independent third-party data will be undertaken. Hayden's Arboricultural Consultants Limited will not be responsible for the recommendations within this report where essential data are not made available or are inaccurate.

This report will remain valid for one year from the date of inspection but will become invalid if any building works are carried out upon the property, soil levels altered in any way close to the property, or tree work undertaken. It must also be appreciated that recommendations proposed within this report may be superseded by extreme weather, or any other unreasonably foreseeable events.

If alterations to the property or soil levels are carried out, or tree work undertaken, it is strongly recommended that a new tree inspection be carried out.

It will be appreciated, and deemed to be accepted by the client and their insurers, that the formulation of the recommendations for the management of trees will be guided by the following: -

1. The need to avoid reasonably foreseeable damage.
2. The arboricultural considerations - tree safety, good arboricultural practice (tree work) and aesthetics.

The client and their insurers are deemed to have accepted the limitation placed on the recommendations by the sources quoted in the attached report. Where sources are limited by time constraints or the client, this may lead to an incomplete quantification of the risk.

Signed:



November 2019

For and on Behalf of Hayden's Arboricultural Consultants Limited



8.0 References

British Standards Institute. (2010). *Recommendations for Tree Work BS 3998:2010* BSI, London.

British Standards Institute. (2012). *Trees in Relation to Design, Demolition and Construction – Recommendations BS5837:2012* BSI, London.

Ministry of Housing, Communities & Local Government. (2014). *Tree Preservation Orders and trees in conservation areas*. London: Ministry of Housing, Communities & Local Government.

Mattheck & Breloer, H. (1994). *Research for Amenity Trees No.4: The Body Language of Trees*, HMSO, London.

NHBC Standards (2007) *Chapter 4.2 'Building Near Trees'*. National House-Building Council.

NJUG 4 Guidelines for the planning, installation and maintenance of utility apparatus in proximity to trees. Issued 16 November 2007.

Patch, D. Holding, B. (2006) *Arboricultural Practice Note 12 (APN12), Through the Trees to Development*. Arboricultural Advisory and Information Service (AAIS).



9.0 Appendices

| | | |
|----------|----------|--|
| Appendix | A | Species List & Tree Problems |
| Appendix | B | Schedule of Trees |
| Appendix | C | Schedule of Works - Irrespective of Development |
| Appendix | D | Schedule of Works to Allow Development |
| Appendix | E | Explanatory Notes |
| Appendix | F | Tree Preservation Order Enquiry/Response |
| Appendix | G | Advisory Information & Sample Specifications |
| | 1. | BS 5837:2012 Figure 1 - Flow Chart – Design and Construction & Tree Care |
| | 2. | European Protected Species and Woodland Operations Checklist (v.4) |
| | 3. | BS 5837:2012 Figure 2 - Default specification for protective barrier |
| | 4. | BS 5837:2012 Figure 3 - Examples of above-ground stabilising systems |
| | 5. | Method Statement for 'No Dig' Construction in line with Arboricultural Practice Note 12 <i>'Through the Trees to Development'</i> |
| | 6. | MultiTrack Ground Guards Specification |
| Appendix | H | Drawing no. 7757-D-AIA Rev A |
| Appendix | I | Drawing - plan/flank elevation sketches of garden study |



Appendix A - Species List & Tree Problems

Species List:

| | |
|----------------------|---------------------------------|
| Apple | <i>Malus sp</i> |
| Atlas Cedar | <i>Cedrus atlantica</i> |
| Bay Laurel | <i>Laurus nobilis</i> |
| Cotoneaster | <i>Cotoneaster sp</i> |
| Elder | <i>Sambucus nigra</i> |
| Eucalyptus | <i>Eucalyptus gunnii</i> |
| Goat Willow | <i>Salix caprea</i> |
| Japanese Maple | <i>Acer palmatum</i> |
| Viburnum | <i>Viburnum sp</i> |
| Weeping Silver Birch | <i>Betula pendula 'Youngii'</i> |

Tree Problems:

This gives a brief description of the problems identified in the attached Tree Survey.

| | |
|--|---|
| Name: Deadwood | |
| Symptoms/damage type and cause: | This relates to dead branches in the crown of the tree. In the majority of cases, this is caused by the natural ageing process of the tree or shading due to its close proximity to neighbouring trees. However, in some situations, it may be related to fungal, bacterial or viral infection. |
| Consequence: | Depending upon the location and mass of dead wood removal of the affected tissue may be necessary to prevent harm to persons or property as the wood will become unstable as it decays and in some circumstances is likely to fall from the tree with little or no warning. |
| Control: | Detailed monitoring should be undertaken on those trees showing signs of excessive deadwood production to identify the underlying cause. |
| Species affected: | Most tree species. |
| Images: |  |



Appendix B

Schedule of Trees

SCHEDULE OF TREES (AIA) 16 Downshire Hill, Hampstead, London,

Surveyed By: Caspar Searle
Managed By: Caspar Searle

Date:

| TreeNo | Species | DBH | Height | | Visual | Crown Spread | Problems / Comments | BS Cat | Work Required (TS) | Priority (TS) | Work Required (AIA) | Priority (AIA) | |
|--------|-----------------------|--------|----------|-----------------------|----------|------------------------|--|--------|--|---------------|-----------------------------|----------------|---|
| | | | Min Dist | Crown Base | | | | | | | | | Lowest Branch |
| | | | On site | RPA (m ²) | Aspect | Aspect | | | | | | | SULE |
| H001 | Viburnum | 80 | 2 | | Moderate | N0.5, E0.5, S0.5, W0.5 | Unkempt hedge, growing through railings. | C2 | No work required. | 4 | | | |
| | | 0.96 | 0-2m | | EM | Moderate | | | | | | | |
| | | Yes | 2.9 | | | 10+ years | | | | | | | Block paving, Light undergrowth |
| H002 | Cotoneaster, Viburnum | 50 | 2 | | Low | N0.5, E0.5, S0.5, W0.5 | Unkempt, mixed species hedge. | C2 | No work required. | 4 | | | |
| | | 0.6 | 0-2m | | EM | Moderate | | | | | | | |
| | | Yes | 1.1 | | | 10+ years | | | | | | | Block paving |
| T001 | Atlas Cedar | 210 | 7 | | Moderate | N3.5, E3, S3, W3 | Good, young specimen. Growing space restricted by retaining wall, boundary wall and block paving. Some minor deformation to path on south-eastern aspect. Small <30mm cavity at base on southern aspect. Good form and vitality. While it is a good specimen its restricted growing environment is likely to restrict the longevity of this tree in the long term. | B1 | No work required. | 4 | Fell to permit landscaping. | 0 | |
| | | 2.52 | 0-2m | | SM | Moderate | | | | | | | |
| | | Yes | 20 | | | 20+ years | | | | | | | Bare earth, Block paving, Light undergrowth |
| T002 | Japanese Maple | 94.9 | 3 | | Low | N1.5, E2.5, S2, W2 | Poor specimen, poor pruning wounds throughout crown with evidence of decay spreading. Reduced vitality. | U | Fell. | 3 | | | |
| | | 1.1388 | 0-2m | | EM | Moderate | | | | | | | |
| | | Yes | 4.1 | | | <10 years | | | | | | | Building, Light undergrowth |
| T003 | Apple | 230 | 5.5 | | Moderate | N3, E3.5, S3.5, W3 | Good specimen. Slightly congested crown, with crossing branches and minor deadwood. | B1 | Light crown lift to 2m above ground level on northern and eastern aspects. Lightly thin (max 10%) by removing crossing branches. | 3 | Fell to permit landscaping. | 0 | |
| | | 2.76 | 0-2m | | EM | Moderate | | | | | | | |
| | | Yes | 23.9 | | | 20+ years | | | | | | | Grass |
| T004 | Bay Laurel | 423.3 | 9 | | Moderate | N4.5, E4, S3.5, W3.5 | Over-stood coppice. Some displacement of block paving on southern and western aspects. Tight unions at base with some girdling. Crossing and rubbing branches. Previously pollarded at circa. 6m. Slightly etiolated for species, good vitality. | C2 | No work required. | 4 | Fell to permit landscaping. | 0 | |
| | | 5.0796 | 0-2m | | M | Moderate | | | | | | | |
| | | Yes | 81.1 | | | 10+ years | | | | | | | Bare earth, Block paving |

| TreeNo | Species | DBH | Height | | Visual | Crown Spread | Problems / Comments | BS Cat | Work Required (TS) | Priority (TS) | Work Required (AIA) | Priority (AIA) |
|-------------|---------------|-----------------------|------------|---------------|-----------|----------------------|--|--------|--|---------------|---|----------------|
| | | Min Dist | Crown Base | Lowest Branch | Age | Water Demand | | | | | | |
| | | RPA (m ²) | Aspect | Aspect | SULE | Ground Cover | | | | | | |
| T005 | Elder | 170 | 5 | | Low | N3, E3.5, S2.5, W3 | Growing from corner of adjacent building. Large cavity extending from base to circa. 1.2m above ground level, poor resonance when sounded with sounding mallet. Minor deadwood throughout crown and reduced vitality. | U | Fell. | 2 | | |
| | | 2.04 | 0-2m | | M | Moderate | | | | | | |
| Yes | | 13.1 | | | <10 years | Bare earth, Building | | | | | | |
| T006 | Eucalyptus | 520 | 12 | | Moderate | N4, E6, S5, W3.5 | Off-site location impeded detailed inspection. Previously pollarded at circa. 1.5m and circa. 3m above ground level. Vigorous regrowth from pollard points with poor, decayed unions. Poor specimen due to past management. Borderline C/U specimen. | U | Advise owner that the tree should repollarded to previous pruning points circa. 3m., or to fell and replace. | 3 | Undertake linear root pruning, if necessary | 0 |
| | | 6.24 | 0-2m | | M | High | | | | | | |
| No | | 122.3 | | | <10 years | Bare earth, Grass | | | | | | |
| T007 | Goat Willow | 450 | 14 | | High | N6, E5, S5.5, W5.5 | Detailed inspection impeded as tree located off-site and presence of shed with exposed asbestos. Lean to north east. Resting on boundary wall and shed. Minor deadwood in crown and reduced vitality. | C2 | Advise owner to have tree inspected within 6 months. | 2 | Undertake linear root pruning, if necessary | 0 |
| | | 5.4 | 2.1-4m | | M | High | | | | | | |
| No | | 91.6 | | | 10+ years | Bare earth, Building | | | | | | |
| T008 | Weeping Birch | 320 | 5 | | Low | N4, E4, S4, W4 | Broad, flat and spreading crown. Vine encroaching slightly on northern and eastern aspect. Unlikely that roots will pass boundary, retaining wall. | B1 | No work required. | 4 | | |
| | | 3.84 | 0-2m | | M | Low | | | | | | |
| No | | 46.3 | | | 10+ years | Building, Grass | | | | | | |

Appendix C

Schedule of Works - Irrespective of Development

SCHEDULE OF WORK

16 Downshire Hill, Hampstead, London,

Surveyed By: Caspar Searle

Surveyed:

Managed By: Caspar Searle

| Tree No. | Species | Work required | Priority |
|-------------|----------------|--|----------|
| T005 | Elder | Fell. | 2 |
| T007 | Goat Willow | Advise owner to have tree inspected within 6 months. | 2 |
| T002 | Japanese Maple | Fell. | 3 |
| T003 | Apple | Light crown lift to 2m above ground level on northern and eastern aspects. Lightly thin (max 10%) by removing crossing branches. | 3 |
| T006 | Eucalyptus | Advise owner that the tree should repollarded to previous pruning points circa. 3m., or to fell and replace. | 3 |

Appendix D

Schedule of Works to Allow Development

SCHEDULE OF WORKS (AIA)

16 Downshire Hill, Hampstead, London,

Surveyed By: Caspar Searle

Surveyed:

Managed By: Caspar Searle

| Tree No. | Species | Work required | Priority |
|-------------|-------------|---|----------|
| T001 | Atlas Cedar | Fell to permit landscaping. | 0 |
| T003 | Apple | Fell to permit landscaping. | 0 |
| T004 | Bay Laurel | Fell to permit landscaping. | 0 |
| T006 | Eucalyptus | Undertake linear root pruning, if necessary | 0 |
| T007 | Goat Willow | Undertake linear root pruning, if necessary | 0 |

Appendix E

Explanatory Notes

Explanatory Notes



Categories

Below is an explanation of the categories used in the attached Tree Survey.

No Identifies the tree on the drawing.

Species Common names are given to aid understanding for the wider audience.

BS 5837 Main Category Using this assessment (BS 5837:2012, Table 1), trees can be divided into one of the following simplified categories, and are differentiated by cross-hatching and by colour on the attached drawing:

Category A - Those of high quality with an estimated remaining life expectancy of at least 40 years;

Category B - Those of moderate quality with an estimated remaining life expectancy of at least 20 years;

Category C - Those of low quality with an estimated remaining life expectancy of at least 10 years, or young trees with a stem diameter below 150 mm;

Category U - Those trees in such condition that they cannot realistically be retained as living trees in the context of the current land use for longer than 10 years.

BS 5837 Sub Category Table 1 of BS 5837:2012 also requires a sub category to be applied to the A, B, C, and U assessments. This allows for a further understanding of the determining classification as follows:

Sub Category 1 - Mainly arboricultural qualities;

Sub Category 2 - Mainly landscape qualities;

Sub Category 3 - Mainly cultural values, including conservation .

Please note that a specimen or landscape feature may fulfil the requirements of more than one Sub Category.

DBH (mm) Diameter of main stem in millimetres at 1.5 metres from ground level. Where the tree is a multi-stem, the diameter is calculated in accordance with item 4.6.1 of BS 5837:2012.

Age Recorded as one of seven categories:

Y Young. Recently planted or establishing tree that could be transplanted without specialist equipment, i.e. less than 150 mm DBH.

S/M Semi-mature. An established tree, but one which has not reached its prospective ultimate height.

E/M Early-mature. A tree that is reaching its ultimate potential height, whose growth rate is slowing down but if healthy, will still increase in stem diameter and crown spread.

M Mature. A mature specimen with limited potential for any significant increase in size, even if healthy.

O/M Over-mature. A senescent or moribund specimen with a limited safe useful life expectancy. Possibly also containing sufficient structural defects with attendant safety and/or duty of care implications.



D Dead.

| | |
|---------------------------|---|
| Height | Recorded in metres, measured from the base of the tree. |
| Crown Base | Recorded in metres, the distance from ground and aspect of the lowest branch material. |
| Lowest Branch | Recorded in metres, the distance from ground and aspect of the emergence point of the lowest significant branch. |
| Life Expectancy | Relates to the prospective life expectancy of the tree and is given as 4 categories: 1 = 40 years+; 2 = 20 years+; 3 = 10 years+; 4 = less than 10 years. |
| Crown Spread | Indicates the radius of the crown from the base of the tree in each of the northern, eastern, southern and western aspects. |
| Minimum Distance | This is a distance equal to 12 times the diameter of the tree measured at 1.5 metres above ground level for single stemmed trees and 12 times the average diameter of the tree measured at 1.5 metres above ground level tree for multi stemmed specimens. (BS 5837:2012, section 4.6). |
| RPA | This is the Root Protection Area, measured in square metres and defined in BS5837:2012 as “a layout design tool indicating the minimum area around a tree deemed to contain sufficient roots and rooting volume to maintain the tree’s viability, and where the protection of the roots and soil structure is treated as a priority”. The RPA is shown on the drawing.. Ideally this is an area around the tree that must be kept clear of construction, level changes of construction operations. Some methods of construction can be carried out within the RPA of a retained tree but only if approved by the Local Planning Authority’s tree officer. |
| Water Demand | This gives the water demand of the species of tree when mature, as given in the NHBC Standards Chapter 4.2 “Building Near Trees”. |
| Visual Amenity | Concerns the planning and landscape contribution to the development site made by the tree, hedge or tree group, in terms of its amenity value and prominence on the skyline along with functional criteria such as the screening value, shelter provision and wildlife significance. The usual definitions are as follows: Low An inconsequential landscape feature. Moderate Of some note within the immediate vicinity, but not significant in the wider context. High Item of high visual importance. |
| Problems/ Comments | May include general comments about growth characteristic, how it is affected by other trees and any previous surgery work; also, specific problems such as deadwood, pests, diseases, broken limbs, etc. |
| Work Required (TS) | Identifies the necessary tree work to mitigate anticipated problems and deal with existing problems identified in the “Problems/comments” category. |



Work Required (AIA)

Identifies the tree work specifically necessary to allow a proposed development to proceed.

Priority

This gives a priority rating to each tree allowing the client to prioritise necessary tree works identified within the Tree Survey.

- 1 Urgent – works required immediately;
- 2 Works required within 6 months;
- 3 Works required within 1 year;
- 4 Re-inspect in 12 months,
- 0 Remedial works as part of implementation of planning consent.



BS 5837:2012 Terms and Definitions

| | |
|--|---|
| Access Facilitation Pruning | One-off tree pruning operation, the nature and effects of which are without significant adverse impact on tree physiology or amenity value, which is directly necessary to provide access for operations on site. |
| Arboricultural Method Statement | Methodology for the implementation of any aspect of development that is within the root protection area, or has the potential to result in loss of or damage to a tree to be retained. |
| Arboriculturist | Person who has, through relevant education, training and experience, gained expertise in the field of trees in relation to construction. |
| Competent Person | Person who has training and experience relevant to the matter being addressed and an understanding of the requirements of the particular task being approached. <i>NOTE - a competent person is expected to be able to advise on the best means by which the recommendations of this British Standard may be implemented.</i> |
| Construction | Site-based operations with the potential to affect existing trees. |
| Construction Exclusion Zone | Area based on the root protection area from which access is prohibited for the duration of a project. |
| Root Protection Area (RPA) | Layout design tool indicating the minimum area around a tree deemed to contain sufficient roots and rooting volume to maintain the tree's viability, and where the protection of the roots and soil structure is treated as a priority. |
| Service | Any above or below ground structure or apparatus required for utility provision. NOTE - examples include drainage, gas supplies, ground source heat pumps, CCTV and satellite communications. |
| Stem | Principal above ground structural component(s) of a tree that supports its branches. |
| Structure | Manufactured object, such as a building, carriageway, path, wall, service run, and built or excavated earthwork. |
| Tree Protection Plan | Scale drawing, informed by descriptive text where necessary, based upon the finalized proposals, showing trees for retention and illustrating the tree and landscape protection measures. |
| Veteran Tree | Tree that, by recognized criteria, shows features of biological, cultural or aesthetic value that are characteristic of, but not exclusive to, individuals surviving beyond the typical age range for the species concerned. NOTE - these characteristics might typically include a large girth, signs of crown retrenchment and hollowing of the stem. |



Appendix F

Tree Preservation Order Enquiry/Response

Gabrielle Justesen

From: Curry, Rav <Rav.Curry@camden.gov.uk>
Sent: 19 July 2019 15:46
To: Gabrielle Justesen
Subject: RE: TPO Enquiry

Importance: High

Hi Gabby

There are no TPOs at this location or the one next door, behind or in front.

However this location and all of the properties around it in all directions do fall within the Hampstead Conservation Area and therefore permission would be required from London Borough of Camden to carry out any works to trees.

Kind regards

Rav Curry
Planning Assistant
London Borough of Camden



From: Gabrielle Justesen <Gabby@treesurveys.co.uk>
Sent: 19 July 2019 12:15
To: Planning <Planning@camden.gov.uk>
Subject: TPO Enquiry

Dear Sir or Madam,

Could you please advise if the above mentioned site and adjacent areas (and the neighbouring properties) are covered by TPO or located within a Conservation Area?

I have attached a map for your use.

I look forward to hearing from you.

Kind regards

Gabby Justesen
Office Manager – South West Office

(Please note my working hours are 9am – 3pm)



Appendix G

Advisory Information & Sample Specifications

1. BS 5837:2012 Figure 1 - Flow Chart – Design and Construction & Tree Care

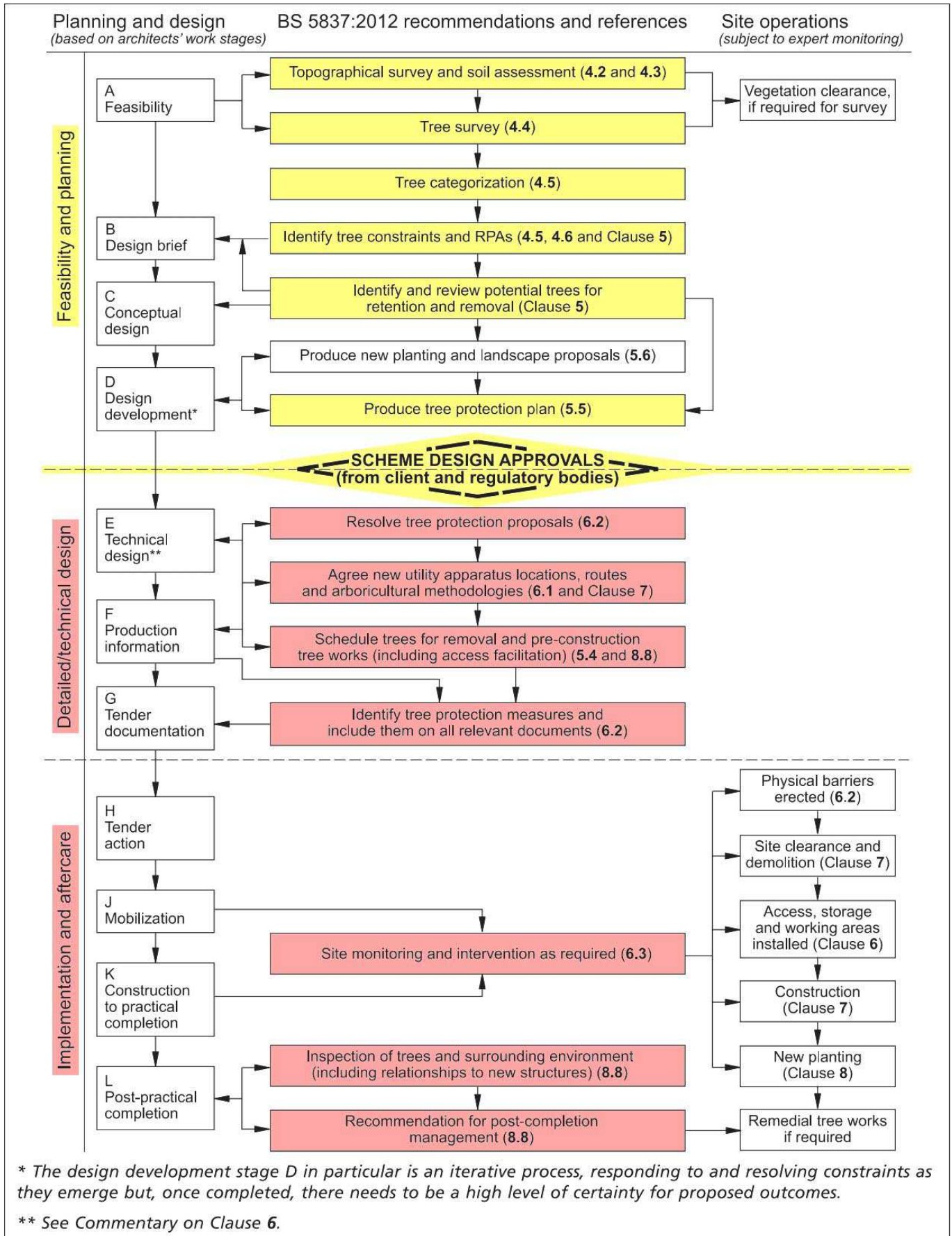

European Protected Species and woodland operations. (V4)

Complete all sections of the Checklist

| Checklist | | Details | | | | | | | | | | |
|----------------------|---|--|--|--|--|--|--|--|--|--|--|--|
| 1 | <p>Are you within, or close to, the known mapped range of any of the protected species OTHER THAN BATS which are potentially everywhere? Tick any that apply. See distribution maps in the Good Practice Guidance for each species -</p> <ul style="list-style-type: none"> <input type="checkbox"/> Dormice <input type="checkbox"/> Otters <input type="checkbox"/> Great crested newts <input type="checkbox"/> Sand lizards <input type="checkbox"/> Smooth snakes | <p>Name of Wood:</p> <hr/> <p>Grid Reference:</p> <table border="1" style="width: 100%; height: 20px;"> <tr> <td style="width: 25px;"> </td><td style="width: 25px;"> </td><td style="width: 25px;"> </td><td style="width: 25px;"> </td><td style="width: 25px;"> </td><td style="width: 25px;"> </td><td style="width: 25px;"> </td><td style="width: 25px;"> </td><td style="width: 25px;"> </td><td style="width: 25px;"> </td> </tr> </table> | | | | | | | | | | |
| | | | | | | | | | | | | |
| <p>YES</p> <p>NO</p> | | <p>Area: (ha)</p> <table border="1" style="width: 100%; height: 20px;"> <tr> <td style="width: 25px;"> </td><td style="width: 25px;"> </td><td style="width: 25px;"> </td><td style="width: 25px;"> </td><td style="width: 25px;"> </td><td style="width: 25px;"> </td><td style="width: 25px;"> </td><td style="width: 25px;"> </td> </tr> </table> | | | | | | | | | | |
| | | | | | | | | | | | | |
| 2 | <p>Does your wood contain any of the following habitats? Tick any that apply.</p> <ul style="list-style-type: none"> <input type="checkbox"/> Old trees with holes and crevices which might be used bats <input type="checkbox"/> Species rich scrub/coppice, early growth stage plantations and forest interfaces <input type="checkbox"/> Rivers on which otters might be found <input type="checkbox"/> Ponds which might be occupied by great crested newts <input type="checkbox"/> Open areas on heathy soils | <p>Date of Assessment:</p> <table border="1" style="width: 100%; height: 20px;"> <tr> <td style="width: 25px;"> </td><td style="width: 25px;"> </td><td style="width: 25px;"> </td><td style="width: 25px;"> </td><td style="width: 25px;"> </td><td style="width: 25px;"> </td><td style="width: 25px;"> </td><td style="width: 25px;"> </td> </tr> </table> | | | | | | | | | | |
| | | | | | | | | | | | | |
| <p>YES</p> <p>NO</p> | | <p>Name of Assessor:</p> <hr/> | | | | | | | | | | |
| 3 | <p>Have any of the protected species been recorded in this wood or on adjoining sites? Tick any that apply. Indicate which sources of information you have checked:</p> <ul style="list-style-type: none"> <input type="checkbox"/> National Biodiversity Network (www.nbn.org.uk) <input type="checkbox"/> Local Biological Records Centre <input type="checkbox"/> Local Wildlife Trust <input type="checkbox"/> Other <p><i>Specify Other:</i></p> | <p>YES</p> <p>NO</p> | | | | | | | | | | |
| 4 | <p>Have your inspections or any expert surveys found any of the following signs or evidence? Tick any that apply.</p> <ul style="list-style-type: none"> <input type="checkbox"/> Signs (e.g. otter spraint, nuts gnawed by dormice, leaves folded by newts) <input type="checkbox"/> Sightings (or echo-location) <input type="checkbox"/> Potential breeding or roosting sites (e.g. veteran trees, old trees with crevices, riverside hollow trees, ponds, timber stacks, large fallen deadwood) <input type="checkbox"/> Confirmed breeding or roosting sites (i.e. evidence of sites actually being used) <p><i>Details:</i></p> | <p>YES</p> <p>NO</p> | | | | | | | | | | |
| CHECK POINT | <p>If you have answered NO to ALL of the above then only bats need to be considered in your operations.</p> <p>If you have answered YES to any of the above then the species concerned must be considered as well as bats.</p> | | | | | | | | | | | |
| 5 | <p>Do the operations comply with Good Practice for bats and any other species found (or likely to be found in your wood) or can the operations be modified to do so? <i>Details: Use reverse of form to expand as required:</i></p> | <p>YES</p> <p>NO</p> | | | | | | | | | | |
| | | <p>A licence is not required but continue to sections 6 and 7 below</p> <p>You will need to obtain a licence BEFORE carrying out the work (see EPS Licence Application Forms and Notes)</p> | | | | | | | | | | |
| 6 | <p><u>Whether or not a licence is required...</u> Has the information been communicated to operators (including the location of breeding sites and sensitive areas)? Tick any that apply.</p> <ul style="list-style-type: none"> <input type="checkbox"/> Included in documentation (e.g. contract, letter of instruction, site assessment or other management plan) <input type="checkbox"/> Shown to operators and/or their supervisor <input type="checkbox"/> Marked with paint or hazard tape <input type="checkbox"/> Shown on the site plan <p><i>Other means:</i></p> | <p>YES</p> <p>NO</p> | | | | | | | | | | |
| | | <p>You may commit an offence if you do not tell your operators about the protected species in your wood.</p> | | | | | | | | | | |
| 7 | <p>Have arrangements for supervision been made to ensure Good Practice guidance is complied with during the operations? <i>Details:</i></p> | <p>YES</p> <p>NO</p> | | | | | | | | | | |
| | | <p>You may commit an offence if you do not take steps to ensure that your operators comply with the Good Practice guidance.</p> | | | | | | | | | | |

3. BS 5837:2012 Figure 2: Default specification for protective barrier

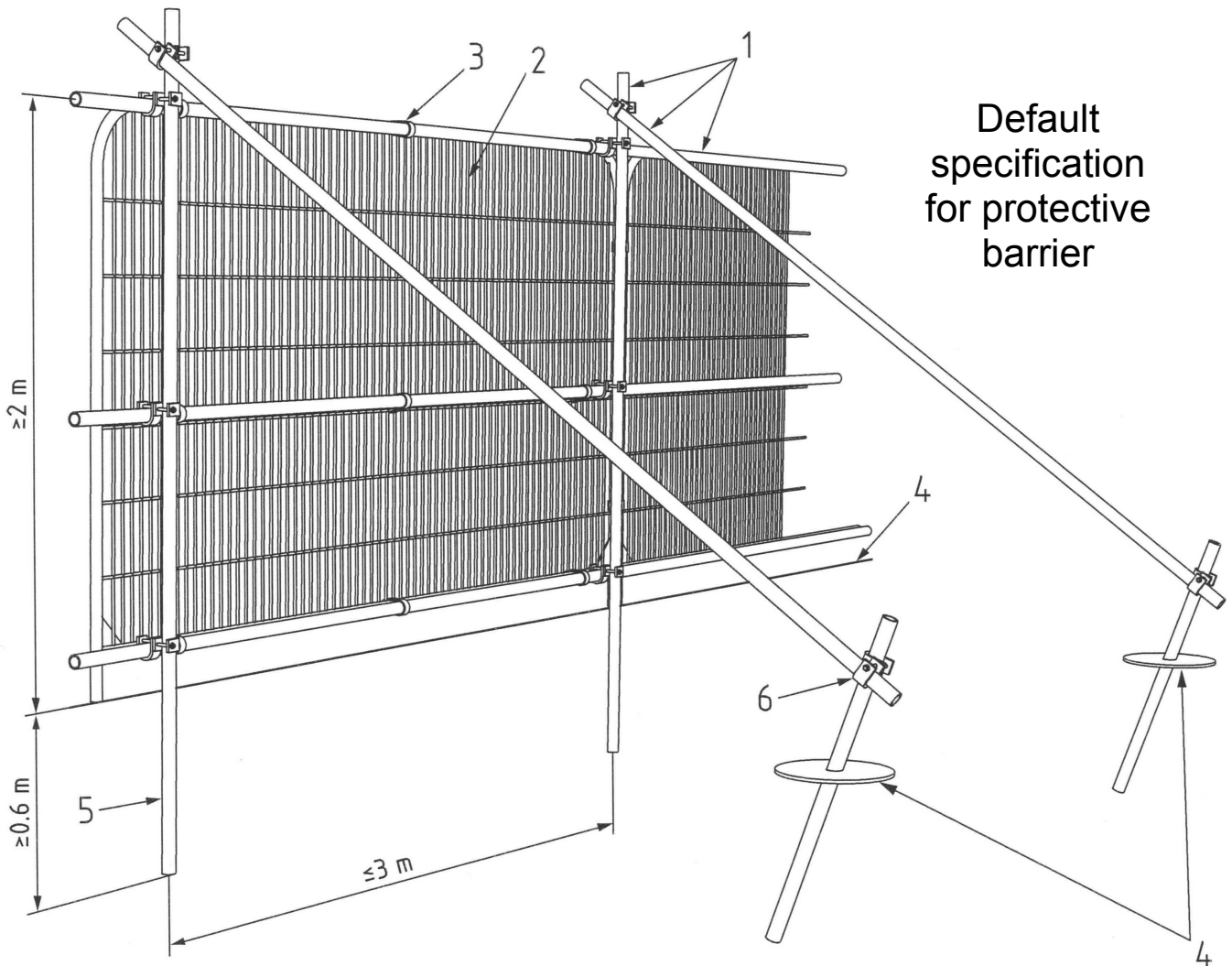

Default
specification
for protective
barrier

Key

- 1 Standard scaffold pole
- 2 Heavy gauge 2m tall galvanised tube and welded mesh infill panels
- 3 Panels secured to uprights and cross-members with wire ties
- 4 Ground level
- 5 Uprights driven into the ground until secure (minimum depth 0.6m)
- 6 Standard scaffold clamps

4. BS 5837:2012 Figure 3: Examples of above-ground stabilizing systems

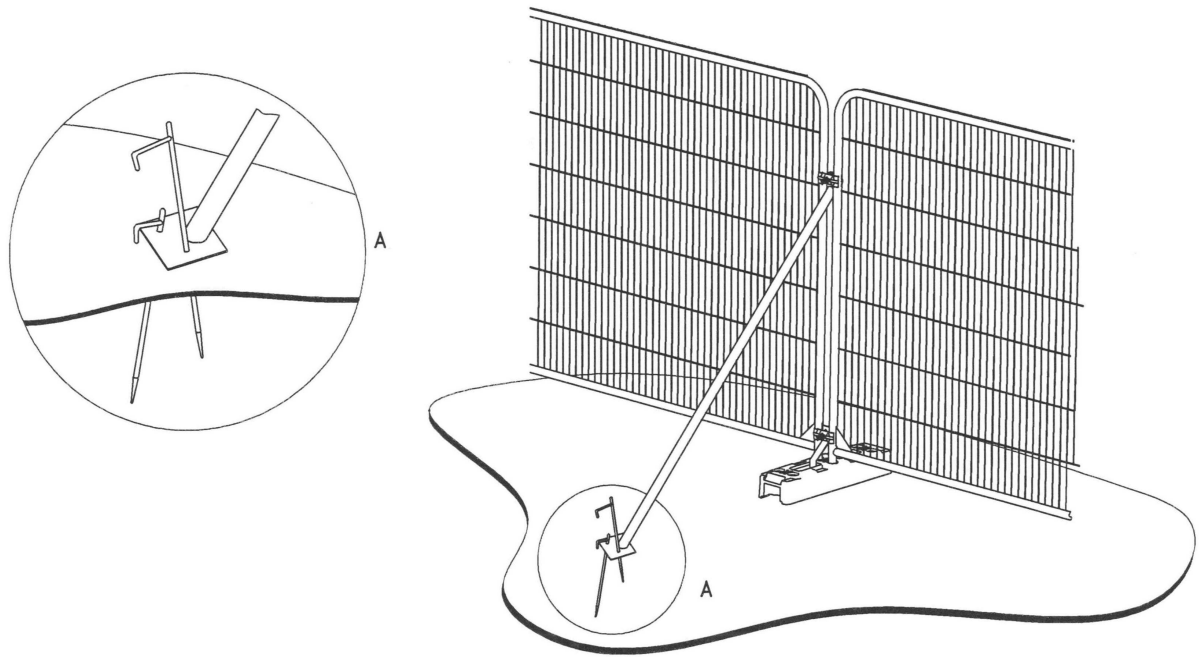

a) Stabilizer strut with base plate secured with ground pins

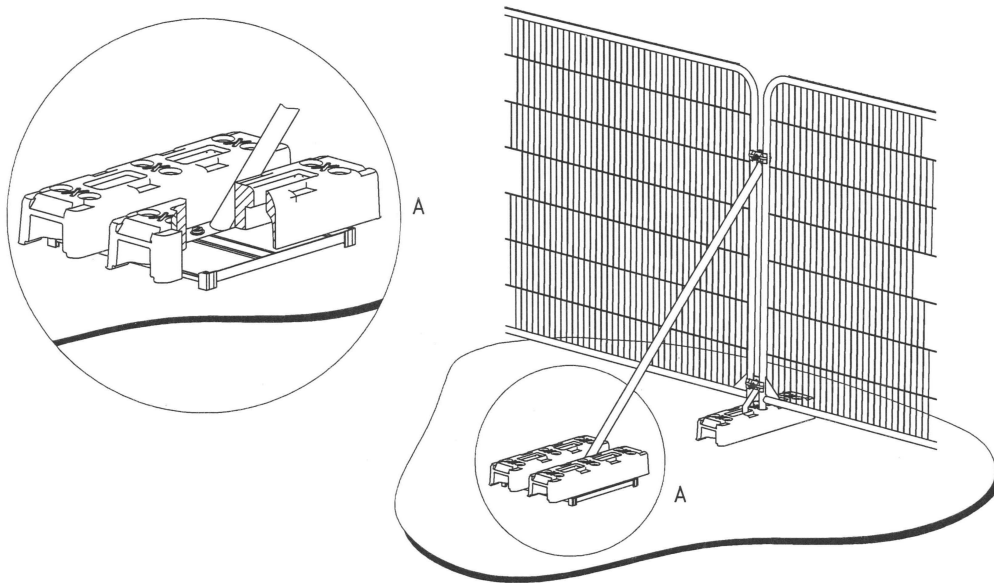

b) Stabilizer strut mounted on block tray

5. METHOD STATEMENT FOR “NO-DIG” CONSTRUCTION IN LINE WITH ARBORICULTURAL PRACTICE NOTE 12 “Through the Trees to Development”

Prior to commencing any demolition or construction on site, erect protective fencing around trees to form an exclusion zone (see attached plan).

This will ensure that roots will not be severed during the construction work and the soil in the area of the exclusion zone will not be compacted thus enabling oxygen to continue to diffuse into the soil beneath.

Construction of the driveway, path or other hard surface should be undertaken in dry weather between May and October when the ground is driest and least prone to compaction.

- 1 Kill ground vegetation using a translocated herbicide (glyphosate), ensuring that the selected herbicide doesn't damage the root of the tree(s) below the surface of the path.
- 2 Remove the dead or organic material from the site and ensure that large stones and shrub stumps are removed from the proposed route.
- 3 Any tree stumps should be ground out rather than excavated to minimize soil disturbance.
- 4 The resulting hollows and any other holes along the route driveway, path or other hard surface should be filled with sharp sand.
- 5 Lay *Terram Geotextile* matting across the full width of the driveway, path or other hard surface. This will prevent the intrusion of roots into the sub-base whilst still allowing nutrients and gaseous exchange.
- 6 Lay *Terram 150 Geocell* (cellular confinement system). (This is available from the Terram Ltd, tel: 01495 757722, fax: 01495 762393, and can be cut with a Stanley knife on site to the length, width and profile of the path required).
- 7 The driveway, path or other hard surface is to be supported against 150 x 20mm tanalised softwood boarding and 200mm long tanalised soft wood pegs driven into the ground at 1500mm centres.
- 8 Carefully push 20mm – 40mm gravel chippings (no fines) into the *Geo 150 Geocell* matting to form an aggregate sub-base.
- 9 The chippings should be placed at one end of the matting and pushed/spread across the matt to prevent compaction of the soil, working on either side of the driveway, path or other hard surface.
- 10 Compact the sub base to ensure binding with the *Geocell* and to minimise future wheel rutting.
- 11 Lay second layer of *Terram Geotextile* matting across the full width of the driveway, path or other hard surface. This will prevent the intrusion of fines into the gravel chippings.
- 12 Add layer of 'no fines, sharp sand and compact if using pavers as surface treatment.
- 13 Place proposed surface treatment (e.g. Pavers) on top of the compacted sub-base to form the finished surface to the path and 'bank up' the edging with topsoil, which is to be grass seeded in spring/autumn. This will form a gentle slope from the edging to the existing ground level.

- 1) Tanalised softwood pegs at 1500mm centres
- 2) Top soil banked up to edging
- 3) Softwood boards / Concrete edging 'tiles'
- 4) Existing surface to be cleared of ground vegetation using a translocated herbicide such as glyphosate

- 5) Geo-textile matting "Terram" laid on top of footpath
- 6) "Geocell" Cellular Confinement System (150mm deep) with gravel chippings
- 7) Geo-textile matting "Terram" laid on top of cellular confinement system
- 8) Gravel or paving laid on top of permeable sub-base

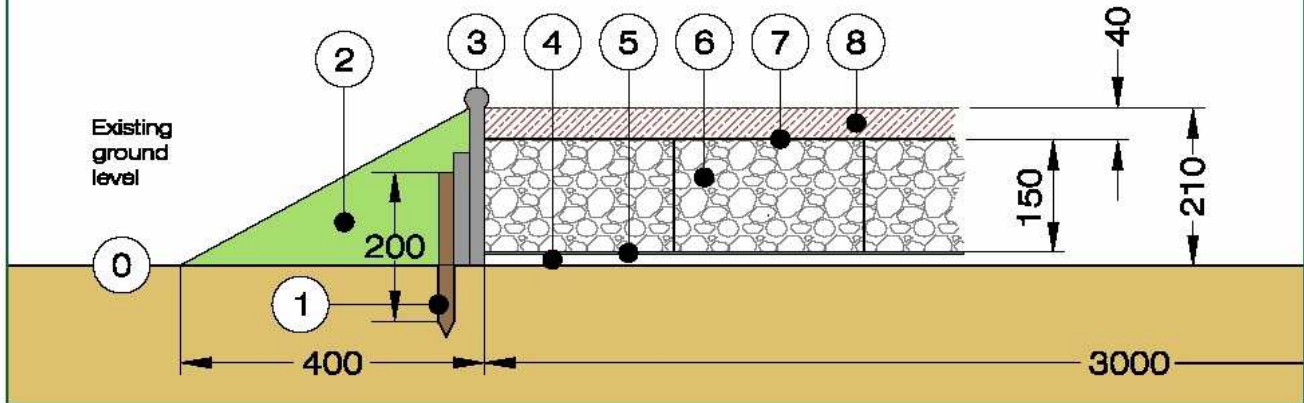

- 2) Top soil banked up to edging
- 3) Softwood boards / Concrete edging 'tiles'
- 4) Existing surface to be cleared of ground vegetation using a translocated herbicide such as "glyphosate"
- 5) Geo-textile matting "Terram" laid on top of footpath

- 6) "Geocell" Cellular Confinement System (150mm deep) with gravel chippings
- 7) Geo-textile matting "Terram" laid on top of cellular confinement system
- 8) 'No fines' sand laid on top of geo-textile matting
- 9) Aquaflo permeable paving laid on top of no fines sharp sand and permeable sub-base

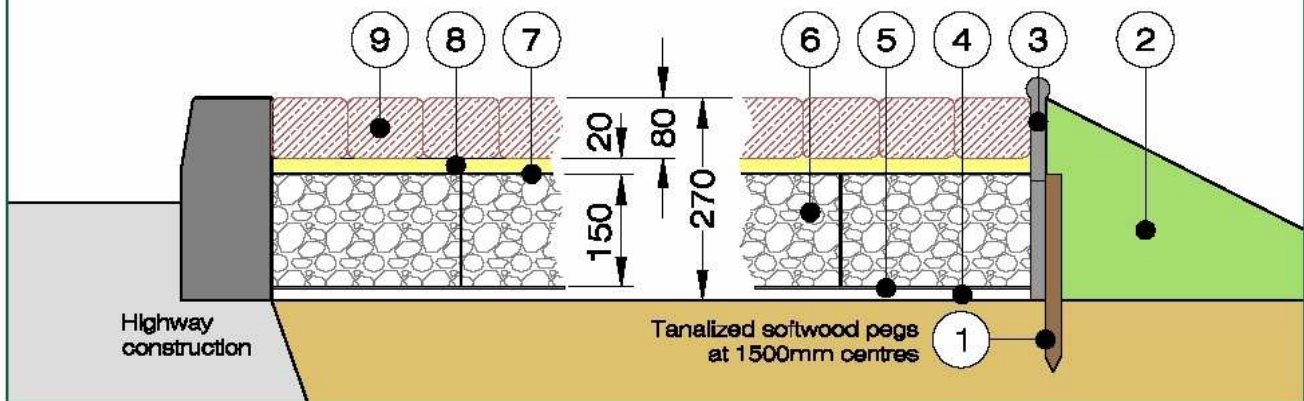

5 Moseley' Farm
Business Centre
Fornham All Saints
Bury St Edmunds
Suffolk IP28 6JY

Tel: 01284 765391
Fax: 01284 765181
Mob: 07850167400
info@treesurveys.co.uk
www.treesurveys.co.uk

© Hayden's 2011

'No Dig' Driveway & Parking Specification

Scale
1:10 (A4)

Drg No.
Hayden's.ND



**'No Dig' Footpath &
Driveway Specification**

- 2) Top soil banked up to edging
- 3) Softwood boards / Concrete edging 'tiles'
- 4) Existing surface to be cleared of ground vegetation using a translocated herbicide such as glyphosate
- 5) Geo-textile matting "Terram" laid on top of footpath
- 6) "Geocell" Cellular Confinement System (150mm deep) with gravel chippings
- 7) Geo-textile matting "Terram" laid on top of cellular confinement system
- 8) 'No fines' sand laid on top of geo-textile matting
- 9) Gravel or paving laid on top of permeable sub-base

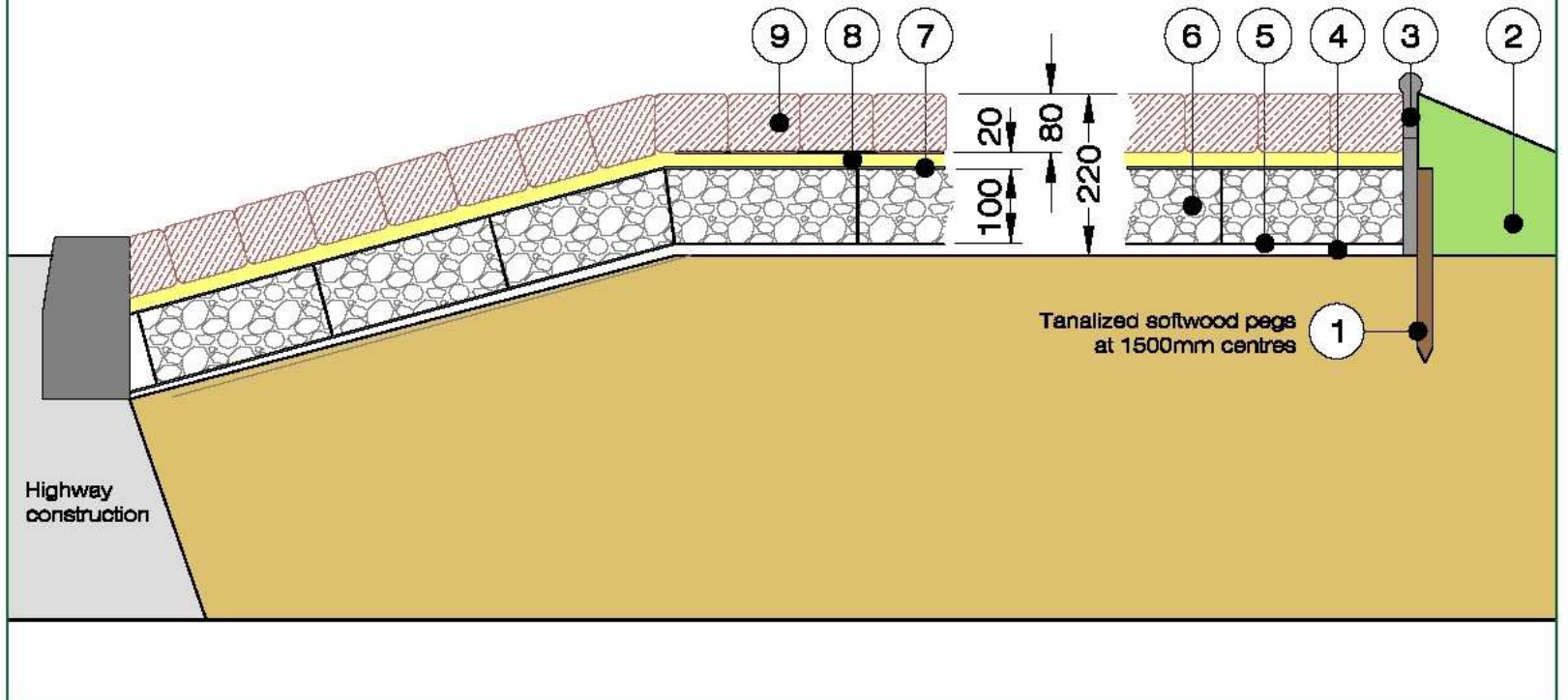

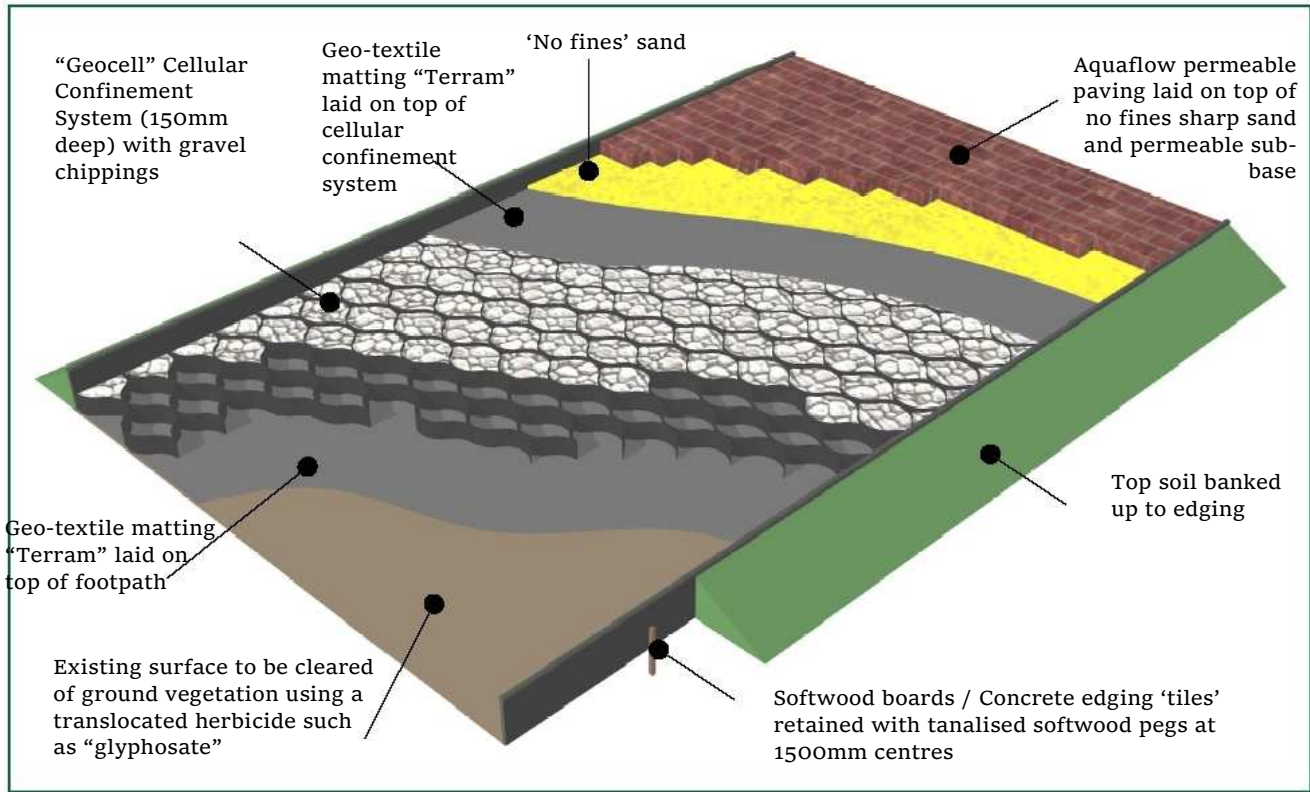

The 3D drawing above may not accurately depict the construction to be carried out and should be taken as indicative only. Use the section drawings on the previous page for full details on the required construction method

'No Dig' system during construction (right)

"Geocell" Cellular Confinement System (100mm deep) with gravel chippings (below)



HAYDEN'S
Arboricultural Consultants

5 Moseley' Farm
Business Centre
Fornham All Saints
Bury St Edmunds
Suffolk IP28 6JY

Tel: 01284 765391
Fax: 01284 765181
Mob: 07850167400
info@treesurveys.co.uk
www.treesurveys.co.uk

© Hayden's 2011

The Aquaflow® range of permeable paving

Aquaslab®

For use on Pedestrian areas

Size

300 x 450 x 60mm

Laying pattern

Staggered stretcher bond

Colours*

Natural, Burnt Red, Red brindle, Golden brindle and Charcoal

Finish

Standard

Bush hammered to special order

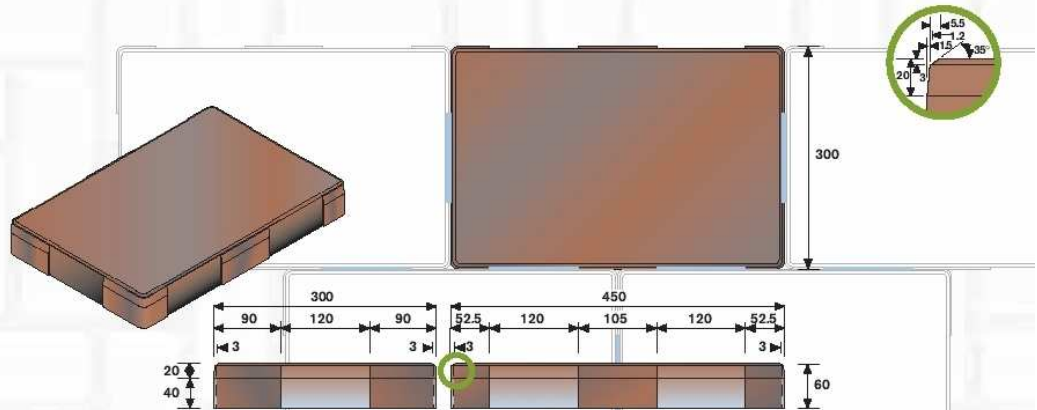

Aquasett®

For use on footpaths, domestic drives and roads (80mm)

Range of colours and the Olden finish make the Aquasett appropriate for use in conservation areas or on projects where architectural heritage is a major consideration.

Sizes

150 x 250 x 60/80mm

Laying pattern

Staggered stretcher bond or 90° herringbone for trafficked areas.

Colours*

Traditional, Red Brindle, Vendage and Pennant.

Finish

Olden

Bush hammered to special order

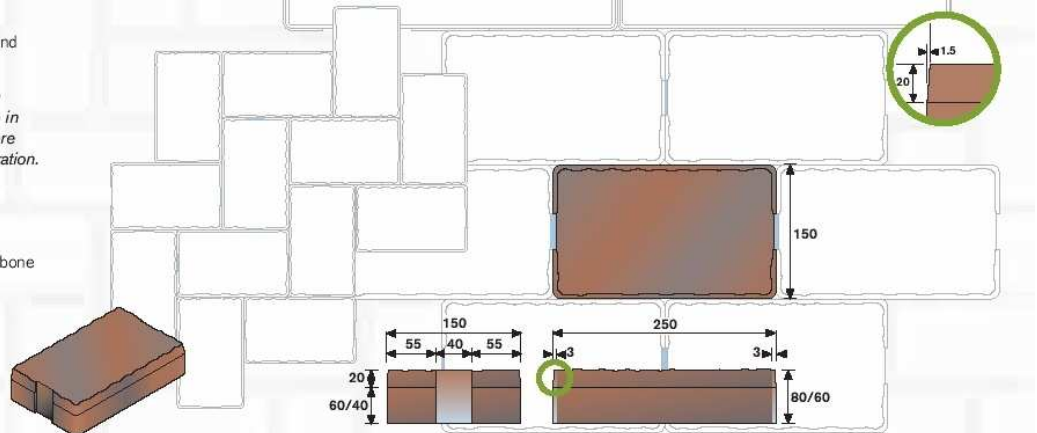

Aquasett combined®

For use on footpaths and domestic drives

Range of colours and the Olden finish make the Aquasett combined appropriate for use in conservation areas or on projects where architectural heritage is a major consideration

Sizes

Large 150 x 250 x 60/80mm

Medium 150 x 150 x 60/80mm

Small 100 x 150 x 60/80mm

Ratio of blocks in 0.8 square metre manufactured format: 10 large, 14 medium and 7 small.

Laying pattern

Staggered stretcher bond

Colours*

Traditional, Red Brindle, Vendage and Pennant.

Finish

Olden

Bush hammered to special order

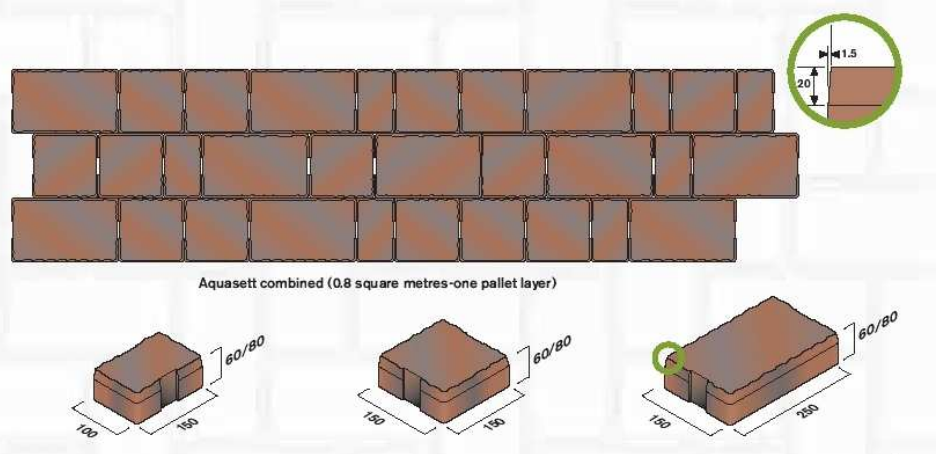

Formpave have designed a range of Aquaflow paving blocks to be used in conjunction with either tanked or infiltration systems.

The range consists of six blocks manufactured from concrete with a tensile splitting strength in accordance with BS EN 1338:2003.

Included within the range is the Aquaslab which has been designed for use on non-trafficked pedestrian areas.

All of the blocks and slabs provide drainage through vertical channels and will allow water through the surface at a rate of approximately 9000mm per hour (9000 litres per m² per hour). The Inbitex geotextile beneath the laying course will allow approximately 4500 litres per m² per hour through and this figure should be used for design purposes.

The Aquaflow ML block system consists of an interlocking block with specialist top, bottom and edge blocks and has been specifically designed for heavy duty applications.

The ML blocks can be laid by hand or by machine. Where the blocks are machine laid modules of .65m² are laid in one pass. Laying rates of over 600m² per day have been readily achieved with a three man crew.

• Other colours and finishes such as EcoGranite are available to special order.

Aquaflow block®

For use on car parks, drives and moderately trafficked areas

Sizes

100 x 200 x 60/80mm

Laying pattern

Must be laid in 90° herringbone

Colours*

Natural, Burnt Red, Red brindle, Golden brindle and Charcoal.

Finish

Standard

Bush hammered to special order

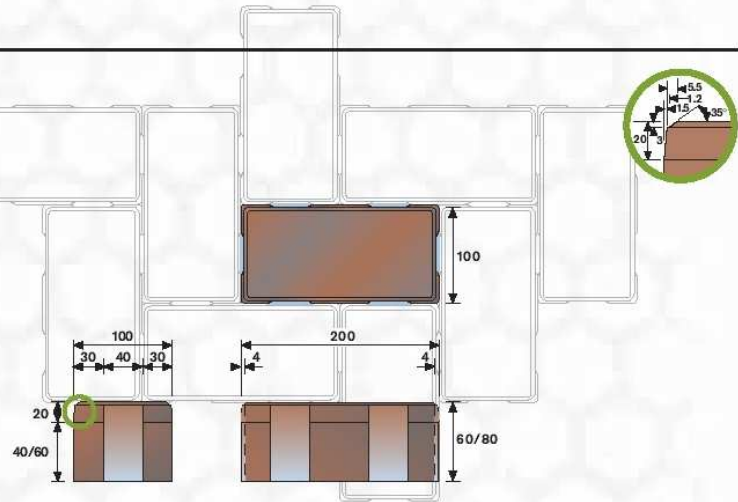
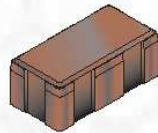

Aquaflow ML block®

For Roads and heavy duty use

Size

80mm

Laying pattern

Include stretcher course around edge in conjunction with MLE and MLTB

Colours*

Natural, Burnt Red, Red brindle, Golden brindle and Charcoal.

Finish

Standard

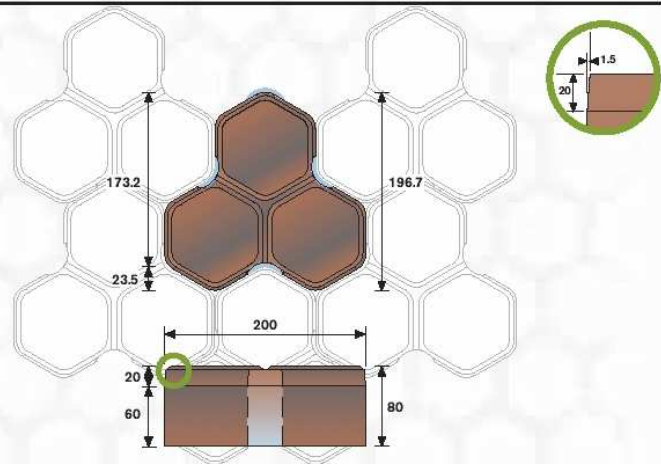
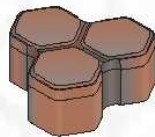

Not available in EcoGranite

Aquaflow MLE® top drawing

End block

For use with Aquaflow ML blocks

Aquaflow MLTB® bottom drawing

Top and bottom block

For use with Aquaflow ML blocks

Size

80mm

Colours*

Natural, Burnt Red, Red brindle, Golden brindle and Charcoal.

Finish

Standard

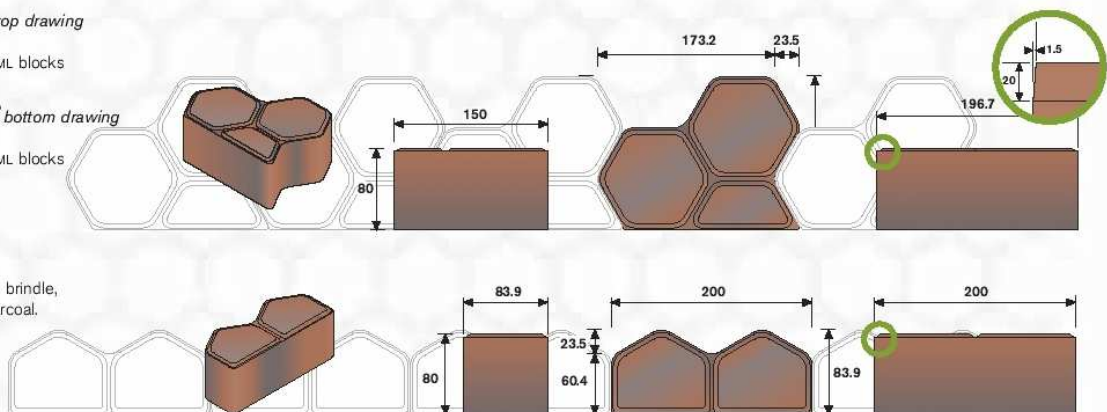

Not available in EcoGranite

The logo for TERRAM, featuring the word "TERRAM" in a bold, white, sans-serif font on a dark blue rectangular background with a white curved underline on the left side.

Terram Cellular Confinement System
For the protection
of tree roots

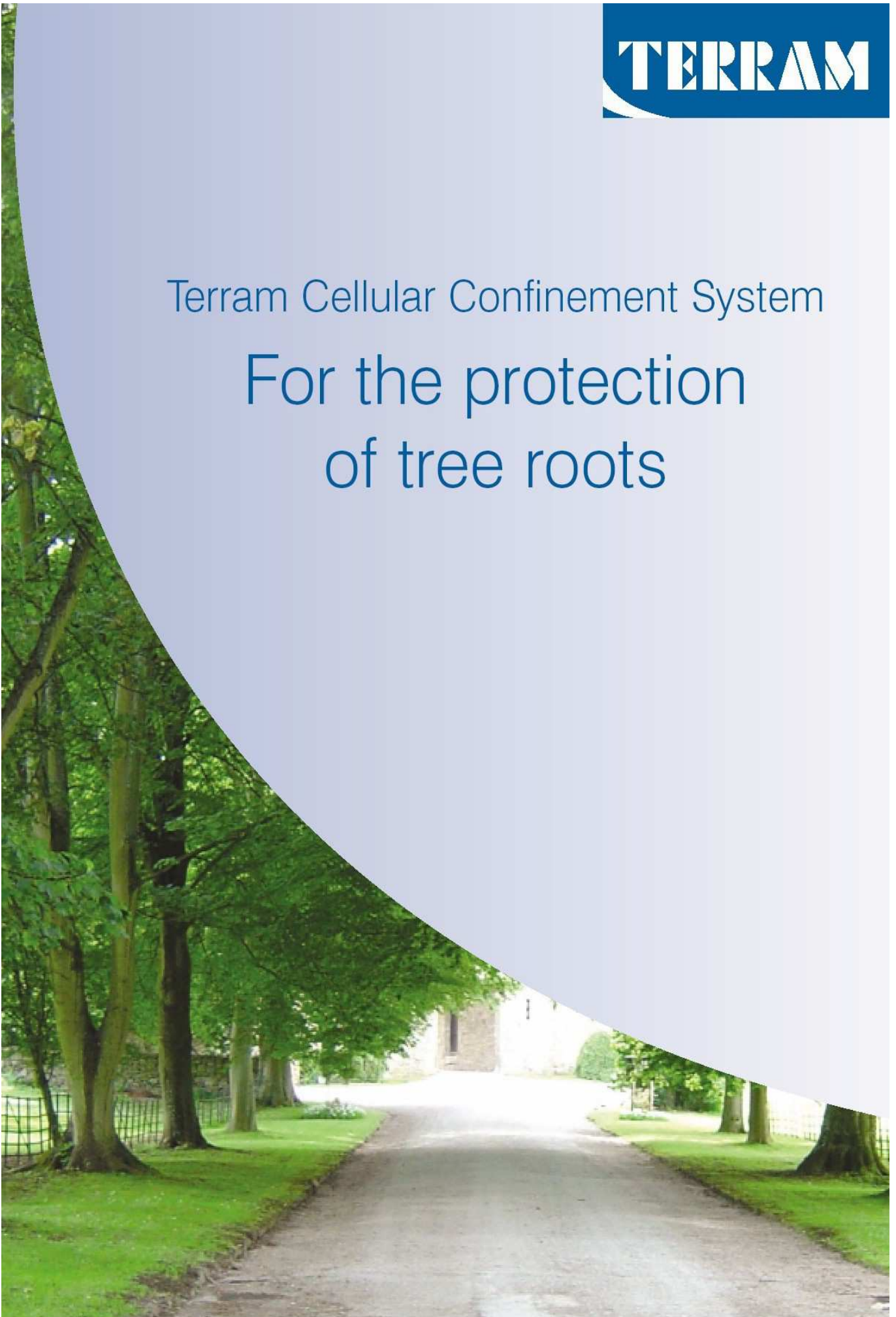

Cellular Confinement Systems

The perfect no-dig ground reinforcement system.
 Provides above-ground load bearing for paths and driveways
 whilst preventing soil compaction and protecting tree roots.

Damage to tree roots during driveway construction

The conventional method for constructing paths, drives and roads involves excavating soil to enable the installation of a sub-base that will adequately support traffic loads. Unfortunately this method of construction can badly damage trees since a by-product of the excavation is root severance. Most people don't realise that trees are very sensitive to disturbances in the soil around them. The reason for this is that, contrary to popular belief, trees do not have massive roots that go deep down into the soil but rather have lots of relatively small roots (frequently only a few centimetres in diameter) which spread out from the tree very close to the soil surface for quite large distances (often equal to the height of the tree).



If you imagine a tree system as a wine glass standing on a dinner plate you will have a roughly accurate idea of the above and below ground proportions of a tree (Figure 1). It may come as a surprise to learn that about 80-90% of all tree's roots are in the upper metre of soil (Figure 2). These roots serve two purposes: anchorage and absorption of moisture. If even relatively small roots are severed, for example by digging a trench, the tree can begin to suffer symptoms of drought stress as it is no longer able to obtain all its water needs. In addition the tree may become unstable as cutting the roots is a bit like cutting the guy roots on a tent.

Figure 1

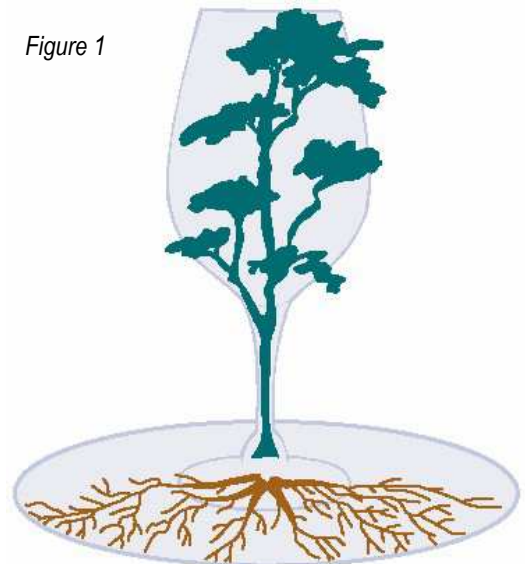

It is not only root severance that may harm trees but also compaction of the soil. If the root zone of a tree is not protected during development then the soil may become compacted by vehicles or heavy machinery moving repeatedly over the ground (Figure 3). The effect of compaction is to close up pores in the soil which contain air and water. The tree's roots then suffer from both a lack of oxygen and a lack of moisture, and, as the soil becomes denser, roots find it hard to penetrate the soil. All this can lead to a dieback of the root system and frequently dieback of the tree. Raising of soil levels has a similar damaging effect as it deprives roots of oxygen and creates a build up of harmful carbon dioxide around the roots.

So, How Do Tree Roots Grow?

People often wrongly assume that tree roots are thick and grow down into the soil for many metres (Figure A). In reality tree roots:

- Are usually only large near to the trunk and get thinner the deeper and further from the tree they go. At a distance of just 3-4 metres from the trunk most roots are no bigger than a few centimetres in diameter.
- Spread outwards from the trunk, more or less parallel with the soil rather than growing downwards (Figure B).
- Can spread horizontally in any direction for a distance equivalent to at least the tree's height.
- Are usually relatively shallow; 80-90% of a tree's roots are in the Upper metre of soil. Few roots reach depths of more than about 2-3 metres and at this depth they are only a few millimetres in diameter.

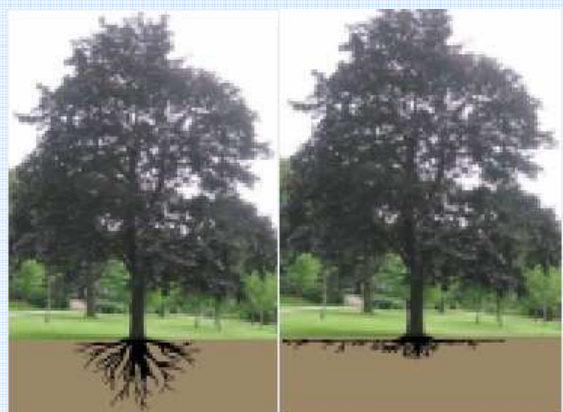

Figure A: Incorrect

Figure B: Correct

British standard for trees in relation to construction and APN1

In recognition of the fact that trees are sensitive to disturbance the British Standards Institution has published recommendations on how to protect trees during development. In line with the earlier British Standard (BS 5837: 1991) the most recent guide, published in September 2005 (see further reading), recommends that there should be a 'root protection area' in which development should not be permitted.

In most case this are has a radius equal to twelve times the trunk diameter and forms a exclusive zone around the tree protected by means of robust fencing. This guidance had the effect of prohibiting the installation of roads, driveways and parking areas near to trees. But in 1996 the Arboricultural Advisory and Information Service published Arboricultural Practice Note 1 Driveways Close to Trees (APN1) which suggested that driveways could be installed within the root protection area provided roots and soil were not damaged.

The conditions set out for a suitable system were as follows:

- Roots must not be severed
- Soil should not be compacted
- Free movement of oxygen and carbon dioxide into and out of the soil should be maintained
- Water infiltration into the soil should not be impeded

The, APN1 advised that driveways could be installed within the root protection zone provided that an above-ground, no-dig construction was used. This advice was incorporated into the recent British Standard which recommended that the most effective means of achieving this was through the use of a three-dimensional cellular confinement system.

Terram Geocell ground protection

Terram Geocell is an ideal solution for providing ground reinforcement with tree protection areas. It confines fill material within its strong flexible cell structure in order to provide a stable base for traffic and an even load distribution (Figure 3 and 4). A big advantage of Terram Geocell over other products is that the geotextile material is permeable and allows lateral movement of air and water.

Terram Geocell is suitable for permanent woodland trails, paths, driveways, roads and parking areas.

It may also be used as temporary ground reinforcement where access to a site is limited by the presence of trees. Once operations on site are completed the temporary surface can easily be removed and the ground left undamaged.

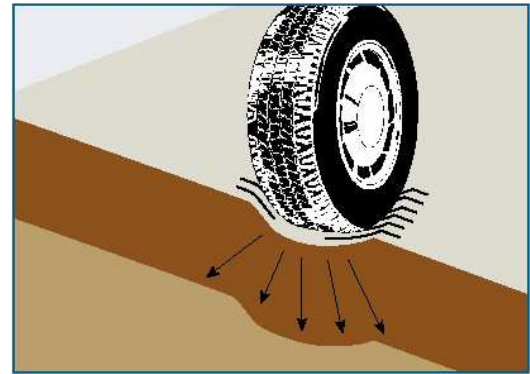

No ground reinforcement: Unreinforced soil becomes compacted and rutted by vehicle loads

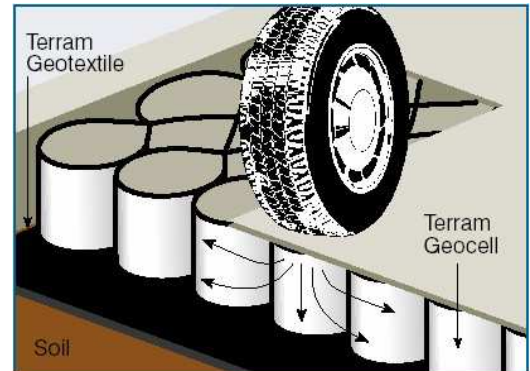

Geocell ground reinforcement: Forces are spread laterally reducing loads on the underlying soil

Figure 3. The Geocell Distributes loads evenly in order to prevent rutting

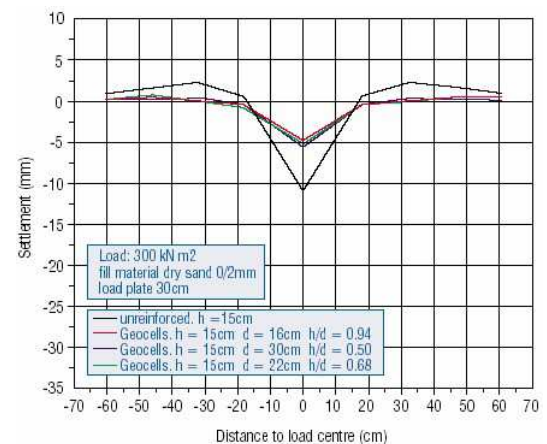

Figure 4. Static loading tests of up to 300kN/m2 revealed only minimal deflection (<5mm) of the surface of filled Geocell



Getting the design right

Every application will be slightly different so it is important to have the input of an engineer and arboriculturist together in order to design the right solution for an installation near to trees. The Arboriculturist will be able to advise on tree protection issues and the engineer will be able to specify details such as cell depth, fill type (Figure 5) and load bearing capacity.

For example, the design of a pedestrian footpath may be less rigorous than that of an access road that may have to withstand the load of a heavy crane or lorry.

But there are some principles that should be considered in every application (see Figure 6):

- The ground must be protected at all stages during installation – there is no point in installing a ground protection system where soil or roots have already been damaged by other site activities
- Terram Geotextile should be used underneath the Geocell to prevent fill materials penetrating the soil
- The fill material should be granular and should permit water and air flow
- Any edgings should be carefully designed to avoid excavation and root severance
- A permeable and gas-porous wearing course should be installed above the Geocell
- In most cases the driveway or parking area should not exceed 20% of the root protection area.

If correctly designed and installed the Geocell cellular confinement system should allow paths, drives and parking areas to be located within a tree's protection zone, thus enabling development that might not otherwise be permitted by local authorities.

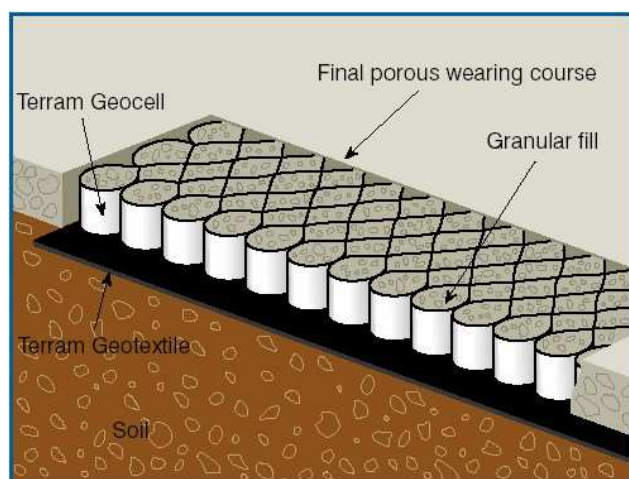

Figure 6. Components of an above-ground load bearing platform suitable for vehicles

Example installation Driveway construction

- 1 Remove grass and other vegetation and the upper organic layer of soil by hand digging. Arisings should be wheel-barrowed out of the tree protection area. Machinery (even low ground pressure tracked vehicles) should not be used due to the danger of soil compaction
- 2 Small depressions may be filled with sharp sand
- 3 Lay out Terram Geotextile over the driveway area
- 4 Lay out Terram Geocell and carefully peg in place
- 5 Fill the cells working from the area furthest from the trees first. Further filling should be carried out using the filled Geocell as a platform
- 6 Install a permeable wearing course, e.g. porous tarmac, block pavements on a sharp sand base (a further layer of Terram above the filled Geocell will be needed in this case to prevent the sand mixing with the granular fill below).

Conclusion

BS5837 Trees in Relation to Construction and APN1 allow the careful development of paths, drives and roads within the root protection area of trees provided an above-ground, no-dig construction is used.

The use of Terram Geocell as a ground reinforcement Platform is therefore an ideal solution that can facilitate such development near to trees which might not otherwise be permitted due to fears of damage to soil structure and tree roots.

Further reading

BS 583: 2005 *Trees in relation to construction – Recommendations*. British Standards Institution.

Dobson, M. (1995): *Tree Root Systems*. Arboriculture Research and Information Note 130/ARB/95. Arboricultural Advisory and Information Service, Farnham.

Patch, D. and Dobson, M. (1996). *Driveways Close to Trees*. Arboricultural Practice Note 1. Arboricultural Advisory and Information Service, Farnham.

Nicholson, R. (2001). APN1, BS5837 & PPG 3, *Guidance for Trees: Conflict or Complement?* Arboricultural Journal 25, 361-376.

| Products Available | Panel size | Depth | Cell Diameter |
|--------------------|--------------|-------|---------------|
| Erocell 22/20 | 5.0m x 10.1m | 200mm | 220mm |
| Erocell 25/15 | 7.0m x 10.0m | 150mm | 250mm |
| Erocell 25/10 | 7.0m x 10.0m | 100mm | 250mm |

The cell depth and diameter is dependent upon specific site conditions

Cellular Confinement Systems 1 June 2006

Terram Ltd, Mamhilad, Pontypool, Gwent NP4 0YR, United Kingdom
Tel: +44 (0) 1495 757 722 Fax: +44 (0) 1495 762393
Email: info@terram.co.uk Web: www.terram.com

Recommendations for use are a guide and purchasers must determine the suitability of the product for their intended use. Terram Ltd assumes no liability for claims beyond the replacement value of the product.

The instructions contained here are a general guide only and therefore cannot cover all aspects involved or all possible uses of Terram Cellular System. If you are not experienced in carrying out projects of the type Terram Cellular System is designed for, you should seek advice from someone appropriately qualified. Any recommendations or suggestions (including design guidance) given by or on behalf of Terram on the use of its products for particular applications are given in good faith and (unless otherwise agreed) free of charge, but it remains your responsibility to ensure the use is appropriate and the product correctly installed. Terram, its agents and employees, accept no responsibility for guidance or advice given. Terram guarantees that this product is in accordance with its specification and if not Terram will at its option supply replacement product or reimburse the price paid for it. This states Terram's entire liability, all other liability and responsibility is excluded. THIS DOES NOT AFFECT THE STATUTORY RIGHTS OF A CONSUMER.

6. MultiTrack Ground Guards Specification



MultiTrack

THE UNBREAKABLE ORIGINAL



RAPID INSTALLATION

Lay approximately 50 mats per hour.*

TOUGH

Virtually indestructible HDPE polymer supports all vehicle types.

EASY TO HANDLE

Lightweight 39kg mats easily handleable with two workers.

MULTI-TREAD

Roadway, Walkway and Smooth tread options cater for various vehicular and pedestrian needs.

ENVIRONMENTALLY FRIENDLY

Made from 100% recycled plastic and fully recyclable.

GUARANTEED UNBREAKABLE

Lifetime guarantee against breakage by vehicles up to 120 tonnes (T&Cs apply).

**NO CRANES OR
SPECIALIST
LIFTING
EQUIPMENT
NEEDED!**

***FAST, EASY, ECONOMICAL**
*Install approximately 50 mats
per hour with a team of
3 plus forklift driver.*

www.ground-guards.co.uk

+44 (0) 113 267 6000

info@ground-guards.co.uk

Ground-Guards®



MultiTrack

THE UNBREAKABLE ORIGINAL



Watch this short video to see MultiTrack in action.



MultiTrack mats are the strongest in their category



Mats are easily moved using a HandHook



Standard no-tools joiners quickly clip the mats together



Low profile joiners for walkways plus standard joiners



SafeStore stillages hold 25 mats

Material: Special blend of HDPE recycled plastic, fully recyclable

Overall Size: 2435 x 1215 x 13mm (plus treads)

Surface Area: 2.95m²

Weight: 39kg

Tread Options: Roadway, Walkway and Smooth, or a combination

Connectors: 10 joining points. A choice of standard clip joiners, low profile joiners or bolted joiners, plus anchor pins

Packed in: Stillage of 25 mats

Stillage Pack: **Weight:** 1105kg

Dimensions: 2550 x 1260 x 900mm

Fire Rating: UL94 HB

Slip Testing: BS7976 part 2

Deflection: Tested on varying CBR ground conditions using a 300mm diameter steel platen with 6 tonnes load to simulate the pressure of an HGV wheel

Ground CBR 11.35%: Deflection 17.68mm

Ground CBR 8.58%: Deflection 20.41mm

Ground CBR 4%: Deflection 22.00mm

Guarantee:

MultiTrack temporary roadway mats are guaranteed for life against breakage up to 120 Tonnes UDL (Uniformly Distributed Load).

It is the user's responsibility to assess the load-bearing capacity of the ground, and to only operate vehicles within the weight that the ground is capable of safely supporting. Ground-Guards Ltd accepts no liability whatsoever for any damage, loss or injury arising from the ground conditions on which these products are used.

MultiTrack mats are not suitable to use for bridging purposes. Damage caused by mechanical equipment (e.g. cuts by digger buckets) or sharp protrusions beneath the mats is not covered by this guarantee.

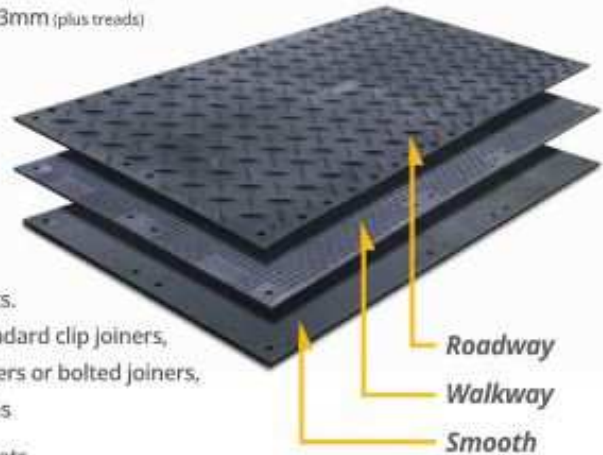

Ground-Guards

www.ground-guards.co.uk
+44 (0) 113 267 6000
info@ground-guards.co.uk

Appendix H

Drawing no. 7757-D-AIA Rev A

Appendix I

Drawing – plan/flank elevation sketches of garden study

Andrea Cincotta
XUL Architecture
33 Belsize Lane
London
NW3 5AS

CC: Mr and Mrs Fulford

E: kwmf@kwmfulford.com; jane.fulford1@btinternet.com;
a.cincotta@xularchitecture.co.uk

28 October 2019

Dear Andrea, Bill and Jane

Re: **Reconstruction of Garden Study**

16 Downshire Hill, NW3

Please see attached plan and flank elevation sketches.

The idea is to cause zero disturbance to the existing slab which then frees us from any unusual construction liability that mitigates tree and roots.

The slab simply becomes a support for the lightweight timber structure which is to be built on an insulated joisted floor.

We can use 3 no. piers founded by 60x60x60 concrete pads in the ground to bring the structure forward. I am guessing that there will be approximately 1.5 – 1.8m in front of the existing slab meaning that at least 60% of the structure weight will be borne by the slab (it's light anyway) in which case the 60x60x60cm pad should be perfectly sufficient. I have chosen pads and beam rather than a wall set on a strip foundation in order to minimise any potential root disturbance caused by excavation.

Yours sincerely

Murray Miel

*** All prices subject to VAT ***

PART OF METROPOLITAN PROJECT MANAGEMENT LTD

Registered Office. 1 Kings Avenue, Winchmore Hill, London, N21 Registered in England No.09367436

Downslope Hill Garden Study Plan View Sketch

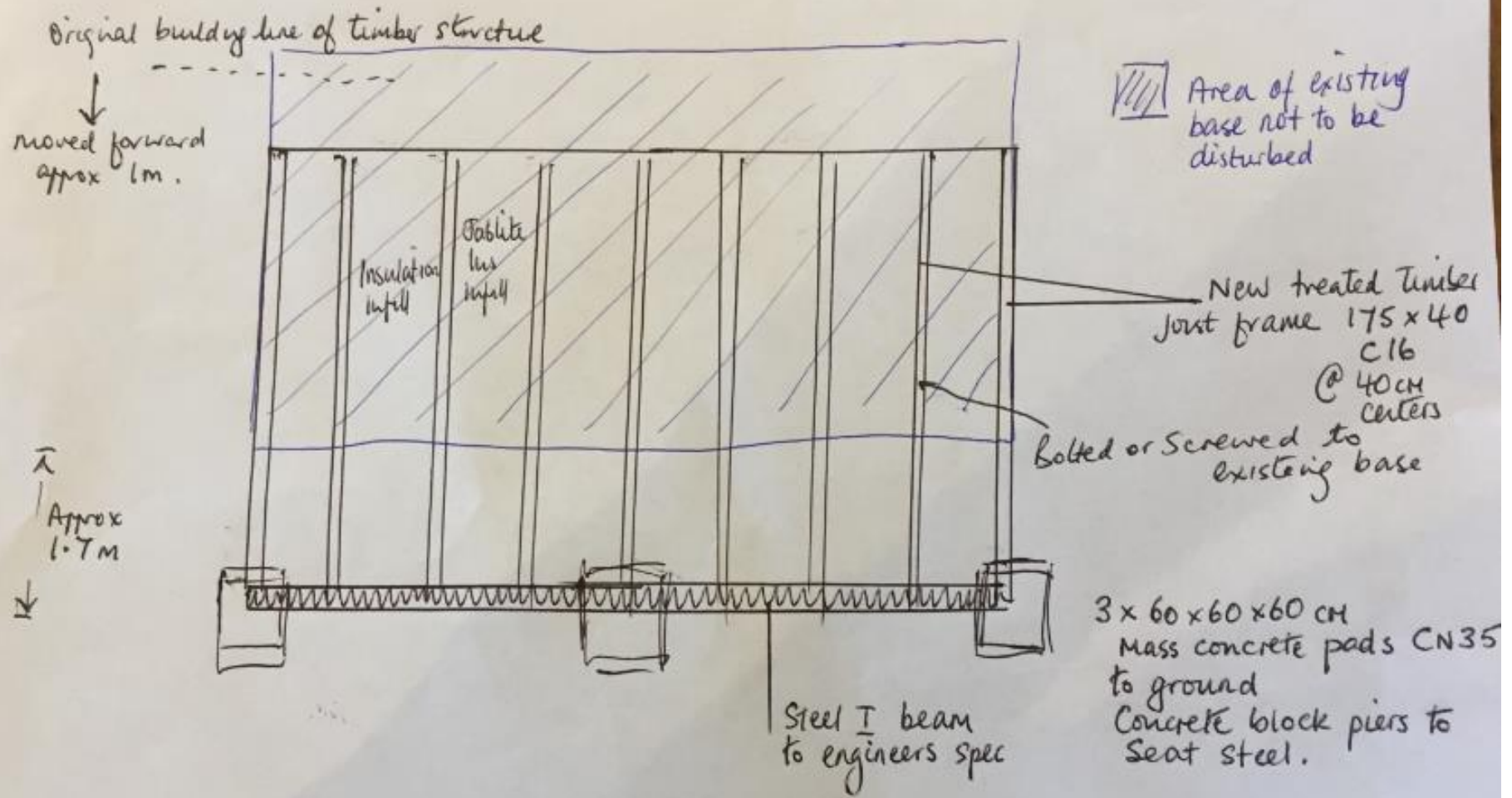

16 Downshire Hill, Proposed reconstruction of Garden Study.

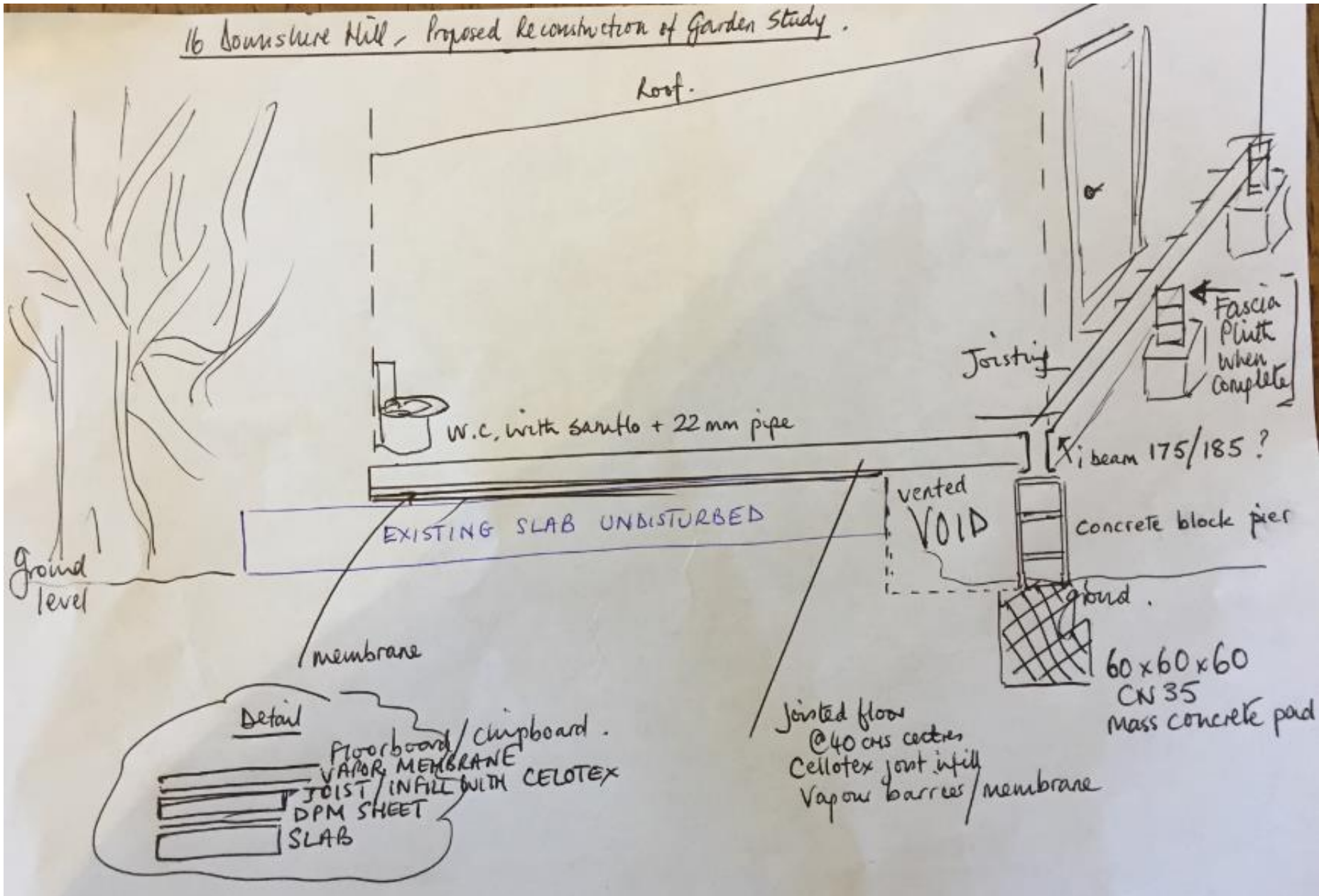

- Arboricultural Impact Assessments ●
- Arboricultural Method Statements ●
- Tree Constraints Plans ●
- Arboricultural Feasibility Studies ●
- Shade Analysis ●
- Picus Tomography ●
- Arboricultural Consultancy for Local Planning Authority ●
- Quantified Tree Risk Assessment ●
- Health & Safety Audits for Tree Stocks ●
- Tree Stock Survey and Management ●
- Mortgage and Insurance Reports ●
- Subsidence Reports ●
- Woodland Management Plans ●
- Project Management ●
- Ecological Surveys ●



Telephone
01284 765391
Email
info@treesurveys.co.uk
Website
www.treesurveys.co.uk

5 Moseley's Farm
Business Centre
Fornham All Saints
Bury St Edmunds
Suffolk
IP28 6JY