



Rely on it.

RENOLIT ALKORPLAN F

Mechanically fastened system



EXCELLENCE
IN ROOFING

Mechanically fastened system

Product information

RENOLIT ALKORPLAN F₃₅₁₇₀

Calendered/laminated unreinforced membrane of flexible PVC. Conforms to UEAtc guidelines.

RENOLIT ALKORPLAN F₃₅₁₇₆

Calendered/laminated membrane of flexible PVC with woven polyester reinforcing. Conforms to UEAtc guidelines.

Application

Used as waterproofing membrane within mechanically restrained systems.

RENOLIT ALKORPLAN F₃₅₂₇₆ for the RENOLIT ALKORBRIGHT concept

Calendered/laminated membrane of flexible PVC with woven polyester reinforcing, white in the mass and provided with a transparent protection layer. High quality product which stands for durable and extra high reflection.

CE approval.

Certificats available on our website

www.alkorproof.com.

0679-CPD-0156 (ETAG 006)

0679-CPD-0157 (ETAG 006)

0679-CPD-0171 (EN 13956)

0679-CPD-0172 (EN 13956)

Product data	Method	Requirements according to UEAtc	Average production values				Units
			RENOLIT ALKORPLAN F ₃₅₁₇₀ 1.5 mm	RENOLIT ALKORPLAN F ₃₅₁₇₆ 1.2 mm 1.5 mm		RENOLIT ALKORPLAN F ₃₅₂₇₆ 1.5 mm	
Tensile strength	EN 12311-2 (A)	L ≥ 800	-	1286	1298	1251	N/50 mm
		T ≥ 800	-	1270	1203	1196	N/50 mm
	EN 12311-2 (B)	L ≥ 15	16.8	-	-	-	N/mm ²
		T ≥ 15	16.3	-	-	-	N/mm ²
Elongation at break	EN 12311-2 (A)	L ≥ 15	-	18	19	18.1	%
		T ≥ 15	-	21	21	19.9	%
	EN 12311-2 (B)	L ≥ 250	349	-	-	-	%
		T ≥ 250	371	-	-	-	%
Dimensional stability (6h at 80 °C)	EN 1107-2	≤ 0.5	-1.6	-0.15	-0.10	-0.16	%
		≤ 0.5	-0.9	-0.03	-0.03	-0,04	%
Cold track temperature	EN 495-5	-20	-25	-25	-25	-25	°C
Tear strength	EN 12310-1	L ≥ 150	-	543	603	574	N
		T ≥ 150	-	581	608	598	N
	EN 12310-2	L	97	247	257	248	N/mm
		T	108	242	243	244	N/mm
Lamination strength	EN 12316-2	≥ 80	137	178	143	179	N/50 mm
Water vapour diffusion resistance (μ)	EN 1931		15 000	15 000	15 000	15 000	-
Resistance to static perforation	EN 12730	-	20	20	20	20	L

Size/Weight	Thickness	Width	Weight	Roll length	Roll weight
RENOLIT ALKORPLAN F ₃₅₁₇₀	1.5 mm	1.05 m	1.95 kg/m ²	20 lm	ca. 39 kg
RENOLIT ALKORPLAN F ₃₅₁₇₆	1.2 mm	1.05 m	1.53 kg/m ²	25 lm	ca. 40 kg
	1.2 mm	1.60 m	1.53 kg/m ²	20 lm	ca. 52 kg
	1.5 mm	1.05 m	1.85 kg/m ²	20 lm	ca. 41 kg
	1.5 mm	1.60 m	1.85 kg/m ²	15 lm	ca. 47 kg
RENOLIT ALKORPLAN F ₃₅₂₇₆	1.5 mm	1.05 m	1.85 kg/m ²	20 lm	ca. 41 kg

Standard conditions of sale are included in price lists, all sales of RENOLIT products are made under these conditions. RENOLIT ALKORPLAN is delivered in rolls. Every delivery may contain up to 10% of short rolls (minimum length: 8 m).

Storage

Store dry. Rolls to be parallel and in original packing where possible, do not stack in cross form or under pressure.

Mechanically fastened system

Application instructions for RENOLIT ALKORPLAN membranes, mechanically fastened into metal deck, wood or concrete. For other substrates, please seek advice and guidance from the technical dept. of RENOLIT.

Metal deck (warm roof)

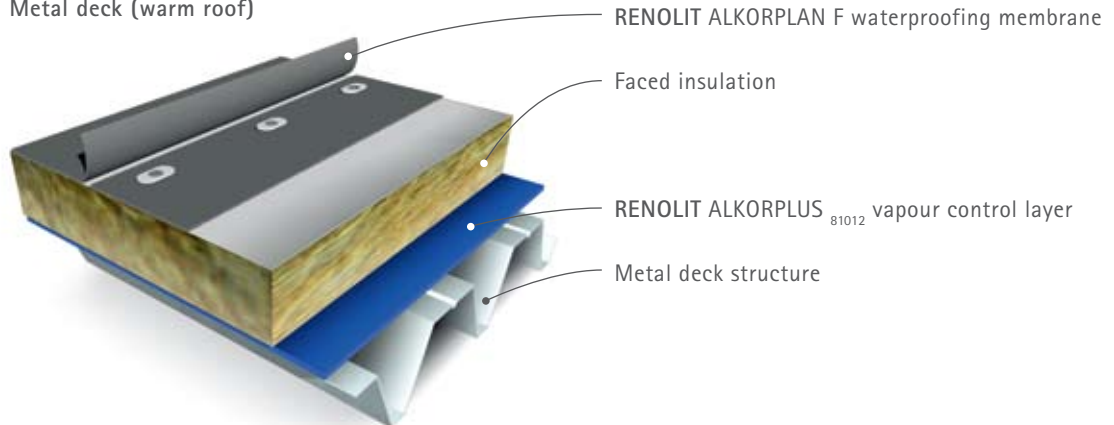

Concrete (warm roof)

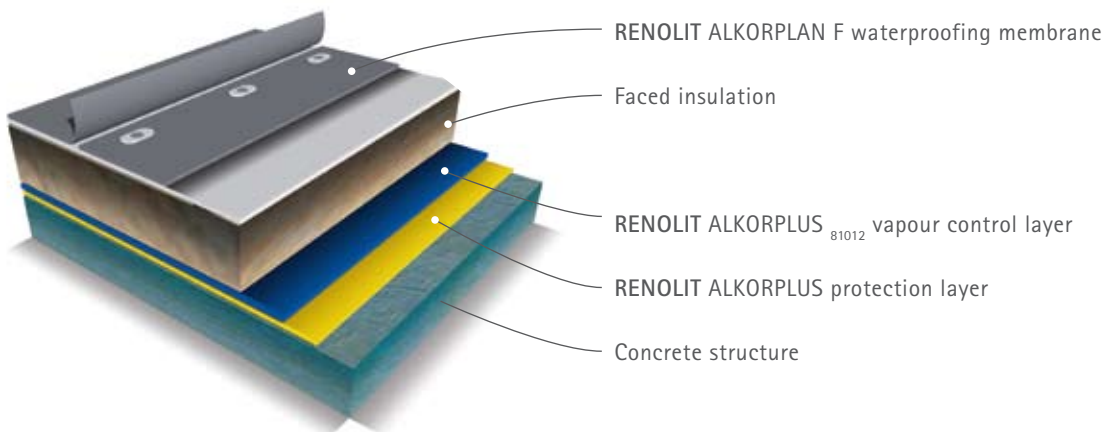

Timber (warm roof)

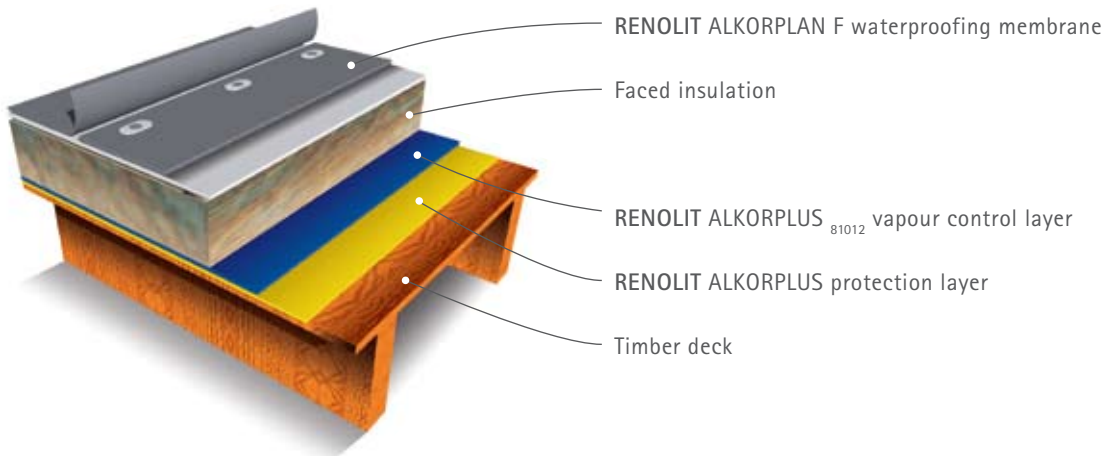

Roof construction

Structure

Before the waterproofing membrane is installed, the roof deck has to be free of irregularities, water, frost, ice and debris such as screws, metal off-cuts, etc.

• Metal deck

The minimum thickness for metal deck to be used with mechanical fasteners is 0.7 mm according BS EN 10147:2000. All construction work is carried out according to current requirements (BS 5950) and design criteria.

Quality:

- Galvanised Steel: S320 G or 350 G (2/21) according to BS EN 10326
- Alu -zinc according to BS EN 10214 (5%) or EN 10215 (55%)
- Stainless steel 14301 or 14401 according to EN 10088

• Concrete roof deck

A concrete supporting structure should comply with the minimum quality BS 8110 part 1 1985 and I.S.326:1995. The surface is to be smooth without protrusions or irregularities over 2 mm (ideally power floated).

• Timber structure

The minimum thickness of the supporting structure will be:

- wood: 25 mm (tongued and grooved)
- plywood (exterior quality): 19 mm (preferably 22 mm) this must conform to the relevant requirements of BS EN 636 and BS 5268.
- OSB 3: 18 mm according to BS EN 300.

Any treatment should be compatible with the components and the chosen method of attachment of the insulation or single ply membrane. The supporting elements are installed and fixed to obtain a closed deck surface where all vertical movement is excluded. Height or thickness tolerances between panels must not exceed 3 mm. The installation of the supporting timber structure must comply with the local building regulations.

Protection layer

On rough surfaces or wooden structures, a RENOLIT ALKORPLUS protective layer is used to ensure that damage does not occur to the RENOLIT ALKORPLAN membrane or the vapour control layer. Protective layers are loosely laid with a 50 mm overlap. Refer to table 1.

Vapour control layer

Condensation can occur on the underside of the membrane during cold periods. The membrane has a reasonable level of vapour permeability so this condensate will disperse in a period of warmer weather. If higher humidity exists in a building there may be a build up of condensation in the construction which will not be fully removed in the drying

periods. Depending on the predicted interior climate in the building and the hygrometric characteristics of the roofing materials, a vapour control layer may be required.

The RENOLIT ALKORPLUS₈₁₀₁₂ LDPE vapour control layer is available in the standard version. The vapour control layer is laid with an overlap of 100 mm and taped with RENOLIT ALKORPLUS₈₁₀₅₇ adhesive tape. When the joint is fully supported it must be hand rolled together to secure to the tape. The vapour control layer is laid parallel with the crowns of the metal deck and the overlap seams will occur above the crown of the deck and the joint sealed by use of pressure. If the substrate is anything other than a metal deck (concrete, OSB, plywood or timber), then the direction of installation of the vapour control layer is not critical. The vapour control layer is taken up and sealed to details and all penetrations in accordance with Part L1 of the UK Building regulations.

RENOLIT also has a self-adhesive vapour control layer available. The RENOLIT ALKORPLUS₈₁₀₀₂ vapour control layer is a self-adhesive membrane, which is based on an aluminium film, barrier to vapour, and a self adhesive bitumen-based glue layer.

Insulation

Insulation boards must be approved by the respective manufacturer for use with RENOLIT ALKORPLAN membranes. The insulation is installed in accordance with the manufacturers' guidelines. The compressive strength must be adequate for mechanical fastening with a minimum of 0.06 N/mm² at 10% compression (according to BS EN 826). On metal decks, the dimensions and thickness of the insulation boards must suit the dimensions of the metal deck profile.



Saab (UK)

Roof construction

Separation layers

If **RENOLIT ALKORPLAN** membranes are laid over unfaced polystyrene or polyurethane, a **RENOLIT ALKORPLUS** separation layer (glass fleece 120 g/m² or polyester fleece 180 g/m²) must be employed. (See table 1). On a bituminous surface, a **RENOLIT ALKORPLUS**₈₁₀₀₅ polyester fleece 300 g/m² is always required. The separation layers are loose laid with a 50 mm overlap. When using an insulation board with a facing of aluminium foil, the **RENOLIT ALKORPLUS** separation layer is not required. If in doubt, please refer to the **RENOLIT** technical department for further advice.

Application as:	Separation layer	Protective Layer
RENOLIT ALKORPLUS ₈₁₀₀₁ glass fleece, 120 g/m ²	on unfaced PUR or PS insulation	-
RENOLIT ALKORPLUS ₈₁₀₀₅ fleece PES, 300 g/m ²	on bitumen, unfaced PUR or PS insulation	on rough surfaces
RENOLIT ALKORPLUS ₈₁₀₀₈ fleece PES, 180 g/m ²	on unfaced PUR or PS insulation	-

table 1: **RENOLIT ALKORPLUS** separation and protective layers

RENOLIT ALKORPLAN membrane

The **RENOLIT ALKORPLAN** membrane is rolled out, free of tension, on top of the insulation or separation layer at 90° to the deck direction. Where the substrate is not metal deck (concrete, OSB, plywood or timber) the direction of the membrane is not critical. Mechanical fasteners (screws and plates) are installed through the membrane and insulation into the crowns of the deck. (See fig 1.) The adjoining sheet is aligned to the first one with an overlap of 100mm minimum. A line is printed on one side of the membrane to facilitate this. The quantity of fasteners is calculated to resist wind uplift in the central and perimeter roof area in accordance with current guidelines (calculation according to UK standards BS 6399-2).

A minimum distance of 150 mm between fasteners is observed at all times. this may require the use of a narrower membrane in order to obtain the correct quantity of fasteners per m² with a minimum of 2/m². A test weld must be carried out prior to welding the roofing sheet, to confirm adequate weld strength and performance. The **RENOLIT ALKORPLAN** membrane is welded preferably by hot air, or by solvent, using **RENOLIT ALKORPLUS**₈₁₀₂₅ welding fluid. The welded area must be continuous and extend a minimum of 30mm from the membrane edge. End laps must be staggered by 250mm, thus preventing a situation where 4 roll ends coincide. Where 3 membranes overlap, the centre sheet must be chamfered.

After completion of the welding, weld security is verified by drawing a metal probe along the joint in a firm but non-destructive way. Finally, liquid **RENOLIT ALKORPLAN**₈₁₀₃₈ seam sealer is applied to the edges of all welded seams. To ensure satisfactory adhesion of the liquid **RENOLIT ALKORPLAN**₈₁₀₃₈ this operation must be carried out as work progresses.

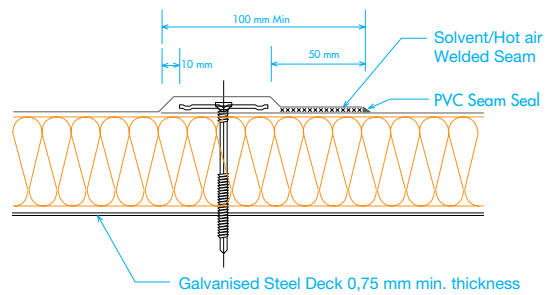

fig. 1: mechanical fixings and overlaps



fig. 2: Verification of weld security



Folleli Theatre (France)

Mechanical fastening

Fastener type

The type and length of fasteners are determined by the:

- type of structure
- insulation thickness

Taking into account these parameters, a number of fasteners can be used. A summary is given in table 2. Minimum distance between fasteners is 150 mm, maximum distance between fasteners is 475 mm.

Please contact **RENOLIT** in case of the use of 2.10 m wide **RENOLIT ALKORPLAN F₃₅₁₇₆***

Design Value (N/fastener)	
Metal deck In case of RENOLIT ALKORPLAN F 35176 take into account a design value of 500 N. This value is based on a winduplift test according to ETAG 006 guidelines using the following formula: $W_{adm} = W_{test} \times C_a \times C_d / \gamma_m$ W _{adm} = design value W _{test} = test value C _a = geometrical correction factor C _d = statistical correction factor γ _m = security factor = 1,5	
Gas concrete (min. quality CC3/500) Width 1.05 m	Please contact the RENOLIT Technical Dpt.
Concrete (min. quality B25) Width 1.05 m	Please contact the RENOLIT Technical Dpt.
Timber Width 1.05 m	Please contact the RENOLIT Technical Dpt.

table 2: Design values

- For refurbishment on metal deck thinner than 0.7 mm, a lower pull-out value will be used. The **RENOLIT** Technical Department will be happy to supply more information.
- On concrete or wood, a static pull-out test should be performed to verify the deck quality.
- A minimum of 2 fasteners/m² is required at all times.
- For end laps a minimum of 2 fasteners/lm is required.
- The distance between fasteners must be maintained at regular intervals.
- the fasteners must comply with ETAG 006

(* Please contact **RENOLIT** for other suppliers or other types of screws/plates.

Supplementary fixing

Edge restraint is installed along the perimeter of the roof and around all penetrations. Special attention is paid to the wind-tight installation of parapets.



fig. 3: Edge restraint with **RENOLIT ALKORPLAN 81170** or **81171** metalsheet

Edge restraint

RENOLIT ALKORPLAN metal sheet **81170** or **81171** is preformed to obtain a minimum width of 70 x 70 mm for an L-shaped profile. (See fig. 3) These profiles are pre-fixed to the supporting deck. The maximum distance between fixings is 250 mm with fixings on one face only of the **RENOLIT ALKORPLAN** metal sheet and in zig-zag formation to resist a continual tensile load of 2.7 kN/lm. If **RENOLIT ALKORPLAN** metal profiles are fixed in the vertical leg, fasteners will be at 200mm distance. Should the roof have valleys which have angles less than 174°, it will be necessary to include Alkormetal sections of 140 mm girth, fixed at 250 mm centres.



Olympic Centre (Poland)

Mechanical fastening

Windtight installation to parapet details

• With a RENOLIT ALKORPLUS₈₁₀₅₈ compressive foam strip underneath the RENOLIT ALKORPLAN metal sheet trim, the parapet top is sealed against wind pressure. (See fig. 4) The membrane is protected from an abrasive upstand surface by a RENOLIT ALKORPLUS₈₁₀₀₅ protective layer (min. 300 g/m²). Where the parapet height exceeds 500 mm, intermediate support with a continuous RENOLIT ALKORPLAN metal sheet (50 mm wide) is required.

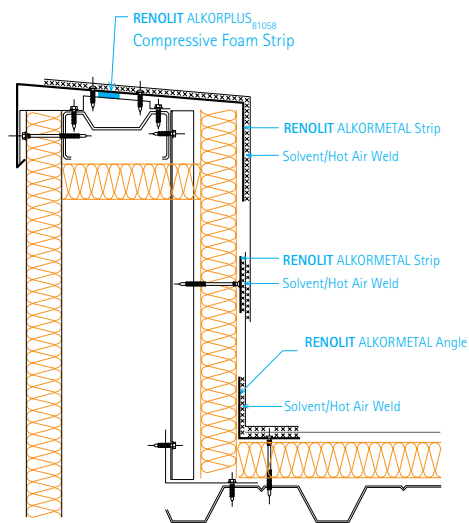

fig. 4: RENOLIT ALKORPLUS₈₁₀₅₈ compressive foam strip

• Parapets can also be adhered to achieve a wind-tight detail. (See fig. 5) Here, the RENOLIT ALKORPLUS₈₁₀₄₀ contact glue is applied to the entire surface of both membrane and upstand with a minimum consumption of 2 x 150 g/m². The parapet will have a RENOLIT ALKORPLUS metal trim, but compressive foam and intermediate fastening can be omitted.

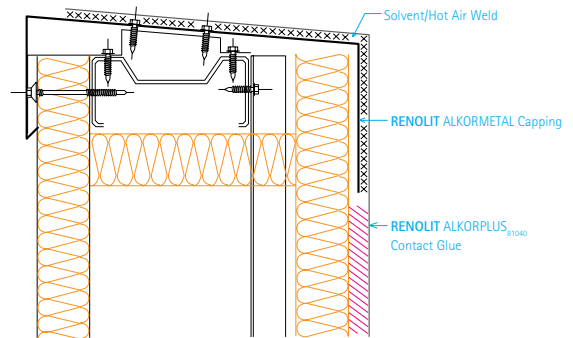

fig. 5: Double-sided gluing of parapets

Execution of details

See Design Manual.

General remarks

Slope

BS 6229 states that a minimum finished fall at any point of 1:80 should be achieved. Cut-to-falls systems are often produced to a 1:60 fall or 1:40 fall.

Compatibility

Contamination of RENOLIT ALKORPLAN membranes by oil, petrol and other solvents, hot or cold bituminous products, tar, etc. must be avoided as these will attack the PVC polymer, damage the appearance and reduce the life expectancy of the products. For a list of chemical resistance with a number of substances, a summary table is available. (See brochure «Chemical stability»). RENOLIT ALKORPLAN membranes must not be brought into contact with RENOLIT ALKORFLEX, RENOLIT ALKORTOP or RENOLIT ALKORTEC membranes. Wood in contact with RENOLIT ALKORPLAN membranes should only be treated with salt-based products to avoid adverse effects. Under no circumstances should solvent-based preservatives be used.

Other remarks

The following rules and regulations must be respected at all times:

- BBA, UEAtc, IAB
- Irish Building regulations 1997 to 2002
- BS 6229 1982 flat roofs with continuous supported coverings.
- The Building Act 1984 and its Building regulations 2000
- SPRa design guide for single ply roofing.
- All other current norms and directives.
- The product information and instructions for execution of particular details issued by RENOLIT concerning RENOLIT ALKORPLAN and RENOLIT ALKORPLUS products.
- The installation and safety instructions issued by manufacturers or suppliers of associated materials and accessories used in the construction of the roof.
- Water outlets and other details are duly fixed to the structure.
- ETAG 006

The information contained in the present commercial literature has been given in good faith and with the intention of providing information. It is based on current knowledge at the time of issue, and may be subject to change without notice. Nothing contained herein may induce the application of our products without observing existing patents, certificates, legal regulations, national or local rules, technical approvals or technical specifications or the rules and practices of good workmanship for this profession. The purchaser should verify whether import, advertising, packaging, labelling, composition, possession, ownership and the use of our products or the commercialisation of them are subject to specific territorial rules. He is also the sole person responsible for informing and advising the final end user. When faced with specific cases or application details not dealt with in the present guidelines, it is important to contact our technical services, who will give advice, based on the information at hand and within the limitations of their field of expertise. Our technical services cannot be held responsible for the conception of, nor the execution of the works. In the case of negligence of rules, regulations and duties on the part of the purchaser we will disclaim all responsibility. The colours respect the UV resistance required by EOTA, but are still subject to the natural change over time. Are excluded from the guarantee: aesthetic considerations in case of partial repair of deficient membrane covered by the guarantee.

WWW.ALKORPROOF.COM



The British Board of Agrément have assessed the life expectancy of RENOLIT ALKORPLAN F used in the United Kingdom to be in excess of 30 years.



RENOLIT ALKORPLAN roofing products and system have a standard guarantee of 10 years, and are installed by approved contractors and installers who are trained and assessed by RENOLIT.



All RENOLIT waterproofing membranes for roofing are part of the ROOFCOLLECT collection and recycling programme.



The RENOLIT division responsible for the roofing activity has been approved to EN ISO 9001:2008.



RENOLIT (UK) Cramlington Ltd, Station Road
Cramlington, Northumberland NE23 8AQ - United Kingdom
T +44 1670 718283 - F +44 1670 590096 - renolit.cramlington@renolit.com

LAYDEX Ltd. - Unit 3 - Allied Industrial Estate - Kylemore Road - Dublin 10
T +353(0) 1 642 6600 - F +353 (0) 1 642 6601 - sales@laydex.ie

LAYDEX (NI) Ltd. - Units 4 & 5 Falcon Way - Belfast BT 12 6 SQ
T + 44 (0) 2890 382 223 - F + 44 (0) 2890 382 230



Rely on it.