

Existing Rear Elevation

Proposed Windows

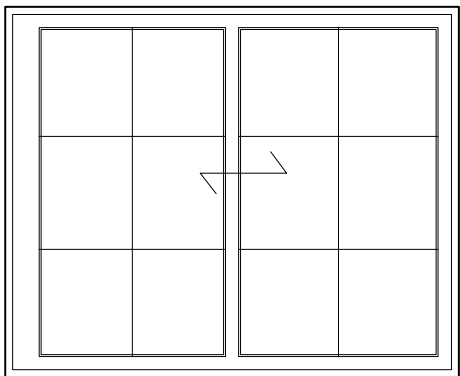

E Timber Slimline Sliding Sash

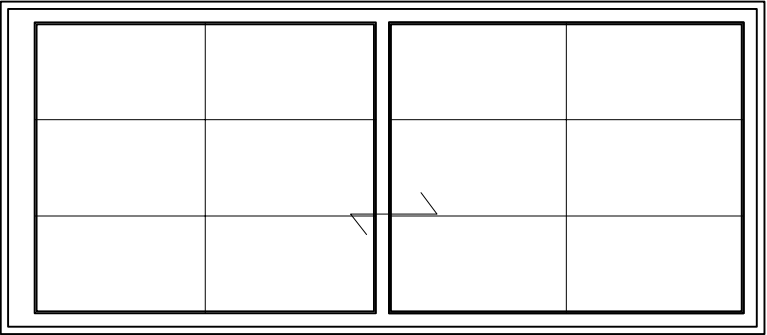

F Timber Slimline Sliding Sash

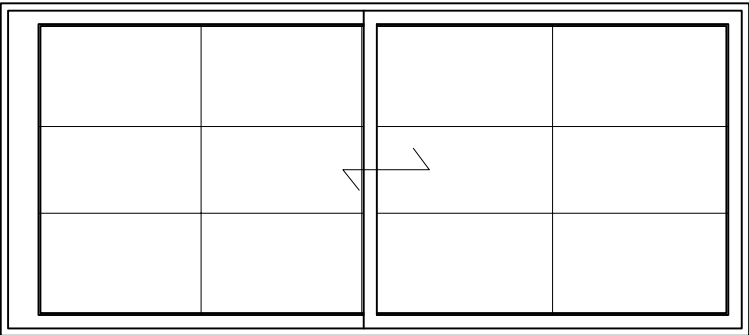

G Timber Slimline Sliding Sash

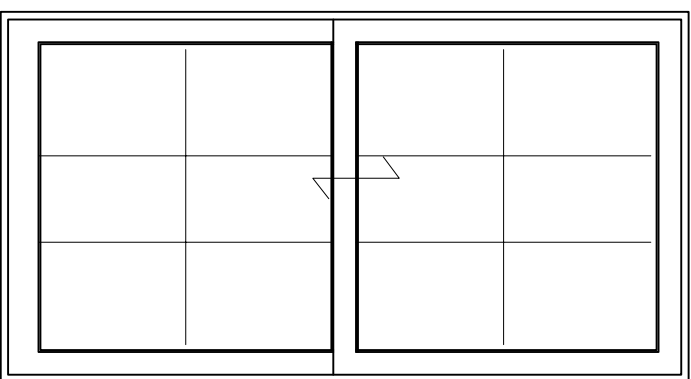

H Timber Slimline Sliding Sash

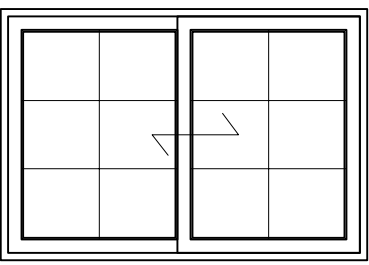

I Timber Slimline Sliding Sash

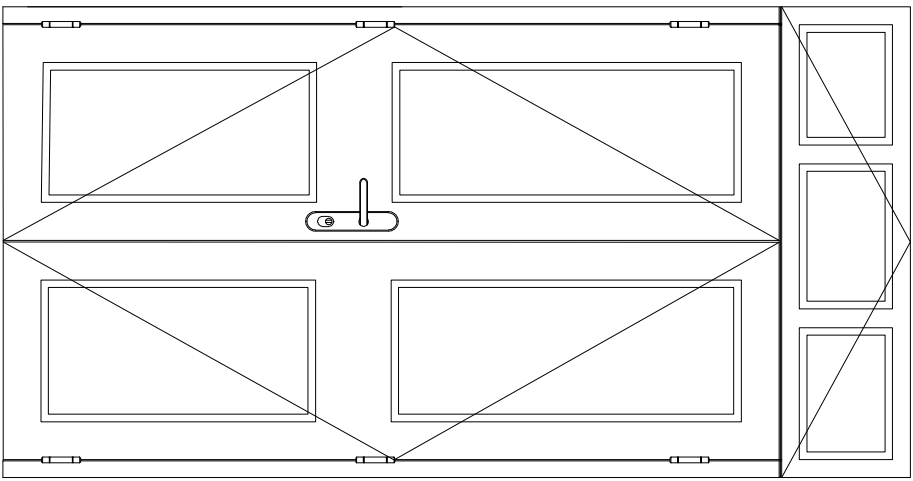

J Timber Doorset

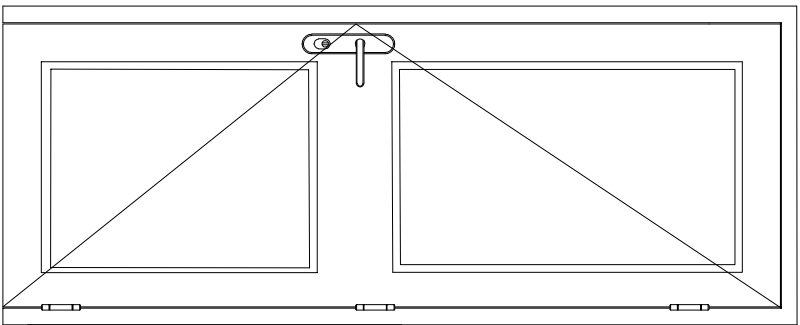

K Timber Doorset

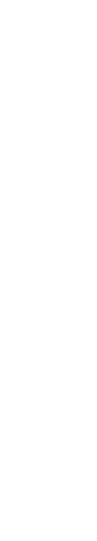
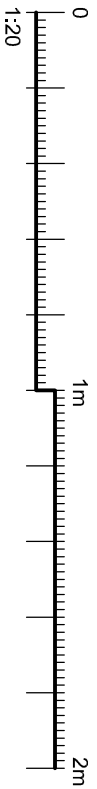

The contractor is responsible to ensure that no products are to be utilized that do not comply with relevant British and/or European Standards and/or Codes of Practice, Coshell Regulation, Construction regulations, or which are known or suspected at the time of product selection to be defective, unsafe, or which may compromise the health and safety or the durability of the work or not in accordance with good building practice.

The contractor is responsible for checking dimensions, tolerances, levels and references. The contractor is responsible for ensuring that all work is carried out in accordance with the drawings and specifications on site or shop drawings.

Where an item is covered by drawings to different scales, the larger scale drawing is to be worked to.

Do not scale drawings. Figure dimensions to be worked to in all cases.

This drawing and the copyright and patents therein are the property of Baily Garner LLP and may not be used or reproduced without consent or attribution.

A3

| | | | |
|-------------|--|-------------------|--|
| CLIENT: | Clarton Housing Group | PROJECT: | Window & Door Replacement Works |
| ADDRESS: | 36 Stratford Villas London NW1 9SG | TITLE: | Existing Rear Photos & Proposed Window Schedules |
| SCALE: | 1:20 @ A3 | PURPOSE OF ISSUE: | Planning |
| DRAWING NO: | 30668 | DATE: | 07/11/18 |
| REVISION: | | REVISION: | A |



146-148 ELTHAM HILL
LONDON, SE9 5DY
T. 020 8294 1000
F. 020 8294 1300
E. general@bailygarner.co.uk