

W00.01A

Fixed Wooden Window
1:10 @ A1, 1:20 @ A3

New Timber Window to match finish
and profile of existing window
Colour Black RAL9005 Interior White RAL 9010

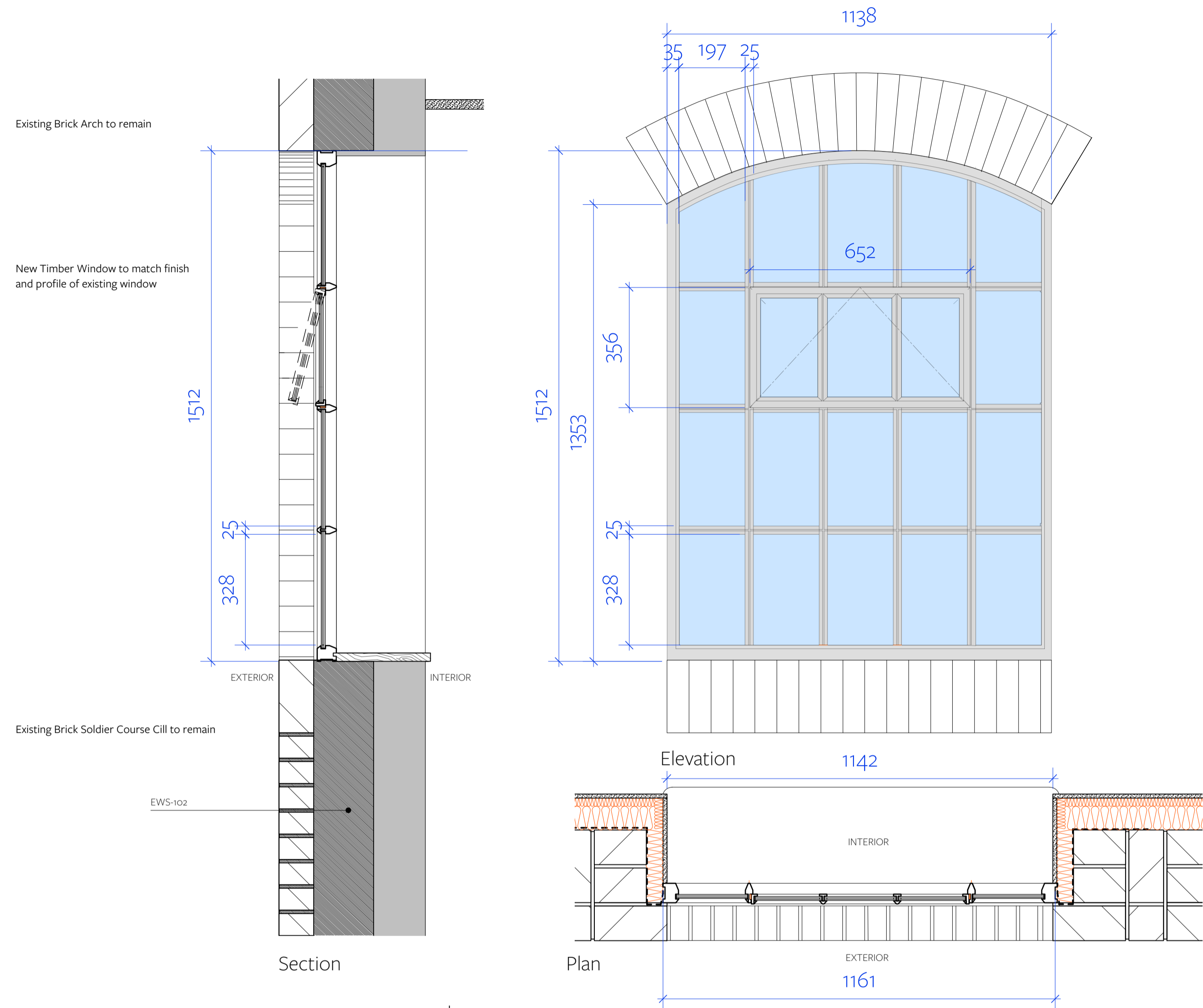

W00.01B

Fixed Wooden Window
1:10 @ A1, 1:20 @ A3

New Timber Window to match finish
and profile of existing window
Colour Black RAL9005 Interior White RAL 9010

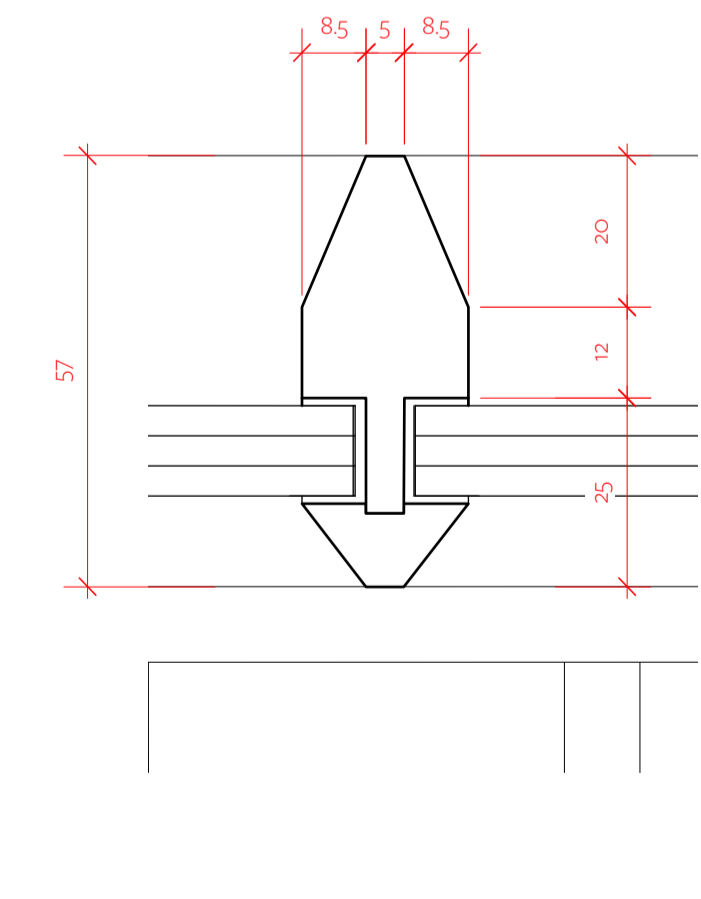
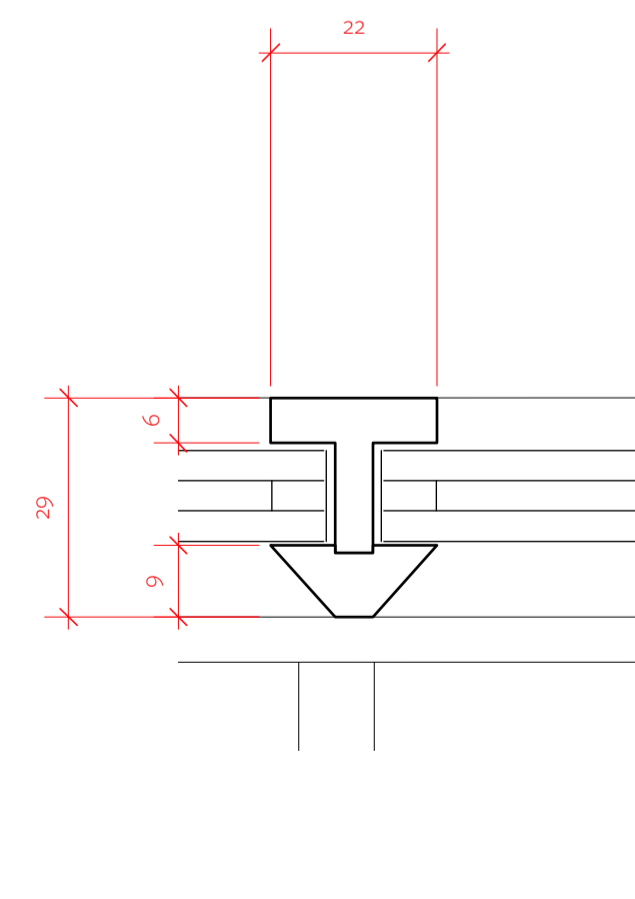
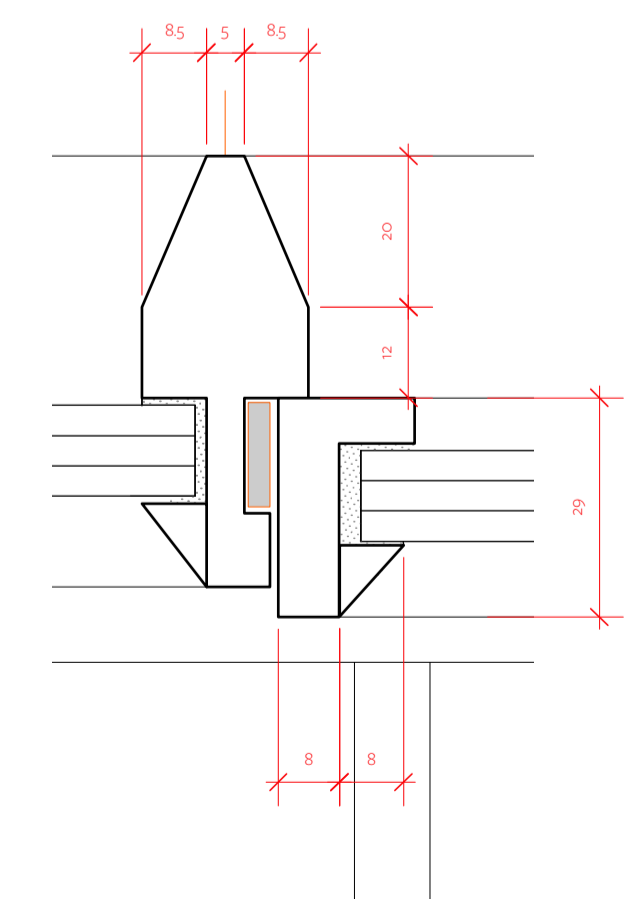
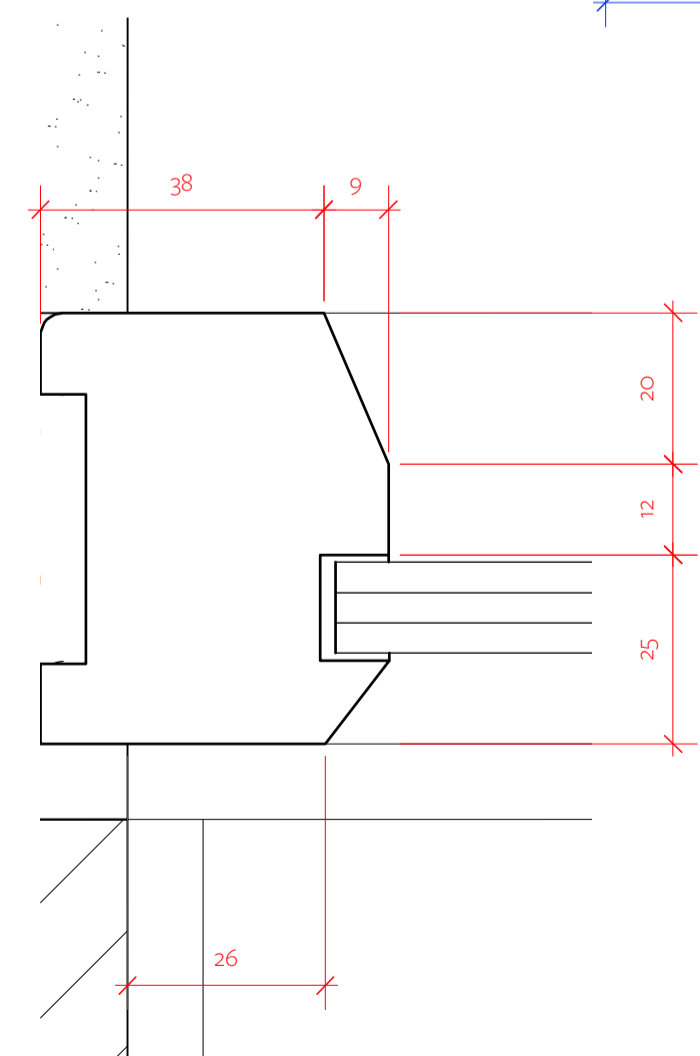
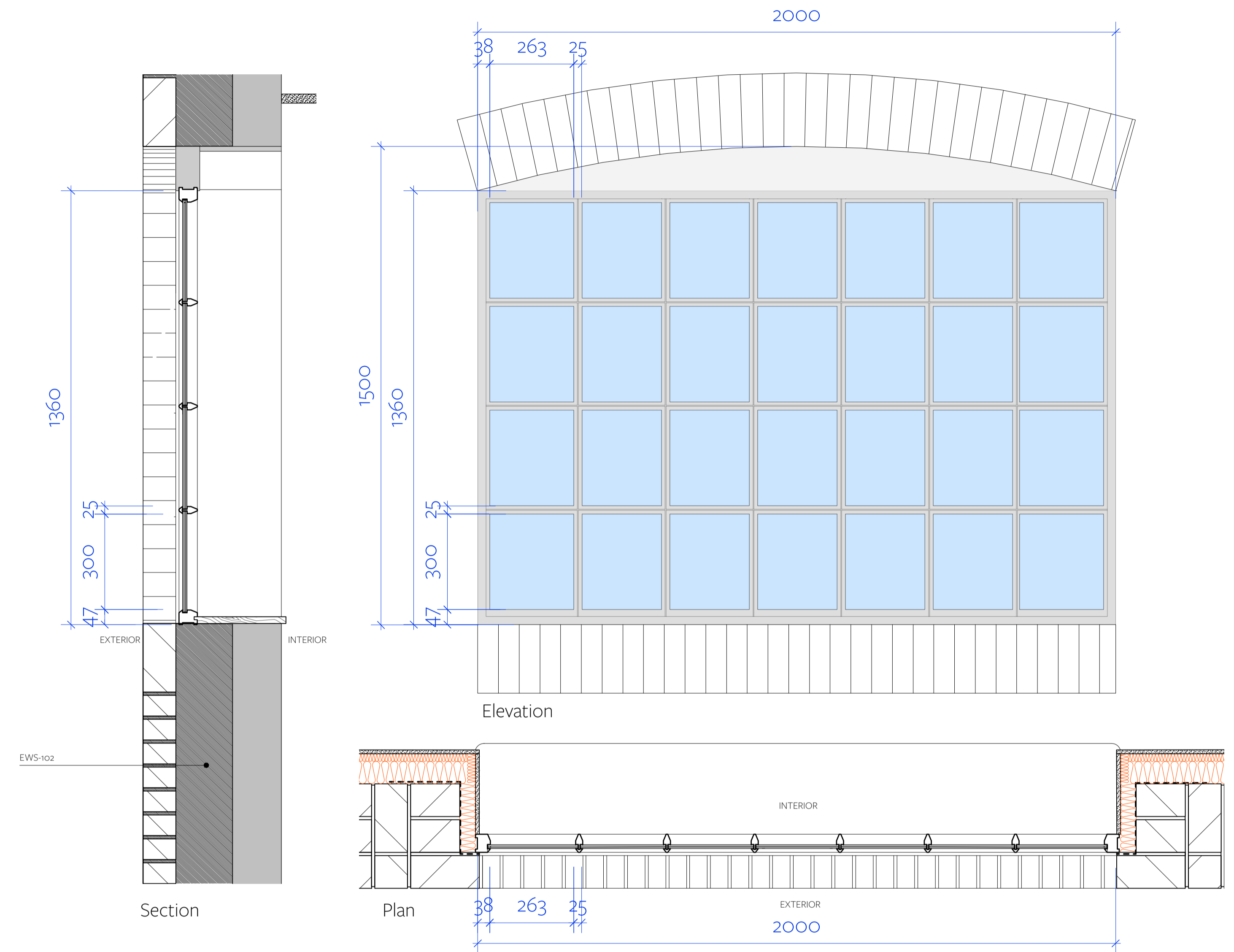

For Tender

Drawn by	Checked by	Date
AP	PAH	May 19

Information contained within this drawing is the sole copyright of TA Ltd and is not to be reproduced without express permission. No implied license exists. This drawing not to be used for land transfer or valuation purposes. Do not scale from this drawing. All dimensions & levels are to be checked on site by the contractor. Issues for purposes released only. Drawing errors and omissions to be reported to the architect.

Issue	Date	Description
01	19.06.2019	Issued for information
02	19.07.2019	Updated Following Krause Architects Comments
03	31.07.2019	Construction issue updated to KRAS comments

