

Steel and Stainless Steel Cycle Parking

OLLERTON

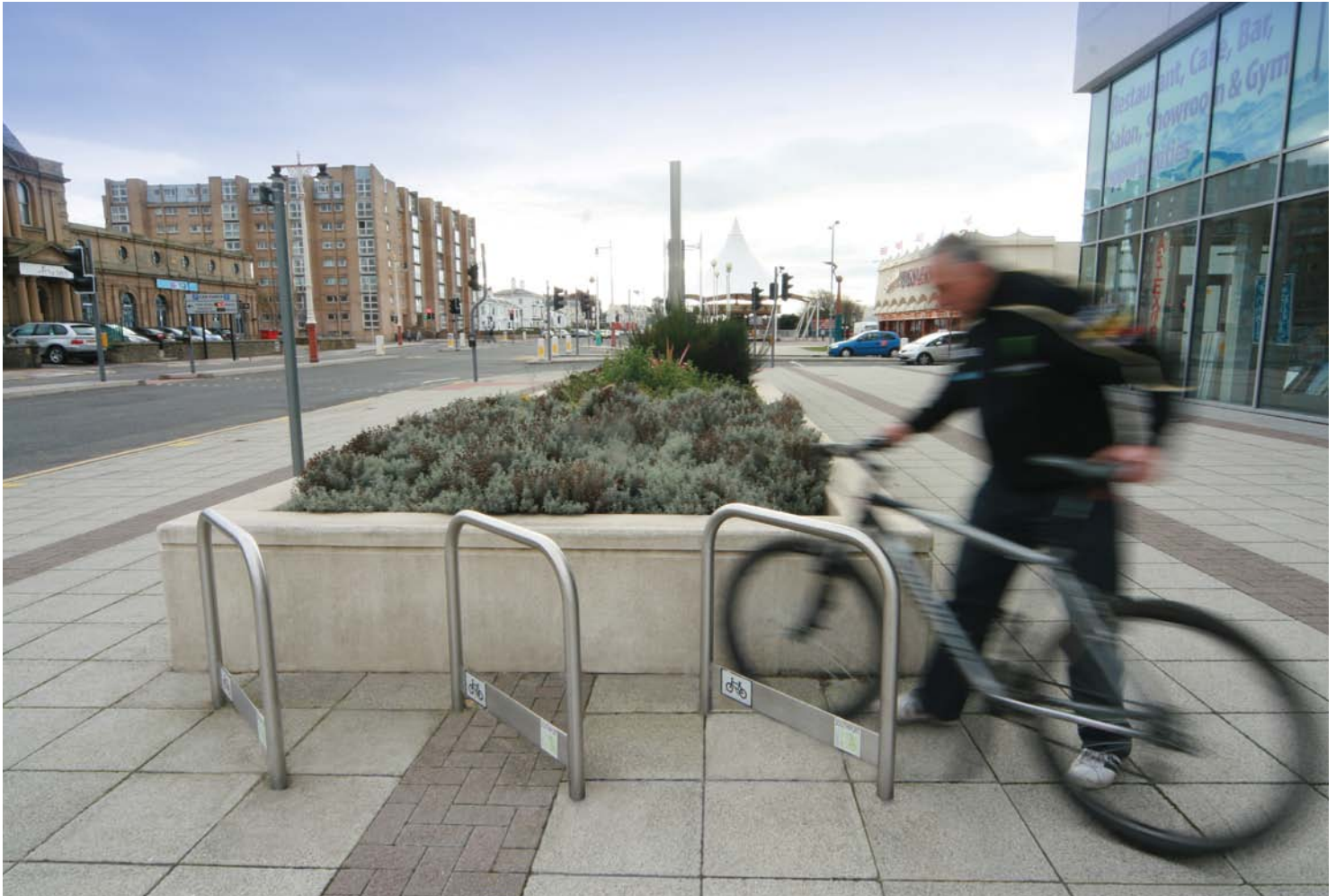

Sheffield Cycle Stands in Stainless Steel with bespoke Tapping Bar/Sign Strip, Southport

Over the past ten years, there has been a significant trend towards providing a more sustainable transport infrastructure. This has been driven by work being carried out by charity organisations such as Sustrans and independent bodies such as Cycling England. Both are committed to promoting sustainable travel, in particular cycling, to our places of work and schools.

One initiative promoting cycling across the UK is the National Cycle Network which operates over 230 million journeys each year, taking people to work and kids to school. In addition to this, there are other schemes such as 'Bike It' and 'Safe Routes to School'. More details on either of these can be found at www.sustrans.org.uk and www.saferoutestoschools.org.uk

Sustrans is one of the UK's leading sustainable transport charities, with the aim of reducing the environmental impact of transport and enabling people to choose active travel to benefit their health.

A key element in encouraging more people to adopt sustainable travel methods, such as cycling, is the provision of adequate facilities within our public spaces and schools. This incorporates ongoing development of a high quality cycling infrastructure, prioritising route design and selection, signage and cycle parking facilities.

The range of Ollerton cycle stands provides cyclists with an ideal solution to safely secure and store bicycles whilst not in use. A wide variety of stands is available in steel and stainless steel, with a selection of styles offered to complement any landscape.

Ollerton steel cycle stands are hot dip galvanised, giving excellent weathering qualities, and can be powder coated in a full range of standard RAL colours. Stainless steel cycle stands are manufactured from grade 316L stainless steel, meaning that they offer excellent corrosion resistance and require very little maintenance to retain their original contemporary appearance.

Steel and Stainless Steel Cycle Parking

Sheffield

OLLERTON



Sheffield Cycle Stands in Steel with bespoke Tapping Bar/Sign Strip, Southport

- Sheffield Cycle Stands are available galvanised, galvanised and powder coated and in grade 316L stainless steel.
- **Colour Options:** A full standard range of RAL colours is available, please see page 425.
- **Fixing Options:** Sheffield Cycle Stands can be supplied with either ground (root) fixing or base plate fixing.
- **Bespoke Options:** Sheffield Cycle Stands can be adapted to client requirements.

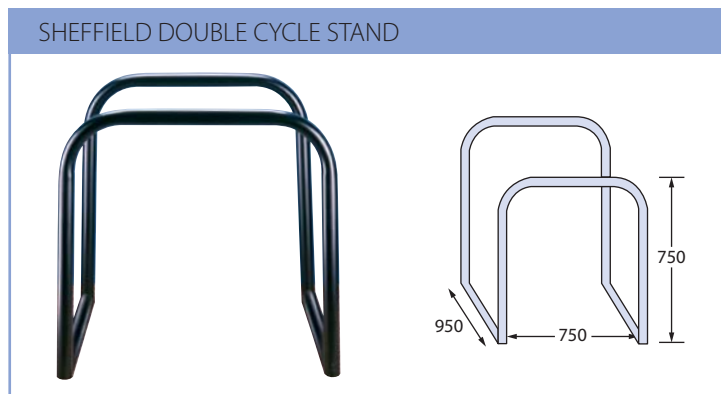
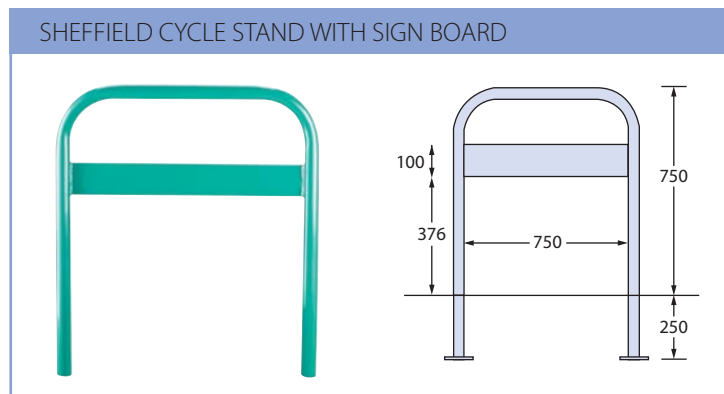
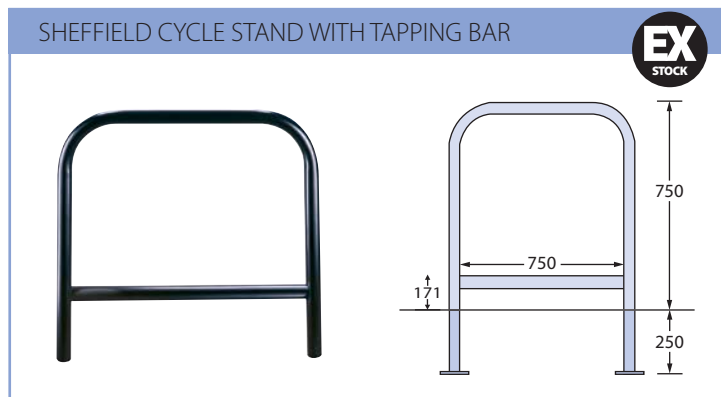
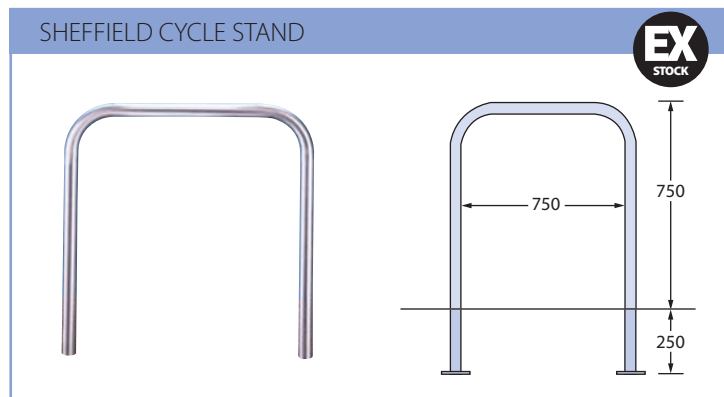

Steel and Stainless Steel Cycle Parking

OLLERTON



Pennant Stainless Steel Cycle Stands, Crown Point, Denton

- Cycle stands are available in a variety of different styles to meet both the functional requirements and aesthetics of any scheme.
- **Material:** Manufactured in mild steel which is galvanised to prevent corrosion and rusting. All designs are also available in grade 316L stainless steel, which contains a greater chromium and nickel content and includes molybdenum, this makes it more durable and less likely to rust or corrode or to have pit marks.
- **Finish:** Mild steel is available with a galvanised polyester powder coated finish. 10 RAL colours are offered as standard, with the rest of the range being available with an additional charge. Please see page 427 for further information.
- **Fixing Options:** All cycle parking is supplied as ground fixing (root fixing) as standard. Base plate fixing is available on request.

Upright Cycle Stand (RCS5)

- **Material:** Available in mild steel which is galvanised to prevent corrosion and rusting.
- **Finish:** Available with a galvanised only finish, or galvanised and polyester powder coated. A full range of RAL colours is available; please contact our Sales Office for more information or refer to page 425 for further information.
- **Fixing Options:** All cycle parking is supplied as root fixing as standard. Base plate fixing is available on request.

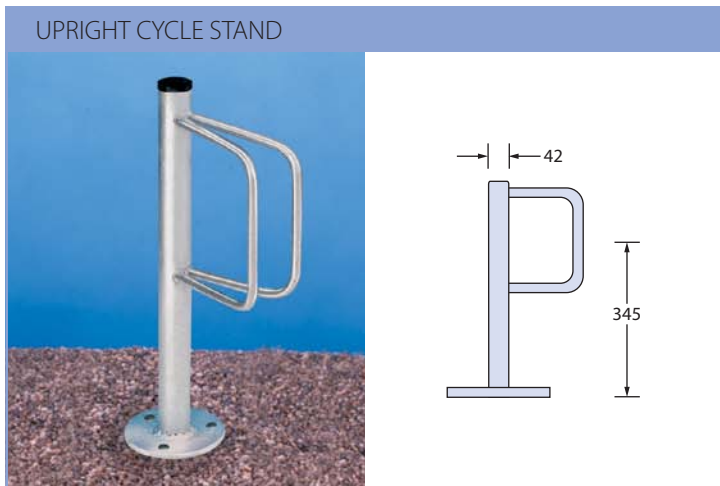
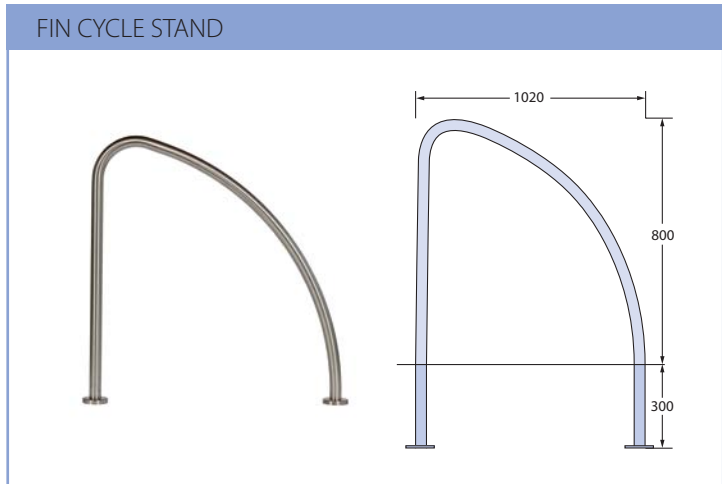
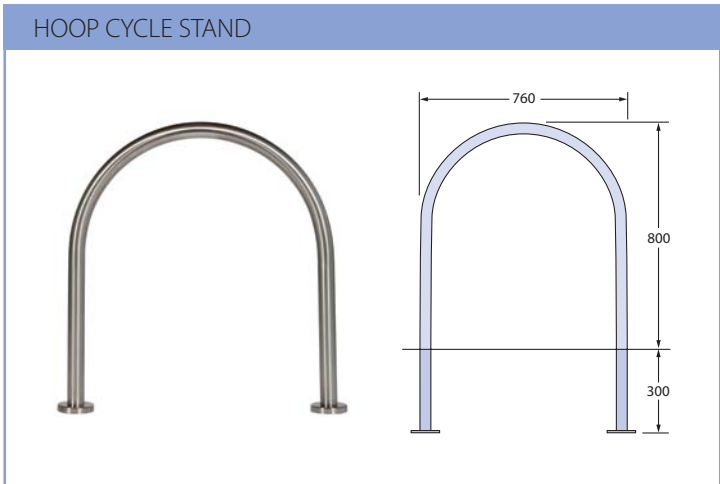
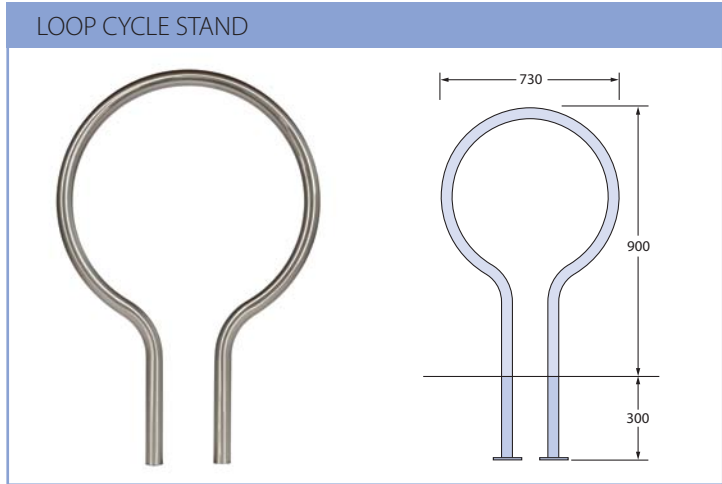
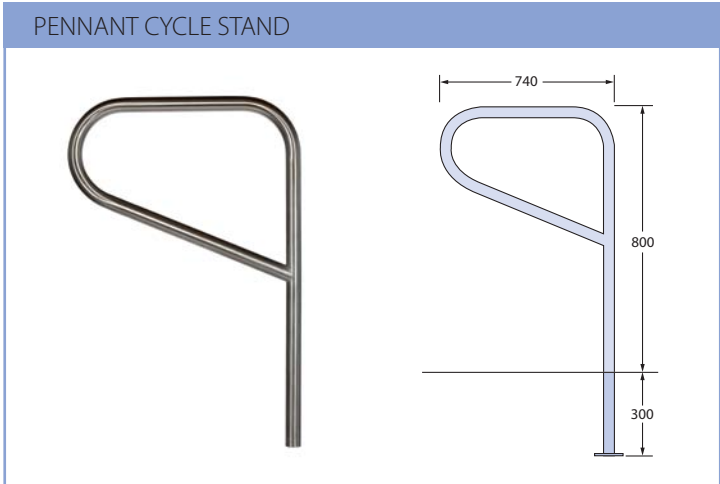

Product Description	Diameter (mm)	Span (mm)	HAG (mm)	Weight (kg)	Material	OPTIONS			Fixing Method		Guide Price*		
						Finish		Fixing Method		Guide Price*			
						Stainless Steel	Galvanised Only	Ground Fix	Base Plate	Galvanised	PC	Stainless Steel	
Sheffield Cycle Stand	48	750	750	11	■	Brushed Satin	■			£40	£50	£125	
Sheffield Cycle Stand with Tapping Bar	48	750	750	13	■	Brushed Satin	■			£55	£65	£172	
Sheffield Cycle Stand with Sign Board	48	750	750	13	■	Brushed Satin	■			£68	£78	£240	
Sheffield Double Cycle Stand	48	750	750	37	■	Brushed Satin	■			£105	£125	£425	
Pennant Cycle Stand	48	740	800	9				■	■	£105	£120	£225	
Fin Cycle Stand	48	1020	800	7				■	■	£105	£115	£198	
Loop Cycle Stand	48	730	900	7				■	■	£125	£135	£240	
Hoop Cycle Stand	48	760	800	7				■	■	£65	£72	£198	
Upright Cycle Stand	42	N/A	490	5			■			£56	n/a	n/a	

*Price based on root fixing. For other options contact Sales Office.