

**ENVIRONMENTAL ACOUSTIC
IMPACT ASSESSMENT**

**The Royal Free NHS Trust
Pond Street
Hampstead
London
NW3 2QG**

H-West Cooling Project

**Reference : CS8258-01
Revision : Original
Status : Draft Issue
Issue Date: 17th October 2019**

Prepared By:

Stuart Metcalfe

Stuart Metcalfe MIOA

CLIENT:

**ROYAL FREE LONDON NHS FOUNDATION TRUST
Pond Street
Hampstead
London
NW3 2QG**



Royal Free London
NHS Foundation Trust

Conabeare Acoustics Limited

11 Chiltern Enterprise Centre, Station Road, Theale, Berkshire. RG7 4AA
Telephone 0118 930 3650 Facsimile 0118 930 3912

sales@conabeare.co.uk

- 1.0 Introduction**
- 2.0 Acoustic Criteria**
- 3.0 Plant Location and Measurement Position**
- 4.0 Existing Sound Climate**
- 5.0 Noise Survey**
 - 5.1 Measurements**
 - 5.2 Weather during Survey Period**
 - 5.3 Instrumentation**
 - 5.4 Survey Results**
- 6.0 Assessment Methodology: BS4142:2014**
- 7.0 Noise Assessment**
- 8.0 Recommendations**
- 9.0 Conclusion**
- 10.0 Results Summary**
- 11.0 Results Graph**
- 12.0 Appendix**

Glossary of Terms
Calibration Certificates

1 Introduction

Conabeare Acoustics Limited have been commissioned by The Royal Free London NHS Foundation Trust to undertake an Acoustic Survey and BS4142:2014 assessment in relation to noise emissions of proposed plant at The Royal Free London Hospital, Pond Street, Hampstead, London NW3 2QG.

The Survey was undertaken by Stuart Metcalfe MIOA who has been practicing in Building Services Acoustics and Noise Control Engineering for in excess of 30 years, is a Member of the Institute of Acoustics (MIOA) and is a Director at Conabeare Acoustics Ltd.

2 Acoustic Criteria

BS4142:2014 Methods for rating and assessing industrial and commercial sound.

BS4142:2014 gives a method for rating sound from industrial and commercial sources affecting people inside or outside dwellings or premises used for residential purposes.

An initial estimate of the significance of the sound from the industrial/commercial nature can be assessed by subtracting the measured background noise level from the rating level (this is the specific sound level of the source with any corrections or penalties for distinctive acoustic characteristics).

Typically, the greater the difference, the greater the magnitude of the impact.

The site is located within the London Borough of Camden demise which has adopted the National Planning Policy Guidelines and as such References and evaluations are to be made to the National Planning Policy Framework 2012 (NPPF) and the Noise Policy Statement for England 2010 (NPSE).

There are several key phrases within the NPSE aims and these are discussed below. “Significant adverse” and “adverse”

NOEL – No Observed Effect Level - This is the level below which no effect can be detected. In simple terms, below this level, there is no detectable effect on health and quality of life due to the noise.

LOAEL – Lowest Observed Adverse Effect Level - This is the level above which adverse effects on health and quality of life can be detected. Extending these concepts for the purpose of this NPSE leads to the concept of a significant observed adverse effect level.

SOAEL – Significant Observed Adverse Effect Level - This is the level above which significant adverse effects on health and quality of life occur.

Conabeare Acoustics Limited

This Camden requirement for noise exposure are detailed in the Local Plan Appendix 3: Noise thresholds which is reproduced thus;

Industrial and Commercial Noise Sources

A relevant standard or guidance document should be referenced when determining values for LOAEL and SOAEL for non-anonymous noise. Where appropriate and within the scope of the document it is expected that British Standard 4142:2014 ‘Methods for rating and assessing industrial and commercial sound’ (BS 4142) will be used. For such cases a ‘Rating Level’ of 10 dB below background (15dB if tonal components are present) should be considered as the design criterion).

Table C: Noise levels applicable to proposed industrial and commercial developments (including plant and machinery)

<i>Existing Noise sensitive receptor</i>	<i>Assessment Location</i>	<i>Design Period</i>	<i>LOAEL (Green)</i>	<i>LOAEL to SOAEL (Amber)</i>	<i>SOAL (Red)</i>
<i>Dwellings**</i>	<i>Garden used for main amenity (free field) and Outside living or dining or bedroom window (façade)</i>	<i>Day</i>	<i>‘Rating level’ 10dB* below background</i>	<i>‘Rating level’ between 9dB below and 5dB above background</i>	<i>‘Rating level’ greater than 5dB above background</i>
<i>Dwellings**</i>	<i>Outside bedroom window (façade)</i>	<i>Night</i>	<i>‘Rating level’ 10dB* below background and no events exceeding 57dB_{LAmx}</i>	<i>‘Rating level’ between 9dB above background or noise events between 57dB and 88dB_{LAmx}</i>	<i>‘Rating level’ greater than 5dB above background and/or events exceeding 88dB_{LAmx}</i>

**10dB should be increased to 15dB if the noise contains audible tonal elements. (day and night). However, if it can be demonstrated that there is no significant difference in the character of the residual background noise and the specific noise from the proposed development then this reduction may not be required. In addition, a frequency analysis (to include, the use of Noise Rating (NR) curves or other criteria curves) for the assessment of tonal or low frequency noise may be required.*

***levels given are for dwellings, however, levels are use specific and different levels will apply dependent on the use of the premises.*

The periods in Table C correspond to 0700 hours to 2300 hours for the day and 2300 hours to 0700 hours for the night. The Council will take into account the likely times of occupation for types of development and will be amended according to the times of operation of the establishment under consideration.

There are certain smaller pieces of equipment on commercial premises, such as extract ventilation, air conditioning units and condensers, where achievement of the rating levels (ordinarily determined by a BS:4142 assessment) may not afford the necessary protection. In these cases, the Council will generally also require a NR curve specification of NR35 or below, dependant on the room (based upon measured or predicted Leq,5mins noise levels in octave bands) 1 metre from the façade of affected premises, where the noise sensitive premise is located in a quiet background area.

3 Plant Location and Measurement Position

The site is located on Pond Street in the Hampstead District in North West London.

The area consists of a mixture of residential and commercial premises with the sound sensitive façade in question being adjudged to be the residential premises in Pond Street.

The nearest sound sensitive façades are at a distance of approximately 60 metres from the proposed plant. The sound sensitive facade has partial direct line of site to the plant with some screening from the building edge.

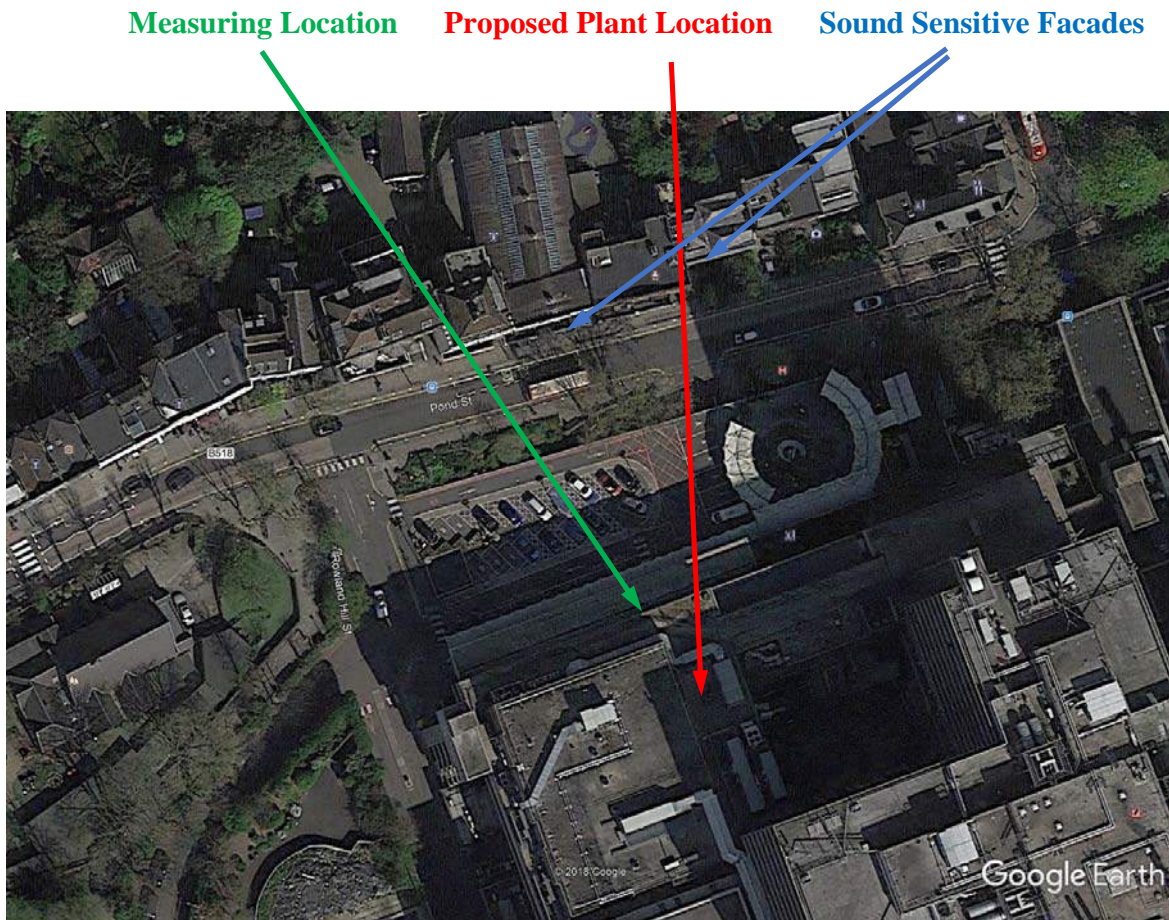

Conabeare Acoustics Limited

11 Chiltern Enterprise Centre, Station Road, Theale, Berkshire. RG7 4AA
Telephone 0118 930 3650 Facsimile 0118 930 3912
sales@conabeare.co.uk

Rev	Rev Date	Revision Description	Drawn/Checked	Purpose of Issue

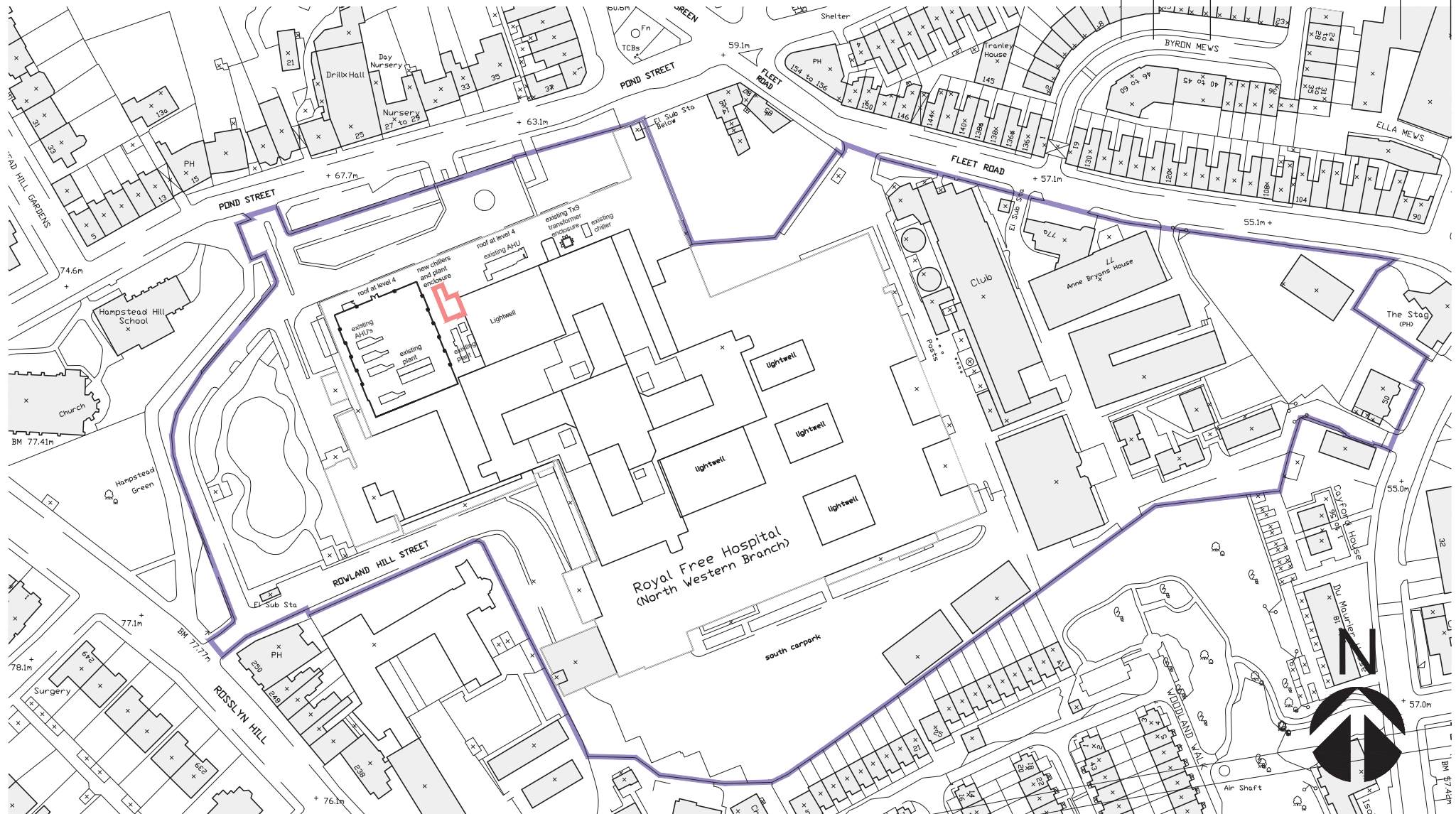

 Royal Free London Boundary Line

 Proposed Area of Works on Flat Roof over Level 3 (Level 4 Roof)



Work in Progress For 1:1250 scale

Site Location Plan	19020	(00)001	/
Royal Free London NHS Foundation Trust H-West Theatre Cooling	Oct 2019	1:1250@A3	
	DATE	SCALE	

THIS DRAWING IS PROTECTED BY COPYRIGHT - FIGURED DIMENSIONS ONLY TO BE TAKEN FROM THIS DRAWING. DIMENSIONS TO BE CHECKED ON SITE AND ANY DISCREPANCIES REPORTED TO THE ARCHITECT IMMEDIATELY.

PURPOSE OF ISSUE: (I)Info/Comment (S)Sign Off (P)Planning (B)Building Control (T)Tender (C)Construction (R)Record

Rev	Rev Date	Revision Description	Drawn/Checked	Purpose of Issue

Flat roof over Level 3 (Level 4 Roof)

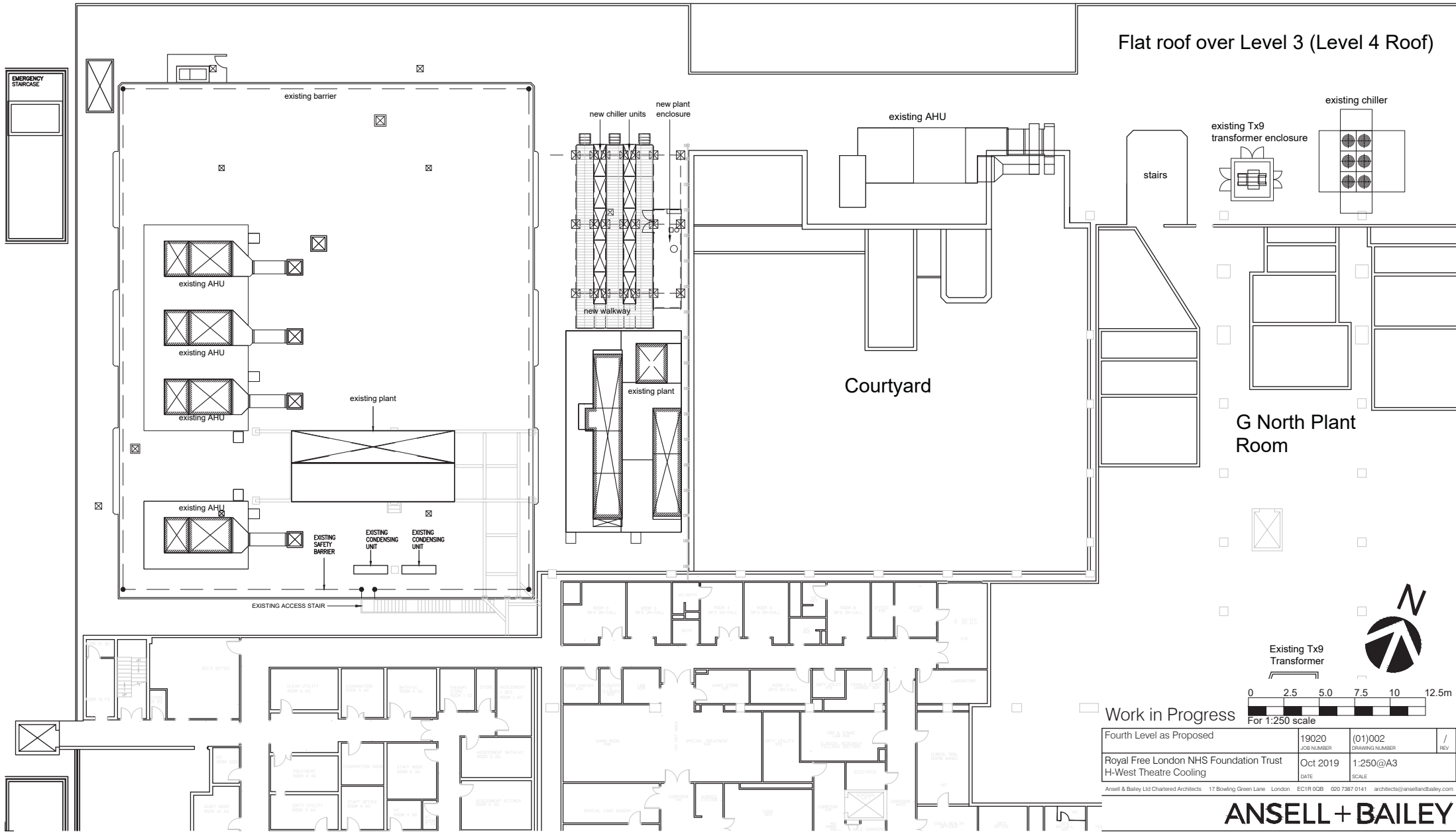

Work in Progress

Fourth Level as Proposed	19020	(01)002	/
Royal Free London NHS Foundation Trust H-West Theatre Cooling	Oct 2019	1:250@A3	REV
	DATE	SCALE	

Ansell & Bailey Ltd Chartered Architects 17 Bowling Green Lane London EC1R 0GB 020 7387 0141 architects@ansellandbailey.com

ANSELL + BAILEY

THIS DRAWING IS PROTECTED BY COPYRIGHT - FIGURED DIMENSIONS ONLY TO BE TAKEN FROM THIS DRAWING. DIMENSIONS TO BE CHECKED ON SITE AND ANY DISCREPANCIES REPORTED TO THE ARCHITECT IMMEDIATELY.

PURPOSE OF ISSUE: (I)Info/Comment (S)Sign Off (P)Planning (B)Building Control (T)Tender (C)Construction (R)Record

Rev	Rev Date	Revision Description	Drawn/Checked	Purpose of Issue

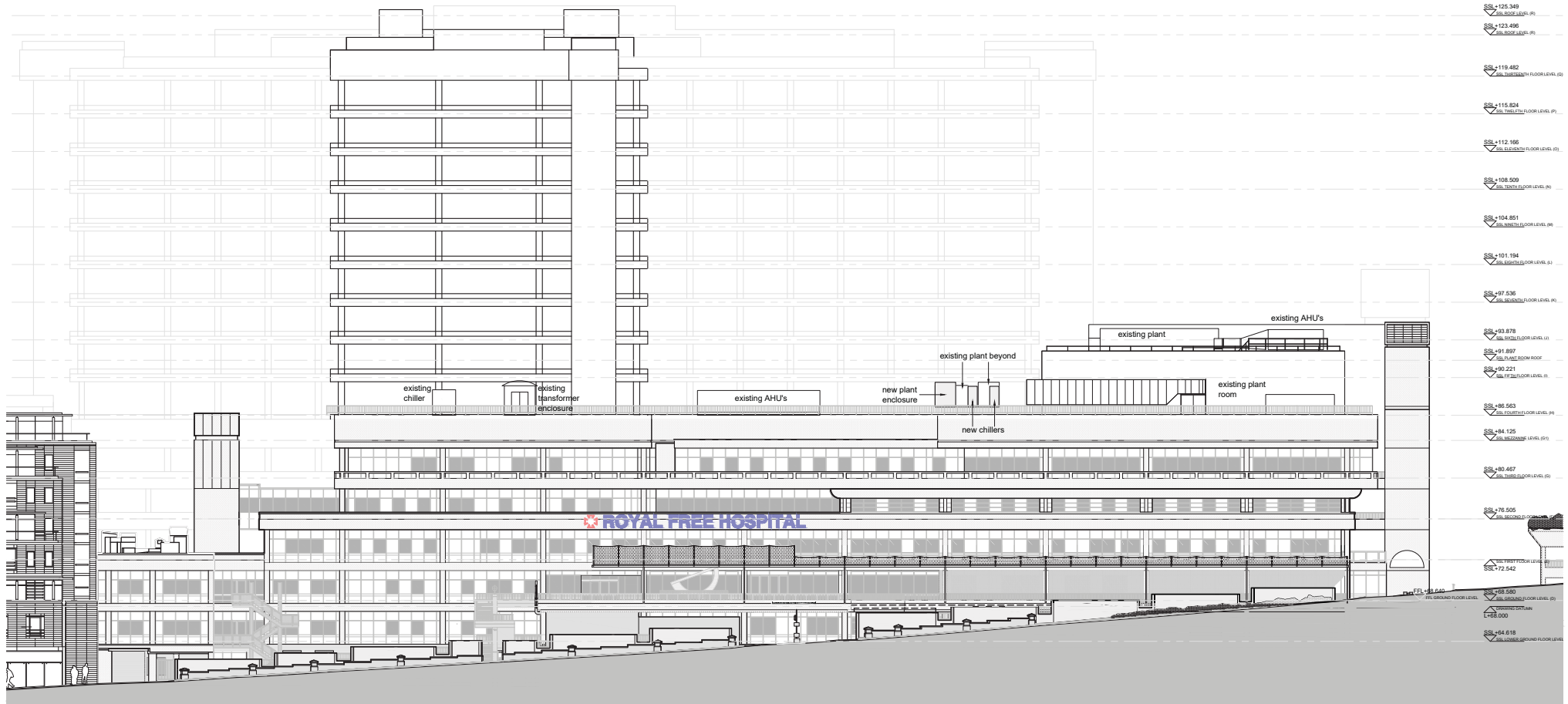

NORTH ELEVATION

Work in Progress

0 2 4 6 8 10m
FOR 1:200 SCALE

Proposed North Elevation	19020 JOB NUMBER	(02)002 DRAWING NUMBER	/
Royal Free London NHS Foundation Trust H-West Theatre Cooling	Oct 2019 DATE	1:200@A1, 1:400@A3 SCALE	/ REV

Ansell & Bailey Ltd Chartered Architects 17 Bowling Green Lane London EC1R 0QB 020 7387 0141 architects@ansellandbailey.com

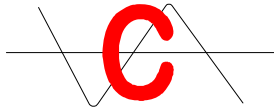

Photo 1 – Measuring Location
Showing nearest Sound Sensitive Facade



Photo 2 – Proposed Plant Location

4 Existing Noise Climate

The area is generally a mixture of commercial and residential premises with transportation noise from the area being adjudged to be the dominant background noise source during the survey period.

The survey location was chosen as it was close to the proposed plant location with direct views to the sound sensitive facades but away from existing plant.

5 Noise Survey

5.1 Measurements

The Survey commenced at approximately 09:00 hours on Thursday 10th October 2019 until approximately 08:55 hours on Friday 11th October 2019.

The Analyser was programmed to record 15 minute sampling periods over the survey duration.

The microphone was located on a handrail at approximately 1.5 metres above a reflecting plane.

The measurements and their interpretation are in accordance with BS 7445: Parts 1 and 2. All readings are Sound Pressure Levels (L_p) in dB (re 20µPa).

Conabeare Acoustics Limited

11 Chiltern Enterprise Centre, Station Road, Theale, Berkshire. RG7 4AA
Telephone 0118 930 3650 Facsimile 0118 930 3912
sales@conabeare.co.uk

5.2 Weather during Survey Period

The weather was warm and dry with some rain showers. The weather did not, in our opinion, adversely influence the readings obtained.

5.3 Instrumentation

The instrumentation used was a Type 1 Larson Davis LxT Sound Expert Sound Level Analyser confirming to IEC 651-1979 Type 1, EN60651 Type 1 and IEC 804-1985 Type 1, EN60804 Type 1.

- **Larson Davis LxT Sound Level Analyser, Serial Number 0005588.**
- **Larson Davis PRMLxT1L Preamplifier, Serial Number 055664.**

The Sound Analyser and Preamplifier are new items of equipment and were factory calibrated on 20th April 2018, Certificate Numbers 2018004098 and 2018004083 respectively.

The additional following equipment was also used

- **CEL type 284/2 Calibrator, Serial Number 4/05022369 calibrated on 21st February 2017, Certificate Number 15179.**
- **Extension Cable**

Field calibration checks were made using the Calibrator and no significant drift was noted against the Calibration level of $114.0\text{dB} \pm 0.2\text{dB}$ at $1000\text{Hz} \pm 0.2\%$.

5.4 Survey Results

The following is a summary of the Background (L_{A90}) levels recorded in Daytime, Evening and Night-time Periods

- $L_{A90,15\text{min}}$ 56.1dB(A) between 07:00 hours to 19:00 hours.
- $L_{A90,15\text{min}}$ 55.1dB(A) between 19:00 hours to 23:00 hours.
- $L_{A90,15\text{min}}$ 53.7dB(A) between 23:00 hours to 07:00 hours.

6 Assessment Methodology: BS4142:2014

A revision of British Standard BS 4142 was published at the end of October 2014 and replaces the previous 1997 edition. The main aim of the standard is to provide an assessment and rating method that is proportionate, sufficiently flexible and suitable for use by practitioners to inform professional judgement. The foreword to the standard clearly states that:

Conabeare Acoustics Limited

11 Chiltern Enterprise Centre, Station Road, Theale, Berkshire. RG7 4AA
Telephone 0118 930 3650 Facsimile 0118 930 3912
sales@conabeare.co.uk

“The execution of its provisions will be entrusted to appropriately qualified and experienced people, for whose use it has been produced.”

It does this by providing a method for the determination of:

- rating levels for sources of an industrial and/or commercial nature; and
- ambient, background and residual sound levels.

An assessment framework is provided to allow the practitioner to use the rating, ambient, background and residual sound levels determined using the standard for the purposes of:

- 1) investigating complaints;*
- 2) assessing sound from proposed, new, modified or additional source(s) of sound of an industrial and/or commercial nature; and*
- 3) assessing sound at proposed new dwellings or premises used for residential purposes.*

The scope of the standard has now been widened to rating and assessing:

- a) sound from industrial and manufacturing processes;*
- b) sound from fixed installations which comprise mechanical and electrical plant and equipment;*
- c) sound from the loading and unloading of goods and materials at industrial and/or commercial premises; and*
- d) sound from mobile plant and vehicles that is an intrinsic part of the overall sound emanating from premises or processes, such as that from forklift trucks, or that from train or ship movements on or around an industrial and/or commercial site.”*

It can also be seen from above that the standard explicitly states that it can be used to investigate complaints and has been significantly widened to cover not only new, modified or additional sources of sound, but also the assessment of sound affecting new dwellings or premises to be used for residential purposes.

Like the 1997 edition, the standard provides a method for correcting the specific sound levels so as to account for acoustic features that are present at the assessment location. The approach in the 1997 edition was purely subjective and allowed for a +5 dB correction irrespective of how prominent the feature was or whether there was one feature only or a combination of tones, impulses or other features irregular enough to attract attention. The 2014 edition provides for scaled corrections up to +6 dB for tones and up to +9 dB for impulses, depending upon the prominence of the tones or impulses, as well as +3 dB corrections for:

- other sound characteristics that are neither tonal nor impulsive; and/or
- intermittent features when the sound has identifiable on/off conditions.

Conabeare Acoustics Limited

11 Chiltern Enterprise Centre, Station Road, Theale, Berkshire. RG7 4AA
Telephone 0118 930 3650 Facsimile 0118 930 3912
sales@conabeare.co.uk

The corrections for tones and impulses can be assessed using subjective or reference methods. There is also an objective method for tones, which is based upon the prominence of sound pressure levels in the one-third-octave-band containing a tone in comparison to the sound pressure levels in the adjacent one-third-octave-bands.

The objective method however, does not allow for different corrections to be applied for tones differing in prominence as it only allows for a single correction of +6 dB for clearly prominent tones.

The 1997 edition assessed the likelihood of complaints using the difference between the rating level and the background sound level. A difference of around +10 dB or more indicated complaints are likely, a difference of around +5 dB was of marginal significance and a difference of more than 10 dB below the background was considered to provide a positive indication that complaints were unlikely.

The 2014 edition no longer assesses the likelihood of complaints. Instead, it can be used to assess adverse impacts.

This change was introduced because the likelihood of complaints is not a particularly appropriate benchmark, especially when it is used in a planning context, and it also aligns the standard more closely with the type of language and benchmarks that are suitable for the assessment of sound at the planning stage for new proposed development.

It continues to use the difference between the rating level and the background sound level, though it also introduces the requirement to consider the context and states that:

- a) Typically, the greater this difference, the greater the magnitude of the impact.*
- b) A difference of around +10 dB or more is likely to be an indication of a significant adverse impact, depending on the context.*
- c) A difference of around +5 dB is likely to be an indication of an adverse impact, depending on the context.*
- d) The lower the rating level is relative to the measured background sound level, the less likely it is that the specific sound source will have an adverse impact or a significant adverse impact. Where the rating level does not exceed the background sound level, this is an indication of the specific sound source having a low impact, depending on the context.”*

Conabeare Acoustics Limited

The context includes consideration of pertinent factors, such as:

- the absolute level of sound;
- the character and level of the residual sound compared to the character and level of the specific sound;
- the sensitivity of the receptor and whether dwellings or other premises used for residential purposes will already incorporate design measures that secure good internal and/or outdoor acoustic conditions.

7 Noise Assessment

The objective of any specification limiting new noises should therefore be to ensure that sound emission from the new building services plant should not materially add to the existing sound climate.

The proposed plant being assessed is as detailed below;

- 10 number – Mitsubishi EACV-P900YA-N Air Cooled Chiller

As these items of plant have the potential to run on a 24 hour basis we would recommend setting a target level at the nearest sound sensitive façade as below;

$$L_{Aeq,15min} 43dB(A) - 24 \text{ hours.}$$

Mitsubishi EACV-P900YA-N Air Cooled Chiller

Specific Noise Source

The Specific Noise Source is 77dBA Lw.

Acoustic Feature Correction

We have allowed for a +3dB Acoustic Correction Feature for the sound sensitive façade.

This item of plant is not considered to be particularly tonal or intermittent in nature, so no allowance has been made.

The units were measured in an anechoic chamber with the Lw levels being derived from the data obtained and as such we have allowed for a +3dB increase to allow for any reflected noise.

Additional Units

There are a total of 10 units so an addition of +10dB has allowed for multiple equal noise sources.

Conabeare Acoustics Limited

11 Chiltern Enterprise Centre, Station Road, Theale, Berkshire. RG7 4AA
Telephone 0118 930 3650 Facsimile 0118 930 3912

sales@conabeare.co.uk

Distance Attenuation

The nearest sound sensitive façade is at a distance of approximately 60 metres from the proposed plant. The distance loss will therefore be -47dB based upon parallelepiped noise propagation.

Barrier Attenuation

There are no specific barriers between the plant and the sound sensitive façade however the building edge will offer a degree of screening offering partial line of site screening and this has been calculated to be a reduction of -5dB.

BS4142 Assessment

BS4142 Assessment – 24 Hours	dBA
Specific Noise Level	77
Acoustic Feature Correction	+6
Additional Sources	+10
Distance Attenuation	-47
Barrier Attenuation	-5
Rating Level	41
Background (L _{A90}) Level	53
Rating Above Background Level	-12

This item of plant therefore is therefore 12dBA **below** the measured Background Level.

The assessment would indicate that the plant will have a GREEN rating of *NOEL – No Observed Effect Level* as it is more than 10dBA below the measured background level.

8 Recommendations

No mitigating measures would be required as these items of plant would be below the No Observed Effect Level at the nearest sound sensitive façade.

9 Conclusion

A background Noise Survey was carried out during a typical night time period at a location representative of the nearest sound sensitive receivers.

An assessment has then been carried out in respect of the individual item of plant.

The proposed plant is below the Local Authority requirement for noise levels and therefore should, in our opinion, be acceptable as regards the noise emissions.

Conabeare Acoustics Limited

CS8258 - The Royal Free Hospital, Pond Street, London NW3 2QG

- Period result profile -

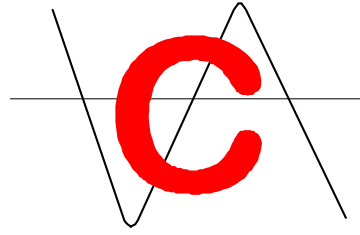

Overload occurred	No
Low battery occurred	No
Pause was used	No
Frequency weighting	A
Band	Broadband
Period time	15 min
Periods too short for LNs	No
First period listed	1 : 97
Measurement Description	
Start	10/10/2019 08:59
Stop	11/10/2019 08:50
Duration	23:51:19.6
Run Time	23:51:19.6
Pause	00:00.0
Pre Calibration	10/010/2019 08:49:18

Period number	Date	Time	LN90.0% F dB, (A)	LN10.0% F dB, (A)	Leq dB, (A)
1	10/10/2019	08:59:26	60.2	69.6	65.6
2	10/10/2019	09:00:00	57.8	64.3	63.6
3	10/10/2019	09:15:00	57.3	62.3	61.1
4	10/10/2019	09:30:00	57.7	62.4	60.4
5	10/10/2019	09:45:00	57.8	61.7	60.1
6	10/10/2019	10:00:00	58.0	62.6	60.9
7	10/10/2019	10:15:00	58.2	62.5	60.8
8	10/10/2019	10:30:00	58.0	62.4	62.7
9	10/10/2019	10:45:00	58.3	62.4	63.5
10	10/10/2019	11:00:00	58.5	63.8	61.9
11	10/10/2019	11:15:00	58.3	63.2	61.4
12	10/10/2019	11:30:00	57.9	62.6	64.7
13	10/10/2019	11:45:00	58.6	65.1	63.0
14	10/10/2019	12:00:00	58.3	63.9	62.7
15	10/10/2019	12:15:00	57.8	61.4	60.5
16	10/10/2019	12:30:00	58.0	61.7	60.7
17	10/10/2019	12:45:00	58.0	63.4	60.9
18	10/10/2019	13:00:00	58.8	64.2	62.1
19	10/10/2019	13:15:00	58.8	63.6	62.3
20	10/10/2019	13:30:00	57.8	61.7	60.2
21	10/10/2019	13:45:00	57.5	60.7	59.8
22	10/10/2019	14:00:00	57.9	62.4	64.6
23	10/10/2019	14:15:00	57.5	65.4	67.0
24	10/10/2019	14:30:00	57.3	61.5	60.0
25	10/10/2019	14:45:00	57.9	63.6	63.9
26	10/10/2019	15:00:00	57.0	61.1	59.2
27	10/10/2019	15:15:00	57.3	61.4	59.6
28	10/10/2019	15:30:00	57.6	63.5	61.6
29	10/10/2019	15:45:00	57.6	65.3	65.8
30	10/10/2019	16:00:00	57.1	62.1	61.1
31	10/10/2019	16:15:00	57.3	61.6	59.7
32	10/10/2019	16:30:00	57.2	61.1	59.6
33	10/10/2019	16:45:00	57.5	62.5	62.4
34	10/10/2019	17:00:00	57.2	61.5	59.9
35	10/10/2019	17:15:00	57.3	61.3	59.5
36	10/10/2019	17:30:00	57.4	61.3	59.4
37	10/10/2019	17:45:00	56.3	61.6	62.3
38	10/10/2019	18:00:00	57.0	62.0	61.9
39	10/10/2019	18:15:00	56.7	60.8	59.0
40	10/10/2019	18:30:00	56.6	61.9	60.3
41	10/10/2019	18:45:00	56.8	60.9	59.2

Period number	Date	Time	LN90.0% F dB, (A)	LN10.0% F dB, (A)	Leq dB, (A)
42	10/10/2019	19:00:00	56.1	60.2	58.2
43	10/10/2019	19:15:00	56.6	61.5	59.7
44	10/10/2019	19:30:00	56.2	61.3	59.7
45	10/10/2019	19:45:00	56.1	60.8	58.9
46	10/10/2019	20:00:00	56.0	60.7	58.8
47	10/10/2019	20:15:00	56.2	61.6	61.6
48	10/10/2019	20:30:00	55.6	60.7	58.6
49	10/10/2019	20:45:00	55.7	60.7	58.6
50	10/10/2019	21:00:00	55.3	61.7	59.6
51	10/10/2019	21:15:00	55.3	60.8	58.4
52	10/10/2019	21:30:00	55.5	60.5	58.5
53	10/10/2019	21:45:00	55.3	60.3	58.2
54	10/10/2019	22:00:00	55.2	60.7	58.8
55	10/10/2019	22:15:00	55.2	60.8	58.4
56	10/10/2019	22:30:00	55.1	60.5	58.1
57	10/10/2019	22:45:00	55.1	60.0	57.9
58	10/10/2019	23:00:00	54.9	60.3	57.8
59	10/10/2019	23:15:00	55.2	60.9	58.1
60	10/10/2019	23:30:00	54.9	60.1	57.7
61	10/10/2019	23:45:00	54.9	60.0	58.8
62	11/10/2019	00:00:00	54.4	59.0	56.9
63	11/10/2019	00:15:00	54.5	60.3	57.5
64	11/10/2019	00:30:00	54.2	59.7	56.8
65	11/10/2019	00:45:00	54.1	59.1	56.7
66	11/10/2019	01:00:00	53.9	58.6	56.3
67	11/10/2019	01:15:00	53.9	57.3	55.8
68	11/10/2019	01:30:00	54.2	57.7	55.9
69	11/10/2019	01:45:00	54.2	57.1	55.9
70	11/10/2019	02:00:00	53.9	56.9	55.6
71	11/10/2019	02:15:00	53.9	57.1	55.6
72	11/10/2019	02:30:00	53.8	56.3	55.3
73	11/10/2019	02:45:00	53.7	55.9	55.0
74	11/10/2019	03:00:00	53.8	56.4	55.1
75	11/10/2019	03:15:00	53.8	57.0	55.5
76	11/10/2019	03:30:00	53.8	57.9	56.0
77	11/10/2019	03:45:00	54.4	58.5	56.9
78	11/10/2019	04:00:00	54.3	57.7	56.4
79	11/10/2019	04:15:00	54.3	58.9	56.7
80	11/10/2019	04:30:00	54.4	58.3	56.6
81	11/10/2019	04:45:00	54.2	57.6	56.0
82	11/10/2019	05:00:00	54.2	58.5	56.5
83	11/10/2019	05:15:00	54.3	58.4	56.2
84	11/10/2019	05:30:00	54.4	59.9	57.2
85	11/10/2019	05:45:00	54.5	59.7	57.2
86	11/10/2019	06:00:00	54.6	60.5	57.8
87	11/10/2019	06:15:00	55.1	60.4	57.9
88	11/10/2019	06:30:00	55.4	60.2	58.0
89	11/10/2019	06:45:00	55.5	61.4	59.5
90	11/10/2019	07:00:00	56.0	61.9	59.0
91	11/10/2019	07:15:00	56.6	62.1	59.9
92	11/10/2019	07:30:00	56.5	62.4	60.0
93	11/10/2019	07:45:00	56.7	61.4	59.4
94	11/10/2019	08:00:00	57.1	62.1	64.8
95	11/10/2019	08:15:00	57.7	62.8	60.7
96	11/10/2019	08:30:00	57.9	63.3	60.9
97	11/10/2019	08:45:00	58.0	65.0	64.6

CS8258 - Royal Free Hospital, Pond Street, London NW3 2QG

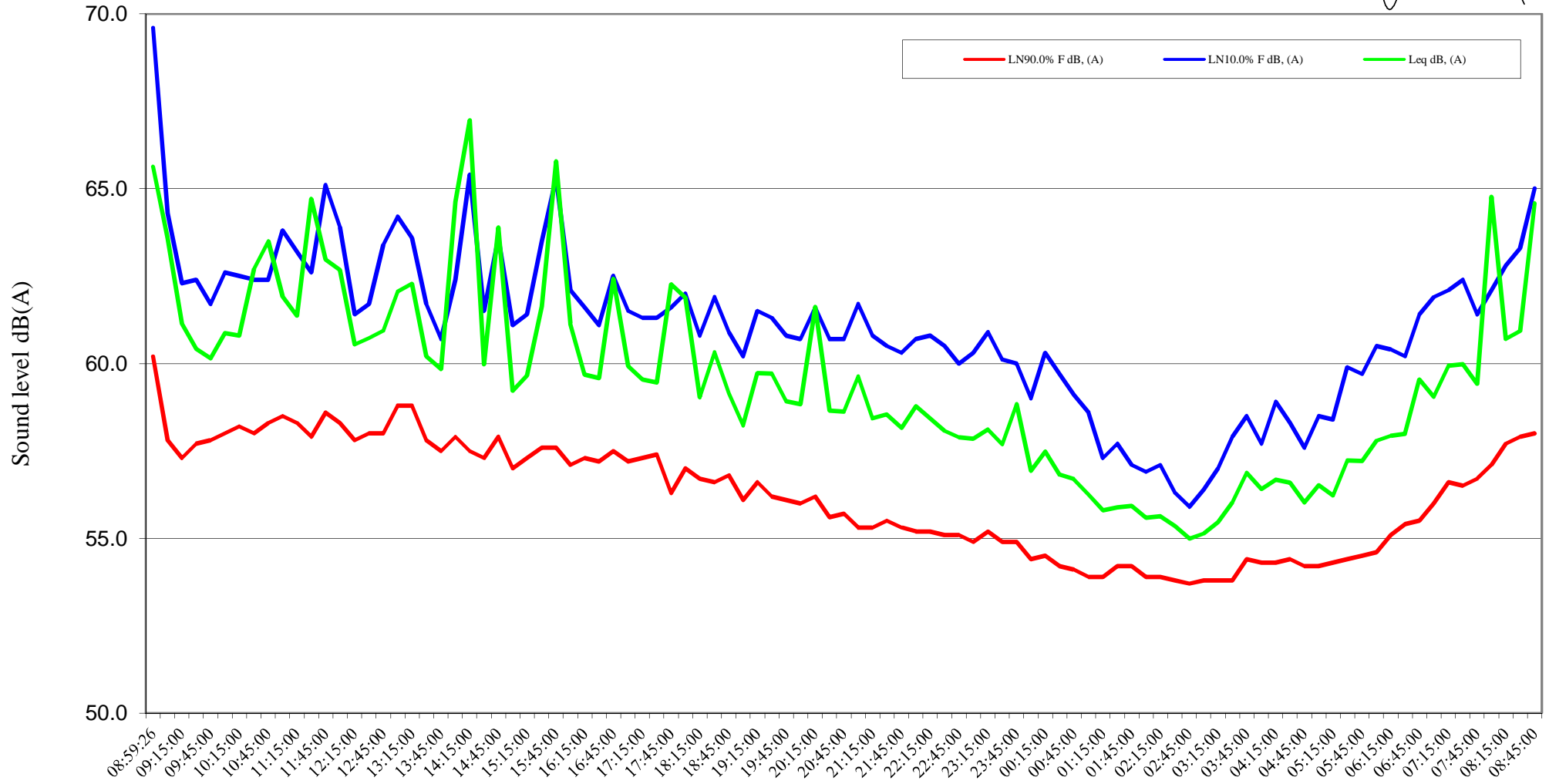
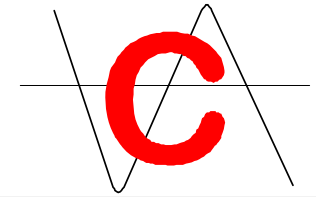

10th October 2019 to 11th October 2019 - Time

Glossary of Terms

- L_{A90}** The sound pressure level in dB(A) which is exceeded for 90% of the time and is taken to be the effective lowest background sound level for the period by such methods of sound rating as that recommended in BS4142:2014. It will also be used as a basis for selecting limiting sound levels from new plant by Local Planning Authorities when setting Planning Consent Conditions.
- L_{Aeq}** The “equivalent continuous sound level” for the measuring period, defined as the level in dBA which, if held constant over the measuring period, would produce the same amount of sound energy as does the actual varying ambient sound level. It is a measure of the amount of sound energy affecting the site from sources other than new plant or operations.
- L_{A10}** The sound level exceeded for 10% of the time over the sample period. Originally used as a measure of subjective reaction to traffic noise in particular, it can also be taken as an indication of the practical maximum sound level that the building envelope will have to protect against.
- dBA** Describes measured on a sound level meter incorporating a frequency weighting (A weighting) which differentiates between sounds of different frequency (pitch) in a similar way to the human ear. Measurements in dBA broadly agree with people’s assessment of loudness. A change of 3dBA is the minimum perceptible under normal conditions, and a change of 10dBA corresponds roughly to halving or doubling the loudness of a sound.

Conabeare Acoustics Limited



The **e-series chiller** allows for up to six individual units to be connected together to provide a system capacity from 90kW to 1,080kW. Using this modular approach reduces space requirements and simplifies lifting and installation. The e-series chiller is available as a cooling only or heat pump version, suitable for both comfort and process cooling applications.

Key Features

- Two high efficiency advanced DC inverter-driven scroll compressors are incorporated within each 90kW module and four within the 150/180kW modules. This allows the unit to operate between 8% ~ 100% of capacity, producing exceptional part load efficiencies
- Two-stage cooling circuit - both compressors (or pair of compressors) serve separate plate heat exchangers located in the centre of the unit
- Reduced plant space - each size module can be positioned in a row of up to six connected units using the same internal header
- Internal header pipe - the in-built internal header pipes simplify design, installation and maintenance and also reduces space requirements, making the e-series range modular and suitable for almost any situation
- High performance compact air heat exchanger - the use of U-shaped or Y-shaped heat exchangers allows for a greater surface area, maximising efficiency whilst also keeping the units much narrower than conventional chillers. Blue Fin anti-corrosion coating on the heat exchanger is also provided as standard on the 90kW module



MODEL		EACV-P900YA-N Cooling Only	EACV-P1500YBL-N Cooling Only	EACV-P1800YBL-N Cooling Only
POWER SOURCE		3-phase 4-wire 380-400-415v, 50/60Hz	3-phase 4-wire 380-400-415v, 50/60Hz	3-phase 4-wire 380-400-415v, 50/60Hz
COOLING CAPACITY ¹ WATER		kW	90.0	150.0
		kcal/h	77,400	129,000
		BTU/h	307,080	511,800
	Power Input	kW	27.27	45.1
	EER (Pump input is not included)		3.30	3.33
	IPLV ³		6.34	6.55
	Water Flow Rate	m ³ /h	15.5	25.8
COOLING CAPACITY (EN14511) ² WATER		kW	90	148.6
		kcal/h	77,400	127,779
		BTU/h	307,080	506,955
	Power Input	kW	29.2	46.52
	EER		3.08	3.19
	Eurovent Efficiency Class		B	A
	ESEER ⁴		4.71	4.74
	SEER (η _{sc}) (BS EN14825)		4.88 (192%)	4.62 (181%)
	Water Flow Rate	m ³ /h	15.5	25.8
	Minimum Water Circuit Volume	L	420	800
COOLING CAPACITY BRINE (ethylene glycol 35WT%) ^{5,6}		kW	56.73	N/A
		kcal/h	48,788	N/A
		BTU/h	193,563	N/A
	Power Input	kW	25.98	N/A
	Current Input 380 - 400 - 415V	A	43.9 - 41.7 - 40.2	N/A
	EER (Pump input is not included)		2.18	N/A
	EER (Includes pump input based on EN14511)		2.10	N/A
	SEPR (η _{sc}) (BS EN14825)		6.11 (241%)	N/A
	Brine (ethylene glycol 35WT%) Flow Rate	m ³ /h	11.5	N/A
	Cooling Current 380 - 400 - 415V ¹	A	46.0 - 43.7 - 42.2	77 - 73 - 70
CURRENT INPUT	Maximum Current Input	A	61	111
	Water	kPa	135	114
WATER PRESSURE DROP ¹	Brine (ethylene glycol 35WT%) ⁵	kPa	106	N/A
	Cooling Water	°C	Outlet water 5 ~ 25	Outlet water 5 ~ 30
TEMP RANGE	Cooling Brine (ethylene glycol 35WT%) ⁵	°C	Outlet brine -10 ~ 25	N/A
	Heating	°C	N/A	N/A
	Outdoor	°C	-15 ~ 43 *6	-15 ~ 43
	Cooling Water	°C	Outlet water 5 ~ 25	Outlet water 5 ~ 30
CIRCULATING WATER VOLUME	m ³ /h	15.5	25.8	31
SOUND PRESSURE LEVEL (measured in anechoic room) at 1m ¹¹	dB(A)	65	66	68
SOUND POWER LEVEL (measured in anechoic room) ¹¹	dB(A)	77	84	86
DIAMETER OF WATER PIPE (Standard piping)	Inlet	mm	100A housing type joint	150A housing joint type
	Outlet	mm	100A housing type joint	150A housing joint type
EXTERNAL FINISH		Polyester powder coated steel plate	Polyester powder coated steel plate	Polyester powder coated steel plate
EXTERNAL DIMENSION	Width x Depth x Height	mm	2250 x 900 x 2450	3400 x 1080 x 2350
WEIGHT	Inside Header Piping "-N" Model	kg	1022	1256
DESIGN PRESSURE	R410A	MPa	4.15	4.15
	Water	MPa	1	1
HEAT EXCHANGER	Water Side		Stainless steel plate and copper brazing	Stainless steel plate and copper brazing
	Air Side		Plate fin and copper tube	Plate fin and copper tube
COMPRESSOR	Type		Inverter scroll hermetic compressor	Inverter scroll hermetic compressor
	Maker		Mitsubishi Electric Corporation	Mitsubishi Electric Corporation
	Starting Method		Inverter	Inverter
	Quantity		2	4
	Motor Output	kW	11.7 x 2	11.7 x 4
	Case Heater	kW	0.045 x 2	N/A
	Lubricant		MEL32	MEL32
	Starting Current	A	8.5	19.1
	Max Running Current	A	61	111
	FAN	Air Flow Rate	m ³ /min	77 x 6
L/s			1,283 x 6	4,417 x 4
cfm			2,719 x 6	9,357 x 4
Type, Quantity			Propeller fan x 6	Propeller fan x 4
Starting Method			Inverter	Inverter
PROTECTION	High Pressure Protection		High pres. sensor & High pres. switch at 4.15MPa (601psi)	High pres. sensor & High pres. switch at 4.15MPa (601psi)
	Inverter Circuit		Over-heat protection, Over-current protection	Over-heat protection, Over-current protection
	Compressor		Over-heat protection	Over-heat protection
REFRIGERANT	Charge (kg)	R410A (GWP 2088)	19 x 2	15 x 4
	CO ₂ Equivalent (t)		79.3	125.3
	Control		LEV	LEV

¹ Under normal cooling conditions at outdoor temp 35°CDB/24°CWB outlet water temp 7°C inlet water temp 12°C. Outlet brine temp -5°C inlet brine temp 0°C. Pump input not included.

² Under normal cooling conditions at outdoor temp 35°CDB/24°CWB outlet water temp 7°C inlet water temp 12°C. Pump input is included based on EN14511.

³ IPLV IS is calculated in accordance with AHRI 550 - 590.

⁴ ESEER is calculated in accordance with EUROVENT conditions.

⁵ Under normal cooling conditions at outdoor temp 35°CDB/24°CWB outlet brine temp -5°C inlet water temp 0°C.

⁶ Only EACV-P900YA-N capable of water flow temps to -10°C.

* Please always make water circulate, or take the circulation water out completely when not in use for long periods.

* The water circuit must be closed circuit.

* Due to continuous improvement, the above specifications may be subject to change without notice.

MODEL		EAHV-P900YA-N Heating/Cooling	EAHV-P1500YBL-N Heating/Cooling	EAHV-P1800YBL-N Heating/Cooling	
POWER SOURCE		3-phase 4-wire 380-400-415v, 50/60Hz	3-phase 4-wire 380-400-415v, 50/60Hz	3-phase 4-wire 380-400-415v, 50/60Hz	
COOLING CAPACITY ¹ WATER		kW	90.0	150.0	
		kcal/h	77,400	129,000	
		BTU/h	307,080	511,800	
	Power Input	kW	30.6	45.1	
	EER (Pump input is not included)		3.30	3.33	
	IPLV ⁵		6.34	6.55	
	Water Flow Rate	m ³ /h	15.5	25.8	
COOLING CAPACITY (EN14511) ² WATER		kW	90	148.6	
		kcal/h	77,400	127,779	
		BTU/h	307,080	506,955	
	Power Input	kW	29.2	46.52	
	EER		2.94	3.19	
	Eurovent Efficiency Class		B	A	
	ESEER ⁶		4.71	4.74	
	SEER (η _{sc}) (BS EN14825)		4.88 (192%)	4.62 (181%)	
	Water Flow Rate	m ³ /h	15.5	25.8	
	Minimum Water Circuit Volume	L	780	1450	
	HEATING CAPACITY ³		kW	90.0	150
		kcal/h	77,400	129,000	
		BTU/h	307,080	511,800	
Power Input ³		kW	25.71	44.59	
COP			3.50	3.36	
Water Flow Rate		m ³ /h	15.5	25.8	
		kW	90.0	151.42	
HEATING CAPACITY (EN14511) ⁴		kcal/h	77,400	130,221	
		BTU/h	307,080	516,645	
	Power Input ³	kW	27.6	46.01	
	COP		3.25	3.29	
	Eurovent Efficiency Class		A+	A	
	SCOP Low/Medium		3.66 (143%) / 2.89 (113%)	3.24 (127%) / 2.85 (112%)	
	Water Flow Rate	m ³ /h	15.5	25.8	
	Cooling Current 380 - 400 - 415V ¹	A	46.0 - 43.7 - 42.3	77 - 73 - 70	
	Heating Current 380 - 400 - 415V ³	A	43.4 - 41.2 - 39.7	76 - 72 - 69	
	Maximum Current Input	A	61	111	
WATER PRESSURE DROP ¹	Water	kPa	135	114	
				164	
TEMP RANGE	Cooling Water	°C	Outlet water 5 ~ 25	Outlet water 5 ~ 30	
	Heating	°C	Outlet water 30 ~ 55	Outlet water 30 ~ 55	
	Outdoor	°C	-15 ~ 43	-15 ~ 43	
CIRCULATING WATER VOLUME	m ³ /h	15.5	25.8	31	
SOUND PRESSURE LEVEL (measured in anechoic room) at 1m ¹	dB(A)	65	66	68	
SOUND POWER LEVEL (measured in anechoic room) ¹	dB(A)	77	84	86	
DIAMETER OF WATER PIPE (Standard piping)	Inlet	mm	100A housing type joint	150A housing joint type	
	Outlet	mm	100A housing type joint	150A housing joint type	
EXTERNAL FINISH		Polyester powder coated steel plate	Polyester powder coated steel plate	Polyester powder coated steel plate	
EXTERNAL DIMENSION	Width x Depth x Height	mm	2250 x 900 x 2450	3400 x 1080 x 2350	
WEIGHT	Inside Header Piping "N" Model	kg	1022	1326	
DESIGN PRESSURE	R410A	MPa	4.15	4.15	
	Water	MPa	1	1	
HEAT EXCHANGER	Water Side		Stainless steel plate and copper brazing	Stainless steel plate and copper brazing	
	Air Side		Plate fin and copper tube	Plate fin and copper tube	
COMPRESSOR	Type		Inverter scroll hermetic compressor	Inverter scroll hermetic compressor	
	Maker		Mitsubishi Electric Corporation	Mitsubishi Electric Corporation	
	Starting Method		Inverter	Inverter	
	Quantity		2	4	
	Motor Output	kW	11.7 x 2	11.7 x 4	
	Case Heater	kW	0.045 x 2	N/A	
	Lubricant		MEL32	MEL32	
	Starting Current	A	8.5	19.1	
	Max Running Current	A	61	111	
	FAN	Air Flow Rate	m ³ /min	77 x 6	265 x 4
			L/s	1,283 x 6	4,417 x 4
cfm			2,719 x 6	9,357 x 4	
Type, Quantity			Propeller fan x 6	Propeller fan x 4	
Starting Method			Inverter	Inverter	
Motor Output	kW	0.19 x 6	0.94 x 4		
PROTECTION	High Pressure Protection		High pres. sensor & High pres. switch at 4.15MPa (601psi)	High pres. sensor & High pres. switch at 4.15MPa (601psi)	
	Inverter Circuit		Over-heat protection, Over-current protection	Over-heat protection, Over-current protection	
	Compressor		Over-heat protection	Over-heat protection	
REFRIGERANT	Charge (kg)	R410A (GWP 2088)	19 x 2	15 x 4	
	CO ₂ Equivalent (t)		79.3	125.3	
	Control		LEV	LEV	

¹ Under normal cooling conditions at outdoor temp 35°CDB/24°CWB outlet water temp 7°C inlet water temp 12°C. Pump input not included.

² Under normal cooling conditions at outdoor temp 35°CDB/24°CWB outlet water temp 7°C inlet water temp 12°C. Pump input is included based on EN14511.

³ Under normal heating conditions at outdoor temp 7°CDB/6°CWB outlet water temp 45°C inlet 40°C. Pump input not included.

⁴ Under normal heating conditions at outdoor temp 7°CDB/6°CWB outlet water temp 45°C inlet 40°C. Pump input power is included, based on EN14511.

⁵ IPLV IS is calculated in accordance with AHRI 550 - 590.

⁶ ESEER is calculated in accordance with EUROVENT conditions.

* Please always make water circulate, or take the circulation water out completely when not in use for long periods.

* The water circuit must be closed circuit.

* Due to continuous improvement, the above specifications may be subject to change without notice.

SYSTEM CONFIGURATIONS

MAXIMUM CAPACITY	90kW	150kW	180kW	270kW	300kW	360kW	450kW
COOLING ONLY	EACV-P900YA-N	EACV-P1500YBL-N	EACV-P900YA-N x2 EACV-P1800YBL-N	EACV-P900YA-N x3	EACV-P1500YBL-N x2	EACV-P900YA-N x4 EACV-P1800YBL-N x2	EACV-P900YA-N x5 EACV-P1500YBL-N x3
HEATING / COOLING	EAHV-P900YA-N	EAHV-P1500YBL-N	EAHV-P900YA-N x2 EAHV-P1800YBL-N	EAHV-P900YA-N x3	EAHV-P1500YBL-N x2	EAHV-P900YA-N x4 EAHV-P1800YBL-N x2	EAHV-P900YA-N x5 EAHV-P1500YBL-N x3

MAXIMUM CAPACITY	540kW	600kW	720kW	750kW	900kW	1,080kW
COOLING ONLY	EACV-P900YA-N x6 EACV-P1800YBL-N x3	EACV-P1500YBL-N x4	EACV-P1800YBL-N x4	EACV-P1500YBL-N x5	EACV-P1500YBL-N x6 EACV-P1800YBL-N x5	EACV-P1800YBL-N x6
HEATING / COOLING	EAHV-P900YA-N x6 EAHV-P1800YBL-N x3	EAHV-P1500YBL-N x4	EAHV-P1800YBL-N x4	EAHV-P1500YBL-N x5	EAHV-P1500YBL-N x6 EAHV-P1800YBL-N x5	EAHV-P1800YBL-N x6

EA(C)(H)V-P900YA-N DIMENSIONS

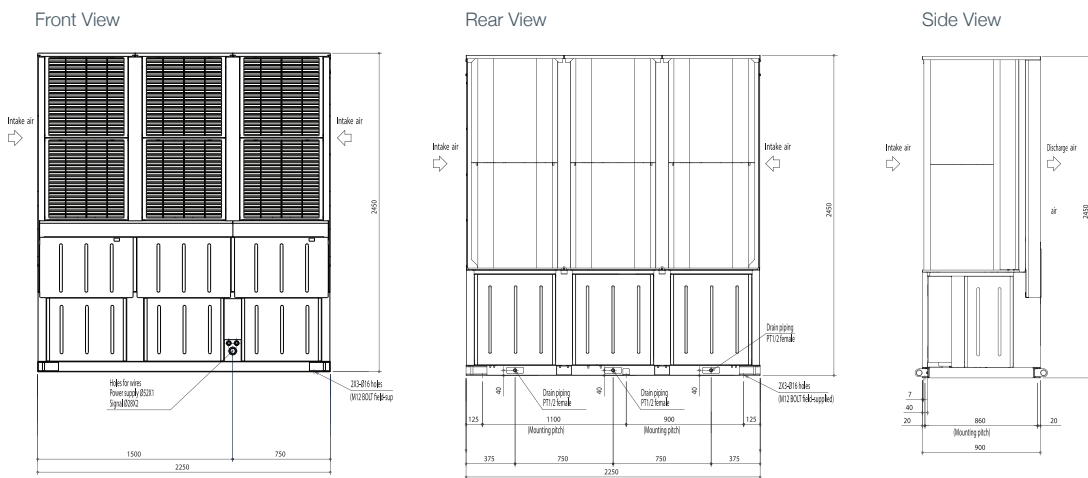

EA(C)(H)V-P1500/1800YBL-N DIMENSIONS

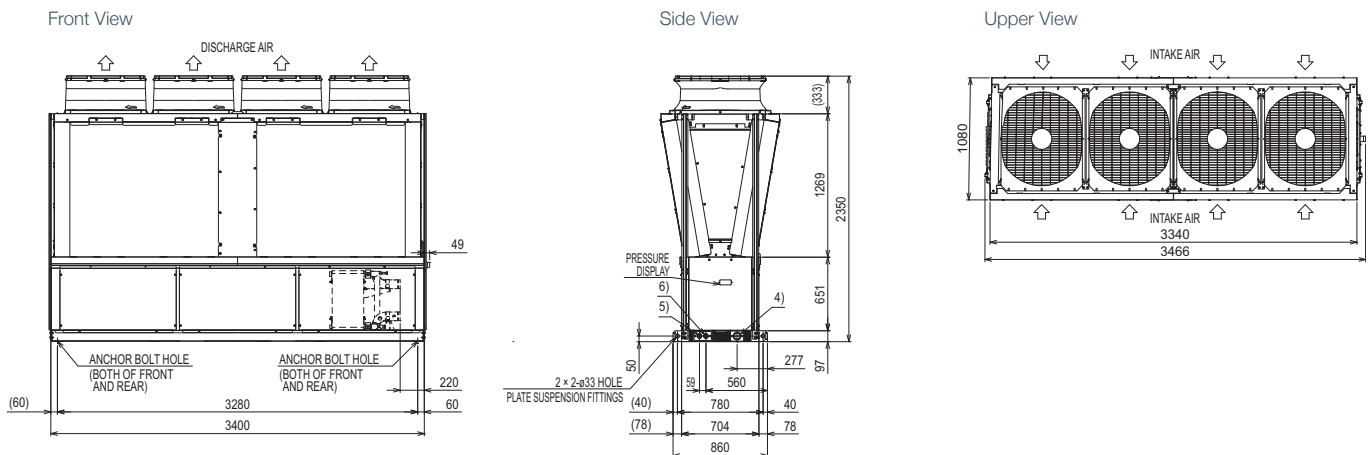

Telephone: 01707 282880
email: chillers@meuk.mee.com web: les.mitsubishielectric.co.uk microsite: mechillers.co.uk

UNITED KINGDOM Mitsubishi Electric Europe Living Environment Systems Division
Travellers Lane, Hatfield, Hertfordshire, AL10 8XB, England General Enquiries Telephone: 01707 282880 Fax: 01707 278881

IRELAND Mitsubishi Electric Europe Westgate Business Park, Ballymount, Dublin 24, Ireland
Telephone: Dublin (01) 419 8800 Fax: Dublin (01) 419 8890 International code: (003531)

Country of origin: United Kingdom – Japan – Thailand – Malaysia. ©Mitsubishi Electric Europe 2018. Mitsubishi and Mitsubishi Electric are trademarks of Mitsubishi Electric Europe B.V. The company reserves the right to make any variation in technical specification to the equipment described, or to withdraw or replace products without prior notification or public announcement. Mitsubishi Electric is constantly developing and improving its products. All descriptions, illustrations, drawings and specifications in this publication present only general particulars and shall not form part of any contract. All goods are supplied subject to the Company's General Conditions of Sale, a copy of which is available on request. Third-party product and brand names may be trademarks or registered trademarks of their respective owners.

Note: The fuse rating is for guidance only. Please refer to the relevant databook for detailed specification. It is the responsibility of a qualified electrician/electrical engineer to select the correct cable size and fuse rating based on current regulation and site specific conditions. Mitsubishi Electric's air conditioning equipment and heat pump systems contain a fluorinated greenhouse gas, R410A (GWP:2088), R32 (GWP:675), R407C (GWP:1774) or R134a (GWP:1430). *These GWP values are based on Regulation (EU) No 517/2014 from IPCC 4th edition. In case of Regulation (EU) No.626/2011 from IPCC 3rd edition, these are as follows: R410A (GWP:1975), R32 (GWP: 550), R407C (GWP:1650) or R134a (GWP:1300).



www.greengateway.mitsubishielectric.co.uk
Mitsubishi Electric UK's commitment to the environment

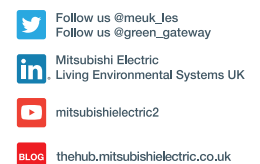

Calibration Certificate

Certificate Number 2018004098

Customer:

PC Environmental Ltd.
Unit 11 Mill Court
The Sawmills, Durley
Southampton, S032 2EJ, United Kingdom

Model Number LxT SE
Serial Number 0005588
Test Results **Pass**
Initial Condition As Manufactured
Description Sound Expert LxT
Class 1 Sound Level Meter
Firmware Revision: 2.302

Procedure Number D0001.8384
Technician Ron Harris
Calibration Date 20 Apr 2018
Calibration Due
Temperature 23.64 °C ± 0.25 °C
Humidity 50.4 %RH ± 2.0 %RH
Static Pressure 85.99 kPa ± 0.13 kPa

Evaluation Method **Tested with:** **Data reported in dB re 20 µPa.**

Larson Davis PRMLxT1L. S/N 055664
PCB 377B02. S/N 304334
Larson Davis CAL200. S/N 9079
Larson Davis CAL291. S/N 0108

Compliance Standards Compliant to Manufacturer Specifications and the following standards when combined with Calibration Certificate from procedure D0001.8378:

IEC 60651:2001 Type 1	ANSI S1.4-2014 Class 1
IEC 60804:2000 Type 1	ANSI S1.4 (R2006) Type 1
IEC 61252:2002	ANSI S1.11 (R2009) Class 1
IEC 61260:2001 Class 1	ANSI S1.25 (R2007)
IEC 61672:2013 Class 1	ANSI S1.43 (R2007) Type 1

Issuing lab certifies that the instrument described above meets or exceeds all specifications as stated in the referenced procedure (unless otherwise noted). It has been calibrated using measurement standards traceable to the International System of Units (SI) through the National Institute of Standards and Technology (NIST), or other national measurement institutes, and meets the requirements of ISO/IEC 17025:2005.

Test points marked with a ‡ in the uncertainties column do not fall within this laboratory's scope of accreditation.

The quality system is registered to ISO 9001:2008.

This calibration is a direct comparison of the unit under test to the listed reference standards and did not involve any sampling plans to complete. No allowance has been made for the instability of the test device due to use, time, etc. Such allowances would be made by the customer as needed.

The uncertainties were computed in accordance with the ISO Guide to the Expression of Uncertainty in Measurement (GUM). A coverage factor of approximately 2 sigma (k=2) has been applied to the standard uncertainty to express the expanded uncertainty at approximately 95% confidence level.

This report may not be reproduced, except in full, unless permission for the publication of an approved abstract is obtained in writing from the organization issuing this report.

Correction data from Larson Davis LxT Manual for SoundTrack LxT & SoundExpert Lxt, I770.01 Rev J Supporting Firmware Version 2.301, 2015-04-30

Larson Davis, a division of PCB Piezotronics, Inc
1681 West 820 North
Provo, UT 84601, United States
716-684-0001



For 1/4" microphones, the Larson Davis ADP024 1/4" to 1/2" adaptor is used with the calibrators and the Larson Davis ADP043 1/4" to 1/2" adaptor is used with the preamplifier.

Calibration Check Frequency: 1000 Hz; Reference Sound Pressure Level: 114 dB re 20 µPa

Periodic tests were performed in accordance with procedures from IEC 61672-3:2013 / ANSI/ASA S1.4-2014/Part3.

No Pattern approval for IEC 61672-1:2013 / ANSI/ASA S1.4-2014/Part 1 available.

The sound level meter submitted for testing successfully completed the periodic tests of IEC 61672-3:2013 / ANSI/ASA S1.4-2014/Part 3, for the environmental conditions under which the tests were performed. However, no general statement or conclusion can be made about conformance of the sound level meter to the full specifications of IEC 61672-1:2013 / ANSI/ASA S1.4-2014/Part 1 because (a) evidence was not publicly available, from an independent testing organization responsible for pattern approvals, to demonstrate that the model of sound level meter fully conformed to the class 1 specifications in IEC 61672-1:2013 / ANSI/ASA S1.4-2014/Part 1 or correction data for acoustical test of frequency weighting were not provided in the Instruction Manual and (b) because the periodic tests of IEC 61672-3:2013 / ANSI/ASA S1.4-2014/Part 3 cover only a limited subset of the specifications in IEC 61672-1:2013 / ANSI/ASA S1.4-2014/Part 1.

Standards Used

Description	Cal Date	Cal Due	Cal Standard
Larson Davis CAL291 Residual Intensity Calibrator	2017-09-19	2018-09-19	001250
SRS DS360 Ultra Low Distortion Generator	2017-06-23	2018-06-23	006311
Hart Scientific 2626-S Humidity/Temperature Sensor	2017-06-11	2018-06-11	006943
Larson Davis CAL200 Acoustic Calibrator	2017-07-25	2018-07-25	007027
Larson Davis Model 831	2018-02-28	2019-02-28	007182
PCB 377A13 1/2 inch Prepolarized Pressure Microphone	2018-03-07	2019-03-07	007185

Acoustic Calibration

Measured according to IEC 61672-3:2013 10 and ANSI S1.4-2014 Part 3: 10

Measurement	Test Result [dB]	Lower Limit [dB]	Upper Limit [dB]	Expanded Uncertainty [dB]	Result
1000 Hz	114.00	113.80	114.20	0.14	Pass

Acoustic Signal Tests, C-weighting

Measured according to IEC 61672-3:2013 12 and ANSI S1.4-2014 Part 3: 12 using a comparison coupler with Unit Under Test (UUT) and reference SLM using slow time-weighted sound level for compliance to IEC 61672-1:2013 5.5; ANSI S1.4-2014 Part 1: 5.5

Frequency [Hz]	Test Result [dB]	Expected [dB]	Lower Limit [dB]	Upper Limit [dB]	Expanded Uncertainty [dB]	Result
125	-0.21	-0.20	-1.20	0.80	0.23	Pass
1000	0.19	0.00	-0.70	0.70	0.23	Pass
8000	-2.60	-3.00	-5.50	-1.50	0.32	Pass

-- End of measurement results--



Self-generated Noise

Measured according to IEC 61672-3:2013 11.1 and ANSI S1.4-2014 Part 3: 11.1

Measurement	Test Result [dB]
A-weighted	44.37

-- End of measurement results--

-- End of Report--

Signatory: Ron Harris



Calibration Certificate

Certificate Number 2018004083

Customer:

PC Environmental Ltd.
Unit 11 Mill Court
The Sawmills, Durley
Southampton, S032 2EJ, United Kingdom

Model Number	PRMLxT1L	Procedure Number	D0001.8383
Serial Number	055664	Technician	Ron Harris
Test Results	Pass	Calibration Date	20 Apr 2018
Initial Condition	As Manufactured	Calibration Due	
Description	Larson Davis 1/2" Preamplifier for LxT Class 1 -1 dB	Temperature	23.64 °C ± 0.01 °C
		Humidity	50.9 %RH ± 0.5 %RH
		Static Pressure	85.87 kPa ± 0.03 kPa

Evaluation Method Tested electrically using a 12.0 pF capacitor to simulate microphone capacitance. Data reported in dB re 20 µPa assuming a microphone sensitivity of 50.0 mV/Pa.

Compliance Standards Compliant to Manufacturer Specifications

Issuing lab certifies that the instrument described above meets or exceeds all specifications as stated in the referenced procedure (unless otherwise noted). It has been calibrated using measurement standards traceable to the SI through the National Institute of Standards and Technology (NIST), or other national measurement institutes, and meets the requirements of ISO/IEC 17025:2005. Test points marked with a ‡ in the uncertainties column do not fall within this laboratory's scope of accreditation.

The quality system is registered to ISO 9001:2008.

This calibration is a direct comparison of the unit under test to the listed reference standards and did not involve any sampling plans to complete. No allowance has been made for the instability of the test device due to use, time, etc. Such allowances would be made by the customer as needed.

The uncertainties were computed in accordance with the ISO Guide to the Expression of Uncertainty in Measurement (GUM). A coverage factor of approximately 2 sigma (k=2) has been applied to the standard uncertainty to express the expanded uncertainty at approximately 95% confidence level.

This report may not be reproduced, except in full, unless permission for the publication of an approved abstract is obtained in writing from the organization issuing this report.

Standards Used

Description	Cal Date	Cal Due	Cal Standard
Larson Davis Model 2900 Real Time Analyzer	03/07/2018	03/07/2019	003003
Hart Scientific 2626-S Humidity/Temperature Sensor	06/11/2017	06/11/2018	006943
Agilent 34401A DMM	06/28/2017	06/28/2018	007165
SRS DS360 Ultra Low Distortion Generator	10/05/2017	10/05/2018	007167

Frequency Response

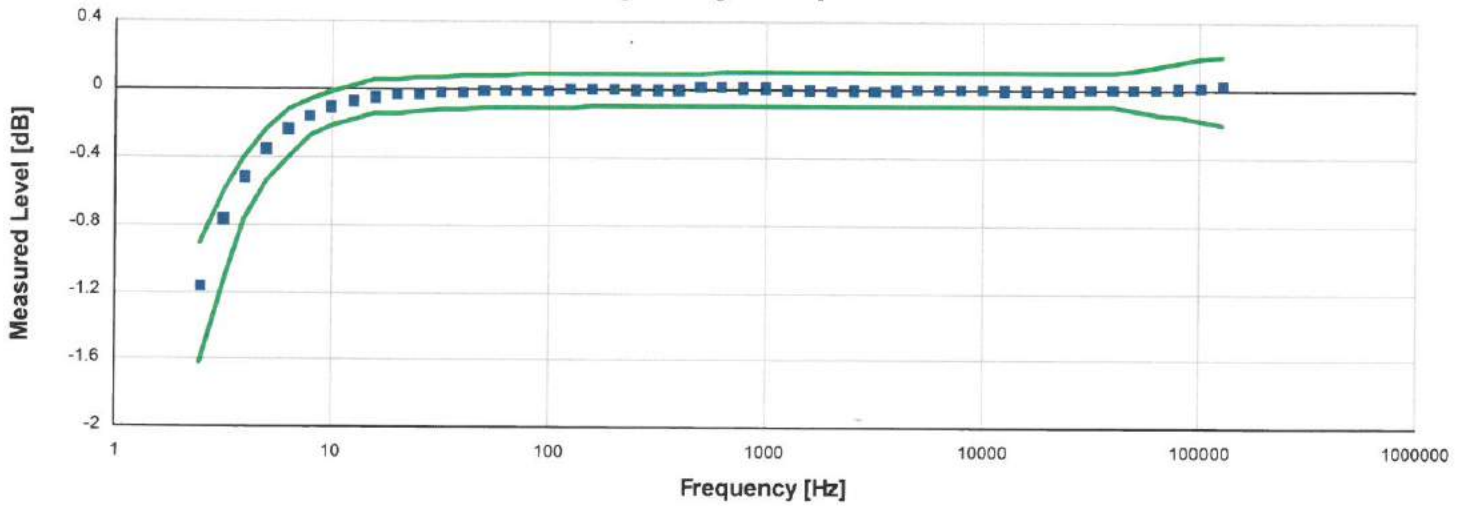

Frequency response electrically tested at 120.0 dB re 1 μ V

Frequency [Hz]	Test Result [dB re 1 kHz]	Lower limit [dB]	Upper limit [dB]	Expanded Uncertainty [dB]	Result
2.50	-1.17	-1.62	-0.91	0.07	Pass
3.20	-0.77	-1.14	-0.60	0.08	Pass
4.00	-0.52	-0.77	-0.40	0.08	Pass
5.00	-0.36	-0.54	-0.24	0.07	Pass
6.30	-0.24	-0.40	-0.12	0.07	Pass
7.90	-0.16	-0.28	-0.06	0.07	Pass
10.00	-0.11	-0.22	-0.01	0.07	Pass
12.60	-0.07	-0.18	0.02	0.07	Pass
15.80	-0.05	-0.15	0.05	0.07	Pass
20.00	-0.03	-0.14	0.06	0.07	Pass
25.10	-0.03	-0.13	0.07	0.07	Pass
31.60	-0.02	-0.12	0.07	0.07	Pass
39.80	-0.02	-0.12	0.08	0.07	Pass
50.10	-0.01	-0.11	0.08	0.07	Pass
63.10	-0.01	-0.11	0.08	0.07	Pass
79.40	-0.01	-0.11	0.09	0.07	Pass
100.00	-0.01	-0.11	0.09	0.07	Pass
125.90	0.00	-0.11	0.09	0.07	Pass
158.50	0.00	-0.10	0.09	0.07	Pass
199.50	0.00	-0.10	0.09	0.07	Pass
251.20	0.00	-0.10	0.09	0.07	Pass
316.20	0.00	-0.10	0.09	0.07	Pass
398.10	0.00	-0.10	0.09	0.07	Pass
501.20	0.01	-0.10	0.09	0.07	Pass
631.00	0.01	-0.10	0.10	0.07	Pass
794.30	0.01	-0.10	0.10	0.07	Pass
1,000.00	0.01	-0.10	0.10	0.07	Pass
1,258.90	0.00	-0.10	0.10	0.07	Pass
1,584.90	0.00	-0.10	0.10	0.07	Pass
1,995.30	-0.01	-0.10	0.10	0.07	Pass
2,511.90	0.00	-0.10	0.10	0.07	Pass
3,162.30	-0.01	-0.10	0.10	0.07	Pass

Larson Davis, a division of PCB Piezotronics, Inc
 1681 West 820 North
 Provo, UT 84601, United States
 716-684-0001



Frequency [Hz]	Test Result [dB re 1 kHz]	Lower limit [dB]	Upper limit [dB]	Expanded Uncertainty [dB]	Result
3,981.10	0.00	-0.10	0.10	0.07	Pass
5,011.90	0.00	-0.10	0.10	0.07	Pass
6,309.60	0.00	-0.10	0.10	0.07	Pass
7,943.30	0.00	-0.10	0.10	0.07	Pass
10,000.00	0.00	-0.10	0.10	0.07	Pass
12,589.30	0.00	-0.10	0.10	0.07	Pass
15,848.90	0.00	-0.10	0.10	0.07	Pass
19,952.60	0.00	-0.10	0.10	0.07	Pass
25,118.90	0.00	-0.10	0.10	0.07	Pass
31,622.80	0.00	-0.10	0.10	0.07	Pass
39,810.70	0.00	-0.10	0.10	0.07	Pass
50,118.70	0.00	-0.12	0.12	0.08	Pass
63,095.70	0.01	-0.14	0.14	0.08	Pass
79,432.80	0.01	-0.16	0.16	0.08	Pass
100,000.00	0.02	-0.18	0.18	0.08	Pass
125,892.50	0.02	-0.20	0.20	0.22	Pass

Gain Measurement

Measurement	Test Result [dB]	Lower limit [dB]	Upper limit [dB]	Expanded Uncertainty [dB]	Result
Output Gain @ 1 kHz	-1.78	-2.60	-1.00	0.03	Pass

-- End of measurement results--

DC Bias Measurement

Measurement	Test Result [V]	Lower limit [V]	Upper limit [V]	Expanded Uncertainty [V]	Result
DC Voltage	3.30	2.90	3.80	0.01	Pass

-- End of measurement results--



1/3-Octave Self-Generated Noise

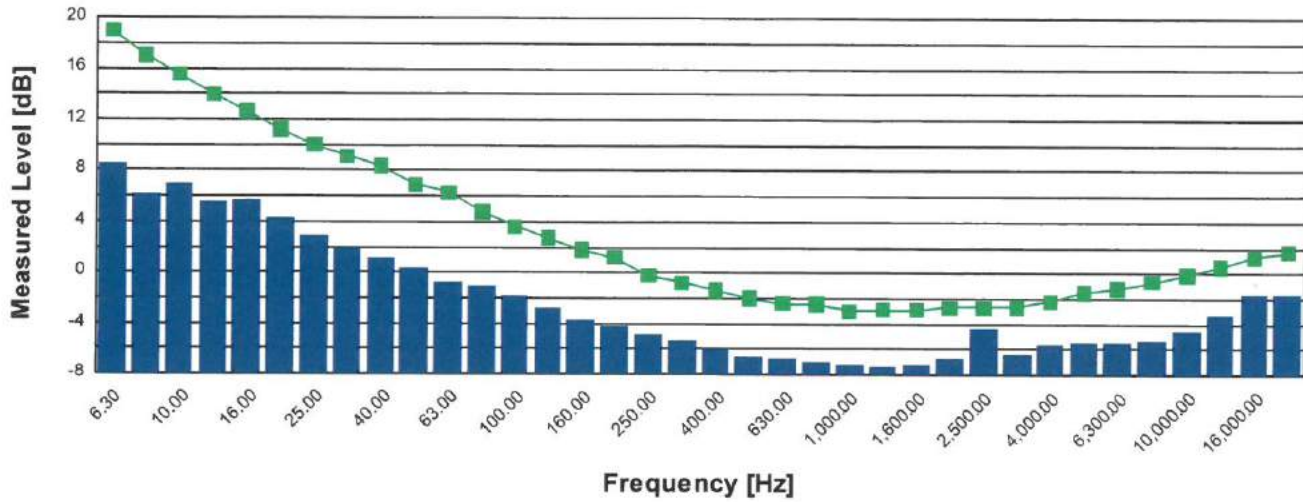

Frequency [Hz]	Test Result [dB re 1 μV]	Upper limit [dB re 1 μV]	Result
6.30	8.50	19.00	Pass
8.00	6.20	17.00	Pass
10.00	6.90	15.50	Pass
12.50	5.50	14.00	Pass
16.00	5.70	12.60	Pass
20.00	4.30	11.20	Pass
25.00	2.90	10.00	Pass
31.50	2.00	9.10	Pass
40.00	1.10	8.40	Pass
50.00	0.40	6.90	Pass
63.00	-0.70	6.30	Pass
80.00	-1.10	4.80	Pass
100.00	-1.90	3.60	Pass
125.00	-2.80	2.70	Pass
160.00	-3.70	1.80	Pass
200.00	-4.20	1.20	Pass
250.00	-4.80	-0.20	Pass
315.00	-5.30	-0.80	Pass
400.00	-5.90	-1.40	Pass
500.00	-6.50	-2.00	Pass
630.00	-6.70	-2.40	Pass
800.00	-7.00	-2.50	Pass
1,000.00	-7.20	-3.00	Pass
1,250.00	-7.30	-2.90	Pass
1,600.00	-7.20	-2.90	Pass
2,000.00	-6.70	-2.70	Pass
2,500.00	-4.40	-2.70	Pass
3,150.00	-6.40	-2.60	Pass
4,000.00	-5.60	-2.20	Pass
5,000.00	-5.50	-1.50	Pass
6,300.00	-5.50	-1.20	Pass
8,000.00	-5.30	-0.70	Pass
10,000.00	-4.50	-0.10	Pass
12,500.00	-3.20	0.50	Pass
16,000.00	-1.70	1.30	Pass
20,000.00	-1.70	1.70	Pass

-- End of measurement results--



Self-generated Noise

Bandwidth	Test Result [μ V]	Test Result [dB re 1 μ V]	Upper limit [dB re 1 μ V]	Result
A-weighted (1 Hz - 20 kHz)	2.04	6.20	8.00	Pass
Broadband (1 Hz - 20 kHz)	3.98	12.00	14.00	Pass
-- End of measurement results--				

Signatory: Ron Harris

Larson Davis, a division of PCB Piezotronics, Inc
 1681 West 820 North
 Provo, UT 84601, United States
 716-684-0001

