

# ACTIVE FIRE CURTAIN BARRIER

FOR THE DOMESTIC AND  
RESIDENTIAL HOME

[WWW.COOPERSFIRE.COM](http://WWW.COOPERSFIRE.COM)



**coopers**

EST. 1983

LEADING THE WAY IN FIRE PROTECTION



# CONTENTS

Front Page	page 1
Contents	page 2
What is a Fire Curtain?	page 3
Applications	page 4
About Coopers	page 6
Before and After	page 8
Technical Details	page 10
Control Options	page 11
Third Party Certification	page 12
Buying a Fire Curtain	page 13
Product Selector	page 14
Risk Assessment	page 15
After Care Service	page 16
Additional Benefits	page 17
Help with a Quotation	page 18
Checklist (detachable)	page 19
Customer Information	page 20
Site Survey Form (detachable)	page 21
Contact Coopers	page 24



# WHAT IS A FIRE CURTAIN?

From architects to homeowners, Coopers domestic fire curtain barriers provide you with the means to help create modern, open plan living environments compliant with stringent fire regulations without compromising design. Sympathetic to interior aesthetics, the domestic fire curtain barrier will remain hidden until deployed and is used to replace non-loadbearing walls, fire doors and un-insulated glazing.

Increasingly specified by designers as an integral component for facilitating open plan environments, Coopers fire curtains are the modern alternative to heavy and cumbersome fire doors and is an aesthetically pleasing replacement for traditional, industrial looking shutters.



## WHAT A FIRE CURTAIN CAN REPLACE?

- Wall
- Door
- Glazing
- Serving Hatches
- Ceiling

## FIRE CURTAIN APPLICATION

- Kitchen
- Hall & Lobby
- Loft & Cellar
- Laundry Shoot
- Serving Hatches
- Protecting non fire rated glazing forming a boundary protection
- Walls and floors forming a protective means of escape
- Skylight or Roof Lantern



# APPLICATION

Coopers commitment to life safety has led us to develop a wide range of fire and smoke curtains approved to protect every type of building application.

You may wish to remove a wall and require a vertical fire curtain to protect a means of escape or install a horizontal fire curtain for compartmentation.

Our fire curtains provide a modern, non-invasive alternative to traditional fire protection.



LOFT AND CELLAR



WALL AND FLOORS (PROTECTED MEANS OF ESCAPE)



KITCHEN

STAIRWAYS  
(PROTECTED MEANS  
OF ESCAPE)

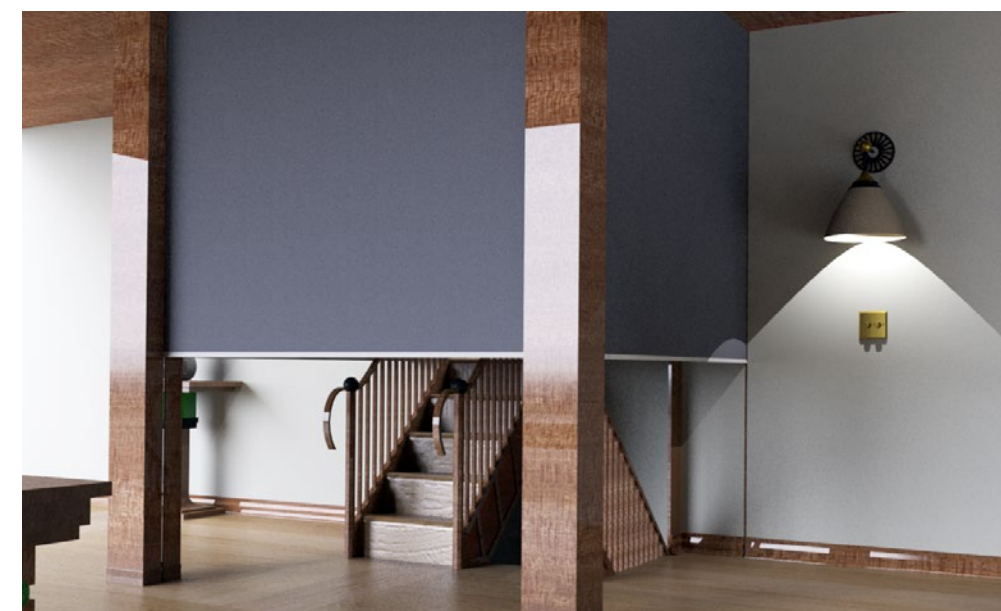



# COOPERS FIRE LTD.

Coopers Fire Limited is a British company manufacturing fire and smoke curtain barrier systems in the United Kingdom for installation worldwide. Coopers invented and patented the Gravity Fail Safe (GFS) Smoke and Fire Curtain, which has become the benchmark for most smoke and fire curtain systems sold around the world today.

Due to the high performance and reliability of Coopers products, they have been specified and installed in some of the world's landmark buildings like Buckingham Palace and Sydney Opera House.

COOPERS FIRE LTD. IS A SPECIALIST MANUFACTURER OF SMOKE AND FIRE CURTAIN BARRIER SYSTEMS.



# COMPANY PROFILE

At Coopers, we're proud of the fact that every fire and smoke curtain and their key components are manufactured within the Cooper Group of Companies to ISO 9001 and ISO 14001 at our manufacturing plants in the United Kingdom.



## ABOUT COOPERS

Coopers are dedicated to advancing fire and smoke barrier curtain technology and improving ways to safeguard life and property.

This commitment to developing innovative products that are robustly tested and independently certified has meant that Coopers has become the benchmark used by Regulators, Architects, Engineers and other Fire Professionals worldwide.

## COMPLIANCE AND STANDARDS

At Coopers, our commitment to life safety is best expressed through our dedication to ensuring that our fire and smoke curtains meet the highest accreditations and standards.

This means that we test and manufacture every fire and smoke curtain in accordance with the toughest of internationally recognised accreditations, instilling our clients with confidence in fire protection equipment that they can trust.





# BEFORE AND AFTER

The Coopers FireMaster fire curtain is an active fire curtain barrier that remain invisibly retracted until activated by an alarm or detector signal, at which time they descend safely to their fire operational position. The standard fabric used offers 120 minutes integrity.

AFTER

Controls are custom made to be fully compatible with both existing alarm systems and the number of barrier units installed, whether single or multiple roller assemblies.

When an alarm signal is detected, the control panel will automatically trigger all the Barrier systems to deploy by controlled descent using our unique Total Gravity Fail-Safe (TGFS) system.



THE ORIGINAL FIRE RATED BARRIER SOLUTION PROVIDING FIRE RATING FOR OPENINGS UP TO 30M WIDE

BEFORE



AFTER



# TECHNICAL DETAILS

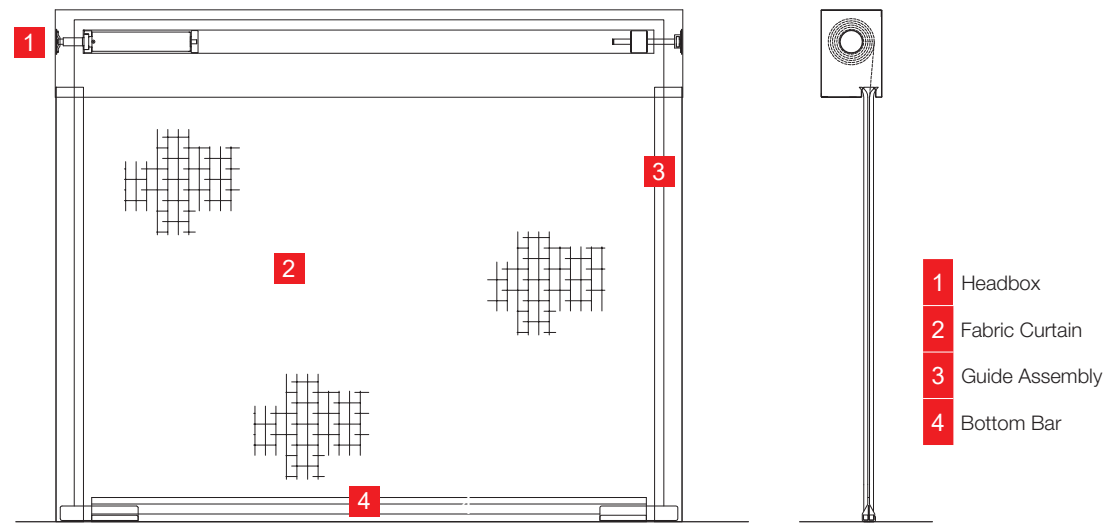

## VERTICAL CURTAIN

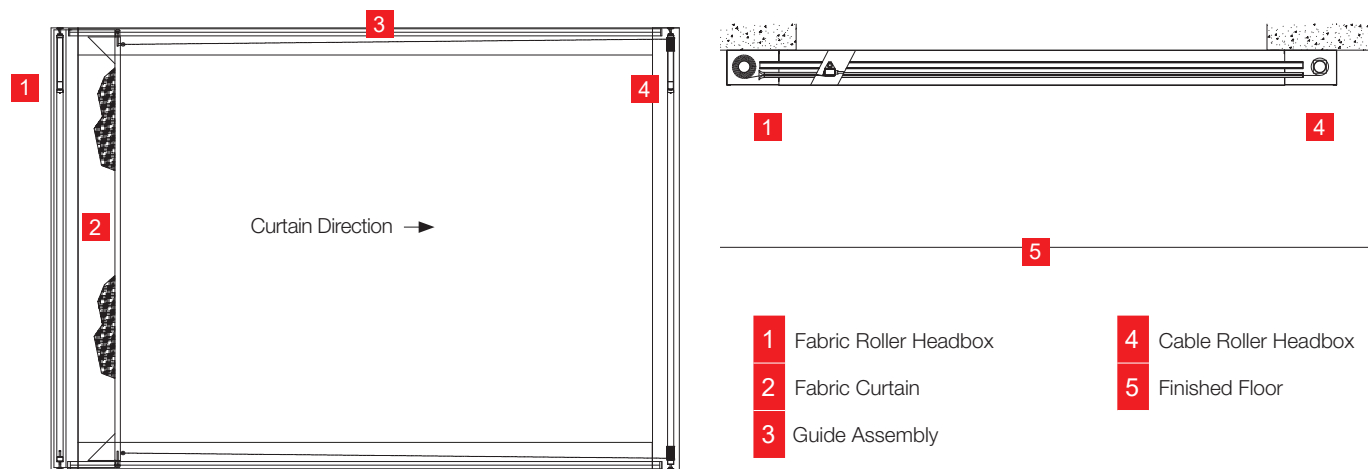

## HORIZONTAL CURTAIN

# CONTROL OPTIONS

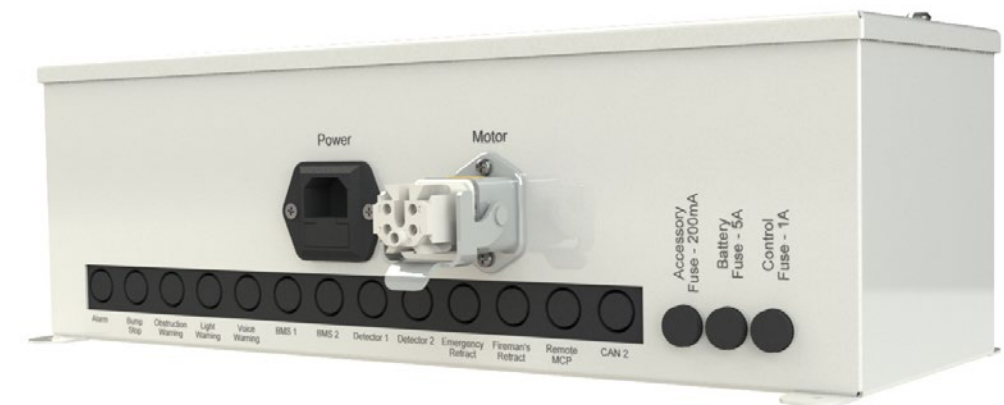
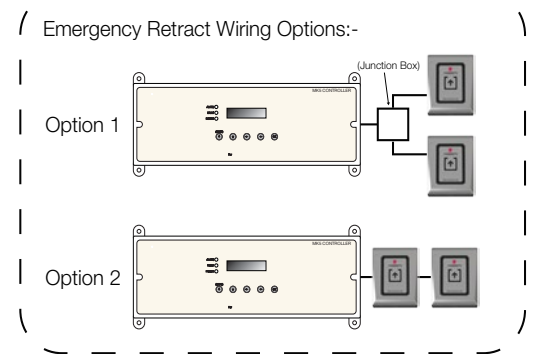
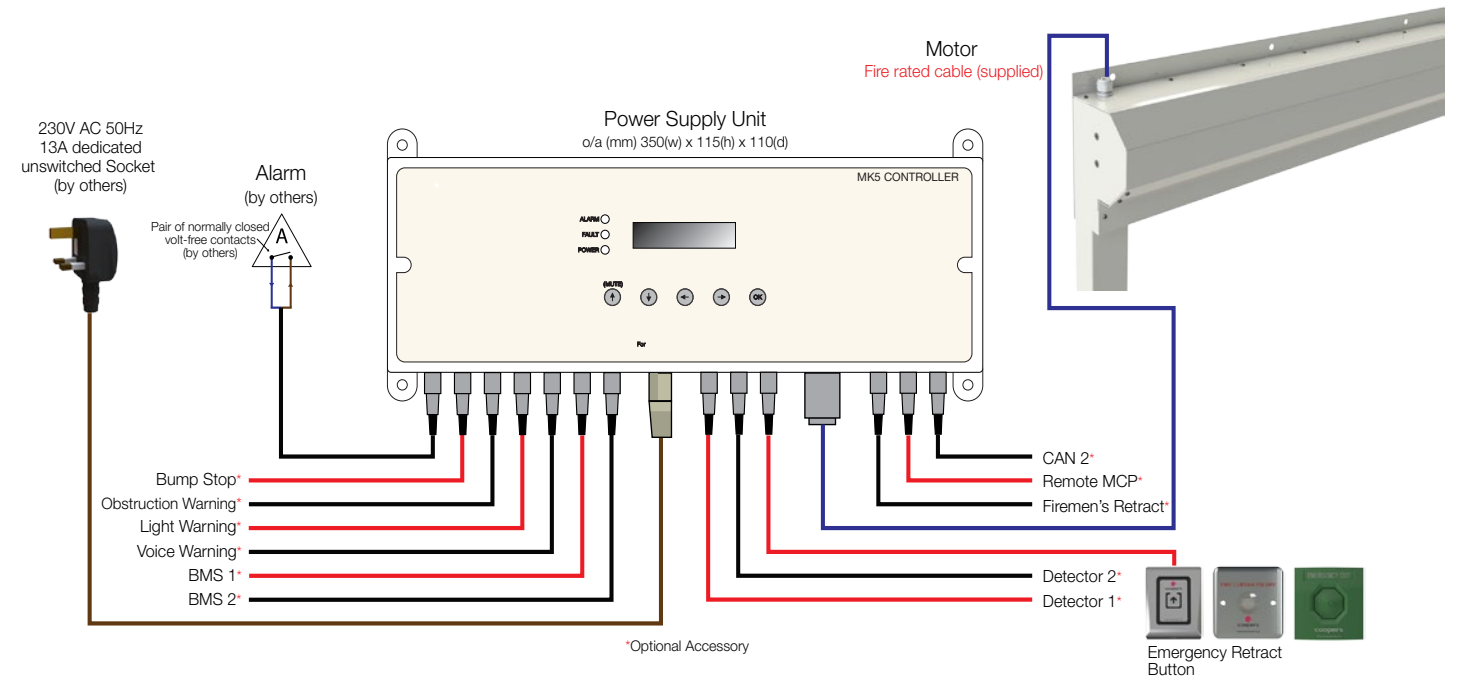

## MK5 CONTROL BOX



# THIRD PARTY CERTIFICATION



IFC Certification Ltd is a UKAS accredited and internationally recognised provider of high quality and customer focused third party certification. Coopers Fire are Third Party Certified by the IFC for our range of Active Fire Curtain Barrier Assembly products, as well as an Installer of Passive Fire Protection. IFC website: [www.ifccertification.com](http://www.ifccertification.com)

**PFI 031** Certified Installer of Passive Fire Protection

**IFCC 1015** Product Certification of Active Fire Curtain Barrier Assemblies

**IFCC 1016** Product Certification of Active Fire Curtain Barrier Assemblies

**FSB 411.04** Product Certification of Active Fire Curtain Barrier Assemblies

# BUYING A FIRE CURTAIN

## 1. WHY WOULD I NEED A FIRE CURTAIN FOR MY HOME?

Your home is legally required to comply with stringent fire regulations designed to help protect you and your family from the deadly effects of fire and smoke. This legislation states that:

1. Your home needs to maintain a protected means of escape and / or;
2. Provide an effective means to compartmentalise a room or lobby (over a defined size) to contain a fire.

Enforced by a Building Control Body, meeting these regulations will determine whether your extension, renovations or new building project meets Building Control Approval.

## 2. WHAT STANDARD AND COMPLIANCE DO I NEED?

Standards are your best means of ensuring your fire curtain will protect you in the event of a fire. **If the fire curtain does not carry the correct certification, then it's very likely that it hasn't been tested to the correct standards, putting both your home and its occupants at risk.**

Furthermore, if the fire curtain doesn't meet the correct standards, your projects will fail to meet building control approval.

1. For protecting a means of an escape, it's vital that your fire curtain meets with PAS 121 and is certified to provide an Insulating Zone or tenable area. This stringent requirement is specifically designed to provide any occupants evacuating a building with protection from heat radiation.

2. If replacing a non-loadbearing wall, then ask for evidence that the fire curtain has achieved PAS 121 standards in accordance with BS EN certification.

3. Compartmentation of a large basement or kitchen/dining room again meet PAS 121 standards and must provide the required minutes protection from fire.

For advice on your project, it's important that you seek the professional advice of your appointed Approved Building Control Authority before you contact a fire curtain supplier.

## 3. SHOULD I SEEK DIRECTION FROM MY BUILDING CONTROL AUTHORITY?

Before you contact a fire curtain supplier, it's necessary to seek the advice of your appointed Building Control Body. This will quickly help you to establish the correct specification of the fire curtain you require and is the first step to guaranteeing that your project meets fire regulations.

Once you have a specification, which may include details regarding retractable button, smoke control and voice warning systems, it's time to contact a reputable supplier for a quotation.

## 4. WHAT IS TOTAL GRAVITY FAIL-SAFE AND DOES MY FIRE CURTAIN NEED IT?

Total Gravity Fail Safe or TGFS is a backup system designed to ensure that your fire curtain deploys to a closed position, even if your property suffers a power failure or mains short circuit.

For a fire curtain to be compliant with stringent fire regulations, TGFS must be fitted. TGFS systems are required by BS PAS 121 and its key to ensuring your fire curtain meets Building Authority approval.

## 5. WHAT HAPPENS AFTER MY FIRE CURTAIN HAS BEEN INSTALLED?

Much like a gas safety certificate, the organisation responsible for installing and commissioning your fire curtain is required to issue you with the correct certification. This commissioning certificate is to certify that your fire curtain has met the stipulated standards and has been installed by a third party approved installer and operates to fire regulations.

**It is this documentation that Building Control Authorities and insurers commonly ask for for proof of regulatory compliance.**

# PRODUCT SELECTOR

This table should help assist you with the type of product required.

PRODUCT	APPLICATION					
	DOOR	WALL	CEILING	LOBBY	BOUNDARY	MEANS OF ESCAPE
<b>ViiFire (&lt;3m x 3m)</b>						
Integrity	✓			✓		
Integrity & Smoke	✓	✓		✓		
<b>ViiFire i-Zone (&lt;3m x 3m)</b>						
Integrity & Insulating Zone	✓			✓	✓	✓
Integrity, Insulating Zone & Smoke	✓	✓		✓	✓	✓
<b>FireMaster (&lt;5m x 4m)</b>						
Integrity	✓			✓		
Integrity & Smoke	✓	✓		✓		
<b>FireMaster Plus (&lt;4m x 4m)</b>						
Integrity & Insulating Zone	✓			✓	✓	✓
Integrity, Insulating Zone & Smoke	✓	✓		✓	✓	✓
<b>Horizontal Mini Simplex (&lt;5m x 5m)</b>						
Integrity			✓			
Integrity & Insulating Zone			✓			
Integrity, Insulating Zone & Smoke			✓			✓

# RISK ASSESSMENT

When planning a new build or a refurbishment, early consultation with a fire consultant can save a lot of time and money. Coopers can refer a proven expert fire assessor.



## NEED A FIRE RISK ASSESSMENT?

GCH SAFETY

Geoffrey Harris  
Fire Consultant

t. 01322 862884  
m. 07747 013202

e. geoff\_safety.uk@aol.co.uk  
w. www.safety-uk.org

a. 147 Main Road,  
Sutton-At-Hone, Dartford  
Kent, DA4 9HW

## TO ASSIST IN THE FIRE RISK STRATEGY AND ASSESSMENT YOU SHOULD PROVIDE:

- A description of the building
- House or Flat, type of construction e.g. timber; type of roof e.g. tiled (a photograph of the front of the premises would be beneficial)
- How many floors has the building, if a flat/maisonette which floors does it occupy?
- Basement levels?
- Loft conversion, planned use?
- Floor plans of the building, including measurements. Show proposed open plan areas/use
- Access to the rear of the building or enclosed?
- Alternative Fire Escape?



## AFTER CARE SERVICE

A fire curtain installed in your home is part of a 'Life Safety System' and once your manufacturer's warranty has expired, it is important to consider the ongoing maintenance of the equipment to ensure it remains in a fully operative state. Current Building Regulations and the Fire Safety Order place the responsibility on the occupier to ensure that all curtains are inspected regularly. Infringements may lead to prosecution.

Coopers Fire offer a specialist after care package that can be tailored to your specific requirements, by our dedicated service division. A number of aftercare products are available ranging from annual service inspections to a fully comprehensive total care package.

Our engineers can attend at, six monthly or annual intervals and all servicing is performed at pre arranged times to ensure the minimum of disruption. A programme of routine tests, check and adjustments is carried out which identifies any obvious problems, enabling appropriate remedial work to be planned, thereby reducing the need for more costly 'Emergency Call Outs'.

All our engineers are factory trained at our in house training facility and participate in an ongoing development scheme. Our fleet of service vehicles are fully equipped and carry a comprehensive range of spare parts to enable on the spot repairs in most instances.

PLANNED SERVICE IS AVAILABLE FOR  
COOPERS FIRE LIFE SAFETY EQUIPMENT

### SERVICE AND MAINTENANCE INFORMATION

If you would like to discuss your service requirements, or would like to request a no obligation quotation, please call free phone 0800 633 5224 or 02392 454 405 or email [service@coopersfire.com](mailto:service@coopersfire.com)

## ADDITIONAL BENEFITS

### BUILDING CONTROL APPROVAL GUARANTEE

**Coopers Fire guarantees that your installation will be approved by Building Control.**

Coopers Fire are happy to get in contact with the authority that will underwrite your project. This is so we understand in the early stages what the fire curtain requirements are. Once understood, we can then advise on suitable products and quote accordingly.

Coopers Fire has never had an installation rejected by any Building Control body and guarantees that your installation will be approved by local Building Control or Approved Inspector or we'll give you your money back!

### INSURANCE DETAILS

**Insurance Compliant.**

Coopers Fire is the only company in the UK to be independently accredited and registered by a UKAS accredited certification body. Coopers are covered for Employers Liability, Public and Products Liability and Professional Indemnity.

**Employers Liability: £10,000,000**  
**Public and Products Liability:**  
**£10,000,000**

### BANK REFERENCE

**We can provide a bank reference to support any advanced payments and deposits.**

Coopers Fire have been trading for over 30 years but if you require further assurance that your money is safe, we can provide you with a pre-paid Bank reference application that will help ensure absolute peace of mind.

### VAT ZERO RATING

**Work on ordinary homes may be applied with reduced-rated or zero-rated VAT.**

Much of the work that builders and similar trades-people do is standard-rated. But some types of work can be reduced-rated or zero-rated if certain conditions are met.

Fire and Smoke curtains are treated the same as the construction of the building rather than a fixture and fitting and therefore fall into the category of reduced-rated or zero-rated VAT where applicable.

## HELP WITH A QUOTATION

Coopers Fire can help you with a quotation by filling in some of the information that follows on the next four pages.

### CHECKLIST

By asking your Building Control Officer or Approved Inspector to complete the Checklist will help us to understand what type of fire curtain you require.

### CUSTOMER INFORMATION

The Customer Information will be used to stay in contact with you and also helps us to help you specify the correct curtain in working with your local Building Authority and / or your Building Control Officer or Approved Inspector.

### SITE SURVEY FORMS

The Site Survey Forms are for a vertical fire curtain or a horizontal fire curtain. Please, fill in whichever is applicable to you.

The pages are perforated to easily detach and return to Coopers Fire (printed version only).

### CONTACT DETAILS

Coopers Fire Ltd.  
Edward House  
Penner Road  
Havant  
Hampshire  
PO9 1QZ

Email: info@coopersfire.com  
Phone: 02392 454 405

## CHECKLIST

CURTAIN REQUIREMENTS	YES	NO
<b>PROTECT MEANS OF ESCAPE</b> If occupants will pass along side the barrier / curtain it will need to either insulated or have an insulation zone. Escape route width need to be increased by the zone depth.	<input type="checkbox"/>	<input type="checkbox"/>
<b>INTEGRITY AND INSULATING ZONE</b>	<input type="checkbox"/>	<input type="checkbox"/>
<b>INTEGRITY ONLY</b>	<input type="checkbox"/>	<input type="checkbox"/>
<b>SMOKE LEAKAGE</b>	<input type="checkbox"/>	<input type="checkbox"/>
<b>PROVIDE COMPARTMENTATION</b>	<input type="checkbox"/>	<input type="checkbox"/>
<b>TIME OF FIRE RESISTANCE</b> 20 minutes 30 minutes 60 minutes	<input type="checkbox"/> <input type="checkbox"/> <input type="checkbox"/>	<input type="checkbox"/> <input type="checkbox"/> <input type="checkbox"/>
<b>OTHER TIME (INSERT REQUIREMENT)</b>	<input type="checkbox"/>	<input type="checkbox"/>
<b>OBSTRUCTION PREVENTION / WARNING (IF REQUIRED)</b> Markings Detection	<input type="checkbox"/> <input type="checkbox"/>	<input type="checkbox"/> <input type="checkbox"/>
<b>DEPLOYMENT WARNING</b> Signage, e.g. directional sign Beacon and audible or voice warning Photo-luminescent	<input type="checkbox"/> <input type="checkbox"/> <input type="checkbox"/>	<input type="checkbox"/> <input type="checkbox"/> <input type="checkbox"/>
<b>REMOTE OPENING SWITCHES</b> Press button hold on Press button latched Fireman's over ride Beam, e.g. radar and/or pressure pad	<input type="checkbox"/> <input type="checkbox"/> <input type="checkbox"/> <input type="checkbox"/>	<input type="checkbox"/> <input type="checkbox"/> <input type="checkbox"/> <input type="checkbox"/>
<b>DETECTION / ACTIVATION TYPE</b> Heat detector (usually for compartmentation - non means of escape) Smoke detector (usually for protecting means of escape)	<input type="checkbox"/> <input type="checkbox"/>	<input type="checkbox"/> <input type="checkbox"/>
<b>DEPLOYMENT POWER</b> Gravity Fail Safe (GFS) is a UK requirement for life safety Powered e.g. mains (for non life safety applications and horizontal only)	<input type="checkbox"/> <input type="checkbox"/>	<input type="checkbox"/> <input type="checkbox"/>
<b>BARRIER MOVEMENT</b> Immediate single movement Immediate multiple staged movement Delayed deployment Delayed deployment multiple staged movement	<input type="checkbox"/> <input type="checkbox"/> <input type="checkbox"/> <input type="checkbox"/>	<input type="checkbox"/> <input type="checkbox"/> <input type="checkbox"/> <input type="checkbox"/>
<b>SELF TESTING FACILITY</b>	<input type="checkbox"/>	<input type="checkbox"/>

MAINTENANCE TESTING	FREQUENCY
Check for obstructions to operational area of insulating zone, e.g. by cosmetic finishes, lighting, shelving, sofas and armchairs	Daily
All barrier types shall be operated at least once a month	Monthly



# CUSTOMER INFORMATION

Name \_\_\_\_\_

Address \_\_\_\_\_

\_\_\_\_\_

\_\_\_\_\_

Telephone Number \_\_\_\_\_

E-Mail \_\_\_\_\_

Who is your local Building Authority or Approved Inspector? \_\_\_\_\_

What is the name of your Building Control Officer or Approved Inspector? \_\_\_\_\_

\_\_\_\_\_

# SITE SURVEY FORM

for quotation purposes only

For internal use only. \_\_\_\_\_

Curtain no.: \_\_\_\_\_

Location: \_\_\_\_\_

Headbox: \_\_\_\_\_

Controls: \_\_\_\_\_

Painting: \_\_\_\_\_

## VERTICAL FIRE CURTAIN

Left Hand Motor       Right Hand Motor

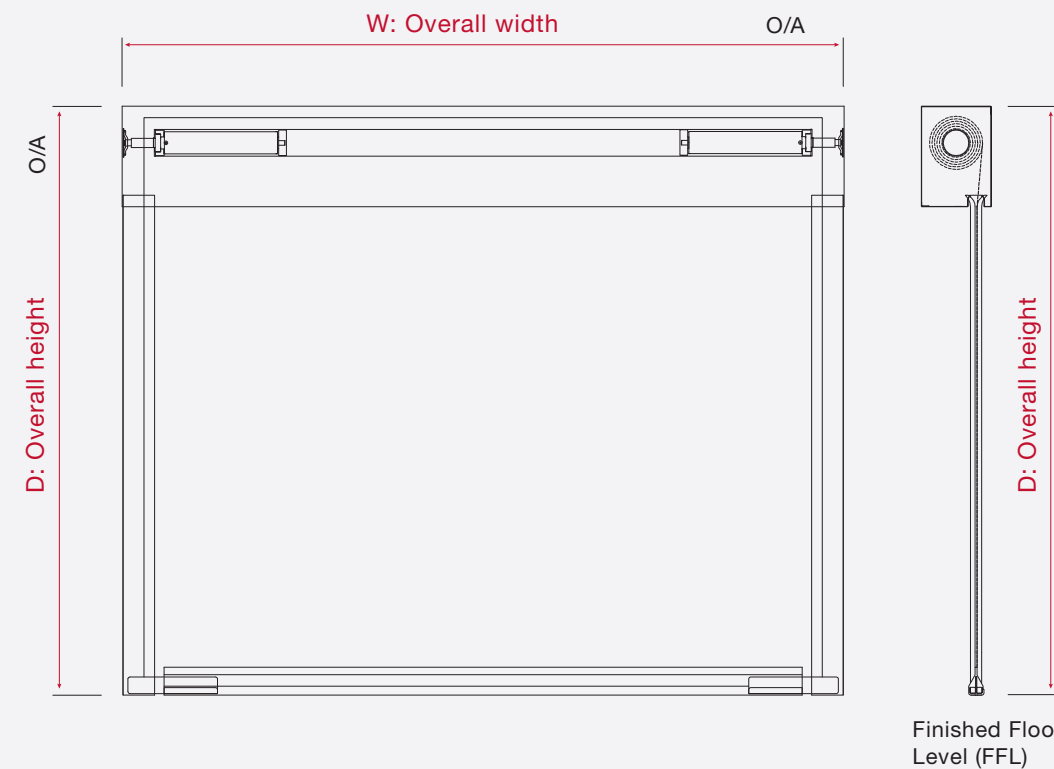
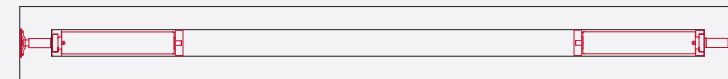

Curtain Sizes

W: \_\_\_\_\_

D: \_\_\_\_\_

Project: \_\_\_\_\_

Customer Name: \_\_\_\_\_

Ref: \_\_\_\_\_

Date: \_\_\_\_\_

Customer Print: \_\_\_\_\_

Customer Sign: \_\_\_\_\_

Date: \_\_\_\_\_

# SITE SURVEY FORM

for quotation purposes only

For internal use only. \_\_\_\_\_

Curtain no.: \_\_\_\_\_

Location: \_\_\_\_\_

Headbox: \_\_\_\_\_

Controls: \_\_\_\_\_

Painting: \_\_\_\_\_

## HORIZONTAL FIRE CURTAIN

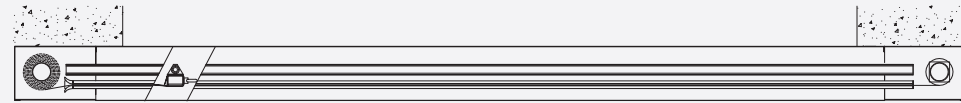

D: Overall depth O/A



Curtain

D: \_\_\_\_\_

W: \_\_\_\_\_

Project: \_\_\_\_\_

Customer Name: \_\_\_\_\_

Ref: \_\_\_\_\_

Date: \_\_\_\_\_

Customer Print: \_\_\_\_\_

Customer Sign: \_\_\_\_\_

Date: \_\_\_\_\_



For information, to get a quote  
or to book a CPD workshop

Please call:

**+44 (0)2392 454 405**

or E-mail: [info@coopersfire.com](mailto:info@coopersfire.com)  
[WWW.COOPERSFIRE.COM](http://WWW.COOPERSFIRE.COM)

Coopers Fire Ltd,  
Edward House, Penner Road,  
Havant, Hampshire, PO9 1QZ  
United Kingdom

Phone: +44 (0)2392 454 405

Fax: +44 (0)2392 492 732

Email: [info@coopersfire.com](mailto:info@coopersfire.com)

Web: [www.coopersfire.com](http://www.coopersfire.com)

Coopers Fire Ltd has a policy of  
continuous product improvement.

As such we reserve the right to  
change design and specifications  
without prior notice.

Please check our website for the  
latest information.

© Coopers Fire Ltd. All content and products are copyright  
of Coopers Fire Ltd. Registered in England Number: 2010274.  
Multiple patents granted and pending.

Series 2 v03 April 2018



LEADING THE WAY IN FIRE PROTECTION