

Elevation

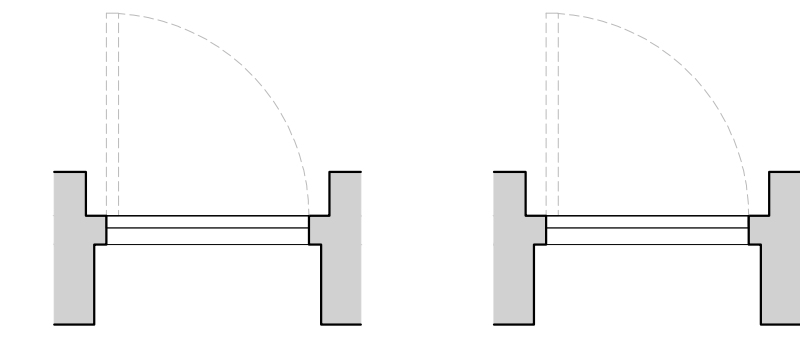

Plan
 Note:
 Existing timber 4-panel door to be replaced with single panel timber framed double glazed door.

Door Type A - -1.01

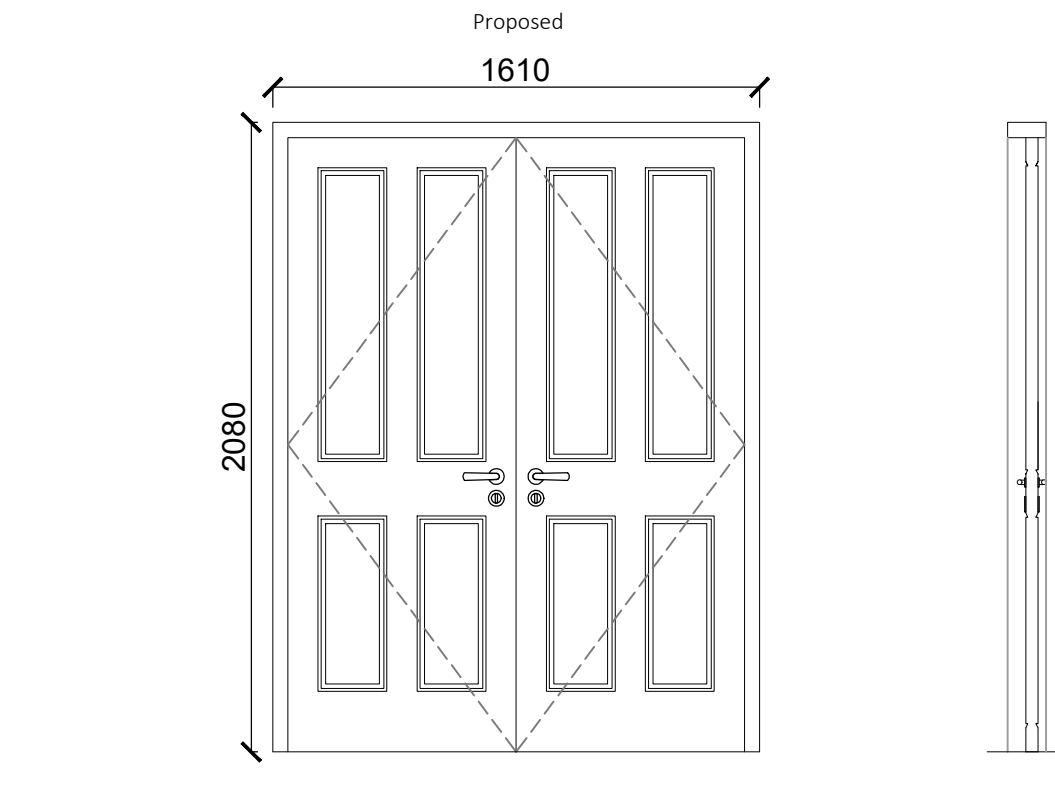

Elevation

Section

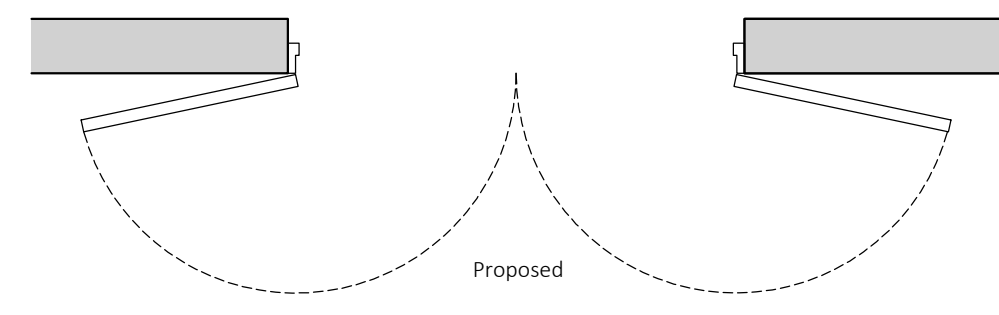

Plan
 Note:
 New opening formed and installation of new double 4-panel doors.

Door Type B - 00.01

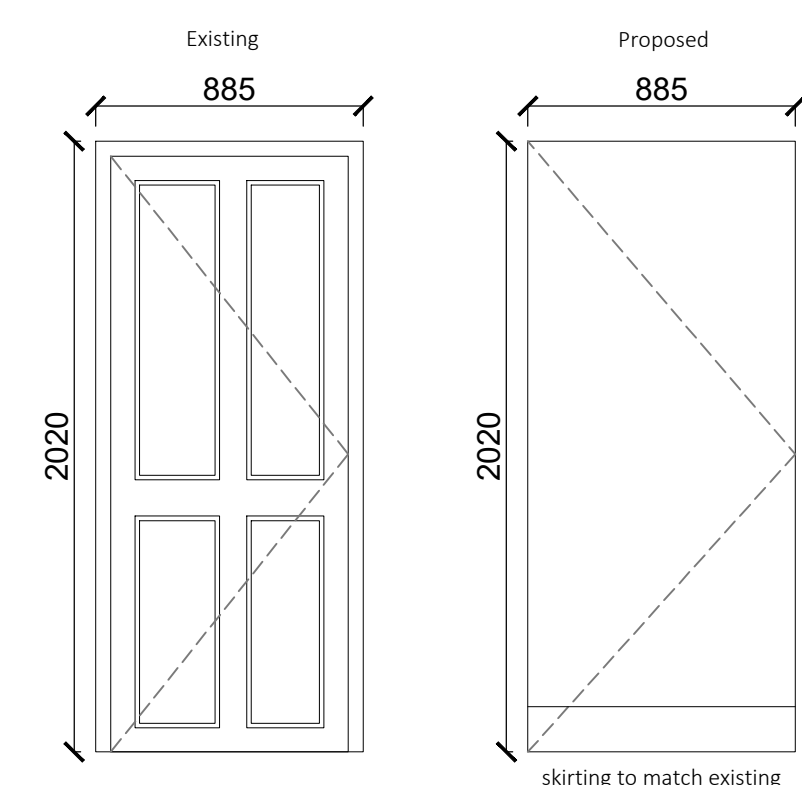

Elevation

skirting to match existing

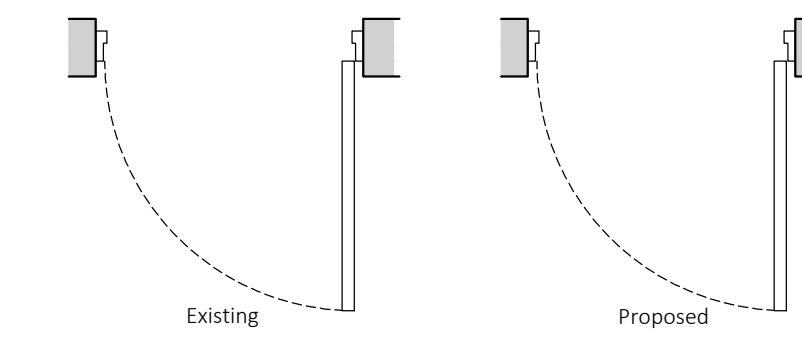

Plan
 Note:
 Replace existing 4 panel timber door with new jib door.

Door Type C - 00.02

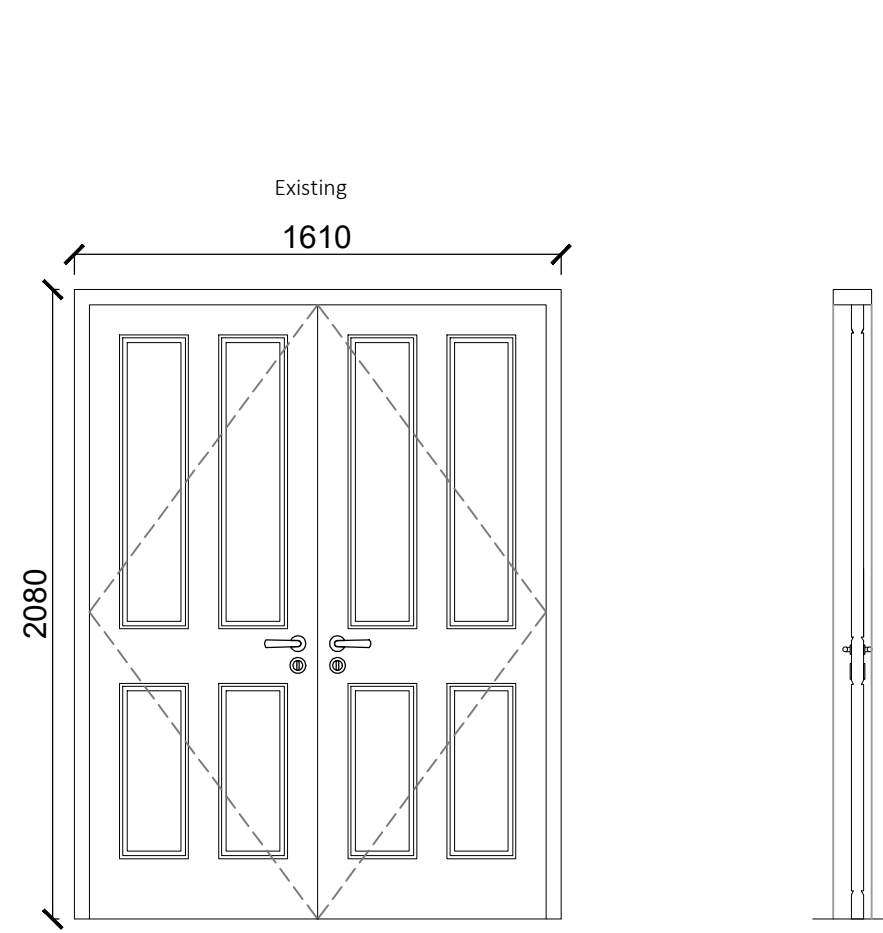

Elevation

Section

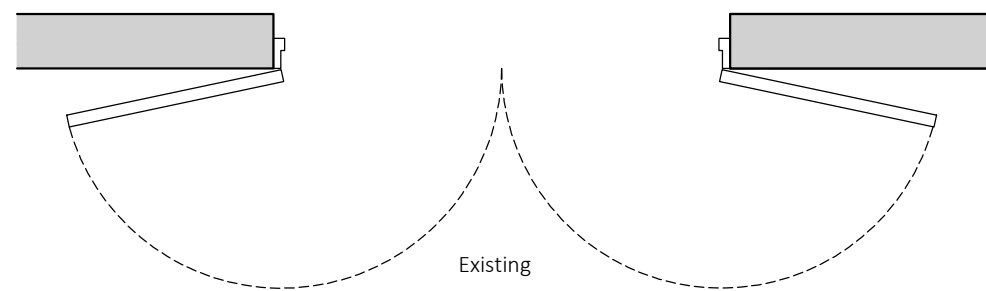

Plan
 Note:
 Existing double 4-panel doors to be removed.
 Existing door frame and architrave to be retained.

Door Type A - 00.03

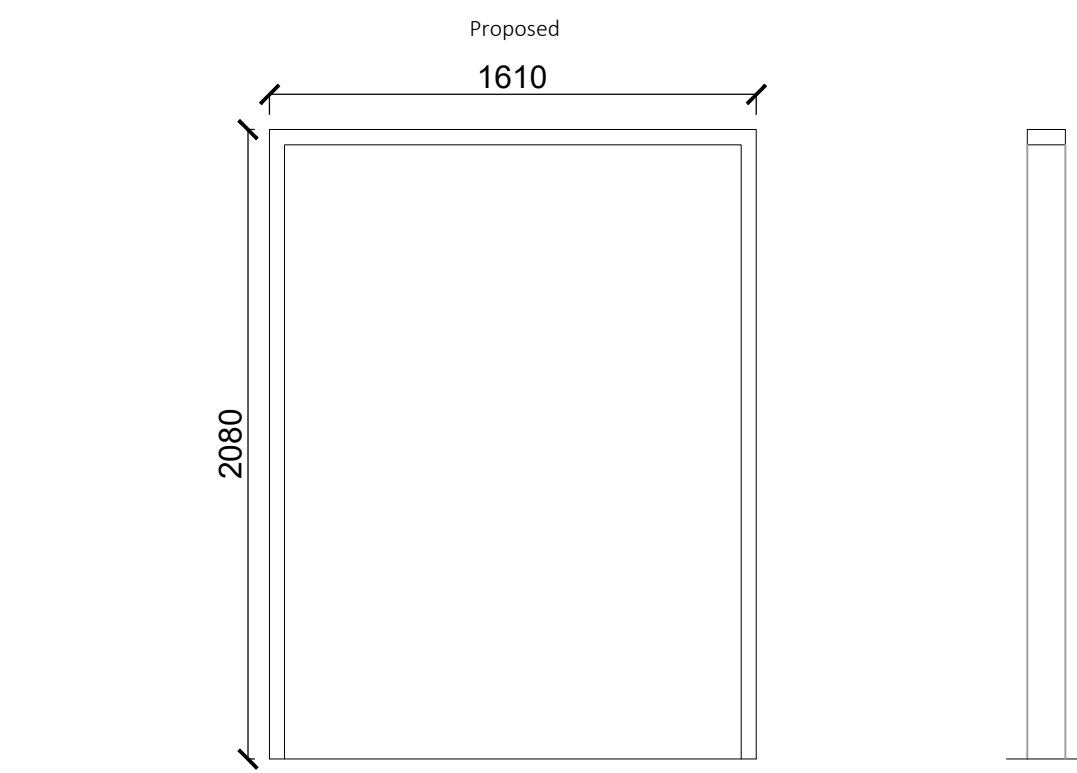

Elevation

Section



Plan
 Note:
 New plain double jib door to inside of existing front door.
 54mm thick with acoustic core.

Door Type E - 00.04

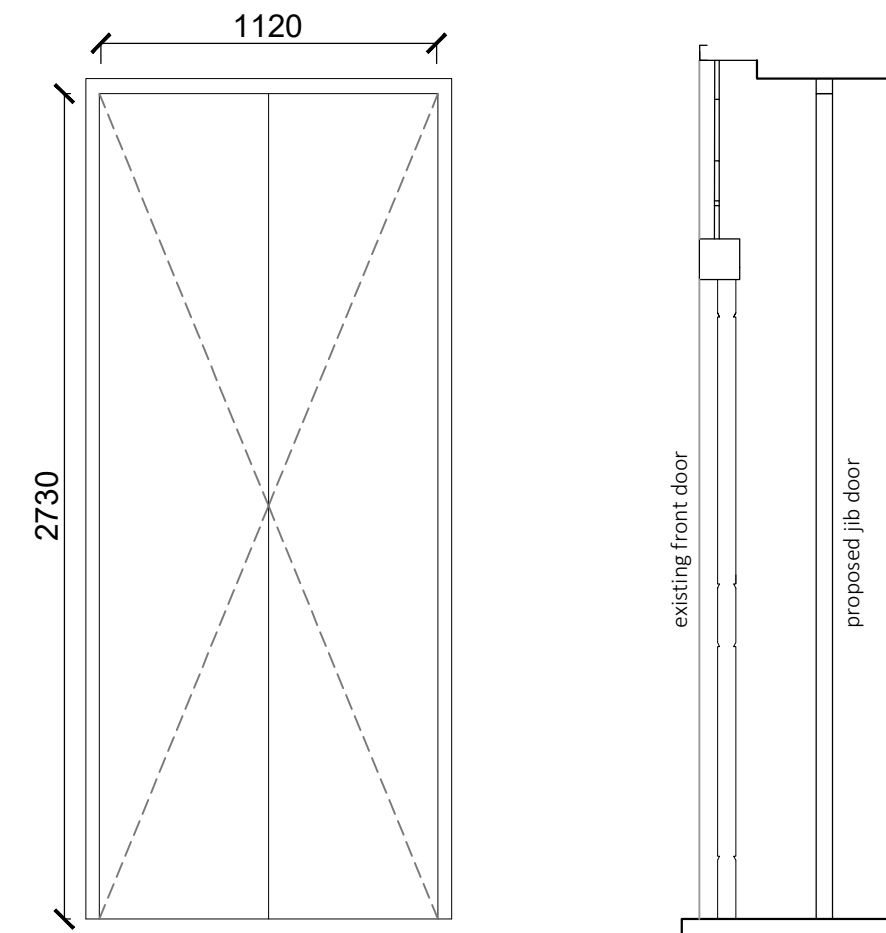

Elevation

Section

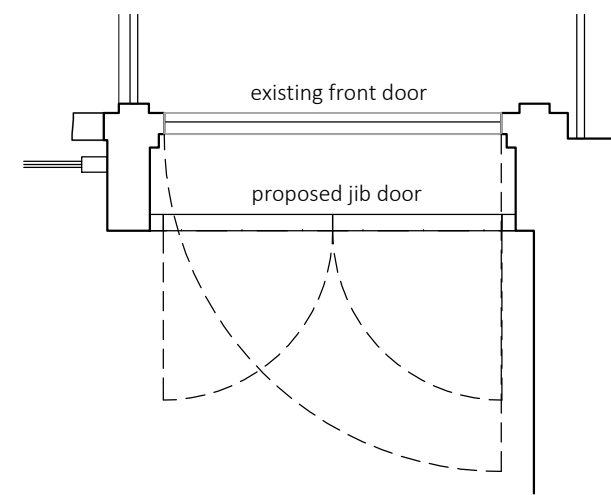

Plan
 Note:
 New plain double jib door to inside of existing front door.
 54mm thick with acoustic core.

Door Type E - 00.04

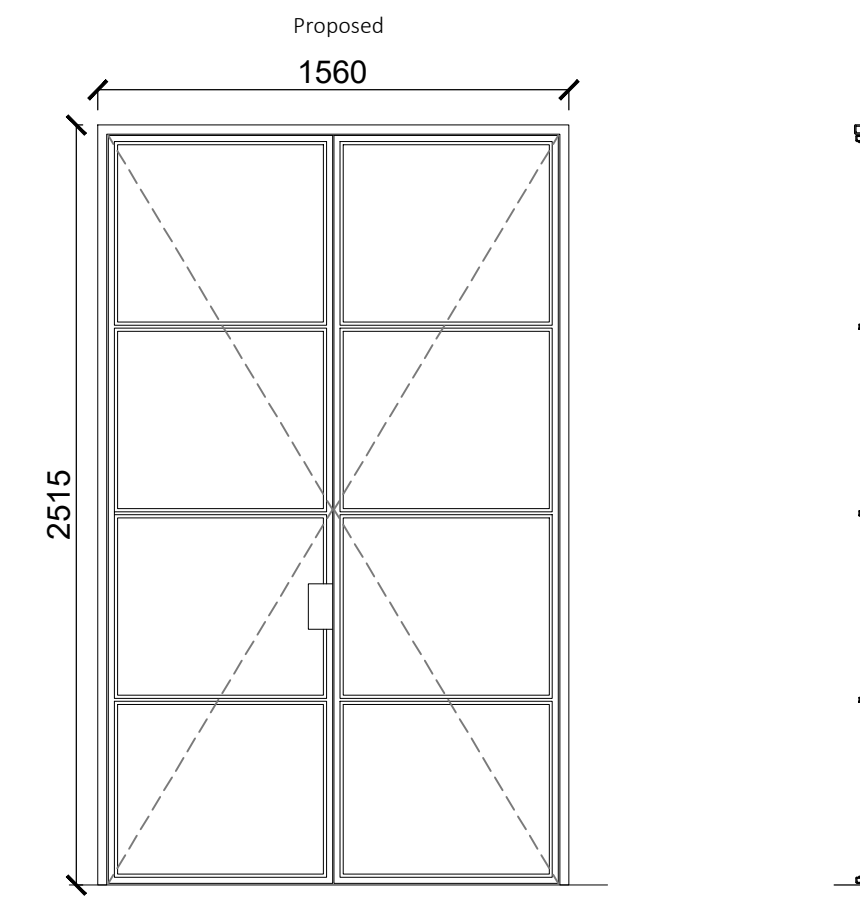

Elevation

Section

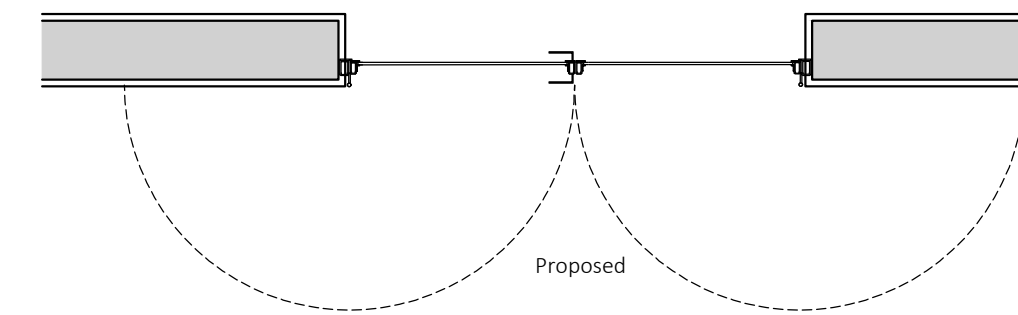

Plan
 Note:
 New metal framed Crittal doors to be installed to existing wall opening.

Door Type D - 01.01

| rev. | date | description | revised by | audited by |
|----------|------------|---------------|------------|------------|
| A | 2019.09.25 | For planning | HJ | HJ |
| stage | | drawing title | | |
| PLANNING | | DOOR SCHEDULE | | |

CONTRACTORS ARE NOT TO SCALE DIMENSIONS FROM THIS DRAWING

LIPTON PLANT ARCHITECTS

Seatem House
 39 Moreland St
 London
 EC1V 8BB

T +44 (0)20 7288 1333
 F +44 (0)20 7288 0333
 E mail@lparchitects.co.uk
 W www.lparchitects.co.uk

client
 West Hill Projects Ltd

project
 16 Cleveland Street
 London
 W1T 4HX

| scale | date issued | drawn by | audited by | drawing no | revision |
|----------------------|-------------|----------|------------|---------------|----------|
| 1:25 @A1 1:50 @A3 | 2019.07.12 | CC | HJ | 548.(1).6.003 | A |