

Garage Elevation (Grafton Mews)

Height of existing @ 1575mm

Height of new opening of door from courtyard to garage, raised 7 brick courses to 2100mm, new concrete lintel to match existing

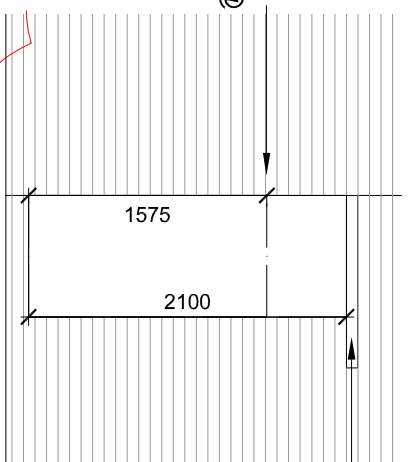

Enlarged opening to existing garage (from courtyard), 1:25 @ A1

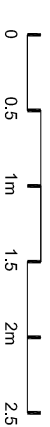

PLANNING

19/09/19 Elevation of new door opening added A

THIS DRAWING IS NOT TO BE SCALED. ONLY DIMENSIONS ARE TO BE FOLLOWED. AS IS THE DRAWING IS PART OF A PLANNING APPLICATION. CONTRACTORS ARE TO CHECK ALL DIMENSIONS BEFORE WORK COMMENCES, AND REFER ANY APPARENT DISCREPANCY TO THE ARCHITECT.
THIS DRAWING IS THE SOLE PROPERTY OF MR PARTNERSHIP LIMITED, AND MAY NOT BE COPIED OR REPRODUCED IN ANY MANNER WHATSOEVER WITHOUT THE OWNERS WRITTEN CONSENT.
(c) COPYRIGHT.

PROJECT 21 Warren Street
London

DRAWING Proposed
Side (Garage) Elevation

CH+MRP
ARCHITECTS

4142 FOLEY STREET, LONDON W1W 7TS
T: +40 207 253 2526 | +40207 631 5416
E: mail@ch-mrp.com | info@mrpartnership.co.uk
www.ch-mrp.com | www.mrpartnership.co.uk

DATE: 24/07/2019 SCALE: 1:50@A1 DRAWN: CAD
DWG No: 3213A_067 REV. No: A

FILE: 3213A_065-066 Proposed_Elevation.dwg