

Rectangular Duct Silencer Type RAAC 33

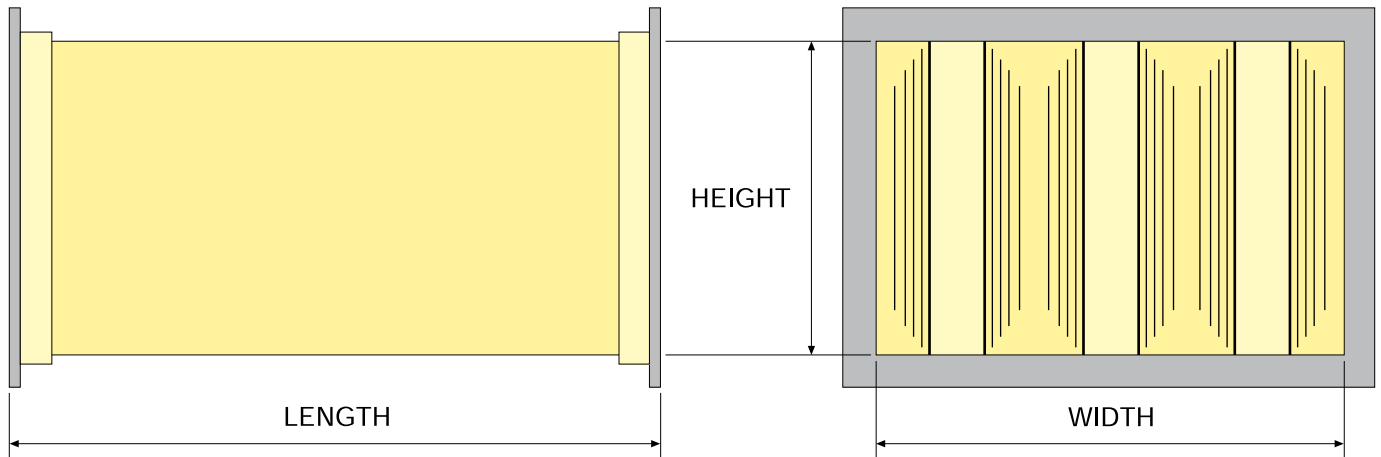

Usage

The EMTEC RAAC 33 Rectangular Duct Silencer is an absorptive baffle attenuator which converts duct-borne noise energy into thermal energy within the acoustic media contained in the baffle elements.

The RAAC Rectangular Duct Silencer range has been specifically designed for use in ducted ventilation and air conditioning systems. The main applications of RAAC silencers are the reduction of mechanical noise generated by the primary air circulation fan and the elimination of secondary regenerated noise from terminal units, mixing chambers or pressure reducing devices.

EMTEC RAAC Rectangular Duct Silencers are also used to reduce the level of external noise (aircraft, traffic etc.) entering a building, to control and contain the noise of enclosed machinery (pumps, compressors, generating sets etc.) and the elimination of speech interference, transferred by interconnecting ducting, across office walls and partitions.

Selection of the correct RAAC silencer is by subtraction of the Dynamic Insertion Loss from the source sound level with corrections being made for the natural attenuation of the duct system to obtain the established space noise criteria. EMTEC engineers are available on request to assist you in the proper selection of silencers for your particular requirements.

Construction

The EMTEC RAAC 33 Rectangular Duct Silencer has inter-baffle separation of 100mm and the individual baffle elements are 200mm wide. This gives a modular width of 300mm and with this combination gives high attenuation over a relatively short silencer length. An increase in duct cross sectional area may be required to optimise the silencer's pressure loss and self noise.

RAAC 33 Silencers are supplied with duct widths equal to any multiple of 300mm, with duct heights to suit the customer requirements and in any one of nine standard lengths (600, 900, 1200, 1500, 1800, 2100, 2400, 2700 and 3000mm).

EMTEC RAAC Standard Rectangular Duct Silencers are constructed from high quality galvanised sheet steel. The casings are lockformed and comply with the latest HVCA ductwork standard. All joints are sealed with a suitable mastic sealant and the baffle elements and end flanges are retained by sealed fixings. In this standard form EMTEC RAAC Silencers can withstand duct static pressures up to 1250 pascals. For higher static pressures the casing of the silencer is constructed from mild steel sheet, all joints being continuously seam welded.

The baffle elements contain inert, non-flammable, tissue faced mineral wool retained in a galvanised sheet steel casing. The inlet profile of the baffle is aerodynamically shaped to minimise pressure losses and the side faces of the baffle are formed from stiffened perforated metal to ensure stability and integrity of the acoustic media even under adverse airflow conditions. The acoustic media can be further protected for special applications such as supplying air to clean rooms or operating theatres or extracting from kitchens, laboratories or highly contaminated industrial process areas. For such special applications an EMTEC engineer should be consulted to establish the most appropriate treatment.

Technical Specification

EMTEC RAAC Rectangular Duct Silencers shall be installed in the positions indicated on the drawings to maintain the acoustic criteria shown in the specification. The silencers shall have galvanised sheet steel casings with drilled, mild steel end flanges. The inlet section of the baffle elements shall be aerodynamically shaped. The acoustic media shall be inert, non-flammable, tissue faced mineral wool. The acoustic media shall be retained in position by perforated, galvanised steel face sheets stiffened to maintain the integrity of the baffle element even under adverse airflow conditions.

Acoustic

Length (mm)	Dynamic Insertion Loss (dB) at Octave band centres (Hz)							
	63	125	250	500	1K	2K	4K	8K
600	4	8	15	23	33	34	33	22
900	5	9	17	27	38	40	38	26
1200	6	12	22	36	45	46	40	28
1500	6	17	28	44	47	47	42	29
1800	7	19	32	48	49	48	44	32
2100	8	21	37	50	50	50	46	35
2400	9	23	42	50	50	50	48	38
2700	10	24	44	50	50	50	50	41
3000	11	25	46	50	50	50	50	44

Duct Face Velocity (m/sec)	Silencer Self Noise in dB ref 10 ⁻¹² watts for different velocities							
	63	125	250	500	1K	2K	4K	8K
3	40	38	37	35	38	36	32	28
5	51	48	48	46	44	46	44	38
8	59	56	55	56	56	56	54	47
10	64	62	62	64	64	62	60	55

Duct Velocity (m/sec)	Corrections to D.I.L. in dB for duct velocities greater than 4 m/sec							
	63	125	250	500	1K	2K	4K	8K
+4	-2	-3	-6	-6	-6	-5	-5	-6
+8	-4	-6	-9	-9	-8	-7	-8	-8
-4	+1	+2	+2	+3	+3	+2	+1	+1
-8	+2	+2	+3	+4	+5	+4	+2	+1

+ve velocities are for noise and airflow in the same direction and -ve velocities where noise and airflow are in opposite directions

The silencer self noise levels given in the table opposite are for a face area of 0.5m². For areas greater or smaller the dB corrections shown below should be applied.

Face area (m ²)	0.1	0.25	0.75	1	3	5	10
Corrections to PWL (dB)	-7	-3	+2	+3	+7	+10	+13

Aerodynamic

It may be necessary to establish the correct size of silencer knowing that a certain pressure loss is required across the silencer for a given volume of air. In this case the duct face velocity is read off the chart opposite and the silencer dimensions established from the formula below:

$$\text{Airflow (Q)} = \text{Duct Area (A)} \times \text{Duct Face Velocity (v)}$$

Conversely for a known duct size and airflow the pressure loss across the silencer can be obtained from the chart opposite.

Selection Example:

Assuming the airflow is 5m³/sec and the maximum allowable pressure loss is 100 pascals. Assuming also that a 1200mm long silencer will meet the acoustic requirements by entering the chart opposite on the horizontal axis at 100 pascals, for a 1200mm long silencer, a duct velocity of 4.8m/sec is obtained. The duct area is then given as $A = Q/v = 5/4.8 = 1.04\text{m}^2$. If a width of 1200mm is now selected (being 4 x modular width) the height will be 900mm and the final selection will be as shown below.

EMTEC RAAC/33/1200 Silencer - 1200mm x 900mm x 1200mm long.

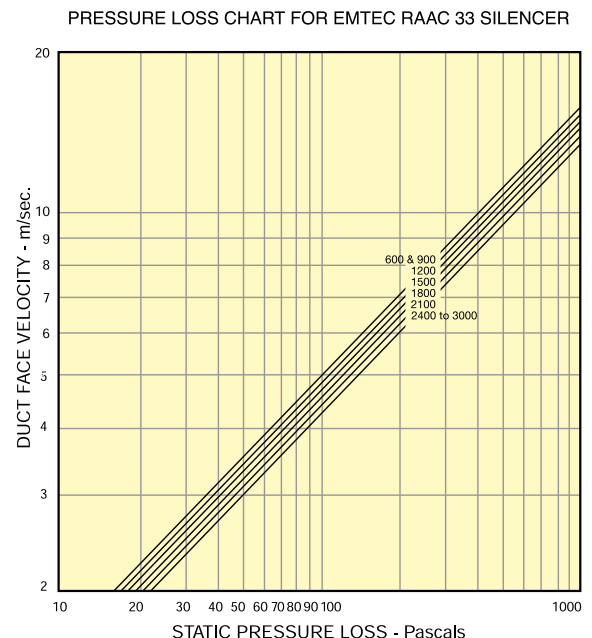

Physical

EMTEC RAAC Rectangular Duct Silencers can be positioned at any point in a ductwork system consistent with good airflow and acoustic design considerations. The silencer performance may be compromised if the flow conditions immediately before or after the silencer location are excessively turbulent. For this reason it is recommended that a minimum length of straight ducting on both sides of the silencer be allowed equal to three times the largest duct dimension. When plantroom arrangements do not allow this minimum condition then it is advisable to incorporate turning or guide vanes into the duct design to ensure that the airflow is uniform across the silencer face area.

The EMTEC RAAC 33 Rectangular Duct Silencer has an approximate volumetric weight of 175 Kg/m³. Silencers should be installed onto angle or channel supports placed at right angles to the baffle elements across the width of the silencer. When lifting an EMTEC RAAC 33 Rectangular Duct Silencer into position on site it is important to ensure that the slings used are placed around the outside of the silencer casing and the silencer lifted with the baffle elements vertical. It is imperative that silencers not be lifted by their end flanges or by slinging through the internal airway passages.

Silencers of large dimension (above a face area of 1.5m²) can be supplied in modules for on site assembly. For individual requirements please consult an EMTEC engineer.