

IF IN DOUBT ASK
DO NOT SCALE. REPORT ALL DISCREPANCIES NO MATTER HOW SMALL.

TOLERANCES UNLESS OTHERWISE STATED:

GENERAL FABRICATIONS:-
UP TO 300 + OR - (1.0mm) - 301 TO 1500 + OR - (2.0mm) OR - (1.0mm) TO 3000 + OR - (3.0mm) - 3001 TO 6000 + OR - (4.0mm) - 6001 AND ABOVE (5.0mm MAXIMUM).

FRAMEWORK:-
UP TO 300 + OR - (1.0mm)- 301 TO 1500 + (2.0m) OR - (1.0mm) - 1501 TO 3000 + (3.0mm) OR - (1.0mm) - 3001 TO 6000 + (4.0mm) OR - (1.0mm) - 6001 AND ABOVE + (5.0mm) OR - (1.0mm).

PANELS:-
UP TO 300 + OR - (1.0mm)- 301 TO 1500 + (1.0m) OR - (2.0mm) - 1501 TO 3000 + (1.0mm) OR - (3.0mm) - 3001 TO 6000 + (1.0mm) OR - (4.0mm) - 6001 AND ABOVE + (1.0mm) OR - (5.0mm).

REMOVE ALL BURRS AND SHARP EDGES.

NOTES:

- ENCLOSURE TO BE FLAT PACK CONSTRUCTION.
- DISTRIBUTION FROM THE POINT OF OFFLOAD TO THE INSTALLATION AREA IS BY OTHERS.
- ANY SCAFFOLDING / SAFE ACCESS / EDGE PROTECTION REQUIRED TO COMPLETE INSTALLATION IS TO BE PROVIDED BY OTHERS.
- ALL DIMENSIONS ARE SUBJECT TO CHANGE FOLLOWING DETAILED SITE SURVEY TO BE COMPLETED WHEN BUILDERS WORK & CLADDING DETAIL IS COMPLETE.

MATERIALS:- S235JR MILD STEEL SECTION

FRAMEWORK - S235 JR MILD STEEL SHS SECTIONS

END CAPS - BLACK MILD STEEL

BASEPLATES/TABS - BLACK MILD STEEL

TRIMS - Z275 PRE-GALV SHEET

PANELS - Z275 PRE-GALVANISED MILD STEEL C/W MINERAL WOOL INFILL TISSUE WRAPPED, & Z275 PRE-GALVANISED PERFORATED COVER

LOUVRES - Z275 PRE-GALVANISED MILD STEEL C/W MINERAL WOOL INFILL TISSUE WRAPPED, & Z275 PRE-GALVANISED PERFORATED COVER

PAD ATT - Z275 PRE-GALVANISED MILD STEEL C/W MINERAL WOOL INFILL GLASS TISSUE WRAPPED, & Z275 PRE-GALVANISED PERFORATED COVER

THE FOLLOWING ITEMS TO BE SUPPLIED UNTREATED AS PURCHASED:-

DOOR HANDLES - STAINLESS STEEL, SELF FINISH

HINGES - BRUSHED STAINLESS STEEL

FIXINGS - ALL GRADE 8.8 ZINC PLATED

FINISH:-

FRAMEWORK: - NON-VISIBLE STEELWORK TO BE HOT DIP GALVANISED TO BSEN ISO 1461 AFTER FABRICATION (UN-PAINTED)

PANELS: - VISIBLE STEELWORK TO BE PPC FINISH, STANDARD RAL COLOUR, COLOUR TBC

PAD ATTENUATOR: - PPC FINISH, STANDARD RAL COLOUR, COLOUR TBC

LOUVRE PANELS: - PPC FINISH, STANDARD RAL COLOUR, COLOUR TBC

TRIMS: - PPC FINISH, STANDARD RAL COLOUR, COLOUR TBC

QUANTITY:- - 1 ENCLOSURE REQUIRED

APPROXIMATE WEIGHT:- - 3050KGS

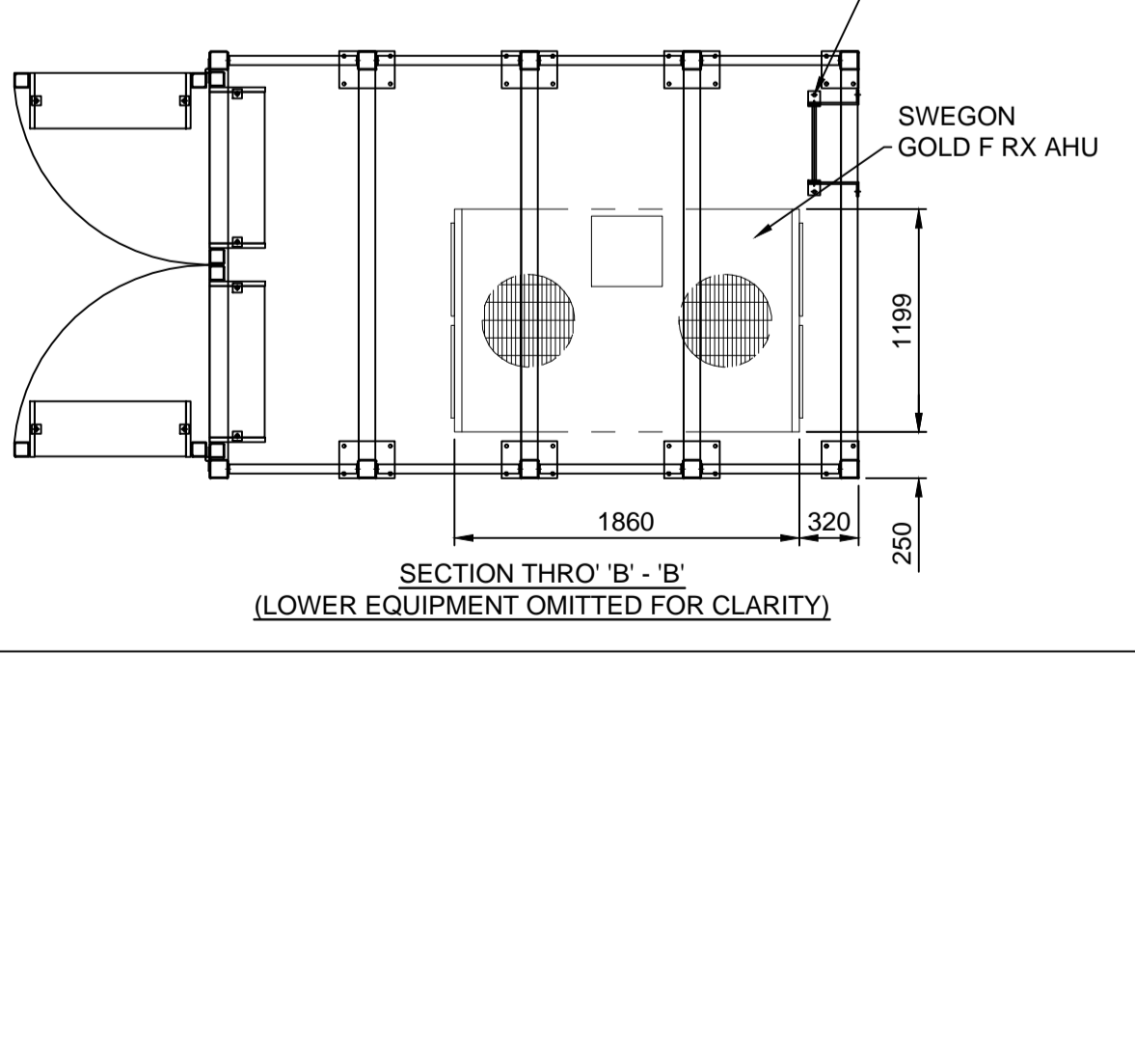
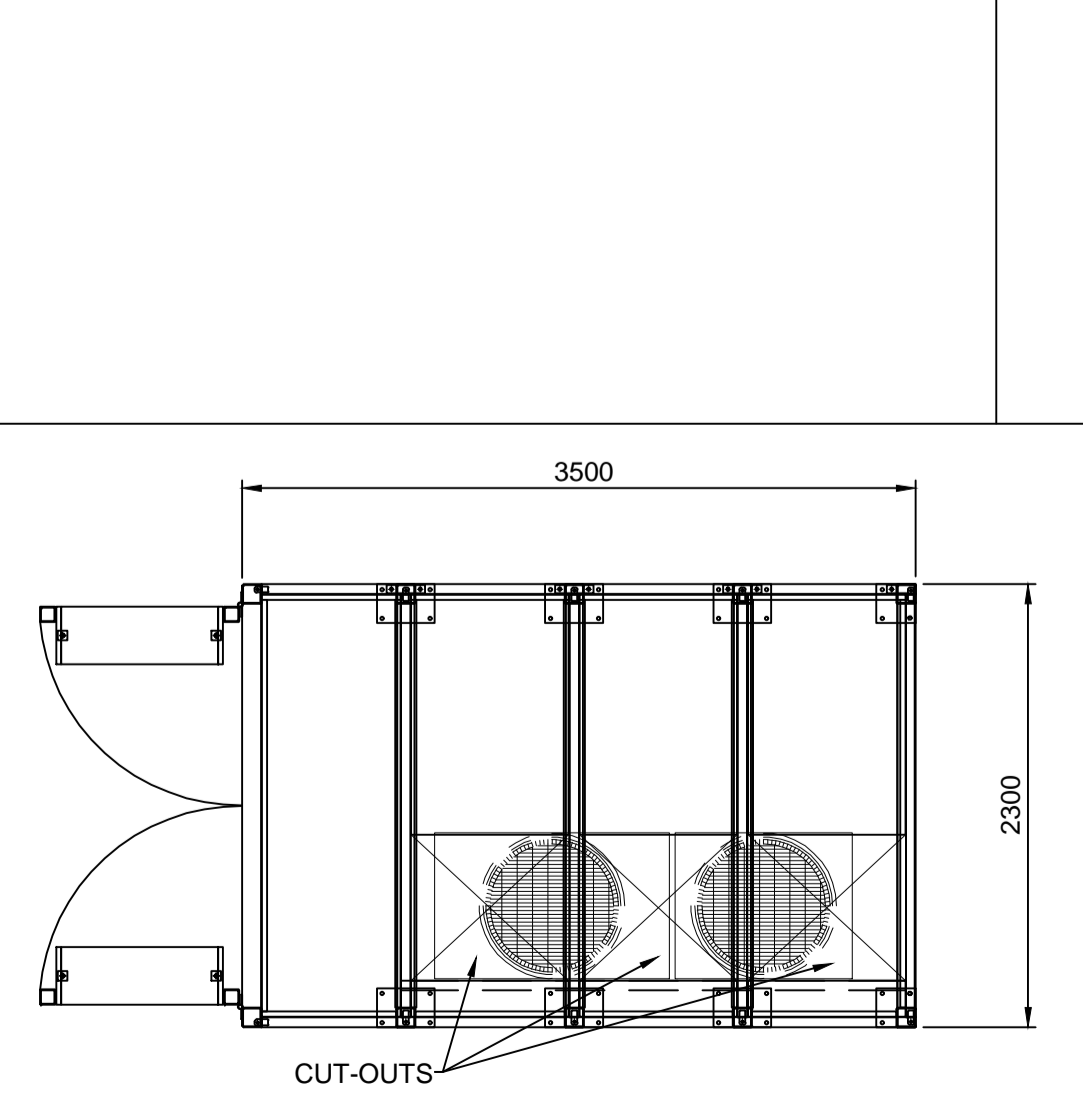
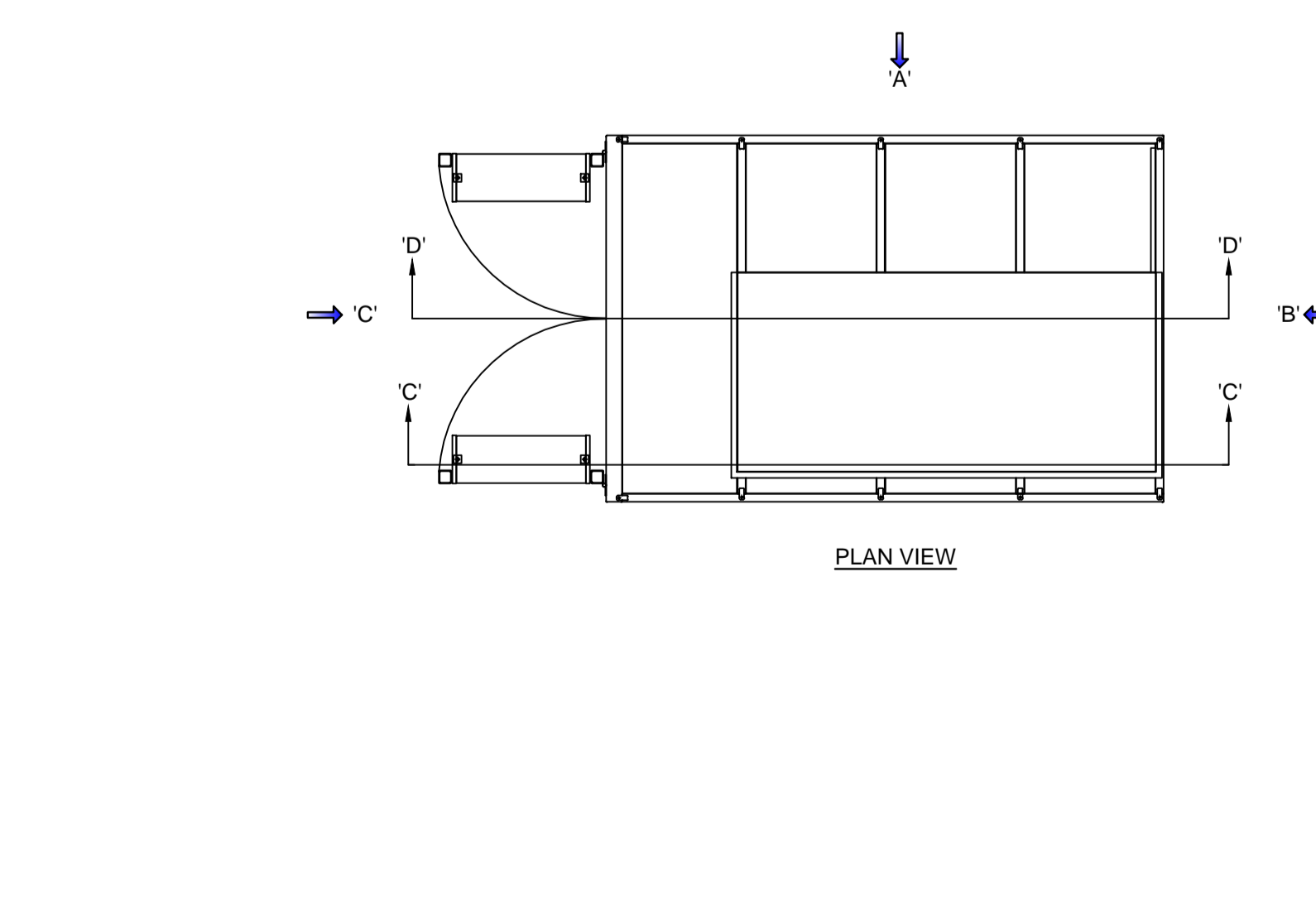
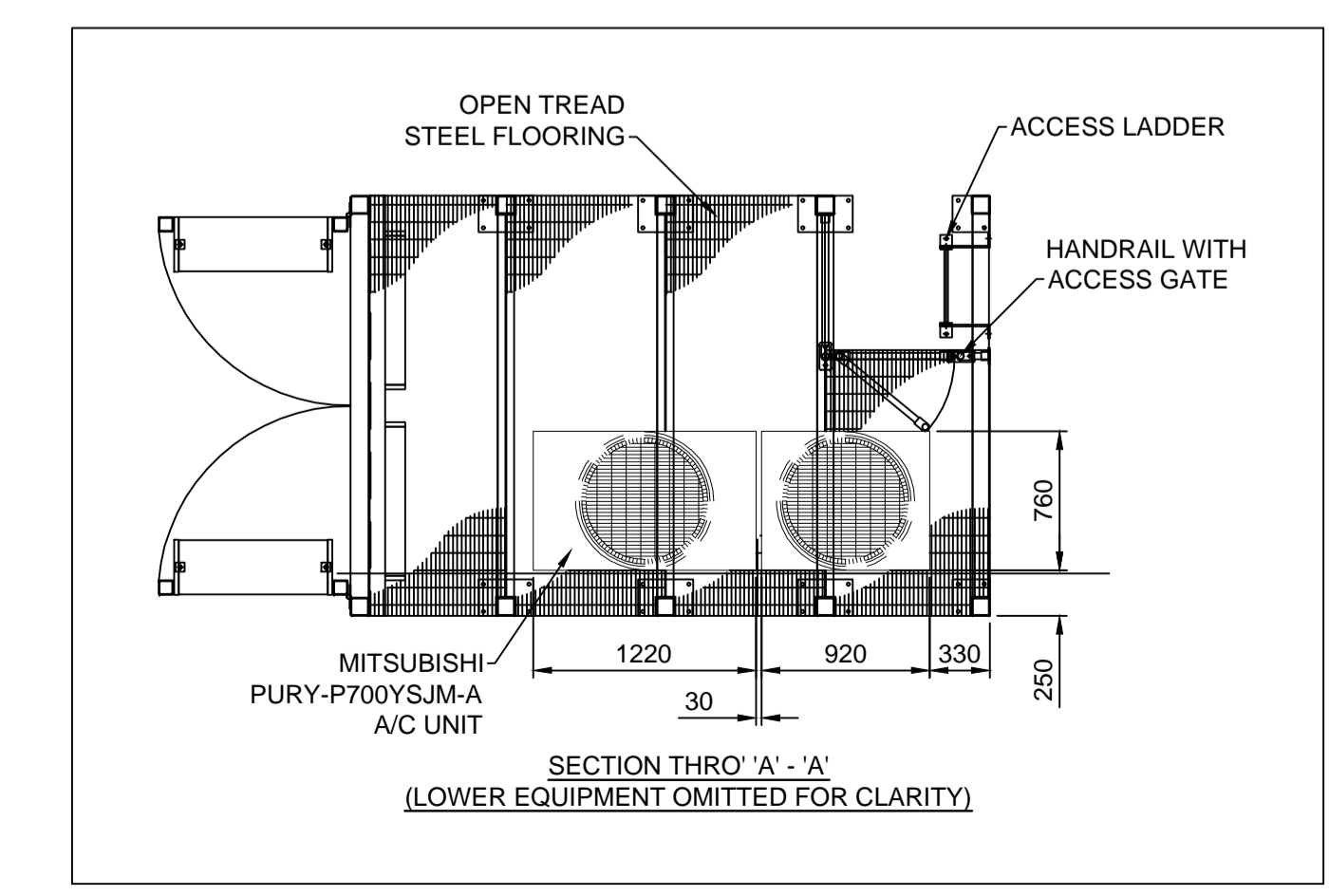
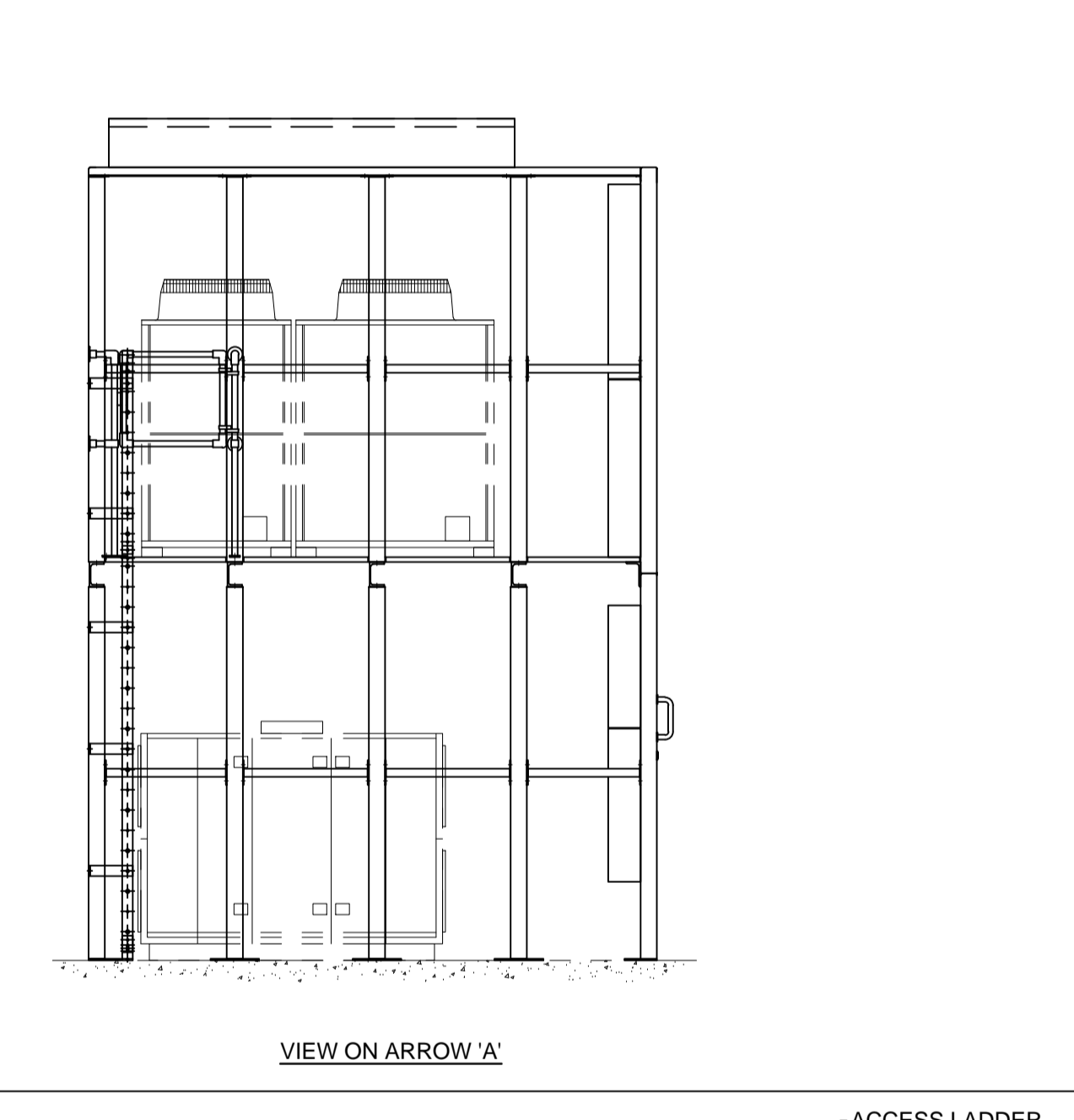
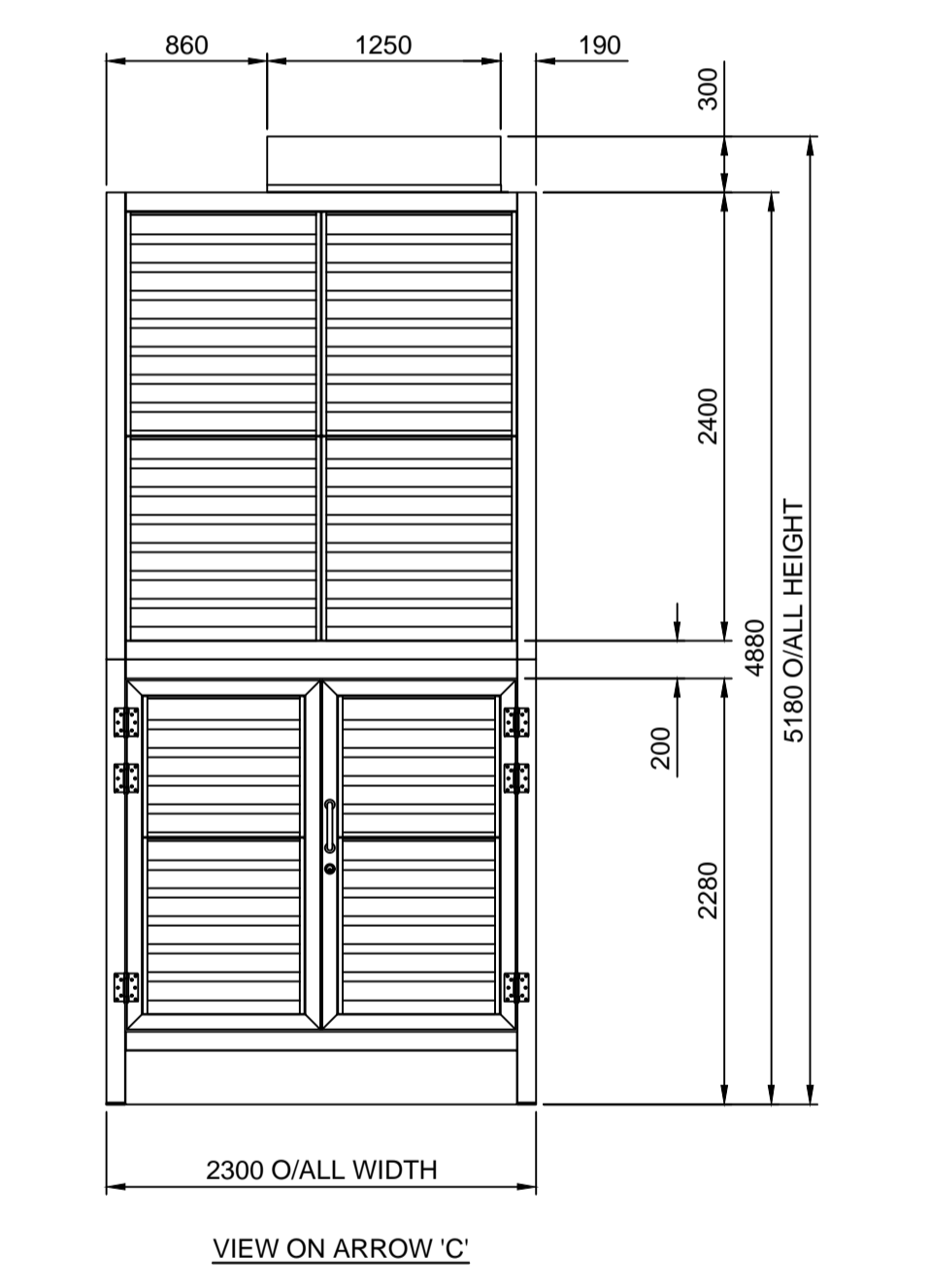
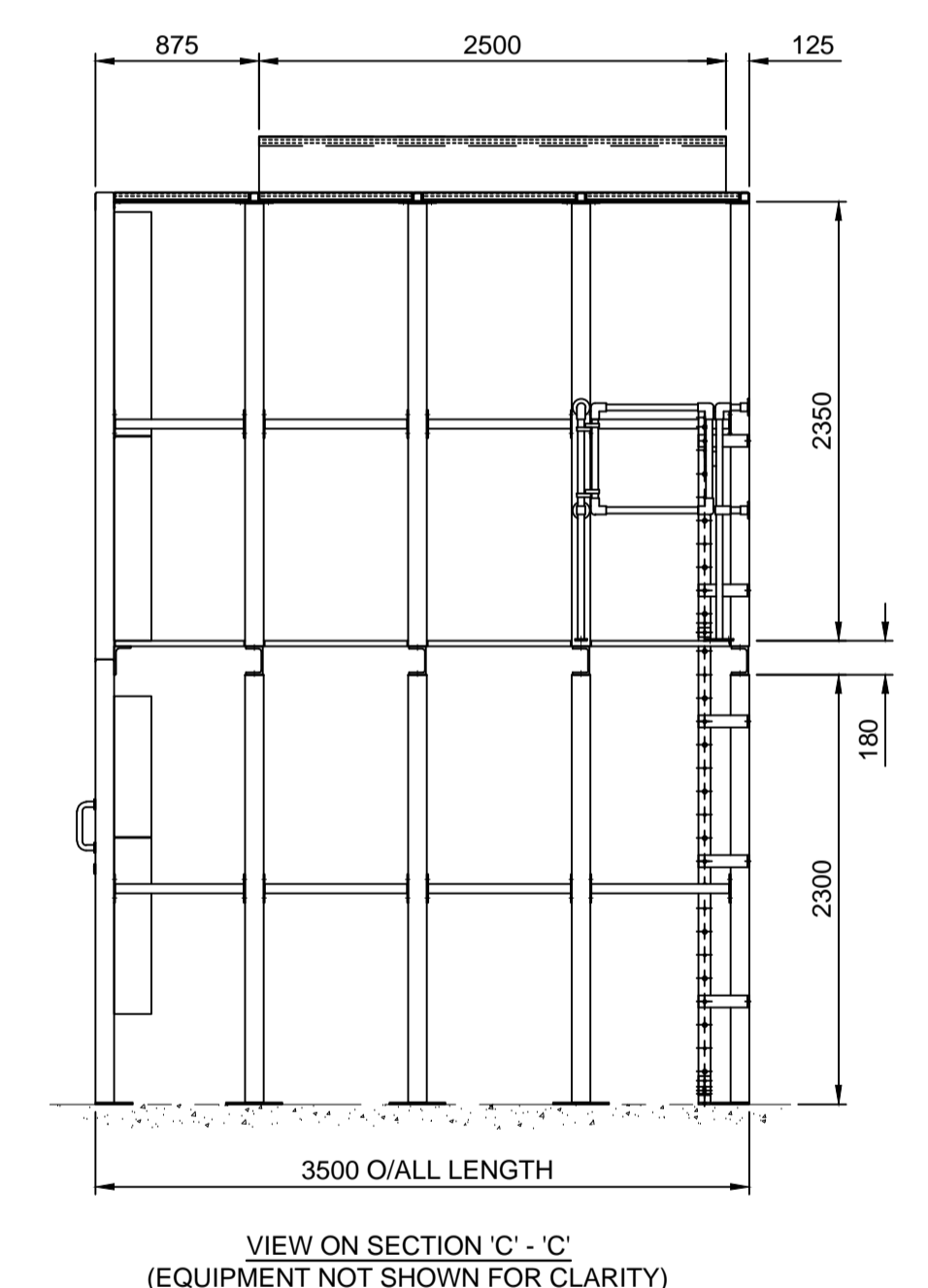
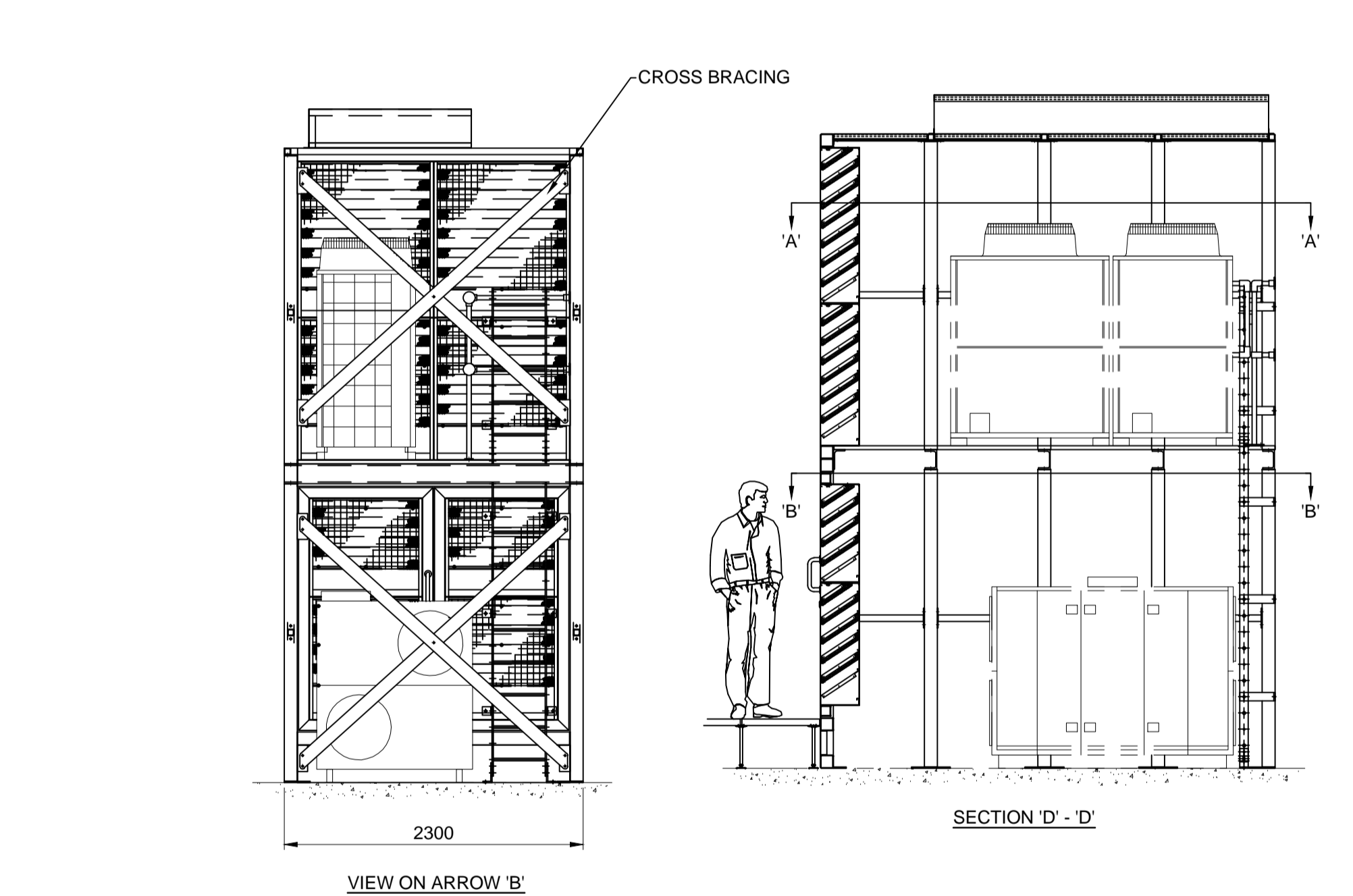

THE FOLLOWING ITEMS TO BE SUPPLIED UNTREATED AS PURCHASED:-

DOOR HANDLES - STAINLESS STEEL, SELF FINISH

HINGES - BRUSHED STAINLESS STEEL

FIXINGS - ALL GRADE 8.8 ZINC PLATED

FINISH:-

FRAMEWORK: - NON-VISIBLE STEELWORK TO BE HOT DIP GALVANISED TO BSEN ISO 1461 AFTER FABRICATION (UN-PAINTED)

PANELS: - VISIBLE STEELWORK TO BE PPC FINISH, STANDARD RAL COLOUR, COLOUR TBC

PAD ATTENUATOR: - PPC FINISH, STANDARD RAL COLOUR, COLOUR TBC

LOUVRE PANELS: - PPC FINISH, STANDARD RAL COLOUR, COLOUR TBC

TRIMS: - PPC FINISH, STANDARD RAL COLOUR, COLOUR TBC

QUANTITY:- - 1 ENCLOSURE REQUIRED

APPROXIMATE WEIGHT:- - 3050KGS

01	ISSUED FOR COMMENT	D.M	24/07/19
REV:	DESCRIPTION:	BY:	DATE:

AMENDMENTS:

Wakefield Acoustics Ltd
FLUSH MILLS
WESTGATE
HECKMONDWIKE
WEST YORKSHIRE
WF16 0EN
TEL: +44 (0) 1924 418940 - FAX: +44 (0) 1924 418950
web site: www.wakefieldacoustics.co.uk
e-mail: noise@wakefieldacoustics.co.uk

INDUSTRIAL NOISE CONTROL TECHNOLOGY

TITLE: GENERAL ARRANGEMENT OF ACOUSTIC ENCLOSURE (COMMERCIAL 2)
REF: PRIMA, OLD DAIRY LONDON

DRAWING No: C28336-101-02
REV: 01

DRAWN: D.M
DATE: 24/07/19

CHECKED: A.O
DATE: 24/07/19

SCALE: NTS
SHT-No: 1 of 1

SIZE: A1

THIS DRAWING IS THE COPYRIGHT OF WAKEFIELD ACOUSTICS LIMITED. IT MUST NOT BE COPIED OR DISCLOSED TO A THIRD PARTY WITHOUT WRITTEN CONSENT AND IS SUBJECT TO RECALL AT ANY TIME.
© 2018