

Appendix C

Piled Wall Design Calculations



SECANT PILED RETAINING WALL DESIGN
FOR TEMPORARY AND PERMANENT CONDITIONS
& BEARING PILES
AT
24-26 REDINGTON GARDENS
HAMPSTEAD
LONDON, NW11

Revision	C1	Amended Pile Layout, Surcharges, Pile Loads	3 rd December 2018
Initial Issue	C0	Design Calculations for Comment / Approval	4 th October 2018
Stage	Revision	Comments	Date



CONTENTS	PAGE
1.0 INTRODUCTION	3
2.0 INFORMATION PROVIDED.....	5
2.1 General and Structural Arrangements for the Proposed Development	5
2.2 Ground Conditions	6
3.0 DESIGN PARAMETERS	8
3.1 Geotechnical	8
3.2 Construction Sequence.....	8
3.3 Structural Design Parameters.....	8
4.0 DESIGN METHODOLOGY	12
4.1 Geotechnical Analysis for Secant Bored Pile Retaining Wall	12
4.2 Individual Pile Section Structural Analysis	14
4.3 Retaining Wall and Bearing Pile Axial Load Carrying Capacity	20
4.4 Tension Capacity Check (Bearing Piles)	22
4.5 Bearing Pile Lateral Capacity.....	23
5.0 SUMMARY OF RESULTS AND GENERAL COMMENTS	26
APPENDIX A.....	
APPENDIX B.....	
APPENDIX C.....	
APPENDIX D.....	
APPENDIX E.....	



1.0 INTRODUCTION

As part of the redevelopment of a site at 24-26 Redington Gardens, Hampstead, London, NW11, it is proposed to construct three number three storey semi-detached houses including a single level basement beneath each house. The existing buildings on the site have already been demolished.

The site can be located by National Grid Reference TQ 27579 85955 and lies off the North side of Redington Gardens, which provides the site access. The Western boundary adjoins the house and gardens of number 7 Redington Gardens, while the Eastern boundary adjoins the house and gardens of Conrad Court, number 27 Redington Gardens. The Northern boundary adjoins the rear gardens of houses on Templewood Avenue.

To allow construction of the proposed basements secant piled walls are proposed around all sides of the basements.

The plan positions of the new basements and the proposed retaining walls are shown on the site plan, given on Figure 1 – see page 4. This also shows the sections taken for the design.

These calculations cover the design of the temporary / permanent piled retaining walls, axial loads on the retaining wall piles and a number of bearing piles within the basement. This revision covers the issue of revised drawings with a new pile layout, revised surcharge loadings and revised retaining wall axial and bearing pile loads.

The calculations have been carried out by Piledesigns Limited on behalf of MY Construction.

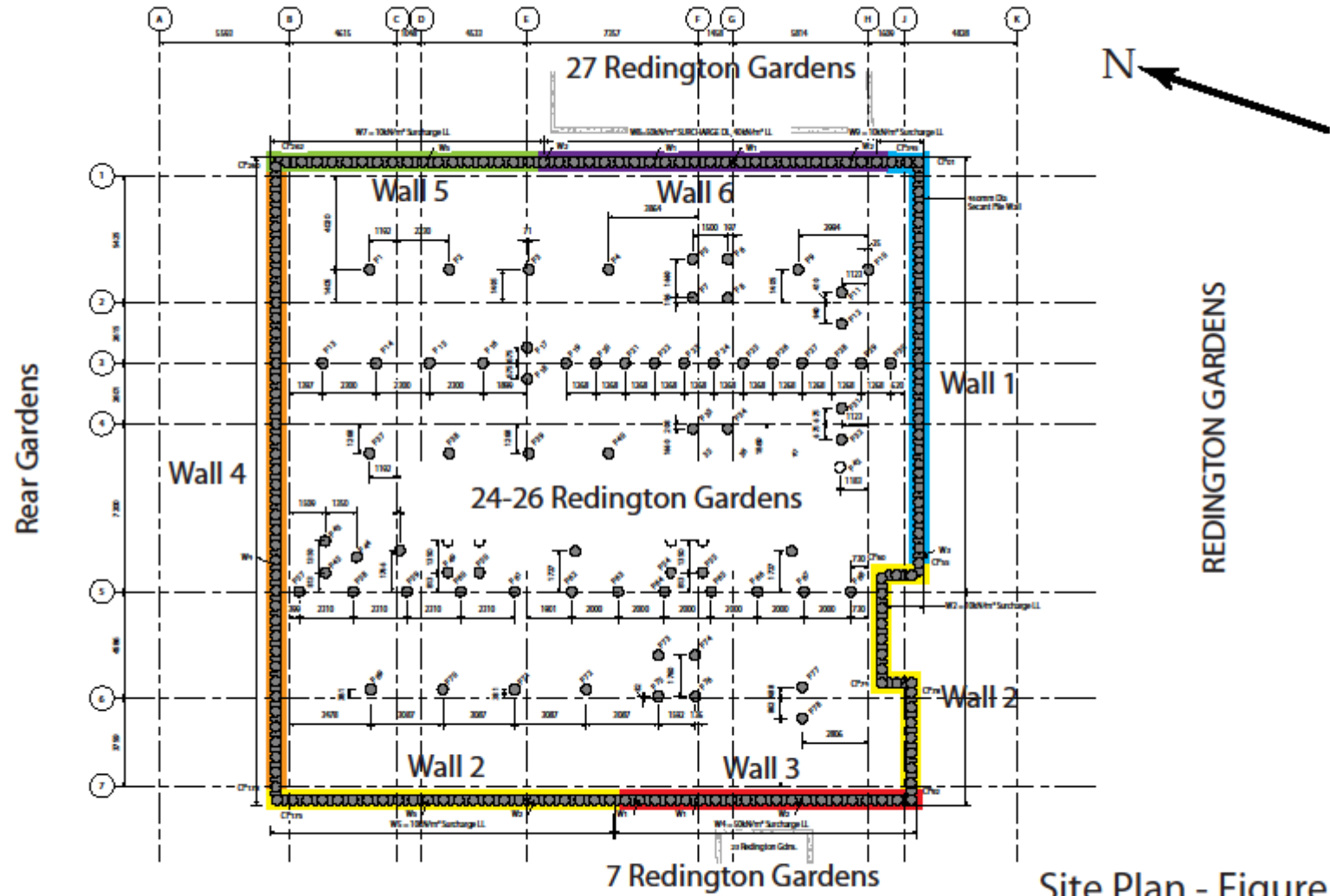

Site Plan - Figure 1



2.0 INFORMATION PROVIDED

2.1 General and Structural Arrangements for the Proposed Development

Details of the proposed retaining walls have been taken from the relevant drawings provided, which are from Cranston Consulting, Structural & Civil Engineers for the project under their project no: 180709. Further clarification has been provided following verbal and email communication with the Engineer & the Piling / Main Contractor.

The main retaining wall and bearing pile drawings can be summarised as follows:

GA-01 revision P2: Proposed Pile Layout
SE 20: Proposed Temporary Works Sections
SE 21: Proposed Temporary Works Sections

Six wall sections have been identified for this analysis, labelled Walls 1-6. The sections have been indicated on Figure 1, and has been chosen to represent the general soil and structural criteria for the site.

The piling platform level has been given as 49.75mAD.

Wall 1 covers the piles on Grid Line J between Grid Lines 1 & 5 along with a short return on Grid Line 1, for which the Basement structural slab level is given as 44.005mAD. With a 300mm slab and 50mm of blinding concrete the SLS dig level has been taken as 43.655mAD. A further allowance of 470mm for possible (unplanned) over-dig has been taken for the ULS case. A general surcharge of 10kN/m² has been taken behind the wall for the temporary and permanent conditions.

Wall 2 covers the remainder of the piles on Grid Line J and the piles on Grid Line 7 between Grid Lines B & half way between E & F, for which the Basement structural slab level is given as 44.208mAD. With a 300mm slab and 50mm of blinding concrete the SLS dig level has been taken as 43.858mAD. A further allowance of 440mm for possible (unplanned) over-dig has been taken for the ULS case. A general surcharge of 13kN/m² has been taken behind the wall for the temporary and permanent conditions.

Wall 3 covers the piles on Grid Line 7 adjacent to number 23 Redington Gardens, for which the Basement structural slab level is given as 44.208mAD. With a 300mm slab and 50mm of blinding concrete the SLS dig level has been taken as 43.858mAD. A further allowance of 440mm for possible (unplanned) over-dig has been taken for the ULS case. A general surcharge of 13kN/m² has been taken behind the wall for the temporary and permanent conditions. In addition surcharge has been allowed for the adjacent building foundations, taken as 90kN/m², over a width of 500mm, at a level of 49.1mAD and at a distance of 3.25m from the retaining wall.

Wall 4 covers the piles on Grid Line B, for which the lowest Basement structural slab level is given as 44.005mAD. With a 300mm slab and 50mm of blinding concrete the SLS dig level has been taken as 43.655m AD. A further allowance of 460mm for possible (unplanned) over-dig has been taken for the ULS case. A general surcharge of 10kN/m² has been taken behind the wall for the temporary and permanent conditions.

Wall 5 covers the piles on Grid Line 1 between Grid Lines B & E, for which the Basement structural slab level is given as 44.005mAD. With a 300mm slab and 50mm of blinding concrete the SLS dig level has been taken as 43.655m AD. A further allowance of 450mm for possible (unplanned) over-dig has been taken for the ULS case. A general surcharge of 10kN/m² has been taken behind the wall for the temporary and permanent conditions.



Wall 6 covers the piles on Grid Line 1 adjacent to number 27 Redington Gardens, for which the Basement structural slab level is given as 44.005mAD. With a 300mm slab and 50mm of blinding concrete the SLS dig level has been taken as 43.655mAD. A further allowance of 480mm for possible (unplanned) over-dig has been taken for the ULS case. A general surcharge of 11.5kN/m² has been taken behind the wall for the temporary and permanent conditions. In addition surcharge has been allowed for the adjacent building foundations, taken as 50kN/m² (dead) & 40kN/m² (live), over a width of 500mm, at a level of 49.5mAD and at a distance of 1.1m from the retaining wall.

All surcharge loads have been given as live load unless noted otherwise.

2.2 Ground Conditions

Ground conditions have been taken from a Site Investigation Report carried out by Geotechnical & Environmental Associates; report reference: J15031, dated May 2015. The investigation contains the records of one Cable Percussion and two Window Sampler boreholes taken to a maximum depth of 20.0m.

The boreholes showed the ground conditions to comprise Made Ground over Alluvium over Claygate Beds over London Clay. The Made Ground generally comprised Tarmac/concrete, paving or topsoil over sandy gravelly silty clay and silty sand, while the Alluvium was described as peat, clayey sand, very soft to soft sandy silty clay, silt and sand & gravel. The Claygate Beds were recorded as soft to firm silty clay with gravel and some sand layers, while the London Clay was noted as firm brown weathered silty clay with occasional sand partings over stiff grey fissured silty clay.

A summary of the borehole results is presented in Table 1.

Table 1: Borehole Results

Borehole No	Location	Ground Level (mAD)	Level of Alluvium / Claygate / London Clay (mAD)	Ground water levels in boreholes (mAD)
BH1	-	50.0	48.8 / - / 45.2	-
BH2	-	50.0	48.5 / 46.6 / 44.5	47.6
BH3	-	50.5	49.0 / 47.5 / 45.5	47.5

A plot of SPT 'N' values and triaxial strength test results is presented in Figure 2 – see sheet 7.

For the purpose of the retaining wall design the Made Ground (incorporating the softer Alluvium) has been taken to a level of 47.5mAD, the Claygate Beds (incorporating the stiffer Alluvium shown in BH2) to a level of 45.0mAD, with the London Clay taken to depth.

A design line in the London Clay has been taken as a shear strength of 50kN/m² at a level of 45.0mAD and increasing at a rate of 5kN/m² per metre depth to a level of 35.0mAD then increasing at a rate of 10kN/m² per metre depth.

Groundwater was recorded in the boreholes during drilling at a highest level of 47.6mAD and during subsequent monitoring at a highest level of 49.36mAD.

The assumed soil profile and design parameters should be checked during initial piling operations and any variations notified to the designer.

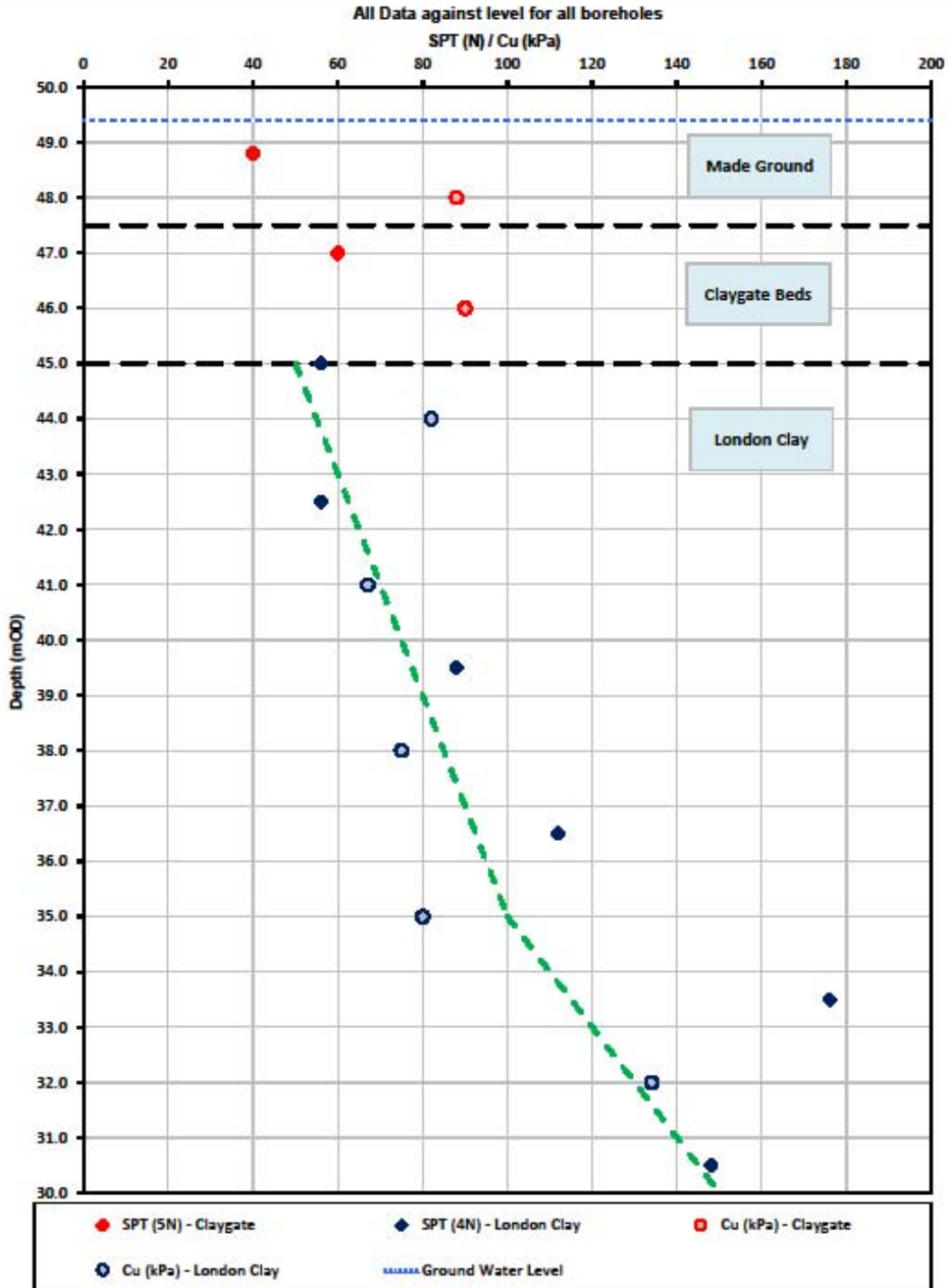



3.0 DESIGN PARAMETERS

3.1 Geotechnical

The pile design calculations have been based on the information provided. The soil parameters employed have generally been taken from the soils information provided and checked against published data and other ground investigation reports in the area. The analysis has considered drained conditions for the Made Ground and Claygate Beds and undrained conditions for the London Clay when applied to the temporary condition. For the permanent condition all soil types have been changed to the drained condition where applicable.

The sections shown on Figures 3 and 4 on sheets 10 and 11 show the typical soil profile used in the analysis and the soil parameters for the drained and undrained conditions.

Groundwater for the temporary condition has been taken at a level of 49.4mAD with dewatering carried out as required to below the relevant formation levels. For the permanent condition groundwater has been taken at the underside of the basement on the passive side and 49.4mAD on the active side.

3.2 Construction Sequence

Walls 1 to 6

- Carry out piling from the assumed piling platform level (49.75mAD)
- Excavate for and construct the Lower Ground Floor RC slab (after adequate curing of the piles)
- After adequate curing of the Lower Ground Floor slab excavate to Basement slab formation level utilising a “Top Down” construction sequence
- Construct Basement RC slab
- Apply long term parameters to piles and soils
- Apply high water check

3.3 Structural Design Parameters

The male secant retaining wall piles will be constructed using Auger Bored piling techniques with a minimum C30/37 designed concrete pump mix and ‘B’ (500N/mm²) grade main reinforcement bars with helical shear links. A minimum of 75mm cover to the main reinforcement will be provided by propriety spacers.

The female secant retaining wall piles should be typically installed one metre into a low permeability stratum (i.e. London Clay), therefore a suitable toe level would be approximately 44.0mAD.

The main structural design parameters used in the retaining wall analysis have been summarized in Table 2, for 450mm diameter piles at approximately 650mm centres.



Table 2 – Main Structural Design Parameters

Material	Short Term Parameters	Long Term Parameters
Concrete 450mm diameter @ 650mm centres	E = $1.96 \times 10^{+7}$ kN/m ² I = 3.09×10^{-3} m ⁴ /m run E.I = 60696 kN.m ² / m run	E = $1.40 \times 10^{+7}$ kN/m ² I = 3.09×10^{-3} m ⁴ /m run E.I = 43354.5 kN.m ² / m run
Steel	E = $2.05 \times 10^{+8}$ kN/m ²	E = $2.05 \times 10^{+8}$ kN/m ²

Notes:

Short term EI = 70% of the initial value.

Long term EI = 50% of the initial value.

TYPICAL SECTION FOR SLS CONDITIONS - Figure 3

General surcharge of 10kN/m² allowed plus adjoining building surcharges

PASSIVE

ACTIVE

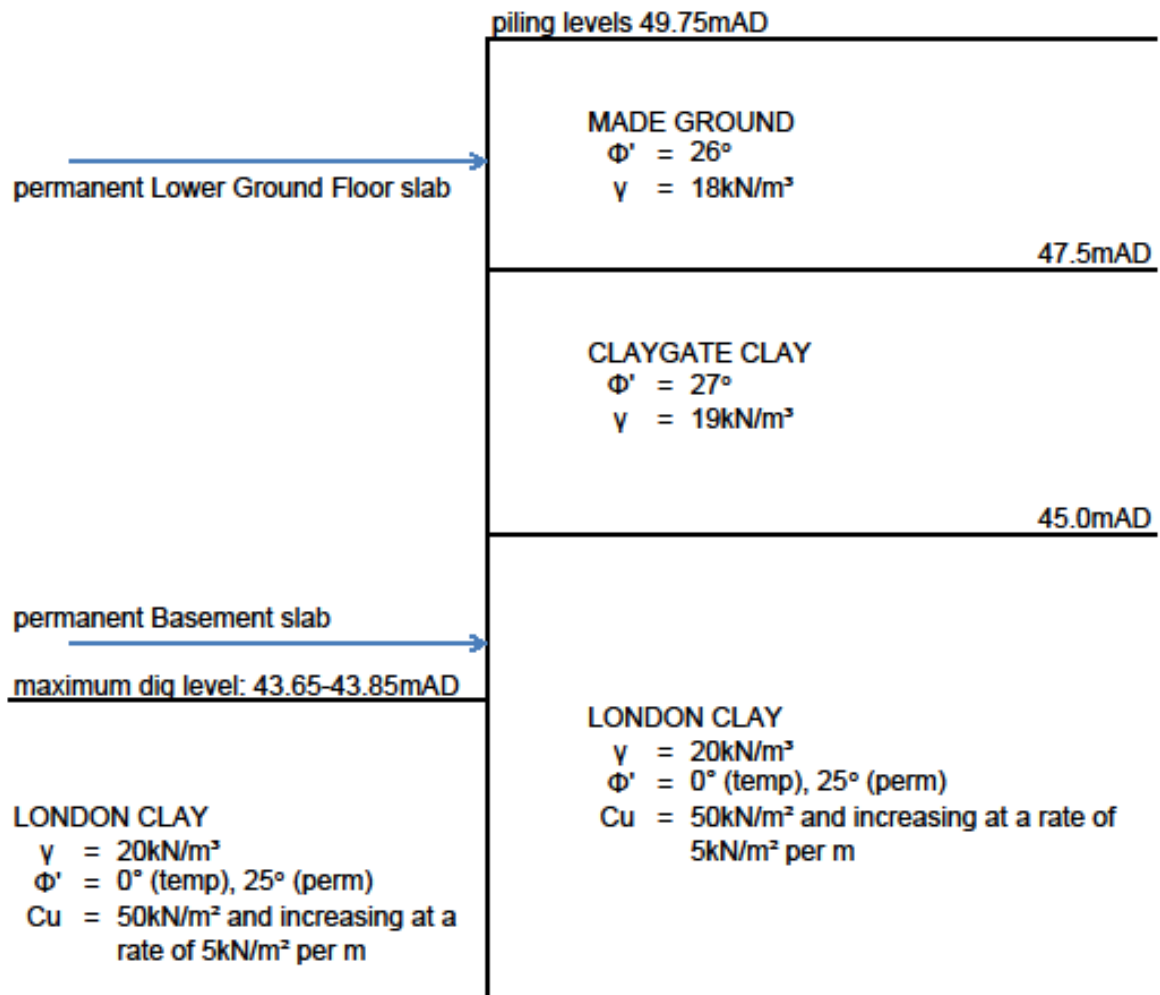

A typical initial water level of 49.4mAD has been taken on the passive and active sides for the temporary condition with dewatering to below formation level as required. For the permanent condition water has been taken at the underside of the Basement slab on the passive side and to 49.4mAD on the active side.

TYPICAL SECTION FOR ULS CONDITIONS - Figure 4

General surcharge of 10kN/m² allowed plus adjoining building surcharges

PASSIVE

ACTIVE

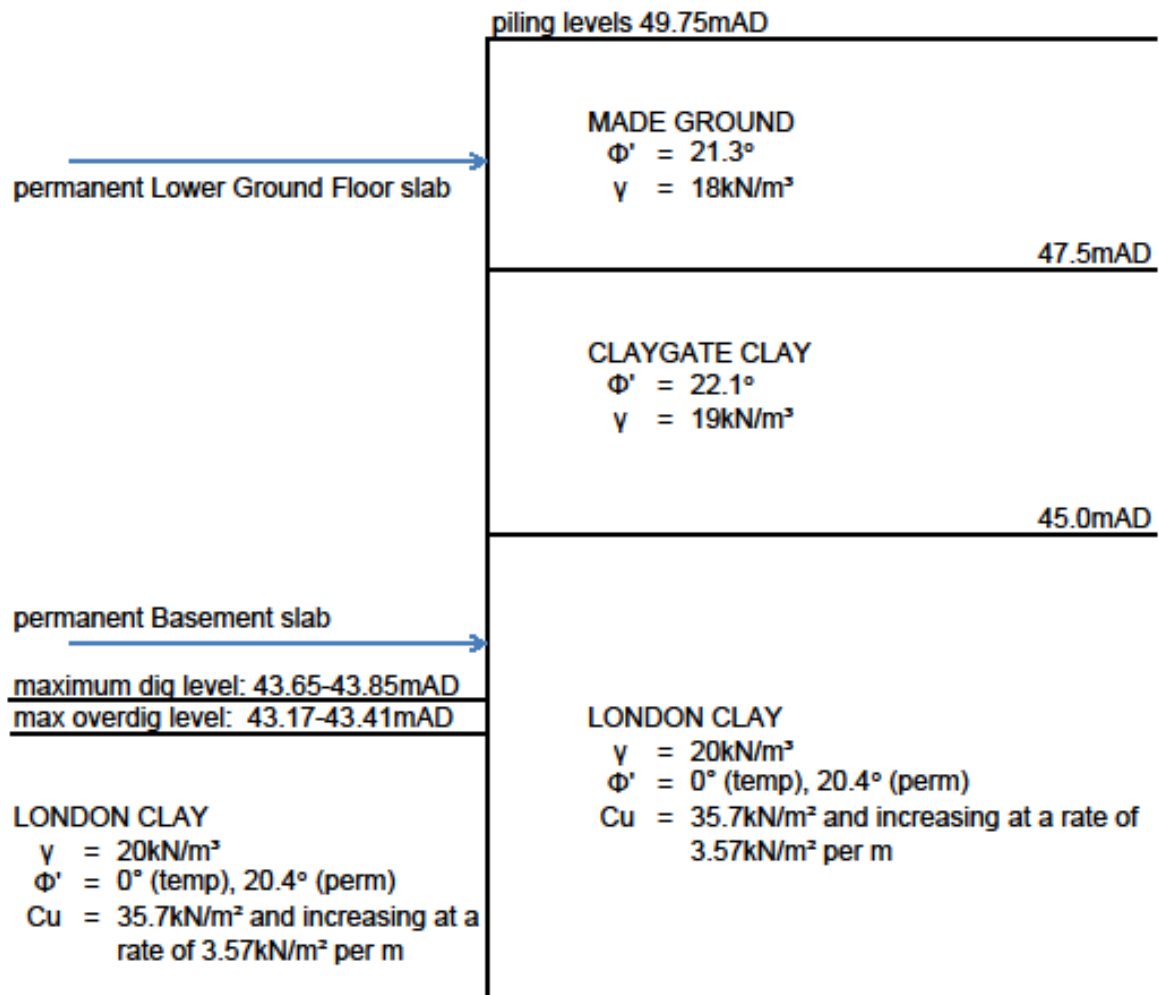

A typical initial water level of 49.4mAD has been taken on the passive and active sides for the temporary condition with dewatering to below formation level as required. For the permanent condition water has been taken at the underside of the Basement slab on the passive side and to 49.4mAD on the active side.



3.4 Retaining Wall and Propping Geometry

Walls 1 to 6 will act as an propped cantilevers (utilising a “Top Down” construction sequence) in the temporary condition and be propped by the Basement and Lower Ground Floor slabs in the permanent condition.

Table 3 presents the structural and geometrical properties of the propping that has been used in the design of the retaining wall.

Table 3: Assumed details of horizontal propping

Wall no / Prop no (Perm/Temp)	Prop Elevation (mAD)	Prop Spacing (m)	Prop Sectional area (m ²)	Prop Young's modulus (kN/m ²)	Prop free length (m)
1 / 1 (Perm) – Lower Ground Floor slab	48.35	1.0	0.4	1.40 x 10 ⁺⁷	5.00
2&3 / 1 (Perm) – Lower Ground Floor slab	48.20	1.0	0.3	1.40 x 10 ⁺⁷	5.00
4 / 1 (Perm) – Lower Ground Floor slab	48.21	1.0	0.4	1.40 x 10 ⁺⁷	5.00
5 / 1 (Perm) – Lower Ground Floor slab	48.10	1.0	0.4	1.40 x 10 ⁺⁷	5.00
6 / 1 (Perm) – Lower Ground Floor slab	48.40	1.0	0.3	1.40 x 10 ⁺⁷	5.00
1, 4-6 / 2 (Perm) – Basement slab	43.85	1.0	0.3	1.40 x 10 ⁺⁷	5.00
2-3 / 2 (Perm) – Basement slab	44.05	1.0	0.3	1.40 x 10 ⁺⁷	5.00

Prop levels taken as the approximate midpoint of the structural slabs.

Should the construction sequence or propping system be changed from that assumed then the retaining wall design will require to be reassessed which could result in changes to the pile length and / or reinforcement.

4.0 DESIGN METHODOLOGY

4.1 Geotechnical Analysis for Secant Bored Pile Retaining Wall

The retaining wall analysis has been carried out using the computer program ‘WALLAP’ Version 6.06 developed by Geosolve.

The design has been carried out using the ‘Strength Factor’ approach with partial factors in accordance with BS EN 1997-1: 2004 Eurocode 7 and to the approach as prescribed in the UK National Annex of BS EN 1997–1. Using this approach three runs for each section may be carried out and these are typically referenced as:-

SLS	service limit state
ULS-comb 1	ultimate limit state – structural (STR)
ULS-comb 2	ultimate limit state – geotechnical (GEO)

With respect to the above the wall design is checked in its ultimate state by applying partial factors and carrying out two separate checks (combinations), as shown in Table 4 which have been taken from Tables NA.A1. (B) and (C) of the UK National Annex to BA EN 1990+A1;

2005 for the actions and Table A. NA.4 of the National annex to BS EN 1997-1: 2004 for the soil parameters.

Both represent ultimate conditions with combination 1 the structural ultimate case (ULS-STR), and combination 2 the geotechnical ultimate case (ULS-GEO). Combination 1 applies partial factors to actions (A) - (temporary/permanent actions, G_k , and variable actions, Q_k) while soil parameters (M1) and pile resistances (R1) are kept un-factored ($R1$ & $M1 = 1.0$). Combination 2 applies partial factors to the soil parameters (M2) and partial factors of smaller magnitude to the variable actions (A). For both these cases the design is mainly to verify that the proposed embedment length i.e. reinforced pile length / toe level, provides a nominal factor of safety against failure. Bending and shear forces are un-factored in any subsequent structural calculations for ULS-comb 2, but factored by 1.35 for ULS-comb 1. An allowance for overdig within both ultimate cases is included and taken as up to a maximum of 10% of the retained height (or 0.5m whichever is the lesser).

Table 4 Partial factors adopted for design (Retaining Wall Earth Pressures).

	Notation	Partial Factor		
		SLS	DA1 Comb. 1	DA1 Comb. 2
ACTIONS: (A)				
Permanent Action (Unfavourable)	G_k	1.0	1.35 (A1)	1.0 (A2)
Variable Action (Unfavourable)	Q_k	1.0	1.50 (A1)	1.3 (A2)
SOIL FACTORS: (M)				
Effective angle of shearing resistance	$\tan \phi'$	1.0	1.0 (M1)	1.25 (M2)
Effective cohesion	C'	1.0	1.0 (M1)	1.25 (M2)
Undrained shear strength	C_u	1.0	1.0 (M1)	1.40 (M2)
RESISTANCES: (R)				
Earth resistance	γ_{Re}	1.0	1.0 (R1)	1.0 (R1)

Notes – factors given above apply to Actions which refer to unfavourable conditions

- Combination 1 (ULS-STR): A1 + M1 + R1.
- Combination 2 (ULS-GEO): A2 + M2 + R1.

A further analysis is included which represents SLS conditions and usually carried out to determine wall deflections. The analysis assumes moderately conservative soil parameters, with a partial factor (M2) taken as 1.0 and no allowance for overdig. This calculation also provides bending moments and shear forces which are factored up by 1.35 in any subsequent structural calculations. The results from this analysis are provided per metre run and therefore amended to the particular pile diameter and spacing.

The input and output data from the WALLAP analyses are presented in Appendix A. The Ultimate Limit State (ULS) conditions employ factored soil parameters as required for the (ULS-GEO), DA1 Combination 2 conditions.

Calculated wall displacements and corresponding program outputs may be considered to be an upper bound estimate of long-term movements, due to the following factors:

- Geotechnical parameters, pile stiffness and surcharges are considered to be reasonably conservative values. A more accurate assessment of wall displacements would require the input of 'actual' parameters to be obtained from more sophisticated laboratory testing.
- The computer program does not consider the beneficial effects of structural elements such as a capping beam.



- (c) The computer program is a two-dimensional analysis program and does not consider the beneficial effects of geometrical features such as internal or external wall corners which increase its overall stiffness.
- (d) The computer program uses a Winkler spring analysis to determine the wall displacements, in which springs are used to represent a continuum and there is no transfer of shear stresses between springs. In general, the application of this concept leads to an overestimation of structural deformations; hence the resulting displacements may be over-predicted.

The results of the WALLAP analysis are given in Appendix A. These are summarised in Tables 5, 6 and 7 and given below. Table 5 provides the results of the stability analysis from WALLAP and calculated deflections. It includes varying sets of bending moments and shear forces. Reinforcement calculations are based on the worst case bending moments and shear values determined from the un-factored ULS-comb 2 and factored SLS and ULS-comb 1 results. Table 6 details the temporary and permanent prop forces and Table 7 shows the details of the sections with the proposed pile length.

The estimated actual deflections should be in the region of 50 to 70% of the calculated figures and a typical figure for actual deflection may be taken as 60%.

4.2 Individual Pile Section Structural Analysis

Reinforcement requirements have been analysed for the shear forces and bending moments indicated within the WALLAP outputs (Appendix A) and summarized in the wall schedule, (Table 7). Using the Oasys ADCOL software, all bending moments and shear force calculations have been carried out in accordance with the requirements of BS EN 1992, Eurocode No. 2 'Design of Concrete Structures'.

The results of the ADCOL analyses are given in Appendix B. For all cases the concrete grade has been taken as a minimum C30/37 and a worst case axial load of 100kN tension.



TABLE 5 - Results of Retaining Wall Analysis (Wall 1)

Sections Ref	Case	Pile diameter	Pile spacing (approx)	Calculated deflection	Estimated deflection	Bending Moments			Shear		Ultimate Design Values per pile at spacing given		
						Maximum	Factor	Ultimate	Maximum	Factor	Ultimate	Moment	Shear
						kN.m/m		kN.m/m	kN/m		kN/m	kN.m	kN
SLS	T/P	450	650	11	7	94.0	1.35	126.9	133.0	1.35	179.6	82.5	116.7
ULS1	T/P	450	650			119.0	1.35	160.7	145.0	1.35	195.8	104.4	127.2
ULS2	T/P	450	650			148.0	1.00	148.0	199.6	1.00	199.6	98.2	129.7
										Max	450	104.4	129.7

TABLE 5 - Results of Retaining Wall Analysis (Wall 2)

Sections Ref	Case	Pile diameter	Pile spacing (approx)	Calculated deflection	Estimated deflection	Bending Moments			Shear		Ultimate Design Values per pile at spacing given		
						Maximum	Factor	Ultimate	Maximum	Factor	Ultimate	Moment	Shear
						kN.m/m		kN.m/m	kN/m		kN/m	kN.m	kN
SLS	T/P	450	650	11	7	82.0	1.35	110.7	125.0	1.35	168.8	72.0	109.7
ULS1	T/P	450	650			101.0	1.35	136.4	125.0	1.35	168.8	88.6	109.7
ULS2	T/P	450	650			151.6	1.00	151.6	181.4	1.00	181.4	98.5	117.9
										Max	450	98.5	117.9



TABLE 5 - Results of Retaining Wall Analysis (Wall 3)

Sections Ref	Case	Pile diameter	Pile spacing (approx)	Calculated deflection	Estimated deflection	Bending Moments			Shear		Ultimate Design Values per pile at spacing given		
						Maximum	Factor	Ultimate	Maximum	Factor	Ultimate	Moment	Shear
						kN.m/m		kN.m/m	kN/m		kN/m	kN.m	kN
Temp / Perm	mm	mm	mm	mm									
SLS	T/P	450	650	11	7	82.0	1.35	110.7	125.0	1.35	168.8	72.0	109.7
ULS1	T/P	450	650			102.0	1.35	137.7	125.0	1.35	168.8	89.5	109.7
ULS2	T/P	450	650			129.4	1.00	129.4	181.0	1.00	181.0	84.1	117.7
										Max	450	89.5	117.7

TABLE 5 - Results of Retaining Wall Analysis (Wall 4)

Sections Ref	Case	Pile diameter	Pile spacing (approx)	Calculated deflection	Estimated deflection	Bending Moments			Shear		Ultimate Design Values per pile at spacing given		
						Maximum	Factor	Ultimate	Maximum	Factor	Ultimate	Moment	Shear
						kN.m/m		kN.m/m	kN/m		kN/m	kN.m	kN
Temp / Perm	mm	mm	mm	mm									
SLS	T/P	450	650	6	4	75.0	1.35	101.3	95.0	1.35	128.3	65.8	83.4
ULS1	T/P	450	650			88.0	1.35	118.8	96.0	1.35	129.6	77.2	84.2
ULS2	T/P	450	650			97.1	1.00	97.1	131.4	1.00	131.4	63.1	85.4
										Max	450	77.2	85.4



TABLE 5 - Results of Retaining Wall Analysis (Wall 5)

Sections Ref	Case	Pile diameter mm	Pile spacing (approx) mm	Calculated deflection mm	Estimated deflection mm	Bending Moments			Shear		Ultimate Design Values per pile at spacing given		
						Maximum	Factor	Ultimate	Maximum	Factor	Ultimate	Moment	Shear
						kN.m/m		kN.m/m	kN/m		kN/m	kN.m	kN
SLS	T/P	450	650	13	8	80.0	1.35	108.0	132.0	1.35	178.2	70.2	115.8
ULS1	T/P	450	650			102.0	1.35	137.7	138.0	1.35	186.3	89.5	121.1
ULS2	T/P	450	650			170.3	1.00	170.3	190.3	1.00	190.3	110.7	123.7
										Max	450	110.7	123.7

TABLE 5 - Results of Retaining Wall Analysis (Wall 6)

Sections Ref	Case	Pile diameter mm	Pile spacing (approx) mm	Calculated deflection mm	Estimated deflection mm	Bending Moments			Shear		Ultimate Design Values per pile at spacing given		
						Maximum	Factor	Ultimate	Maximum	Factor	Ultimate	Moment	Shear
						kN.m/m		kN.m/m	kN/m		kN/m	kN.m	kN
SLS	T/P	450	650	11	7	109.0	1.35	147.2	149.0	1.35	201.2	95.6	130.7
ULS1	T/P	450	650			125.0	1.35	168.8	150.0	1.35	202.5	109.7	131.6
ULS2	T/P	450	650			189.9	1.00	189.9	215.4	1.00	215.4	123.4	140.0
										Max	450	123.4	140.0

TABLE 6 - Details of Prop Forces

Wall Ref	Strut Ref	Type	Level	SLS Results Prop Force unfactored kN/m run	ULS Results Prop Force unfactored	
			mAD		ULS1	ULS2
					kN/m run	
1	1	Basement slab	48.35	111.0	126.0	138.6
	2	LGF slab	43.85	229.0	241.0	351.0
2	1	Basement slab	48.20	116.0	128.0	142.6
	2	LGF slab	44.05	203.0	207.0	322.1
3	1	Basement slab	48.20	116.0	128.0	142.0
	2	LGF slab	44.05	204.0	208.0	320.9
4	1	Basement slab	48.21	47.0	52.0	56.8
	2	LGF slab	43.85	148.0	154.0	232.1
5	1	Basement slab	48.10	121.0	135.0	149.1
	2	LGF slab	43.85	219.0	233.0	341.4
6	1	Basement slab	48.40	119.0	127.0	142.5
	2	LGF slab	43.85	242.0	248.0	377.8



TABLE 7 - Details of Retaining Wall Piles

Wall Section	Pile diameter mm	Pile spacing mm	Assumed Piling Level mAD	RW Pile Length m	RW Pile Toe Level mAD	No	Reinforcement				
							Main Bars size mm	Main Bars length m	Helical size @ spacing mm @ mm		
1	450	650	49.750	9.0	40.750	5	* B25	* 9.0	B10 @ 200		
2	450	650	49.750	9.0	40.750	6	* B20	* 9.0	B10 @ 200		
3	450	650	49.750	9.0	40.750	6	* B20	* 9.0	B10 @ 200		
4	450	650	49.750	9.0	40.750	5	* B20	* 9.0	B10 @ 200		
5	450	650	49.750	9.0	40.750	5	* B25	* 9.0	B10 @ 200		
6	450	650	49.750	9.0	40.750	6	* B25	* 9.0	B10 @ 200		

Pile length & steel given is for retaining function only - pile length & steel to be increased to cater for axial loads - see Wall Pile schedule



4.3 Retaining Wall and Bearing Pile Axial Load Carrying Capacity

The retaining wall piles will be required to carry axial compression loads of 160-175kN (permanent) and 40kN (variable) and axial tension loads of 100kN (variable) at a discounted level of 43.6mAD.

For piles in a retaining wall a reduction factor is usually applicable due to the close centres of the piles within the wall. This factor is applied to the shaft resistance only. For the 450mm diameter piles at a spacing of 650mm, take the surface area per metre depth as 1.3m^2 , ie the wall is considered as a straight sided section, ($2 * 0.65\text{m}$ pile spacing). Relating this value to the surface area of an isolated 450mm diameter pile ($1.414\text{m}^2/\text{m}$), the reduction factor for shaft friction is determined to be 0.92. No reduction factor is applicable to the end bearing since the base surface area per metre per pile in the wall (0.29m^2) is larger than the base area of a single pile (0.159m^2).

A number of the wall piles have additional point loads applied. These have been spread over an appropriate number of adjacent piles (up to 4 maximum).

A number of bearing piles are also required within the basement with axial compression loads of 200-600kN (permanent), 50-185kN (variable), ± 25 -60kN wind (variable) and axial tension loads of 250-875kN (permanent) at discounted levels of 42.0-43.7mAD. Some bearing piles have horizontal loads of 25-60kN applied at cut-off level.

Axial Design

The design has been carried out in general in accordance with Eurocode (BS EN 1997-1:2004) with reference made to the UK National Annex. This is an ultimate limit state design approach with partial factors applied to actions (A), materials (M) and resistances (R). Pile lengths have been determined to satisfy a structural check (STR), with partial factors only applied to actions, and a geotechnical check (GEO), with partial factors applied to both actions and resistances. These are in accordance with the Eurocode Design Approach 1 and referred to as combinations DA1-1 and DA1-2 respectively.

An explanation of the appropriate partial factors as usually derived for these combinations is indicated below.

Design Approach 1 - Combination - 1

Taken as $A1 + M1 + R1$

With partial factors of 1.0 applied to both M1 and R1

For A1 a factor of 1.35 has been applied to the permanent loads and 1.5 applied to the variable loads.

Design Approach 1 - Combination - 2

Taken as $A2 + M1 + R4$

For A2 a factor of 1.0 has been applied to the permanent loads and 1.3 applied to the variable loads.

For M1 all factors have been taken as unity.



Partial factors for R4 relate mainly to testing and also pile type, with factors applied to both shaft adhesion and end bearing for the latter. For this site it is understood that no pile testing is proposed.

Partial factors for GEO limit state from Table A.NA.8 as follows:

1.6 applied to shaft resistance and 2.0 to the base resistance with a model factor of 1.4 applied to both. The above factors apply without any explicit verification testing.

Vertical Design

Assumed soil profile

49.75mAD	to	Discounted Level	DISCOUNTED SOIL
Discounted Level	to	--- mAD	LONDON CLAY

Groundwater taken as 49.4mAD.

Design A : Discounted level 43.7mAD bearing piles (COL 43.007-43.505)

Design B : Discounted level 43.0mAD bearing piles (COL 43.805-44.132)

Design C : Discounted level 43.6mAD wall piles

Shaft Adhesion

In DISCOUNTED SOIL Density taken as 18kN/m³
Discounted for positive skin friction

In LONDON CLAY Density taken as 20kN/m³
with shear strength as 50kN/m² at a level of 45.0mAD and increasing
at a rate of 5.0kN/m² per metre to a level of 35.0mAD and then
increasing at a rate of 10kN/m² per metre
Use 0.5 shear strength

End Bearing

In LONDON CLAY For unit end bearing use 9 * shear strength with shear strength
values as given above.

Factor of Safety

Shaft resistance, FOS	1.6
End resistance, FOS	2.0

For EC7 approach also with model factor of 1.4 applied to both

The above calculations have been carried out using the OASYS Pile program, version 19.6 which allows the appropriate partial factors to be applied to the soil parameters. The results are given in Appendix C1. Perusal of the appropriate actions shows that design approach



case 2 (DA1-2) dictates and the calculated results for the 450mm diameter wall and bearing piles are shown in the separate wall and bearing pile schedules.

Appendix C1 : Discounted level 43.7mAD bearing piles (COL 43.007-43.505)
Appendix C2 : Discounted level 43.0mAD bearing piles (COL 43.805-44.132)
Appendix C3 : Discounted level 43.6mAD wall piles

Concrete C30/37 minimum

See separate Bearing Pile and Wall Schedules for full details of pile loads, pile lengths, reinforcement etc.

4.4 Tension Capacity Check (Bearing Piles)

Tension capacity derived from shaft friction only

Area of reinforcement for tension condition, A_{st} , check

$$\text{use } A_{st} = T_e / 0.87 * F_y$$

where A_{st} = area of reinforcement
 T_e = tension force – taken as 780kN max (DA1-1 minimum action)
0.87 = material factor on reinforcement
 F_y = grade of reinforcement, taken as 500mN/m²

therefore

$$\begin{aligned} A_{st} &= 780\text{kN} * 1000 / 0.87 * 500 \\ &= 1794\text{mm}^2 \end{aligned}$$

Reinforcement

For up to 780kN tension – use a cage of 6 number B20mm bars with – $A_{st} = 2199\text{mm}^2$

Similarly

For up to 525kN tension – use a cage of 6 number B16mm bars with – $A_{st} = 1206\text{mm}^2$

For up to 340kN tension – use a cage of 4 number B16mm bars with – $A_{st} = 804\text{mm}^2$



4.5 Bearing Pile Lateral Capacity

The bearing piles are required to carry horizontal loads of 25-60kN (variable).

The design has been carried out in general in accordance with Eurocode (BS EN 1997-1:2004) with reference made to the UK National Annex. This is an ultimate limit state design approach with partial factors applied to actions (A), materials (M) and resistances (R). Pile lengths have been determined to satisfy a structural check (STR), with partial factors only applied to actions, and a geotechnical check (GEO), with partial factors applied to both actions and resistances. These are in accordance with the Eurocode Design Approach 1 and referred to as combinations DA-1 and DA-2 respectively.

An explanation of the appropriate partial factors as usually derived for these combinations is indicated below.

Design Approach 1 - Combination - 1

Taken as $A1 + M1 + R1$

For A1 a factor of 1.35 is applied to the permanent loads and 1.5 applied to the sum of the variable loads. Horizontal wind load taken as variable load for this case.

With partial factors of 1.0 applied to both M1 and R1.

Design Approach 1 - Combination - 2

Taken as $A2 + M2 + R1$

For A2 a factor of 1.0 is applied to the permanent loads and 1.3 applied to the sum of the variable loads. Horizontal wind load taken as variable load for this case.

For M2 factors of 1.25 (drained soils) and 1.4 (undrained soils) have been applied to the Materials.

With a partial factor of 1.0 applied to R1.

See pile schedule for details of lateral actions taken on the piles.

Geotechnical Analysis

Analysis of the pile under horizontal load / bending moments has been carried out using the OASYS Limited computer program ALP; version 19.3. The program models the interaction between the pile and the surrounding soil, predicts the pressures, horizontal movements, shear forces and the bending moments induced in the pile.

The pile is modelled as a series of elastic beam elements. The soil is modelled as a series of non-interactive, non-linear springs. The soil deflection has been modelled assuming an elastic plastic behaviour. Two stiffness matrices relating nodal forces to displacements are developed - one represents the pile in bending the other represents the soil.

The assumed soil profile and soil parameters are detailed in the vertical pile calculations.

Coefficients for passive resistance for the various soils have been taken from the data given in the program manual which are based on Tomlinson's coefficients, 1986.



For the piles at this site the pile head is likely to be intermediate between both free and fixed conditions. The method of analysis used has allowed for a nominal rotational stiffness applied at the pile head, taken as 20000kN.m per radian.

The flexural rigidity (EI) of the pile is calculated as follows:-

$$EI = E (\text{concrete}) * I (\text{pile})$$

where E (concrete) is the Young's Modulus of the concrete taken as 20GN/m²

and I (pile) is the Moment of Inertia of the pile

$$EI = \frac{20 * 10^9 * \pi * (0.45)^4}{64 * 10^3}$$

$$= 40258\text{kN/m}^2$$

The lateral loads have been taken as applied at cut-off level, taken as 43.307-43.805mAD. All piles have been taken as restrained with no allowance taken for possible positional tolerances.

Details of the ALP analysis carried out are given in the Table below. For the analysis both lateral actions to DA1-1 (STR) and DA1-2 (GEO) have been considered and the worst case considered for moment condition. The results of the ALP analysis are given in Appendix D1-D4 and show the maximum derived moment and indicate the depth below cut-off level the moment can be considered as sensibly dissipated.

Table of ALP Analyses

Lateral Reference	Lateral Case	Cut-off Level mAD	Design Action kN	Derived Moment kN.m	Depth to dissipate (below cut-off level) m
D1 – A	DA1-1	43.307	90	58.3	6.0
D1 – B	DA1-2		78	57.3	6.0
D2 – A	DA1-1	43.307	75	43.6	5.0
D2 – B	DA1-2		65	42.5	5.0
D3 – A	DA1-1	43.480 & 43.805	38	16.0	5.0
D3 – B	DA1-2		33	14.8	5.0

Structural Analysis

The derived maximum bending moments are checked against the ultimate moments obtained using the OASYS - ADCOL programme for columns to BS 8110. This program calculates the ultimate moment capacity of the pile section with particular concrete and reinforcement and at specified working loads. The analyses have been carried out on the basis of the lateral loads and also for the range of axial loads.

The results are as follows; with each case analysed for specific pile diameter, reinforcement and axial load. For all cases the concrete has been taken as minimum C30/37.

Table of ADCOL Analyses

Appendix (Lateral Case)	Reinforcement (minimum) mm	Lateral reference	Axial Load m	Ultimate moment kN.m
E1-A	6 * B20mm (43.307mAD) (60kN lateral)	DA1-1 (Min)	-328	74.9
E1-B		DA1-1 (Max)	735	155.7
E1-C		DA1-2 (Min)	-316	76.4
E1-D		DA1-2 (Max)	569	150.6
E2-A	5 * B20mm (43.307mAD) (50kN lateral)	DA1-1 (Min)	-325	58.9
E2-B		DA1-1 (Max)	750	145.4
E2-C		DA1-2 (Min)	-313	60.3
E2-D		DA1-2 (Max)	574	139.6
E3-A	5 * B20mm (43.805mAD) (25kN lateral)	DA1-1 (Min)	-525	31.7
E3-B		DA1-1 (Max)	1106	149.1
E3-C		DA1-2 (Min)	-520	32.5
E3-D		DA1-2 (Max)	857	149.1
E4-A	6 * B16mm (43.480 - 43.805mAD) (25kN lateral)	DA1-1 (Min)	-388	28.2
E4-B		DA1-1 (Max)	1106	141.2
E4-C		DA1-2 (Min)	-382	29.3
E4-D		DA1-2 (Max)	857	140.1



From the results of the STR / GEO (DA1-1 and DA1-2) ALP analyses the ADCOL check allow for a safety factor of at least unity on the equivalent derived ultimate moments.

The proposed steel represents a minimum and the number / size of the reinforcement bars may be increased for practical purposes.

Further for all cages the proposed helical has been taken as B8mm helical, using 75mm cover and with a spacing of 200mm centre to centre..

5.0 SUMMARY OF RESULTS AND GENERAL COMMENTS

Summary results of the various wall analyses are presented in Table 5. Temporary and permanent prop forces are presented in Table 6. The pile summary schedule indicating pile lengths and reinforcement is presented in Table 7.

The detailed retaining wall analysis comprising the computer print outs are presented in Appendix A.

Retaining Wall reinforcement calculations comprising the computer printouts from the ADCOL design software and the Helical check are presented in Appendix B.

Axial capacity calculations comprising the computer printouts from the PILE design software are presented in Appendix C.

Bearing Pile lateral capacity calculations comprising the computer printouts from the ALP design software are presented in Appendix D.

Bearing Pile lateral capacity calculations comprising the computer printouts from the ADCOL design software are presented in Appendix E.



APPENDIX A

Ref No	Description
1-ULS1	WALLAP analysis for wall section 1, moments and embedment.
1-ULS2	WALLAP analysis for wall section 1, moments and embedment.
1-SLS	WALLAP analysis for wall section 1, moments and deflection.
2-ULS1	WALLAP analysis for wall section 2, moments and embedment.
2-ULS2	WALLAP analysis for wall section 2, moments and embedment.
2-SLS	WALLAP analysis for wall section 2, moments and deflection.
3-ULS1	WALLAP analysis for wall section 3, moments and embedment.
3-ULS2	WALLAP analysis for wall section 3, moments and embedment.
3-SLS	WALLAP analysis for wall section 3, moments and deflection.
4-ULS1	WALLAP analysis for wall section 4, moments and embedment.
4-ULS2	WALLAP analysis for wall section 4, moments and embedment.
4-SLS	WALLAP analysis for wall section 4, moments and deflection.
5-ULS1	WALLAP analysis for wall section 5, moments and embedment.
5-ULS2	WALLAP analysis for wall section 5, moments and embedment.
5-SLS	WALLAP analysis for wall section 5, moments and deflection.
6-ULS1	WALLAP analysis for wall section 6, moments and embedment.
6-ULS2	WALLAP analysis for wall section 6, moments and embedment.
6-SLS	WALLAP analysis for wall section 6, moments and deflection.



WALLAP

1-ULS1

PILEDESIGNS LTD
 Program: WALLAP Version 6.06 Revision A51.B69.R54
 Licensed from GEOSOLVE
 Data filename/Run ID: Hampstead_Wall_1_450mm_rev_01_ULS1
 Hampstead - 24-26 Redington Gardens
 Wall 1, Secant-ULS1, 450 dia @ 650 - run 01

Sheet No.
 Job No. 21495
 Made by : DBS
 Date: 1-10-2018
 Checked :

Units: kN,m

INPUT DATA

SOIL PROFILE

Stratum no.	Elevation of top of stratum	Soil types	
		Left side	Right side
1	49.75	1 Made Ground dr	1 Made Ground dr
2	47.50	2 Claygate Clay dr	2 Claygate Clay dr
3	45.00	3 London Clay und	3 London Clay und

SOIL PROPERTIES (Unfactored SLS soil strengths)

No. Description (Datum elev.)	Bulk density kN/m3	Young's Modulus Eh, kN/m2 (dEh/dy)	At rest coeff. Ko (dKo/dy)	Consol state. NC/OC (Nu)	Active limit Ka (Kac)	Passive limit Kp (Kpc)	Cohesion kN/m2 (dc/dy)
1 Made Ground dr	18.00	10000	0.530	OC (0.250)	0.337 (0.000)	3.442 (0.000)	
2 Claygate Clay dr	19.00	30000	1.000	NC (0.200)	0.323 (1.330)	3.647 (5.195)	0.0d
3 London Cl.. (45.00)	20.00	40000 (4000)	1.000	OC (0.490)	1.000 (2.476)	1.000 (2.390)	50.00u (5.000)
4 London Cl.. (45.00)	20.00	30800 (3080)	1.000	OC (0.200)	0.351 (1.391)	3.253 (4.831)	0.0d

Additional soil parameters associated with Ka and Kp

No. Description	--- parameters for Ka ---			--- parameters for Kp ---		
	Soil friction angle	Wall adhesion coeff.	Back-fill angle	Soil friction angle	Wall adhesion coeff.	Back-fill angle
1 Made Ground dr	26.00	0.670	0.00	26.00	0.500	0.00
2 Claygate Clay dr	27.00	0.670	0.00	27.00	0.500	0.00
3 London Clay und	0.00	0.670	0.00	0.00	0.500	0.00
4 London Clay dr	25.00	0.670	0.00	25.00	0.500	0.00

GROUND WATER CONDITIONS

Density of water = 9.810 kN/m3

	Left side	Right side
Initial water table elevation	49.40	49.40

Automatic water pressure balancing at toe of wall : No

Water profile no.	Left side				Right side			
	Point no.	Elev. m	Piezo elev. m	Water press. kN/m2	Point no.	Elev. m	Piezo elev. m	Water press. kN/m2
1	1	49.40	49.40	0.0	1	47.50	47.50	0.0 MC+WC
2	1	49.40	49.40	0.0	1	43.00	43.00	0.0 MC+WC
3	1	49.40	49.40	0.0	1	43.65	43.65	0.0 MC+WC
					2	43.65	49.40	56.4

WALL PROPERTIES

Type of structure = Fully Embedded Wall
 Elevation of toe of wall = 40.75
 Maximum finite element length = 0.50 m
 Youngs modulus of wall E = 1.9600E+07 kN/m2
 Moment of inertia of wall I = 3.0968E-03 m4/m run
 E.I = 60696 kN.m2/m run
 Yield Moment of wall = Not defined

STRUTS and ANCHORS

Strut/ anchor no.	Elev.	Strut spacing m	X-section area of strut sq.m	Youngs modulus kN/m ²	Free length m	Inclin -ation (degs)	Pre- stress /strut kN	Tension allowed
1	48.35	1.00	0.400000	1.400E+07	5.00	0.00	0	No
2	43.85	1.00	0.300000	1.400E+07	5.00	0.00	0	No

SURCHARGE LOADS

Surch -arge no.	Elev.	Distance from wall	Length parallel to wall	Width perpend. to wall	Surcharge ----- kN/m ² ----- Near edge Far edge		Equiv. soil type	Partial factor/ Category
1	49.75	0.50(L)	10.00	10.00	10.00	=	N/A	1.10 Var
2	43.65	-0.00(R)	10.00	10.00	57.00	=	N/A	1.00 P/F

Note: L = Left side, R = Right side

Limit State Categories P/U = Permanent Unfavourable

P/F = Permanent Favourable

Var = Variable (unfavourable)

CONSTRUCTION STAGES

Construction stage no.	Stage description
1	Apply surcharge no.1 at elevation 49.75
2	Apply water pressure profile no.1 (Mod. Conserv.)
3	Excavate to elevation 47.85 on RIGHT side
4	Install strut or anchor no.1 at elevation 48.35
5	Apply water pressure profile no.2 (Mod. Conserv.)
6	Excavate to elevation 43.18 on RIGHT side
7	Fill to elevation 43.65 on RIGHT side with soil type 1
8	Install strut or anchor no.2 at elevation 43.85
9	Change EI of wall to 43355 kN.m ² /m run Yield moment not defined Allow wall to relax with new modulus value
10	Change properties of soil type 3 to soil type 4 Ko pressures will not be reset
11	Apply surcharge no.2 at elevation 43.65 No analysis at this stage
12	Apply water pressure profile no.3 (Mod. Conserv.)

FACTORS OF SAFETY and ANALYSIS OPTIONS

Limit State options: ULS DAL Combination 1

Water pressures : Moderately Conservative

Partial factor on C' = 1.000

Partial factor on Phi' = 1.000

Partial factor on Cu = 1.000

Partial factor on Soil Modulus = 1.000

Partial factor on Permanent Unfavourable loads = 1.000

Partial factor on Permanent Favourable loads = 1.000

Partial factor on Variable Unfavourable loads = 1.100

Design factor on calculated Bending Moments = 1.350

Parameters for undrained strata:

Minimum equivalent fluid density = 5.00 kN/m³

Maximum depth of water filled tension crack = 0.00 m

Bending moment and displacement calculation:

Method - Subgrade reaction model using Influence Coefficients

Open Tension Crack analysis? - No

Non-linear Modulus Parameter (L) = 9.000 m

Boundary conditions:

Length of wall (normal to plane of analysis) = 50.00 m

Width of excavation on Left side of wall = 50.00 m

Width of excavation on Right side of wall = 50.00 m

Distance to rigid boundary on Left side = 50.00 m

Distance to rigid boundary on Right side = 50.00 m

OUTPUT OPTIONS

Stage no.	Stage description	Output options		
		Displacement	Active, Graph.	Passive output
		Bending mom.	pressures	
		Shear force		
1	Apply surcharge no.1 at elev. 49.75	No	No	No
2	Apply water pressure profile no.1	Yes	Yes	Yes
3	Excav. to elev. 47.85 on RIGHT side	Yes	Yes	Yes
4	Install strut no.1 at elev. 48.35	Yes	Yes	Yes
5	Apply water pressure profile no.2	Yes	Yes	Yes
6	Excav. to elev. 43.18 on RIGHT side	Yes	Yes	Yes
7	Fill to elev. 43.65 on RIGHT side	Yes	Yes	Yes
8	Install strut no.2 at elev. 43.85	Yes	Yes	Yes
9	Change EI of wall to 43355kN.m ² /m run	No	No	No
10	Change soil type 3 to soil type 4	No	No	No
11	Apply surcharge no.2 at elev. 43.65	No	No	No
12	Apply water pressure profile no.3	No	No	No
*	Summary output	Yes	-	Yes

Program WALLAP - Copyright (C) 2017 by DL Borin, distributed by GEOSOLVE
 150 St. Alphonsus Road, London SW4 7BW, UK www.geosolve.co.uk

PILEDESIGNS LTD
 Program: WALLAP Version 6.06 Revision A51.B69.R54
 Licensed from GEOSOLVE
 Data filename/Run ID: Hampstead_Wall_1_450mm_rev_01_ULS1
 Hampstead - 24-26 Redington Gardens
 Wall 1, Secant-ULS1, 450 dia @ 650 - run 01

Sheet No.
 Job No. 21495
 Made by : DBS
 Date: 1-10-2018
 Checked :

Units: kN,m

Stage No. 3 Excavate to elevation 47.85 on RIGHT side

BENDING MOMENT and DISPLACEMENT ANALYSIS of Fully Embedded Wall

Analysis options

Length of wall perpendicular to section = 50.00m
 Subgrade reaction model - Boussinesq Influence coefficients
 Soil deformations are elastic until the active or passive limit is reached
 Open Tension Crack analysis - No

Rigid boundaries: Left side 50.00 from wall
 Right side 50.00 from wall

Limit State: ULS DA1 Combination 1

Calculated Bending Moments and Strut Forces are to be multiplied by a factor of 1.35 to obtain values for structural design. See summary for factored values.

Node no.	Y coord	Nett pressure kN/m2	Wall disp. m	Wall rotation rad.	Shear force kN/m	Bending moment kN.m/m	Strut forces kN/m	EI of wall kN.m2/m
1	49.75	0.00	0.012	2.74E-03	0.0	-0.0		60696
2	49.40	2.45	0.011	2.74E-03	0.4	0.2		60696
3	49.14	6.35	0.010	2.74E-03	1.6	0.4		60696
4	48.88	10.17	0.009	2.74E-03	3.8	1.1		60696
5	48.61	13.86	0.009	2.73E-03	6.9	2.4		60696
6	48.35	17.43	0.008	2.71E-03	11.0	4.8		60696
7	47.85	24.05	0.007	2.64E-03	21.4	12.8		60696
8	47.50	6.89	0.006	2.54E-03	26.8	21.4		60696
		5.19	0.006	2.54E-03	26.8	21.4		
9	47.00	-9.99	0.004	2.31E-03	25.6	34.7		60696
10	46.50	-25.23	0.003	1.98E-03	16.8	45.6		60696
11	46.00	-33.80	0.003	1.58E-03	2.0	52.2		60696
12	45.50	-18.35	0.002	1.16E-03	-11.0	49.0		60696
13	45.00	-7.87	0.001	7.94E-04	-17.6	41.2		60696
		-10.70	0.001	7.94E-04	-17.6	41.2		
14	44.50	0.43	0.001	4.96E-04	-20.1	31.0		60696
15	44.17	4.87	0.001	3.48E-04	-19.3	24.5		60696
16	43.85	7.53	0.001	2.33E-04	-17.2	18.5		60696
17	43.65	8.45	0.001	1.77E-04	-15.7	15.2		60696
18	43.18	8.98	0.001	8.47E-05	-11.6	8.8		60696
19	43.00	8.74	0.001	6.15E-05	-10.0	6.8		60696
20	42.50	7.28	0.001	2.13E-05	-6.0	2.9		60696
21	42.00	5.18	0.001	5.76E-06	-2.8	0.9		60696
22	41.50	2.87	0.001	1.95E-06	-0.8	0.1		60696
23	41.13	1.11	0.001	1.87E-06	-0.1	-0.0		60696
24	40.75	-0.67	0.001	2.00E-06	0.0	-0.0		---

Node no.	Y coord	LEFT side					Total earth pressure kN/m2	Coeff. of subgrade reaction kN/m3
		Water press. kN/m2	Vertical	Active limit	Passive limit	Earth pressure kN/m2		
1	49.75	0.00	0.00	0.00	0.00	0.00	0.00	3581
2	49.40	0.00	7.29	2.45	25.08	2.45	2.45a	3581
3	49.14	2.58	11.22	3.78	38.61	3.78	6.35a	3581
4	48.88	5.15	14.92	5.02	51.37	5.02	10.17a	3581
5	48.61	7.73	18.22	6.13	62.72	6.13	13.86a	3581
6	48.35	10.30	21.19	7.13	72.94	7.13	17.43a	3581
7	47.85	15.21	26.26	8.84	90.40	8.84	24.05a	3581
8	47.50	18.64	29.52	9.94	101.62	9.94	28.58a	3581
		18.64	29.52	9.52	107.66	9.52	28.16a	10336

(continued)

Stage No.3 Excavate to elevation 47.85 on RIGHT side

Node no.	Y coord	LEFT side					Total earth pressure kN/m2	Coeff. of subgrade reaction kN/m3
		Water press. kN/m2	Vertic -al kN/m2	Effective Active limit kN/m2	Effective Passive limit kN/m2	Earth pressure kN/m2		
9	47.00	23.54	34.42	11.10	125.52	11.10	34.65a	10336
10	46.50	28.45	39.12	12.62	142.65	12.62	41.07a	10336
11	46.00	33.35	43.68	14.09	159.28	20.27	53.62	10336
12	45.50	38.26	48.14	15.53	175.57	31.57	69.83	10336
13	45.00	43.16	52.55	16.95	191.63	40.74	83.90	10336
		Total>	95.71	23.75m	215.22	72.25	72.25	19938
14	44.50	Total>	105.48	26.25m	230.96	87.04	87.04	20935
15	44.17	Total>	111.81	27.88m	241.18	95.44	95.44	21583
16	43.85	Total>	118.14	29.50m	251.39	103.06	103.06	22231
17	43.65	Total>	122.03	30.50m	257.67	107.44	107.44	22630
18	43.18	Total>	131.16	32.85m	272.42	117.01	117.01	23567
19	43.00	Total>	134.66	33.75m	278.07	120.47	120.47	23926
20	42.50	Total>	144.37	36.25m	293.76	129.75	129.75	24923
21	42.00	Total>	154.09	38.75m	309.46	138.74	138.74	25920
22	41.50	Total>	163.82	41.25m	325.16	147.64	147.64	26917
23	41.13	Total>	171.12	43.13m	336.94	154.31	154.31	27665
24	40.75	Total>	176.46	45.00m	346.76	160.97	160.97	28412

Node no.	Y coord	RIGHT side					Total earth pressure kN/m2	Coeff. of subgrade reaction kN/m3
		Water press. kN/m2	Vertic -al kN/m2	Effective Active limit kN/m2	Effective Passive limit kN/m2	Earth pressure kN/m2		
1	49.75	0.00	0.00	0.00	0.00	0.00	0.00	0.0
2	49.40	0.00	0.00	0.00	0.00	0.00	0.00	0.0
3	49.14	0.00	0.00	0.00	0.00	0.00	0.00	0.0
4	48.88	0.00	0.00	0.00	0.00	0.00	0.00	0.0
5	48.61	0.00	0.00	0.00	0.00	0.00	0.00	0.0
6	48.35	0.00	0.00	0.00	0.00	0.00	0.00	0.0
7	47.85	0.00	0.00	0.00	0.00	0.00	0.00	0.0
		0.00	0.00	0.00	0.00	0.00	0.00	4851
8	47.50	0.00	6.30	2.12	21.69	21.69	21.69p	4851
		0.00	6.30	2.03	22.98	22.98	22.98p	14031
9	47.00	4.90	10.90	3.51	39.73	39.73	44.64p	14031
10	46.50	9.81	15.49	5.00	56.49	56.49	66.30p	14031
11	46.00	14.71	20.09	6.48	73.25	72.71	87.42	14031
12	45.50	19.62	24.68	7.96	90.01	68.56	88.18	14031
13	45.00	24.52	29.28	9.44	106.77	67.25	91.77	14031
		Total>	53.80	14.25m	173.31	82.95	82.95	26531
14	44.50	Total>	63.80	16.75m	189.28	86.62	86.62	27857
15	44.17	Total>	70.31	18.37m	199.67	90.58	90.58	28719
16	43.85	Total>	76.81	20.00m	210.06	95.53	95.53	29582
17	43.65	Total>	80.81	21.00m	216.45	98.99	98.99	30112
18	43.18	Total>	90.21	23.35m	231.47	108.02	108.02	31359
19	43.00	Total>	93.81	24.25m	237.22	111.73	111.73	31837
20	42.50	Total>	103.82	26.75m	253.20	122.47	122.47	33163
21	42.00	Total>	113.82	29.25m	269.18	133.56	133.56	34490
22	41.50	Total>	123.83	31.75m	285.17	144.77	144.77	35816
23	41.13	Total>	131.33	33.62m	297.15	153.20	153.20	36811
24	40.75	Total>	138.84	35.50m	309.14	161.64	161.64	37806

Note: 41.07a Soil pressure at active limit
66.30p Soil pressure at passive limit

Units: kN,m

Stage No.3 Excav. to elev. 47.85 on RIGHT side

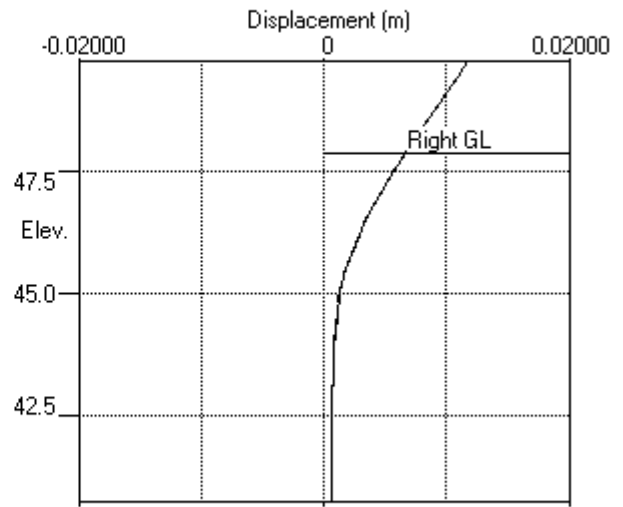
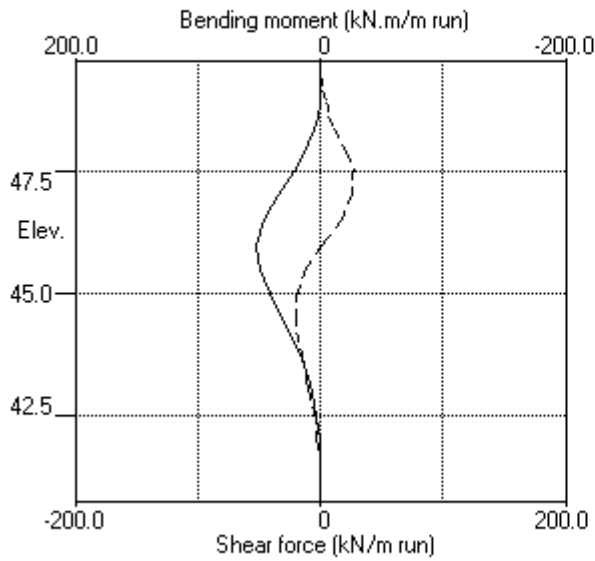

Stage No.3 Excav. to elev. 47.85 on RIGHT side

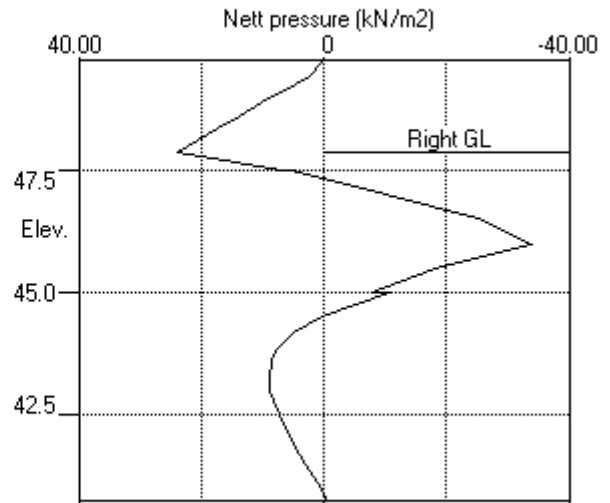
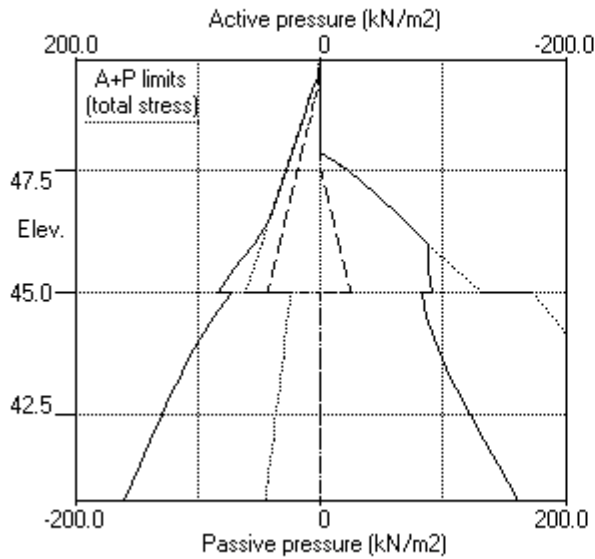

PILEDESIGNS LTD
 Program: WALLAP Version 6.06 Revision A51.B69.R54
 Licensed from GEOSOLVE
 Data filename/Run ID: Hampstead_Wall_1_450mm_rev_01_ULS1
 Hampstead - 24-26 Redington Gardens
 Wall 1, Secant-ULS1, 450 dia @ 650 - run 01

Sheet No.
 Job No. 21495
 Made by : DBS
 Date: 1-10-2018
 Checked :

Units: kN,m

Stage No. 6 Excavate to elevation 43.18 on RIGHT side

BENDING MOMENT and DISPLACEMENT ANALYSIS of Fully Embedded Wall

Analysis options

Length of wall perpendicular to section = 50.00m
 Subgrade reaction model - Boussinesq Influence coefficients
 Soil deformations are elastic until the active or passive limit is reached
 Open Tension Crack analysis - No

Rigid boundaries: Left side 50.00 from wall
 Right side 50.00 from wall

Limit State: ULS DA1 Combination 1

Calculated Bending Moments and Strut Forces are to be multiplied by a factor of 1.35 to obtain values for structural design. See summary for factored values.

Node no.	Y coord	Nett pressure kN/m2	Wall disp. m	Wall rotation rad.	Shear force kN/m	Bending moment kN.m/m	Strut forces kN/m	EI of wall kN.m2/m
1	49.75	0.00	0.004	-2.55E-03	0.0	-0.0		60696
2	49.40	25.08	0.005	-2.55E-03	4.4	0.6		60696
3	49.14	36.26	0.006	-2.55E-03	12.4	2.4		60696
4	48.88	29.91	0.007	-2.57E-03	21.1	7.0		60696
5	48.61	23.36	0.007	-2.62E-03	28.1	13.6		60696
6	48.35	17.43	0.008	-2.69E-03	33.5	21.8	125.2	60696
		17.43	0.008	-2.69E-03	-91.7	21.8		
7	47.85	24.05	0.009	-2.70E-03	-81.3	-21.5		60696
8	47.50	28.58	0.010	-2.49E-03	-72.1	-48.4		60696
		28.16	0.010	-2.49E-03	-72.1	-48.4		
9	47.00	34.65	0.011	-1.96E-03	-56.4	-80.7		60696
10	46.50	41.07	0.012	-1.20E-03	-37.5	-104.4		60696
11	46.00	47.44	0.013	-2.97E-04	-15.4	-115.9		60696
12	45.50	53.79	0.013	6.66E-04	10.0	-118.0		60696
13	45.00	60.11	0.012	1.59E-03	38.4	-106.5		60696
		23.75	0.012	1.59E-03	38.4	-106.5		
14	44.50	26.25	0.011	2.37E-03	50.9	-84.8		60696
15	44.17	27.88	0.010	2.78E-03	59.7	-66.9		60696
16	43.85	29.50	0.009	3.08E-03	69.0	-46.1		60696
17	43.65	30.50	0.009	3.21E-03	75.0	-31.7		60696
18	43.18	32.85	0.007	3.31E-03	89.9	7.0		60696
		-108.40	0.007	3.31E-03	89.9	7.0		
19	43.00	-113.25	0.006	3.26E-03	70.0	21.4		60696
20	42.50	-103.73	0.005	2.99E-03	15.7	45.5		60696
21	42.00	-63.08	0.003	2.61E-03	-26.0	45.7		60696
22	41.50	-0.15	0.002	2.32E-03	-41.8	24.9		60696
23	41.13	46.24	0.001	2.22E-03	-33.1	9.2		60696
24	40.75	130.43	0.001	2.19E-03	0.0	0.0		---

At elev. 48.35 Strut force = 125.2 kN/strut = 125.2 kN/m run

Node no.	Y coord	LEFT side						Total earth pressure kN/m2	Coeff. of subgrade reaction kN/m3
		Water press. kN/m2	Vertic -al kN/m2	Active limit kN/m2	Passive limit kN/m2	Earth pressure kN/m2			
1	49.75	0.00	0.00	0.00	0.00	0.00	0.00	7301	
2	49.40	0.00	7.29	2.45	25.08	25.08	25.08p	7301	
3	49.14	2.58	11.22	3.78	38.61	33.68	36.26	7301	
4	48.88	5.15	14.92	5.02	51.37	24.76	29.91	7301	
5	48.61	7.73	18.22	6.13	62.72	15.64	23.36	7301	
6	48.35	10.30	21.19	7.13	72.94	7.13	17.43a	2310	

(continued)

Stage No.6 Excavate to elevation 43.18 on RIGHT side

Node no.	Y coord	LEFT side					Total earth pressure	Coeff. of subgrade reaction
		Water press.	Vertic -al	Effective Active limit	Effective Passive limit	Earth pressure		
		kN/m2	kN/m2	kN/m2	kN/m2	kN/m2	kN/m2	kN/m3
7	47.85	15.21	26.26	8.84	90.40	8.84	24.05a	2310
8	47.50	18.64	29.52	9.94	101.62	9.94	28.58a	2310
		18.64	29.52	9.52	107.66	9.52	28.16a	6635
9	47.00	23.54	34.42	11.10	125.52	11.10	34.65a	6635
10	46.50	28.45	39.12	12.62	142.65	12.62	41.07a	6635
11	46.00	33.35	43.68	14.09	159.28	14.09	47.44a	6635
12	45.50	38.26	48.14	15.53	175.57	15.53	53.79a	6635
13	45.00	43.16	52.55	16.95	191.63	16.95	60.11a	6635
		Total>	95.71	23.75m	215.22	23.75	23.75a	13416
14	44.50	Total>	105.48	26.25m	230.96	26.25	26.25a	14086
15	44.17	Total>	111.81	27.88m	241.18	27.88	27.88a	14522
16	43.85	Total>	118.14	29.50m	251.39	29.50	29.50a	14958
17	43.65	Total>	122.03	30.50m	257.67	30.50	30.50a	15227
18	43.18	Total>	131.16	32.85m	272.42	32.85	32.85a	15857
19	43.00	Total>	134.66	33.75m	278.07	33.75	33.75a	16099
20	42.50	Total>	144.37	36.25m	293.76	59.24	59.24	16769
21	42.00	Total>	154.09	38.75m	309.46	89.81	89.81	17440
22	41.50	Total>	163.82	41.25m	325.16	119.09	119.09	18111
23	41.13	Total>	171.12	43.13m	336.94	140.79	140.79	18614
24	40.75	Total>	176.46	45.00m	346.76	176.11	176.11	146569

Node no.	Y coord	RIGHT side					Total earth pressure	Coeff. of subgrade reaction
		Water press.	Vertic -al	Effective Active limit	Effective Passive limit	Earth pressure		
		kN/m2	kN/m2	kN/m2	kN/m2	kN/m2	kN/m2	kN/m3
1	49.75	0.00	0.00	0.00	0.00	0.00	0.00	0.0
2	49.40	0.00	0.00	0.00	0.00	0.00	0.00	0.0
3	49.14	0.00	0.00	0.00	0.00	0.00	0.00	0.0
4	48.88	0.00	0.00	0.00	0.00	0.00	0.00	0.0
5	48.61	0.00	0.00	0.00	0.00	0.00	0.00	0.0
6	48.35	0.00	0.00	0.00	0.00	0.00	0.00	0.0
7	47.85	0.00	0.00	0.00	0.00	0.00	0.00	0.0
8	47.50	0.00	0.00	0.00	0.00	0.00	0.00	0.0
9	47.00	0.00	0.00	0.00	0.00	0.00	0.00	0.0
10	46.50	0.00	0.00	0.00	0.00	0.00	0.00	0.0
11	46.00	0.00	0.00	0.00	0.00	0.00	0.00	0.0
12	45.50	0.00	0.00	0.00	0.00	0.00	0.00	0.0
13	45.00	0.00	0.00	0.00	0.00	0.00	0.00	0.0
14	44.50	0.00	0.00	0.00	0.00	0.00	0.00	0.0
15	44.17	0.00	0.00	0.00	0.00	0.00	0.00	0.0
16	43.85	0.00	0.00	0.00	0.00	0.00	0.00	0.0
17	43.65	0.00	0.00	0.00	0.00	0.00	0.00	0.0
18	43.18	0.00	0.00	0.00	0.00	0.00	0.00	0.0
		Total>	0.00	0.00	141.25	141.25	141.25p	35259
19	43.00	Total>	3.60	0.90m	147.00	147.00	147.00p	35796
20	42.50	Total>	13.60	3.40m	162.97	162.97	162.97p	37287
21	42.00	Total>	23.60	5.90m	178.95	152.89	152.89	38779
22	41.50	Total>	33.60	8.40m	194.93	119.24	119.24	40270
23	41.13	Total>	41.10	10.27m	206.91	94.55	94.55	41389
24	40.75	Total>	48.61	12.15m	218.90	45.68	45.68	271605

Note: 33.75a Soil pressure at active limit
162.97p Soil pressure at passive limit

Units: kN,m

Stage No.6 Excav. to elev. 43.18 on RIGHT side

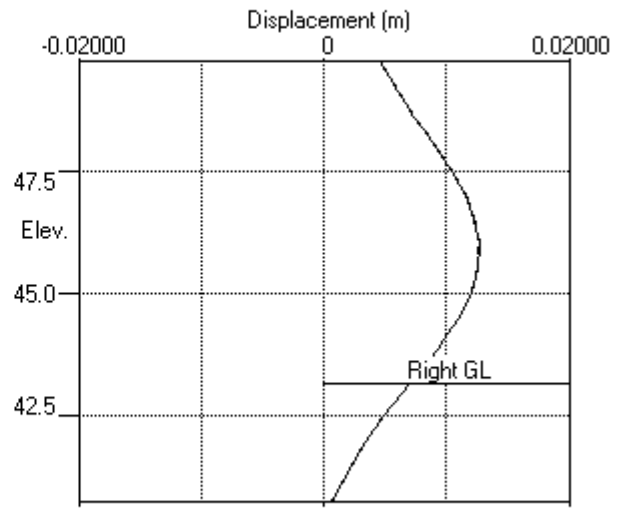
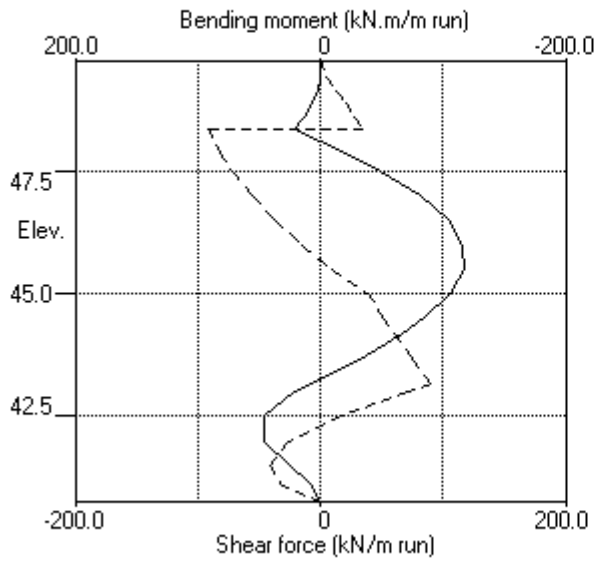

Stage No.6 Excav. to elev. 43.18 on RIGHT side

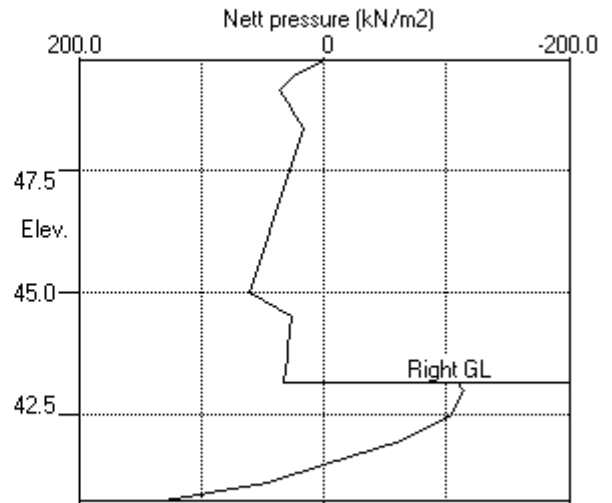
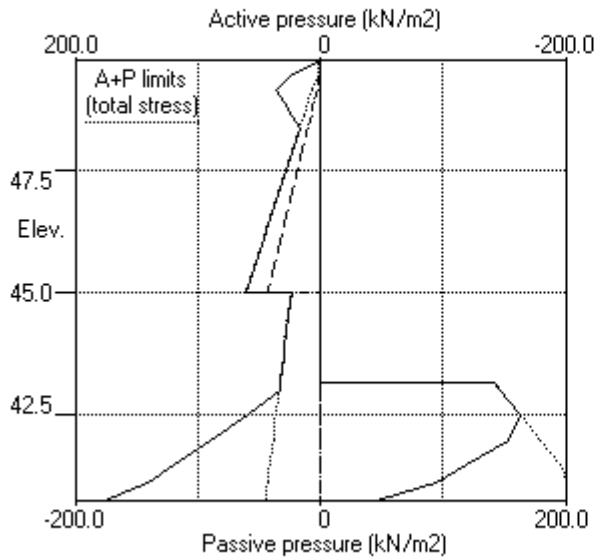

PILEDESIGNS LTD
 Program: WALLAP Version 6.06 Revision A51.B69.R54
 Licensed from GEOSOLVE
 Data filename/Run ID: Hampstead_Wall_1_450mm_rev_01_ULS1
 Hampstead - 24-26 Redington Gardens
 Wall 1, Secant-ULS1, 450 dia @ 650 - run 01

Sheet No.
 Job No. 21495
 Made by : DBS
 Date: 1-10-2018
 Checked :

Units: kN,m

Stage No. 7 Fill to elevation 43.65 on RIGHT side with soil type 1

BENDING MOMENT and DISPLACEMENT ANALYSIS of Fully Embedded Wall

Analysis options

Length of wall perpendicular to section = 50.00m
 Subgrade reaction model - Boussinesq Influence coefficients
 Soil deformations are elastic until the active or passive limit is reached
 Open Tension Crack analysis - No

Rigid boundaries: Left side 50.00 from wall
 Right side 50.00 from wall

Limit State: ULS DA1 Combination 1

Calculated Bending Moments and Strut Forces are to be multiplied by a factor of 1.35 to obtain values for structural design. See summary for factored values.

Node no.	Y coord	Nett pressure kN/m2	Wall disp. m	Wall rotation rad.	Shear force kN/m	Bending moment kN.m/m	Strut forces kN/m	EI of wall kN.m2/m
1	49.75	0.00	0.004	-2.54E-03	0.0	-0.0		60696
2	49.40	25.08	0.005	-2.55E-03	4.4	0.6		60696
3	49.14	36.26	0.006	-2.55E-03	12.4	2.4		60696
4	48.88	29.90	0.007	-2.57E-03	21.1	7.0		60696
5	48.61	23.36	0.007	-2.62E-03	28.1	13.6		60696
6	48.35	17.43	0.008	-2.69E-03	33.5	21.8	125.5	60696
		17.43	0.008	-2.69E-03	-92.1	21.8		
7	47.85	24.05	0.009	-2.69E-03	-81.7	-21.7		60696
8	47.50	28.58	0.010	-2.49E-03	-72.5	-48.7		60696
		28.17	0.010	-2.49E-03	-72.5	-48.7		
9	47.00	34.67	0.011	-1.96E-03	-56.8	-81.2		60696
10	46.50	41.12	0.012	-1.19E-03	-37.8	-105.0		60696
11	46.00	47.55	0.013	-2.80E-04	-15.7	-116.7		60696
12	45.50	53.99	0.013	6.89E-04	9.7	-119.0		60696
13	45.00	60.43	0.012	1.62E-03	38.3	-107.6		60696
		24.37	0.012	1.62E-03	38.3	-107.6		
14	44.50	27.23	0.011	2.41E-03	51.2	-85.8		60696
15	44.17	29.14	0.010	2.83E-03	60.4	-67.7		60696
16	43.85	31.09	0.009	3.13E-03	70.2	-46.6		60696
17	43.65	32.31	0.008	3.26E-03	76.5	-32.0		60696
18	43.18	32.37	0.007	3.36E-03	91.7	7.5		60696
		-111.80	0.007	3.36E-03	91.7	7.5		
19	43.00	-116.22	0.006	3.31E-03	71.2	22.1		60696
20	42.50	-105.54	0.005	3.03E-03	15.8	46.5		60696
21	42.00	-63.82	0.003	2.65E-03	-26.6	46.5		60696
22	41.50	0.11	0.002	2.35E-03	-42.5	25.2		60696
23	41.13	47.21	0.001	2.24E-03	-33.6	9.3		60696
24	40.75	132.14	0.000	2.22E-03	0.0	0.0		---

At elev. 48.35 Strut force = 125.5 kN/strut = 125.5 kN/m run

Node no.	Y coord	LEFT side						Total earth pressure kN/m2	Coeff. of subgrade reaction kN/m3
		Water press. kN/m2	Vertic -al kN/m2	Active limit kN/m2	Passive limit kN/m2	Earth pressure kN/m2			
1	49.75	0.00	0.00	0.00	0.00	0.00	0.00	4254	
2	49.40	0.00	7.29	2.45	25.08	25.08	25.08p	4254	
3	49.14	2.58	11.22	3.78	38.61	33.68	36.26	4254	
4	48.88	5.15	14.92	5.02	51.37	24.75	29.90	4254	
5	48.61	7.73	18.22	6.13	62.72	15.64	23.36	4254	
6	48.35	10.30	21.19	7.13	72.94	7.13	17.43a	4254	

(continued)

Stage No.7 Fill to elevation 43.65 on RIGHT side with soil type 1

Node no.	Y coord	----- LEFT side -----					Total earth pressure	Coeff. of subgrade reaction
		Water press. kN/m2	Vertic -al kN/m2	Effective Active limit kN/m2	Effective Passive limit kN/m2	Earth pressure kN/m2		
7	47.85	15.21	26.26	8.84	90.40	8.84	24.05a	4254
8	47.50	18.64	29.52	9.94	101.62	9.94	28.58a	3000
		18.64	29.52	9.52	107.66	9.53	28.17a	8644
9	47.00	23.54	34.42	11.10	125.52	11.12	34.67	8644
10	46.50	28.45	39.12	12.62	142.65	12.67	41.12	8644
11	46.00	33.35	43.68	14.09	159.28	14.20	47.55	8644
12	45.50	38.26	48.14	15.53	175.57	15.73	53.99	8644
13	45.00	43.16	52.55	16.95	191.63	17.27	60.43	8644
		Total>	95.71	23.75m	215.22	24.37	24.37	16936
14	44.50	Total>	105.48	26.25m	230.96	27.23	27.23	17783
15	44.17	Total>	111.81	27.88m	241.18	29.14	29.14	18333
16	43.85	Total>	118.14	29.50m	251.39	31.09	31.09	18883
17	43.65	Total>	122.03	30.50m	257.67	32.31	32.31	19222
18	43.18	Total>	131.16	32.85m	272.42	35.21	35.21	20018
19	43.00	Total>	134.66	33.75m	278.07	36.33	36.33	20323
20	42.50	Total>	144.37	36.25m	293.76	62.40	62.40	21170
21	42.00	Total>	154.09	38.75m	309.46	93.51	93.51	22017
22	41.50	Total>	163.82	41.25m	325.16	123.28	123.28	22863
23	41.13	Total>	171.12	43.13m	336.94	145.34	145.34	23498
24	40.75	Total>	176.46	45.00m	346.76	181.04	181.04	24133

Node no.	Y coord	----- RIGHT side -----					Total earth pressure	Coeff. of subgrade reaction
		Water press. kN/m2	Vertic -al kN/m2	Effective Active limit kN/m2	Effective Passive limit kN/m2	Earth pressure kN/m2		
1	49.75	0.00	0.00	0.00	0.00	0.00	0.00	0.0
2	49.40	0.00	0.00	0.00	0.00	0.00	0.00	0.0
3	49.14	0.00	0.00	0.00	0.00	0.00	0.00	0.0
4	48.88	0.00	0.00	0.00	0.00	0.00	0.00	0.0
5	48.61	0.00	0.00	0.00	0.00	0.00	0.00	0.0
6	48.35	0.00	0.00	0.00	0.00	0.00	0.00	0.0
7	47.85	0.00	0.00	0.00	0.00	0.00	0.00	0.0
8	47.50	0.00	0.00	0.00	0.00	0.00	0.00	0.0
9	47.00	0.00	0.00	0.00	0.00	0.00	0.00	0.0
10	46.50	0.00	0.00	0.00	0.00	0.00	0.00	0.0
11	46.00	0.00	0.00	0.00	0.00	0.00	0.00	0.0
12	45.50	0.00	0.00	0.00	0.00	0.00	0.00	0.0
13	45.00	0.00	0.00	0.00	0.00	0.00	0.00	0.0
14	44.50	0.00	0.00	0.00	0.00	0.00	0.00	0.0
15	44.17	0.00	0.00	0.00	0.00	0.00	0.00	0.0
16	43.85	0.00	0.00	0.00	0.00	0.00	0.00	0.0
17	43.65	0.00	0.00	0.00	0.00	0.00	0.00	0.0
		0.00	0.00	0.00	0.00	0.00	0.00	3000
18	43.18	0.00	8.46	2.85	29.12	2.85	2.85a	3000
		Total>	8.46	2.35m	149.71	147.01	147.01	20018
19	43.00	Total>	12.06	3.25m	155.46	152.55	152.55	20323
20	42.50	Total>	22.06	5.75m	171.44	167.94	167.94	21170
21	42.00	Total>	32.06	8.25m	187.41	157.32	157.32	22017
22	41.50	Total>	42.06	10.75m	203.39	123.17	123.17	22863
23	41.13	Total>	49.57	12.63m	215.38	98.13	98.13	23498
24	40.75	Total>	57.07	14.50m	227.36	48.89	48.89	24133

Run ID. Hampstead_Wall_1_450mm_rev_01_ULS1
Hampstead - 24-26 Redington Gardens
Wall 1, Secant-ULS1, 450 dia @ 650 - run 01

| Sheet No.
| Date: 1-10-2018
| Checked :

(continued)

Stage No.7 Fill to elevation 43.65 on RIGHT side with soil type 1
Note: 2.85a Soil pressure at active limit
 25.08p Soil pressure at passive limit

Units: kN,m

Stage No.7 Fill to elev. 43.65 on RIGHT side

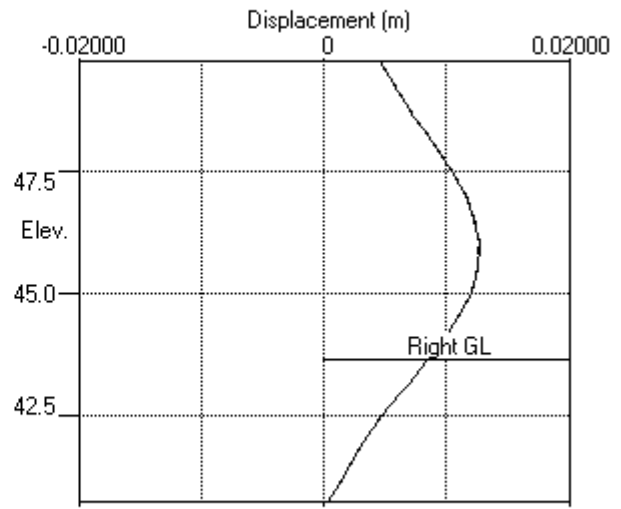
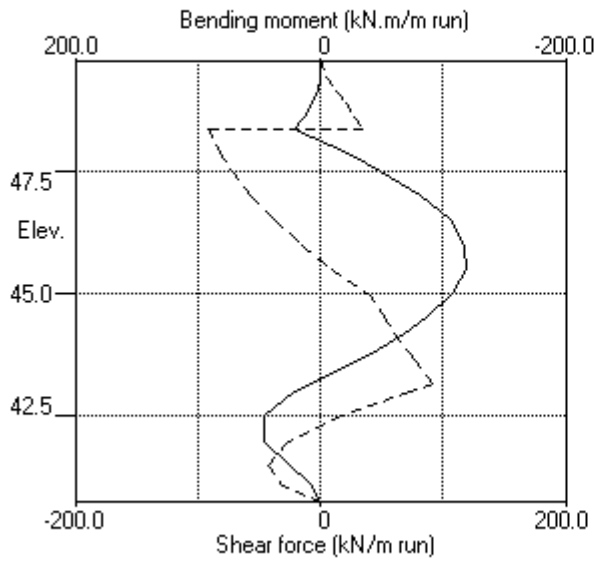

Stage No.7 Fill to elev. 43.65 on RIGHT side

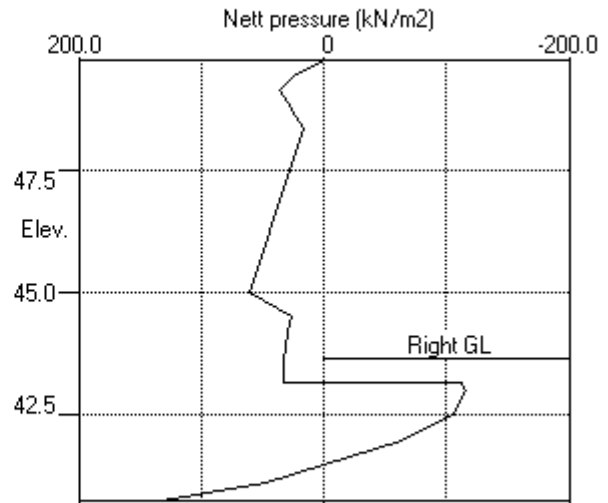
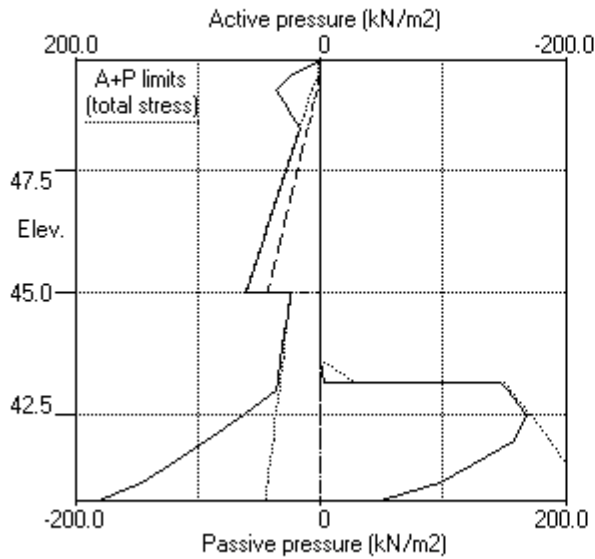

PILEDESIGNS LTD
 Program: WALLAP Version 6.06 Revision A51.B69.R54
 Licensed from GEOSOLVE
 Data filename/Run ID: Hampstead_Wall_1_450mm_rev_01_ULS1
 Hampstead - 24-26 Redington Gardens
 Wall 1, Secant-ULS1, 450 dia @ 650 - run 01

Sheet No.
 Job No. 21495
 Made by : DBS
 Date: 1-10-2018
 Checked :

Units: kN,m

Stage No. 9 Change EI of wall to 43355 kN.m²/m run
 Yield moment not defined
 Allow wall to relax with new modulus value

BENDING MOMENT and DISPLACEMENT ANALYSIS of Fully Embedded Wall

Analysis options

Length of wall perpendicular to section = 50.00m
 Subgrade reaction model - Boussinesq Influence coefficients
 Soil deformations are elastic until the active or passive limit is reached
 Open Tension Crack analysis - No

Rigid boundaries: Left side 50.00 from wall
 Right side 50.00 from wall

Limit State: ULS DA1 Combination 1

Calculated Bending Moments and Strut Forces are to be multiplied by a factor
 of 1.35 to obtain values for structural design. See summary for factored values.

Node no.	Y coord	Nett pressure kN/m ²	Wall disp. m	Wall rotation rad.	Shear force kN/m	Bending moment kN.m/m	Strut forces kN/m	EI of wall kN.m ² /m
1	49.75	0.00	0.004	-2.99E-03	0.0	-0.0		43355
2	49.40	25.08	0.005	-2.99E-03	4.4	0.6		43355
3	49.14	38.90	0.006	-3.00E-03	12.8	2.4		43355
4	48.88	31.71	0.006	-3.03E-03	22.1	7.1		43355
5	48.61	24.30	0.007	-3.09E-03	29.4	14.0		43355
6	48.35	17.46	0.008	-3.21E-03	34.9	22.5	121.3	43355
		17.46	0.008	-3.21E-03	-86.4	22.5		
7	47.85	24.05	0.010	-3.23E-03	-76.0	-18.8		43355
8	47.50	28.58	0.011	-2.99E-03	-66.8	-44.3		43355
		28.16	0.011	-2.99E-03	-66.8	-44.3		
9	47.00	34.65	0.012	-2.32E-03	-51.1	-74.6		43355
10	46.50	41.07	0.013	-1.36E-03	-32.2	-96.2		43355
11	46.00	47.44	0.013	-2.31E-04	-10.1	-105.7		43355
12	45.50	53.79	0.013	9.48E-04	15.3	-105.8		43355
13	45.00	60.11	0.013	2.04E-03	43.7	-92.3		43355
		23.75	0.013	2.04E-03	43.7	-92.3		
14	44.50	26.25	0.011	2.91E-03	56.2	-68.5		43355
15	44.17	27.88	0.010	3.32E-03	65.0	-49.2		43355
16	43.85	30.55	0.009	3.56E-03	74.5	-27.0	24.9	43355
		30.55	0.009	3.56E-03	49.6	-27.0		
17	43.65	33.51	0.008	3.63E-03	56.0	-15.5		43355
18	43.18	37.14	0.007	3.59E-03	72.6	16.5		43355
		-102.24	0.007	3.59E-03	72.6	16.5		
19	43.00	-104.68	0.006	3.49E-03	54.0	28.7		43355
20	42.50	-91.17	0.004	3.04E-03	5.1	47.5		43355
21	42.00	-50.79	0.003	2.51E-03	-30.4	44.7		43355
22	41.50	8.24	0.002	2.12E-03	-41.1	23.2		43355
23	41.13	50.26	0.001	1.99E-03	-30.1	8.1		43355
24	40.75	110.29	0.000	1.96E-03	0.0	0.0		---
At elev. 48.35		Strut force =		121.3 kN/strut =	121.3 kN/m run			
At elev. 43.85		Strut force =		24.9 kN/strut =	24.9 kN/m run			

(continued)

Stage No.9 Change EI of wall to 43355 kN.m2/m run
 Yield moment not defined
 Allow wall to relax with new modulus value

Node no.	Y coord	LEFT side					Total earth pressure	Coeff. of subgrade reaction
		Water press.	Vertic -al	Active limit	Passive limit	Earth pressure		
		kN/m2	kN/m2	kN/m2	kN/m2	kN/m2	kN/m2	kN/m3
1	49.75	0.00	0.00	0.00	0.00	0.00	0.00	7076
2	49.40	0.00	7.29	2.45	25.08	25.08	25.08p	7076
3	49.14	2.58	11.22	3.78	38.61	36.33	38.90	7076
4	48.88	5.15	14.92	5.02	51.37	26.56	31.71	7076
5	48.61	7.73	18.22	6.13	62.72	16.58	24.30	7076
6	48.35	10.30	21.19	7.13	72.94	7.16	17.46	7076
7	47.85	15.21	26.26	8.84	90.40	8.84	24.05a	2905
8	47.50	18.64	29.52	9.94	101.62	9.94	28.58a	2905
		18.64	29.52	9.52	107.66	9.52	28.16a	8369
9	47.00	23.54	34.42	11.10	125.52	11.10	34.65a	8369
10	46.50	28.45	39.12	12.62	142.65	12.62	41.07a	8369
11	46.00	33.35	43.68	14.09	159.28	14.09	47.44a	8369
12	45.50	38.26	48.14	15.53	175.57	15.53	53.79a	8369
13	45.00	43.16	52.55	16.95	191.63	16.95	60.11a	8369
		Total>	95.71	23.75m	215.22	23.75	23.75a	16450
14	44.50	Total>	105.48	26.25m	230.96	26.25	26.25a	17273
15	44.17	Total>	111.81	27.88m	241.18	27.88	27.88a	17807
16	43.85	Total>	118.14	29.50m	251.39	30.55	30.55	18342
17	43.65	Total>	122.03	30.50m	257.67	33.51	33.51	23658
18	43.18	Total>	131.16	32.85m	272.42	39.99	39.99	24638
19	43.00	Total>	134.66	33.75m	278.07	42.10	42.10	25013
20	42.50	Total>	144.37	36.25m	293.76	69.59	69.59	26055
21	42.00	Total>	154.09	38.75m	309.46	100.02	100.02	27097
22	41.50	Total>	163.82	41.25m	325.16	127.35	127.35	28140
23	41.13	Total>	171.12	43.13m	336.94	146.86	146.86	28921
24	40.75	Total>	176.46	45.00m	346.76	170.11	170.11	248139

Node no.	Y coord	RIGHT side					Total earth pressure	Coeff. of subgrade reaction
		Water press.	Vertic -al	Active limit	Passive limit	Earth pressure		
		kN/m2	kN/m2	kN/m2	kN/m2	kN/m2	kN/m2	kN/m3
1	49.75	0.00	0.00	0.00	0.00	0.00	0.00	0.0
2	49.40	0.00	0.00	0.00	0.00	0.00	0.00	0.0
3	49.14	0.00	0.00	0.00	0.00	0.00	0.00	0.0
4	48.88	0.00	0.00	0.00	0.00	0.00	0.00	0.0
5	48.61	0.00	0.00	0.00	0.00	0.00	0.00	0.0
6	48.35	0.00	0.00	0.00	0.00	0.00	0.00	0.0
7	47.85	0.00	0.00	0.00	0.00	0.00	0.00	0.0
8	47.50	0.00	0.00	0.00	0.00	0.00	0.00	0.0
9	47.00	0.00	0.00	0.00	0.00	0.00	0.00	0.0
10	46.50	0.00	0.00	0.00	0.00	0.00	0.00	0.0
11	46.00	0.00	0.00	0.00	0.00	0.00	0.00	0.0
12	45.50	0.00	0.00	0.00	0.00	0.00	0.00	0.0
13	45.00	0.00	0.00	0.00	0.00	0.00	0.00	0.0
14	44.50	0.00	0.00	0.00	0.00	0.00	0.00	0.0
15	44.17	0.00	0.00	0.00	0.00	0.00	0.00	0.0
16	43.85	0.00	0.00	0.00	0.00	0.00	0.00	0.0
17	43.65	0.00	0.00	0.00	0.00	0.00	0.00	0.0
		0.00	0.00	0.00	0.00	0.00	0.00	3756
18	43.18	0.00	8.46	2.85	29.12	2.85	2.85a	3756
		Total>	8.46	2.35m	149.71	142.23	142.23	24638

(continued)

Stage No.9 Change EI of wall to 43355 kN.m2/m run
 Yield moment not defined
 Allow wall to relax with new modulus value

Node no.	Y coord	----- RIGHT side -----						Total earth pressure	Coeff. of subgrade reaction
		Water press.	Vertic -al	Effective Active limit	Effective Passive limit	Earth pressure	Earth pressure		
		kN/m2	kN/m2	kN/m2	kN/m2	kN/m2	kN/m2	kN/m3	
19	43.00	Total>	12.06	3.25m	155.46	146.78	146.78	25013	
20	42.50	Total>	22.06	5.75m	171.44	160.76	160.76	26055	
21	42.00	Total>	32.06	8.25m	187.41	150.81	150.81	27097	
22	41.50	Total>	42.06	10.75m	203.39	119.11	119.11	28140	
23	41.13	Total>	49.57	12.63m	215.38	96.60	96.60	28921	
24	40.75	Total>	57.07	14.50m	227.36	59.82	59.82	248139	

Note: 2.85a Soil pressure at active limit
 25.08p Soil pressure at passive limit

Units: kN,m

Stage No.9 Change EI of wall to 43355kN.m2/m run

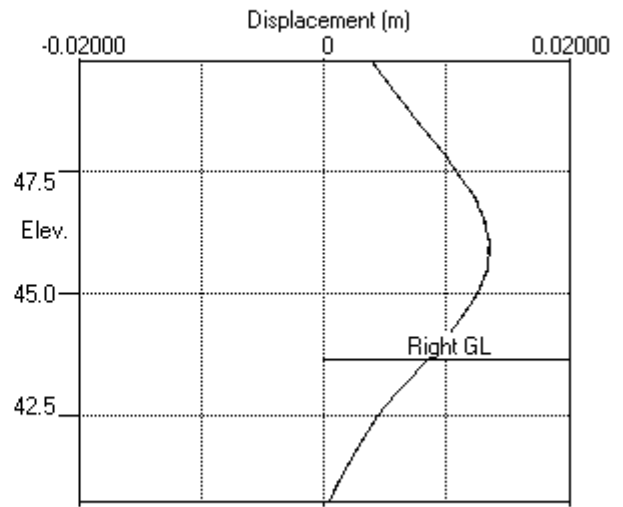
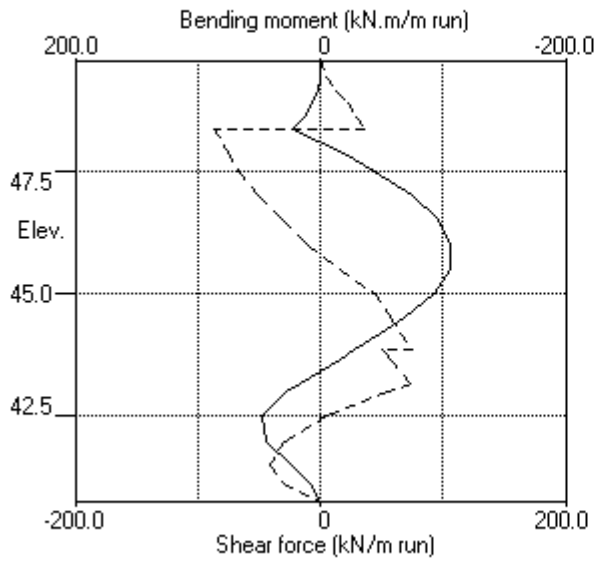

Stage No.9 Change EI of wall to 43355kN.m2/m run

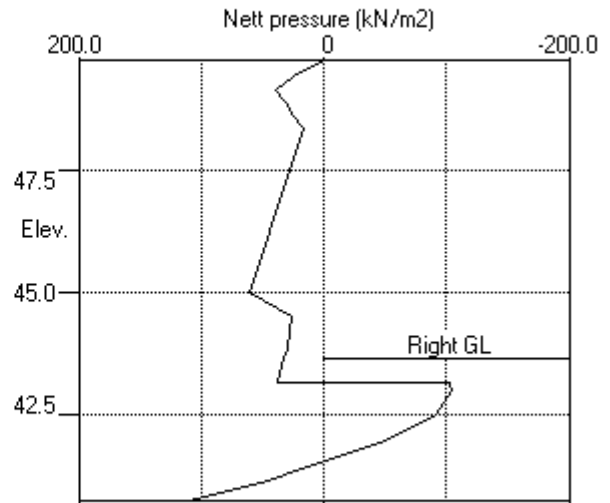
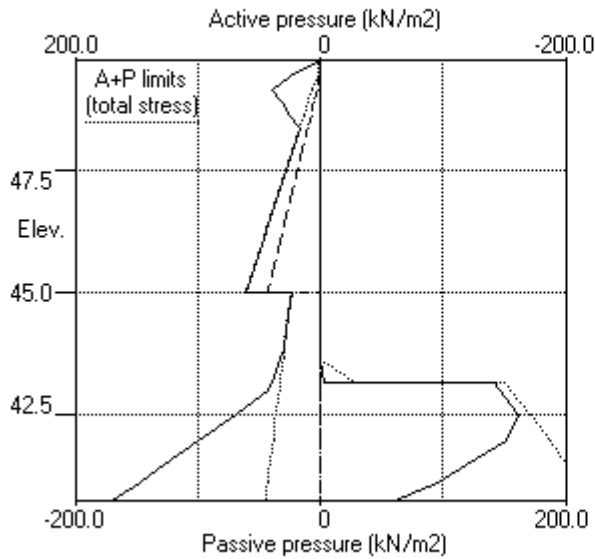

PILEDESIGNS LTD
 Program: WALLAP Version 6.06 Revision A51.B69.R54
 Licensed from GEOSOLVE
 Data filename/Run ID: Hampstead_Wall_1_450mm_rev_01_ULS1
 Hampstead - 24-26 Redington Gardens
 Wall 1, Secant-ULS1, 450 dia @ 650 - run 01

Sheet No.
 Job No. 21495
 Made by : DBS
 Date: 1-10-2018
 Checked :

Units: kN,m

Stage No. 10 Change properties of soil type 3 to soil type 4
 Ko pressures will not be reset

BENDING MOMENT and DISPLACEMENT ANALYSIS of Fully Embedded Wall

Analysis options

Length of wall perpendicular to section = 50.00m
 Subgrade reaction model - Boussinesq Influence coefficients
 Soil deformations are elastic until the active or passive limit is reached
 Open Tension Crack analysis - No

Rigid boundaries: Left side 50.00 from wall
 Right side 50.00 from wall

Limit State: ULS DA1 Combination 1

Calculated Bending Moments and Strut Forces are to be multiplied by a factor
 of 1.35 to obtain values for structural design. See summary for factored values.

Node no.	Y coord	Nett pressure kN/m ²	Wall disp. m	Wall rotation rad.	Shear force kN/m	Bending moment kN.m/m	Strut forces kN/m	EI of wall kN.m ² /m
1	49.75	0.00	0.004	-2.56E-03	0.0	-0.0		43355
2	49.40	21.81	0.005	-2.56E-03	3.8	0.6		43355
3	49.14	36.46	0.006	-2.57E-03	11.5	2.1		43355
4	48.88	30.08	0.007	-2.60E-03	20.2	6.4		43355
5	48.61	23.51	0.007	-2.66E-03	27.2	12.7		43355
6	48.35	17.48	0.008	-2.76E-03	32.6	20.6	114.5	43355
		17.48	0.008	-2.76E-03	-81.8	20.6		
7	47.85	24.73	0.009	-2.78E-03	-71.3	-18.4		43355
8	47.50	29.72	0.010	-2.54E-03	-61.8	-42.2		43355
		31.45	0.010	-2.54E-03	-61.8	-42.2		
9	47.00	39.73	0.012	-1.91E-03	-44.0	-69.5		43355
10	46.50	47.69	0.012	-1.04E-03	-22.1	-86.9		43355
11	46.00	55.14	0.013	-5.17E-05	3.6	-90.6		43355
12	45.50	61.81	0.012	9.08E-04	32.8	-82.9		43355
13	45.00	67.33	0.012	1.68E-03	65.1	-59.6		43355
		61.62	0.012	1.68E-03	65.1	-59.6		
14	44.50	68.23	0.011	2.08E-03	97.6	-20.1		43355
15	44.17	72.53	0.010	2.07E-03	120.5	14.8		43355
16	43.85	76.82	0.009	1.75E-03	144.7	57.5	241.1	43355
		76.82	0.009	1.75E-03	-96.3	57.5		
17	43.65	79.46	0.009	1.50E-03	-80.7	40.6		43355
18	43.18	76.49	0.008	1.17E-03	-44.1	13.5		43355
		58.14	0.008	1.17E-03	-44.1	13.5		
19	43.00	48.80	0.008	1.12E-03	-34.4	7.2		43355
20	42.50	33.92	0.008	1.07E-03	-13.8	-0.3		43355
21	42.00	19.03	0.007	1.06E-03	-0.5	0.9		43355
22	41.50	4.15	0.007	1.07E-03	5.3	-0.0		43355
23	41.13	-7.02	0.006	1.07E-03	4.7	0.7		43355
24	40.75	-18.19	0.006	1.07E-03	0.0	0.0		---
At elev. 48.35 Strut force =			114.5 kN/strut =		114.5 kN/m run			
At elev. 43.85 Strut force =			241.1 kN/strut =		241.1 kN/m run			

(continued)

Stage No.10 Change properties of soil type 3 to soil type 4
Ko pressures will not be reset

Node no.	Y coord	LEFT side						Total earth pressure kN/m2	Coeff. of subgrade reaction kN/m3
		Effective stresses							
		Water press. kN/m2	Vertic -al kN/m2	Active limit kN/m2	Passive limit kN/m2	Earth pressure kN/m2			
1	49.75	0.00	0.00	0.00	0.00	0.00	0.00	7254	
2	49.40	0.00	7.29	2.45	25.08	21.81	21.81	7254	
3	49.14	2.58	11.22	3.78	38.61	33.88	36.46	7254	
4	48.88	5.15	14.92	5.02	51.37	24.93	30.08	7254	
5	48.61	7.73	18.22	6.13	62.72	15.78	23.51	7254	
6	48.35	10.30	21.19	7.13	72.94	7.18	17.48	2917	
7	47.85	15.21	26.26	8.84	90.40	9.52	24.73	2917	
8	47.50	18.64	29.52	9.94	101.62	11.08	29.72	2917	
		18.64	29.52	9.52	107.66	12.81	31.45	8403	
9	47.00	23.54	34.42	11.10	125.52	16.19	39.73	8403	
10	46.50	28.45	39.12	12.62	142.65	19.24	47.69	8403	
11	46.00	33.35	43.68	14.09	159.28	21.79	55.14	8403	
12	45.50	38.26	48.14	15.53	175.57	23.55	61.81	8403	
13	45.00	43.16	52.55	16.95	191.63	24.17	67.33	8403	
		43.16	52.55	18.46	170.92	18.46	61.62a	8627	
14	44.50	48.07	57.41	20.17	186.73	20.17	68.23a	9058	
15	44.17	51.26	60.55	21.27	196.96	21.27	72.53a	9338	
16	43.85	54.45	63.69	22.37	207.17	22.37	76.82a	11942	
17	43.65	56.41	65.62	23.05	213.44	23.05	79.46a	12157	
18	43.18	61.02	70.14	24.64	228.16	24.64	85.66a	12660	
19	43.00	62.78	71.87	25.25	233.79	25.25	88.03a	12853	
20	42.50	67.69	76.69	26.94	249.44	26.94	94.63a	13388	
21	42.00	72.59	81.50	28.63	265.10	28.63	101.22a	13924	
22	41.50	77.50	86.32	30.32	280.78	30.32	107.82a	14459	
23	41.13	81.18	89.94	31.59	292.55	31.59	112.77a	14861	
24	40.75	84.86	93.57	32.87	304.35	32.87	117.72a	15263	

Node no.	Y coord	RIGHT side						Total earth pressure kN/m2	Coeff. of subgrade reaction kN/m3
		Effective stresses							
		Water press. kN/m2	Vertic -al kN/m2	Active limit kN/m2	Passive limit kN/m2	Earth pressure kN/m2			
1	49.75	0.00	0.00	0.00	0.00	0.00	0.00	0.0	
2	49.40	0.00	0.00	0.00	0.00	0.00	0.00	0.0	
3	49.14	0.00	0.00	0.00	0.00	0.00	0.00	0.0	
4	48.88	0.00	0.00	0.00	0.00	0.00	0.00	0.0	
5	48.61	0.00	0.00	0.00	0.00	0.00	0.00	0.0	
6	48.35	0.00	0.00	0.00	0.00	0.00	0.00	0.0	
7	47.85	0.00	0.00	0.00	0.00	0.00	0.00	0.0	
8	47.50	0.00	0.00	0.00	0.00	0.00	0.00	0.0	
9	47.00	0.00	0.00	0.00	0.00	0.00	0.00	0.0	
10	46.50	0.00	0.00	0.00	0.00	0.00	0.00	0.0	
11	46.00	0.00	0.00	0.00	0.00	0.00	0.00	0.0	
12	45.50	0.00	0.00	0.00	0.00	0.00	0.00	0.0	
13	45.00	0.00	0.00	0.00	0.00	0.00	0.00	0.0	
14	44.50	0.00	0.00	0.00	0.00	0.00	0.00	0.0	
15	44.17	0.00	0.00	0.00	0.00	0.00	0.00	0.0	
16	43.85	0.00	0.00	0.00	0.00	0.00	0.00	0.0	
17	43.65	0.00	0.00	0.00	0.00	0.00	0.00	0.0	
		0.00	0.00	0.00	0.00	0.00	0.00	3614	
18	43.18	0.00	8.46	2.85	29.12	9.16	9.16	3614	
		0.00	8.46	2.97	27.52	27.52	27.52p	12660	
19	43.00	0.00	12.06	4.24	39.23	39.23	39.23p	12853	

(continued)

Stage No.10 Change properties of soil type 3 to soil type 4
 Ko pressures will not be reset

Node no.	Y coord	----- RIGHT side -----					Total earth pressure	Coeff. of subgrade reaction
		Water press.	Vertic -al	Effective Active limit	Effective Passive limit	Earth pressure		
		kN/m2	kN/m2	kN/m2	kN/m2	kN/m2	kN/m2	kN/m3
20	42.50	4.90	17.16	6.03	55.80	55.80	60.71p	13388
21	42.00	9.81	22.25	7.82	72.38	72.38	82.19p	13924
22	41.50	14.71	27.35	9.61	88.96	88.96	103.67p	14459
23	41.13	18.39	31.17	10.95	101.40	101.40	119.79p	14861
24	40.75	22.07	35.00	12.29	113.84	113.84	135.91p	15263

Note: 117.72a Soil pressure at active limit
 135.91p Soil pressure at passive limit

Units: kN,m

Stage No.10 Change soil type 3 to soil type 4

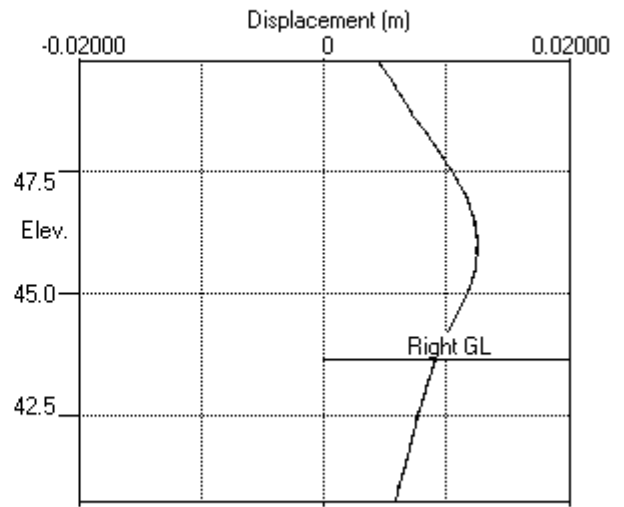
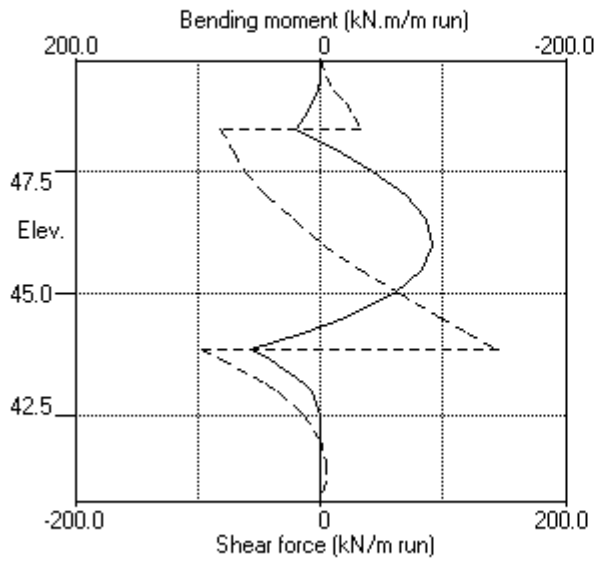

Stage No.10 Change soil type 3 to soil type 4

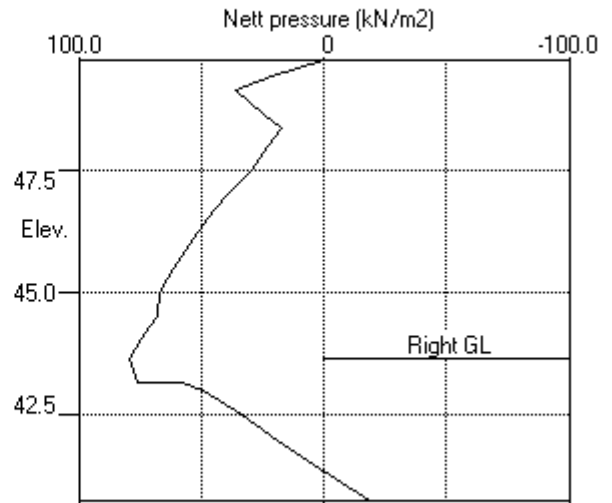
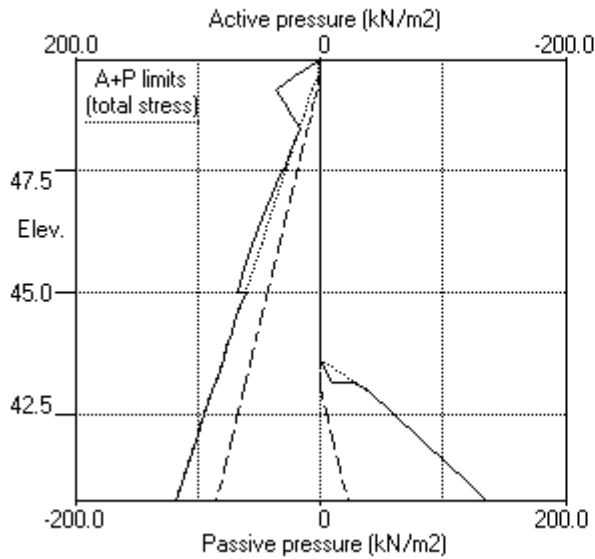

PILEDESIGNS LTD
 Program: WALLAP Version 6.06 Revision A51.B69.R54
 Licensed from GEOSOLVE
 Data filename/Run ID: Hampstead_Wall_1_450mm_rev_01_ULS1
 Hampstead - 24-26 Redington Gardens
 Wall 1, Secant-ULS1, 450 dia @ 650 - run 01

Sheet No.
 Job No. 21495
 Made by : DBS
 Date: 1-10-2018
 Checked :

Units: kN,m

Summary of results

BENDING MOMENT and DISPLACEMENT ANALYSIS of Fully Embedded Wall

Analysis options

Length of wall perpendicular to section = 50.00m
 Subgrade reaction model - Boussinesq Influence coefficients
 Soil deformations are elastic until the active or passive limit is reached
 Open Tension Crack analysis - No

Rigid boundaries: Left side 50.00 from wall
 Right side 50.00 from wall

Limit State: ULS DA1 Combination 1

Calculated Bending Moments and Strut Forces have been multiplied by a factor of 1.35 to obtain values for structural design.

Bending moment, shear force and displacement envelopes

Node no.	Y coord	Displacement		Bending moment				Shear force			
		max. m	min. m	Calculated kN.m/m		Factored kN.m/m		Calculated kN/m		Factored kN/m	
1	49.75	0.012	0.000	0	-0	0	-0	0	0	0	0
2	49.40	0.011	0.000	1	0	1	0	4	-1	6	-1
3	49.14	0.010	0.000	2	-0	3	-0	13	-2	17	-2
4	48.88	0.009	0.000	7	-1	10	-1	22	-2	30	-3
5	48.61	0.009	0.000	14	-2	19	-2	29	-2	40	-3
6	48.35	0.008	0.000	22	-2	30	-3	35	-92	47	-124
7	47.85	0.010	0.000	13	-22	17	-29	21	-82	29	-110
8	47.50	0.011	0.000	21	-49	29	-66	27	-72	36	-98
9	47.00	0.012	0.000	35	-81	47	-110	26	-57	35	-77
10	46.50	0.013	0.000	46	-105	62	-142	17	-38	23	-51
11	46.00	0.013	0.000	52	-117	70	-158	4	-16	5	-21
12	45.50	0.013	0.000	49	-119	66	-161	33	-11	44	-15
13	45.00	0.013	0.000	41	-108	56	-145	65	-18	88	-24
14	44.50	0.011	0.000	31	-86	42	-116	98	-20	132	-27
15	44.17	0.010	0.000	25	-68	34	-91	120	-19	163	-26
16	43.85	0.009	0.000	57	-47	78	-63	145	-96	195	-130
17	43.65	0.009	0.000	41	-32	55	-43	77	-81	103	-109
18	43.18	0.008	0.000	17	0	23	0	92	-44	124	-59
19	43.00	0.008	0.000	29	0	39	0	71	-34	96	-47
20	42.50	0.008	0.000	47	-0	64	-0	16	-14	21	-19
21	42.00	0.007	0.000	47	0	63	0	0	-30	0	-41
22	41.50	0.007	0.000	25	-0	34	-0	5	-43	7	-57
23	41.13	0.006	0.000	9	-0	13	-0	5	-34	6	-45
24	40.75	0.006	0.000	0	-0	0	-0	0	0	0	0

Summary of results (continued)

Calculated Bending Moments and Strut Forces have been multiplied by a factor of 1.35 to obtain values for structural design.

Maximum and minimum bending moment and shear force at each stage

Stage no.	Bending moment				Shear force						
	Calculated		Factored		Calculated		Factored				
min.	max. elev.	min. elev.	max. elev.	max. min.	max. min.	max. elev.	min. elev.	max. min.			
	kN.m/m	kN.m/m	kN.m/m	kN/m	kN/m	kN/m	kN/m	kN/m			
1	43.65	-3	46.50	2	-4	3	45.00	-1	47.85	4	
-2	44.17	-2	47.85	5	-3	4	47.50	-2	48.88	5	
-3	52	46.00	-0	41.13	70	-0	27	47.50	-20	44.50	36
-27	No calculation at this stage										
4	44	46.00	-0	49.75	59	-0	22	47.50	-15	44.17	29
-21	46	42.00	-118	45.50	62	-159	90	43.18	-92	48.35	121
-124	47	42.50	-119	45.50	63	-161	92	43.18	-92	48.35	124
-124	No calculation at this stage										
8	47	42.50	-106	45.50	64	-143	75	43.85	-86	48.35	101
-117	57	43.85	-91	46.00	78	-122	145	43.85	-96	43.85	195
-130	No calculation at this stage										
11	38	43.85	-96	46.00	51	-129	137	43.85	-83	48.35	186
-113											

Maximum and minimum displacement at each stage

Stage no.	Displacement				Stage description
	maximum	elev.	minimum	elev.	
	m		m		
1	0.001	47.85	0.000	49.75	Apply surcharge no.1 at elev. 49.75
2	0.001	49.75	0.000	49.75	Apply water pressure profile no.1
3	0.012	49.75	0.000	49.75	Excav. to elev. 47.85 on RIGHT side
4	No calculation at this stage				Install strut no.1 at elev. 48.35
5	0.012	49.75	0.000	49.75	Apply water pressure profile no.2
6	0.013	46.00	0.000	49.75	Excav. to elev. 43.18 on RIGHT side
7	0.013	46.00	0.000	49.75	Fill to elev. 43.65 on RIGHT side
8	No calculation at this stage				Install strut no.2 at elev. 43.85
9	0.013	46.00	0.000	49.75	Change EI of wall to 43355kN.m ² /m run
10	0.013	46.00	0.000	49.75	Change soil type 3 to soil type 4
11	No calculation at this stage				Apply surcharge no.2 at elev. 43.65
12	0.013	46.00	0.000	49.75	Apply water pressure profile no.3

Strut forces at each stage (horizontal components)

Stage no.	Strut no. 1			Strut no. 2		
	at elev. 48.35			at elev. 43.85		
	Calculated	Factored	Calculated	Factored	Calculated	Factored
	kN per m run	kN per strut	kN per strut	kN per m run	kN per strut	kN per strut
5	6	6	8	---	---	---
6	125	125	169	---	---	---
7	126	126	169	---	---	---
9	121	121	164	25	25	34
10	114	114	155	241	241	325
12	117	117	158	191	191	257

Units: kN,m

Bending moment, shear force, displacement envelopes

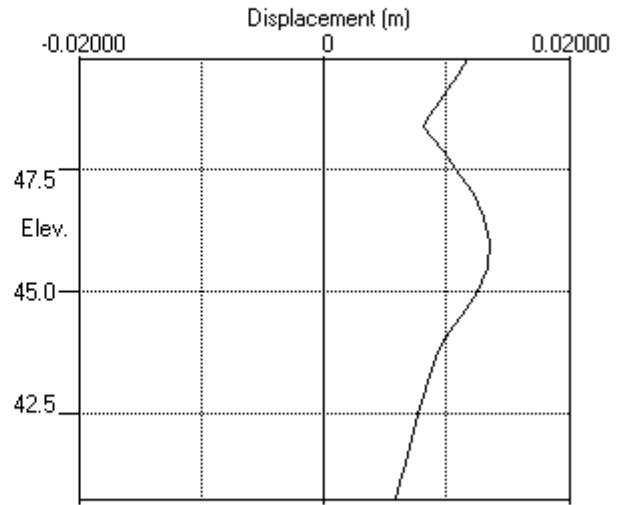
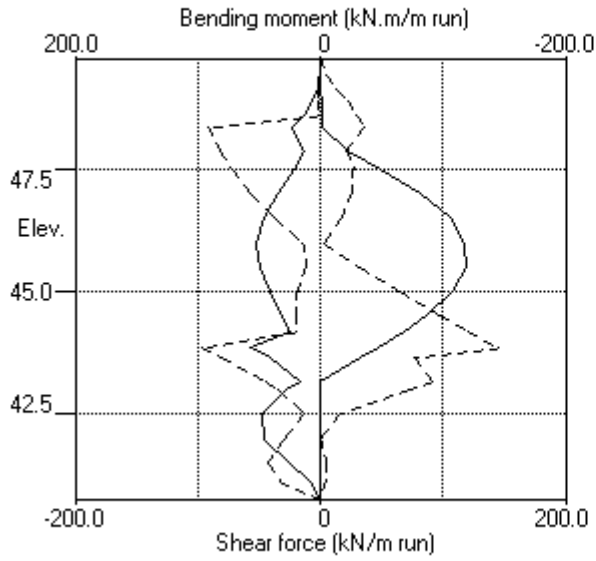



WALLAP

1-ULS2

PILEDESIGNS LTD
 Program: WALLAP Version 6.06 Revision A51.B69.R54
 Licensed from GEOSOLVE
 Data filename/Run ID: Hampstead_Wall_1_450mm_rev_01_ULS2
 Hampstead - 24-26 Redington Gardens
 Wall 1, Secant-ULS2, 450 dia @ 650 - run 01

Sheet No.
 Job No. 21495
 Made by : DBS
 Date: 1-10-2018
 Checked :

Units: kN,m

INPUT DATA

SOIL PROFILE

Stratum no.	Elevation of top of stratum	Soil types	
		Left side	Right side
1	49.75	1 Made Ground dr	1 Made Ground dr
2	47.50	2 Claygate Clay dr	2 Claygate Clay dr
3	45.00	3 London Clay und	3 London Clay und

SOIL PROPERTIES (Unfactored SLS soil strengths)

-- Soil type --	Bulk density	Young's Modulus	At rest coeff.	Consol state.	Active limit	Passive limit	Cohesion
No. Description (Datum elev.)	kN/m3	Eh,kN/m2 (dEh/dy)	Ko (dKo/dy)	NC/OC (Nu)	Ka (Kac)	Kp (Kpc)	kN/m2 (dc/dy)
1 Made Ground dr	18.00	10000	0.530	OC (0.250)	0.337 (0.000)	3.442 (0.000)	
2 Claygate Clay dr	19.00	30000	1.000	NC (0.200)	0.323 (1.330)	3.647 (5.195)	0.0d
3 London Cl.. (45.00)	20.00	40000 (4000)	1.000	OC (0.490)	1.000 (2.476)	1.000 (2.390)	50.00u (5.000)
4 London Cl.. (45.00)	20.00	30800 (3080)	1.000	OC (0.200)	0.351 (1.391)	3.253 (4.831)	0.0d

Additional soil parameters associated with Ka and Kp

No. Description	--- parameters for Ka ---			--- parameters for Kp ---		
	Soil friction angle	Wall adhesion coeff.	Back-fill angle	Soil friction angle	Wall adhesion coeff.	Back-fill angle
1 Made Ground dr	26.00	0.670	0.00	26.00	0.500	0.00
2 Claygate Clay dr	27.00	0.670	0.00	27.00	0.500	0.00
3 London Clay und	0.00	0.670	0.00	0.00	0.500	0.00
4 London Clay dr	25.00	0.670	0.00	25.00	0.500	0.00

GROUND WATER CONDITIONS

Density of water = 9.810 kN/m3

	Left side	Right side
Initial water table elevation	49.40	49.40

Automatic water pressure balancing at toe of wall : No

Water profile no.	Left side			Right side		
	Point no.	Elev. m	Piezo elev. m	Point no.	Elev. m	Piezo elev. m
1	1	49.40	49.40	1	47.50	47.50
2	1	49.40	49.40	1	43.00	43.00
3	1	49.40	49.40	1	43.65	43.65
				2	43.65	49.40

WALL PROPERTIES

Type of structure = Fully Embedded Wall
 Elevation of toe of wall = 40.75
 Maximum finite element length = 0.50 m
 Youngs modulus of wall E = 1.9600E+07 kN/m2
 Moment of inertia of wall I = 3.0968E-03 m4/m run
 E.I = 60696 kN.m2/m run
 Yield Moment of wall = Not defined

STRUTS and ANCHORS

Strut/ anchor no.	Elev.	Strut spacing m	X-section area of strut sq.m	Youngs modulus kN/m2	Free length m	Inclin -ation (degs)	Pre- stress /strut kN	Tension allowed
1	48.35	1.00	0.400000	1.400E+07	5.00	0.00	0	No
2	43.85	1.00	0.300000	1.400E+07	5.00	0.00	0	No

SURCHARGE LOADS

Surch -arge no.	Elev.	Distance from wall	Length parallel to wall	Width perpend. to wall	Surcharge ----- Near edge	Surcharge ----- Far edge	Equiv. soil type	Partial factor/ Category
1	49.75	0.50(L)	10.00	10.00	10.00	=	N/A	1.30 Var
2	43.65	-0.00(R)	10.00	10.00	57.00	=	N/A	1.00 P/F

Note: L = Left side, R = Right side

Limit State Categories P/U = Permanent Unfavourable
P/F = Permanent Favourable
Var = Variable (unfavourable)

CONSTRUCTION STAGES

Construction stage no.	Stage description
1	Apply surcharge no.1 at elevation 49.75
2	Apply water pressure profile no.1 (Worst Cred.)
3	Excavate to elevation 47.85 on RIGHT side
4	Install strut or anchor no.1 at elevation 48.35
5	Apply water pressure profile no.2 (Worst Cred.)
6	Excavate to elevation 43.18 on RIGHT side
7	Fill to elevation 43.65 on RIGHT side with soil type 1
8	Install strut or anchor no.2 at elevation 43.85
9	Change EI of wall to 43355 kN.m2/m run Yield moment not defined Allow wall to relax with new modulus value
10	Change properties of soil type 3 to soil type 4 Ko pressures will not be reset
11	Apply surcharge no.2 at elevation 43.65 No analysis at this stage
12	Apply water pressure profile no.3 (Worst Cred.)

FACTORS OF SAFETY and ANALYSIS OPTIONS

Limit State options: ULS DA1 Combination 2

Water pressures : Worst Credible

Partial factor on C' = 1.250

Partial factor on Phi' = 1.250

Partial factor on Cu = 1.400

Partial factor on Soil Modulus = 1.000

Partial factor on Permanent Unfavourable loads = 1.000

Partial factor on Permanent Favourable loads = 1.000

Partial factor on Variable Unfavourable loads = 1.300

Stability analysis:

Method of analysis - Strength Factor method

Overall factor on soil strength for calculating wall depth = 1.00

Parameters for undrained strata:

Minimum equivalent fluid density = 5.00 kN/m3

Maximum depth of water filled tension crack = 0.00 m

Bending moment and displacement calculation:

Method - Subgrade reaction model using Influence Coefficients

Open Tension Crack analysis? - No

Non-linear Modulus Parameter (L) = 9.000 m

Boundary conditions:

Length of wall (normal to plane of analysis) = 50.00 m

Width of excavation on Left side of wall = 50.00 m

Width of excavation on Right side of wall = 50.00 m

Distance to rigid boundary on Left side = 50.00 m

Distance to rigid boundary on Right side = 50.00 m

OUTPUT OPTIONS

Stage no.	Stage description	Displacement	Active, Passive pressures	Graph. output
1	Apply surcharge no.1 at elev. 49.75	No	No	No
2	Apply water pressure profile no.1	Yes	Yes	Yes
3	Excav. to elev. 47.85 on RIGHT side	Yes	Yes	Yes
4	Install strut no.1 at elev. 48.35	Yes	Yes	Yes
5	Apply water pressure profile no.2	Yes	Yes	Yes
6	Excav. to elev. 43.18 on RIGHT side	Yes	Yes	Yes
7	Fill to elev. 43.65 on RIGHT side	Yes	Yes	Yes
8	Install strut no.2 at elev. 43.85	Yes	Yes	Yes
9	Change EI of wall to 43355kN.m ² /m run	No	No	No
10	Change soil type 3 to soil type 4	No	No	No
11	Apply surcharge no.2 at elev. 43.65	No	No	No
12	Apply water pressure profile no.3	No	No	No
*	Summary output	Yes	-	Yes

Program WALLAP - Copyright (C) 2017 by DL Borin, distributed by GEOSOLVE
150 St. Alphonsus Road, London SW4 7BW, UK www.geosolve.co.uk

Units: kN,m

Stage No.12 Apply water pressure profile no.3 (Worst Cred.)

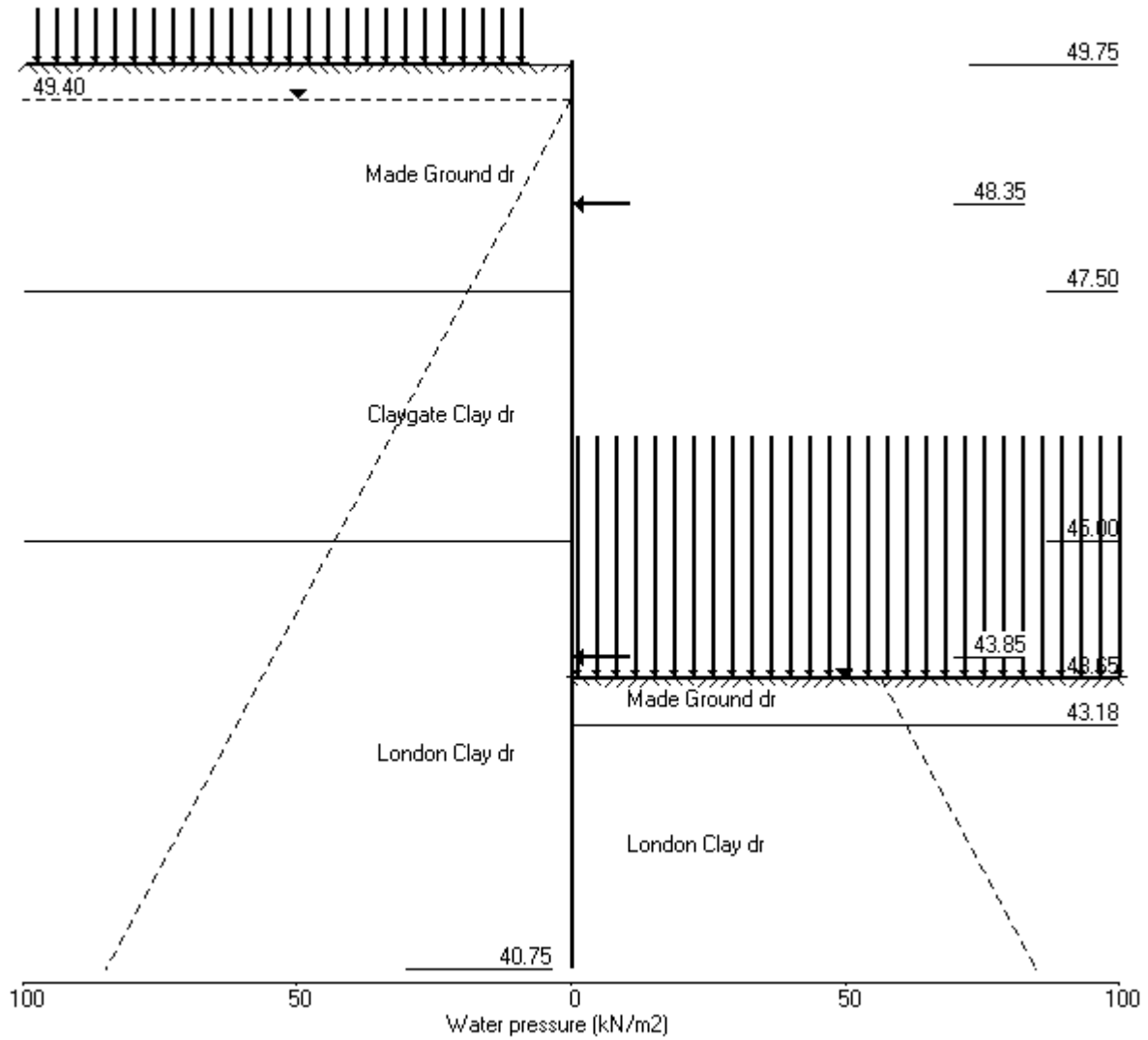

PILEDESIGNS LTD
 Program: WALLAP Version 6.06 Revision A51.B69.R54
 Licensed from GEOSOLVE
 Data filename/Run ID: Hampstead_Wall_1_450mm_rev_01_ULS2
 Hampstead - 24-26 Redington Gardens
 Wall 1, Secant-ULS2, 450 dia @ 650 - run 01

Sheet No.
 Job No. 21495
 Made by : DBS
 Date: 1-10-2018
 Checked :

Units: kN,m

Stage No. 3 Excavate to elevation 47.85 on RIGHT side

STABILITY ANALYSIS of Fully Embedded Wall according to Strength Factor method
 Factor of safety on soil strength

			Overall					
			FoS for toe		Toe elev. for			
			elev. = 40.75		FoS = 1.000			

Stage No.	--- G.L. Act.	--- Pass.	Strut Elev.	Factor of Safety	Moment of equil. at elev.	Toe elev.	Wall Penetr-ation	Direction of failure
3	49.75	47.85	Cant.	1.667	41.78	43.10	4.75	L to R

BENDING MOMENT and DISPLACEMENT ANALYSIS of Fully Embedded Wall

Analysis options

Length of wall perpendicular to section = 50.00m

Subgrade reaction model - Boussinesq Influence coefficients

Soil deformations are elastic until the active or passive limit is reached

Open Tension Crack analysis - No

Rigid boundaries: Left side 50.00 from wall
 Right side 50.00 from wall

Limit State: ULS DA1 Combination 2

Node no.	Y coord	Nett pressure kN/m2	Wall disp. m	Wall rotation rad.	Shear force kN/m	Bending moment kN.m/m	Strut forces kN/m	EI of wall kN.m2/m
1	49.75	0.00	0.023	5.05E-03	0.0	0.0		60696
2	49.40	3.06	0.022	5.05E-03	0.5	0.2		60696
3	49.14	7.38	0.020	5.05E-03	1.9	0.5		60696
4	48.88	11.59	0.019	5.04E-03	4.4	1.3		60696
5	48.61	15.61	0.018	5.04E-03	8.0	2.9		60696
6	48.35	19.46	0.016	5.02E-03	12.6	5.5		60696
7	47.85	26.52	0.014	4.93E-03	24.1	14.6		60696
8	47.50	14.54	0.012	4.82E-03	31.3	24.4		60696
		13.31	0.012	4.82E-03	31.3	24.4		
9	47.00	2.45	0.010	4.55E-03	35.2	41.1		60696
10	46.50	-8.49	0.008	4.14E-03	33.7	58.4		60696
11	46.00	-19.50	0.006	3.60E-03	26.7	73.7		60696
12	45.50	-30.56	0.004	2.95E-03	14.2	84.0		60696
13	45.00	-33.88	0.003	2.24E-03	-1.9	87.9		60696
		-66.57	0.003	2.24E-03	-1.9	87.9		
14	44.50	-31.05	0.002	1.55E-03	-26.3	78.6		60696
15	44.17	-13.91	0.001	1.16E-03	-33.6	68.4		60696
16	43.85	-1.20	0.001	8.30E-04	-36.1	56.8		60696
17	43.65	4.63	0.001	6.55E-04	-35.8	49.5		60696
18	43.18	13.29	0.001	3.35E-04	-31.6	33.2		60696
19	43.00	15.05	0.001	2.44E-04	-29.0	27.7		60696
20	42.50	16.71	0.001	6.82E-05	-21.1	15.1		60696
21	42.00	15.09	0.001	-2.13E-05	-13.1	6.7		60696
22	41.50	11.70	0.001	-5.68E-05	-6.4	2.0		60696
23	41.13	8.60	0.001	-6.41E-05	-2.6	0.4		60696
24	40.75	5.32	0.001	-6.53E-05	0.0	0.0		---

(continued)

Stage No.3 Excavate to elevation 47.85 on RIGHT side

Node no.	Y coord	----- LEFT side -----					Total earth pressure kN/m2	Coeff. of subgrade reaction kN/m3
		Water press. kN/m2	Vertic -al kN/m2	Effective Active limit kN/m2	Effective Passive limit kN/m2	Earth pressure kN/m2		
1	49.75	0.00	0.00	0.00	0.00	0.00	0.00	3349
2	49.40	0.00	7.46	3.06	19.88	3.06	3.06a	3349
3	49.14	2.58	11.72	4.81	31.22	4.81	7.38a	3349
4	48.88	5.15	15.71	6.44	41.85	6.44	11.59a	3349
5	48.61	7.73	19.22	7.88	51.19	7.88	15.61a	3349
6	48.35	10.30	22.33	9.16	59.49	9.16	19.46a	3349
7	47.85	15.21	27.58	11.31	73.47	11.31	26.52a	3349
8	47.50	18.64	30.91	12.68	82.35	12.68	31.32a	3349
		18.64	30.91	12.23	86.18	12.23	30.87a	9661
9	47.00	23.54	35.87	14.19	100.00	14.19	37.73a	9661
10	46.50	28.45	40.58	16.06	113.14	16.06	44.50a	9661
11	46.00	33.35	45.14	17.86	125.83	17.86	51.21a	9661
12	45.50	38.26	49.58	19.62	138.22	19.62	57.87a	9661
13	45.00	43.16	53.95	21.34	150.40	29.11	72.27	9661
		Total>	97.11	23.75m	182.48	48.20	48.20	18739
14	44.50	Total>	106.84	26.25m	196.47	73.72	73.72	19676
15	44.17	Total>	113.14	27.88m	205.55	87.68	87.68	20285
16	43.85	Total>	119.43	29.50m	214.62	99.69	99.69	20894
17	43.65	Total>	123.30	30.50m	220.20	106.21	106.21	21268
18	43.18	Total>	132.39	32.85m	233.30	119.31	119.31	22149
19	43.00	Total>	135.87	33.75m	238.31	123.64	123.64	22486
20	42.50	Total>	145.53	36.25m	252.25	134.25	134.25	23423
21	42.00	Total>	155.20	40.21	266.18	143.41	143.41	24360
22	41.50	Total>	164.88	45.47	280.13	151.80	151.80	25297
23	41.13	Total>	172.14	49.41	290.59	157.84	157.84	26000
24	40.75	Total>	177.09	51.04	298.74	163.81	163.81	26703

Node no.	Y coord	----- RIGHT side -----					Total earth pressure kN/m2	Coeff. of subgrade reaction kN/m3
		Water press. kN/m2	Vertic -al kN/m2	Effective Active limit kN/m2	Effective Passive limit kN/m2	Earth pressure kN/m2		
1	49.75	0.00	0.00	0.00	0.00	0.00	0.00	0.0
2	49.40	0.00	0.00	0.00	0.00	0.00	0.00	0.0
3	49.14	0.00	0.00	0.00	0.00	0.00	0.00	0.0
4	48.88	0.00	0.00	0.00	0.00	0.00	0.00	0.0
5	48.61	0.00	0.00	0.00	0.00	0.00	0.00	0.0
6	48.35	0.00	0.00	0.00	0.00	0.00	0.00	0.0
7	47.85	0.00	0.00	0.00	0.00	0.00	0.00	0.0
		0.00	0.00	0.00	0.00	0.00	0.00	4405
8	47.50	0.00	6.30	2.58	16.78	16.78	16.78p	4405
		0.00	6.30	2.49	17.56	17.56	17.56p	12733
9	47.00	4.90	10.90	4.31	30.37	30.37	35.28p	12733
10	46.50	9.81	15.49	6.13	43.19	43.19	53.00p	12733
11	46.00	14.71	20.09	7.95	56.00	56.00	70.71p	12733
12	45.50	19.62	24.68	9.77	68.81	68.81	88.43p	12733
13	45.00	24.52	29.28	11.58	81.62	81.62	106.15p	12733
		Total>	53.80	14.25m	139.16	114.78	114.78	24214
14	44.50	Total>	63.80	16.75m	153.44	104.76	104.76	25424
15	44.17	Total>	70.31	18.37m	162.71	101.59	101.59	26211
16	43.85	Total>	76.81	20.00m	171.99	100.90	100.90	26998
17	43.65	Total>	80.81	21.00m	177.70	101.58	101.58	27482
18	43.18	Total>	90.21	23.35m	191.11	106.02	106.02	28620
19	43.00	Total>	93.81	24.25m	196.25	108.59	108.59	29056

(continued)

Stage No.3 Excavate to elevation 47.85 on RIGHT side

Node no.	Y coord	----- RIGHT side -----					Total earth pressure kN/m2	Coeff. of subgrade reaction kN/m3
		Water press. kN/m2	Vertic -al kN/m2	Effective Active limit kN/m2	Effective Passive limit kN/m2	Earth pressure kN/m2		
20	42.50	Total>	103.82	26.75m	210.52	117.54	117.54	30267
21	42.00	Total>	113.82	29.25m	224.80	128.32	128.32	31478
22	41.50	Total>	123.83	31.75m	239.07	140.10	140.10	32688
23	41.13	Total>	131.33	33.62m	249.78	149.24	149.24	33596
24	40.75	Total>	138.84	35.50m	260.49	158.49	158.49	34504

Note: 57.87a Soil pressure at active limit
106.15p Soil pressure at passive limit

Units: kN,m

Stage No.3 Excav. to elev. 47.85 on RIGHT side

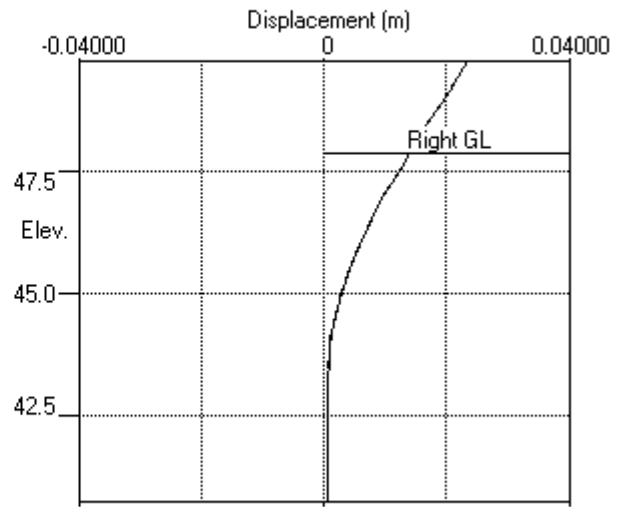
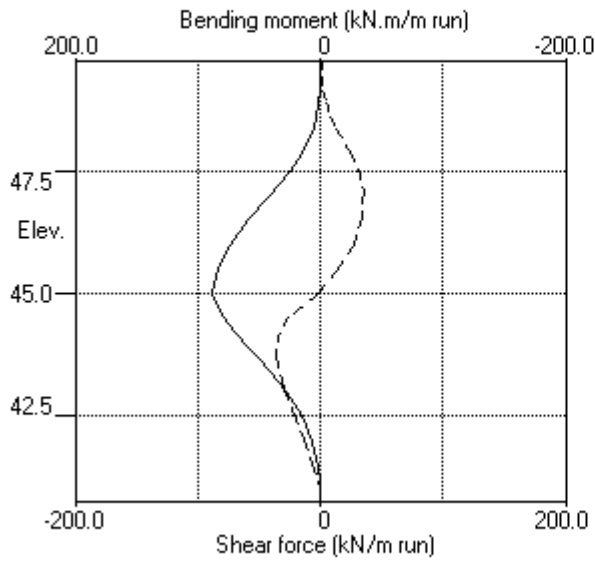

Stage No.3 Excav. to elev. 47.85 on RIGHT side

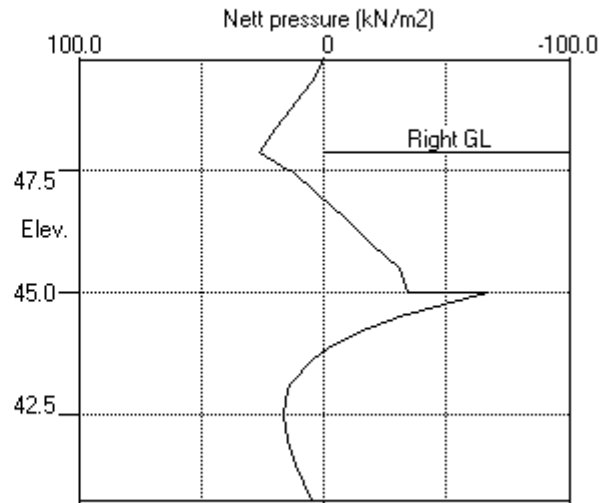
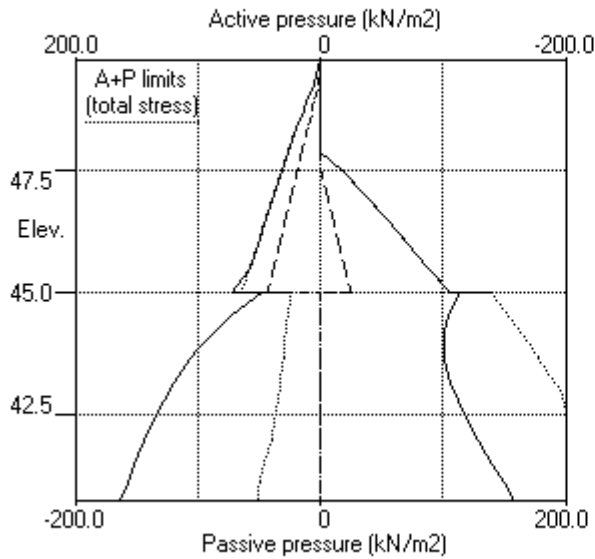

PILEDESIGNS LTD
 Program: WALLAP Version 6.06 Revision A51.B69.R54
 Licensed from GEOSOLVE
 Data filename/Run ID: Hampstead_Wall_1_450mm_rev_01_ULS2
 Hampstead - 24-26 Redington Gardens
 Wall 1, Secant-ULS2, 450 dia @ 650 - run 01

Sheet No.
 Job No. 21495
 Made by : DBS
 Date: 1-10-2018
 Checked :

Units: kN,m

Stage No. 6 Excavate to elevation 43.18 on RIGHT side

STABILITY ANALYSIS of Fully Embedded Wall according to Strength Factor method
 Factor of safety on soil strength

			Overall						
			FoS for toe	Toe elev. for					
			elev. = 40.75	FoS = 1.000					

Stage No.	--- G.L. Act.	--- Pass.	Strut Elev.	Factor of Safety	Moment of equil. at elev.	Toe elev.	Wall Penetr-ation	Direction of failure	
6	49.75	43.18	48.35	1.326	n/a	42.12	1.06	L to R	

BENDING MOMENT and DISPLACEMENT ANALYSIS of Fully Embedded Wall

Analysis options

Length of wall perpendicular to section = 50.00m

Subgrade reaction model - Boussinesq Influence coefficients

Soil deformations are elastic until the active or passive limit is reached

Open Tension Crack analysis - No

Rigid boundaries: Left side 50.00 from wall

Right side 50.00 from wall

Limit State: ULS DA1 Combination 2

Node no.	Y coord	Nett pressure kN/m2	Wall disp. m	Wall rotation rad.	Shear force kN/m	Bending moment kN.m/m	Strut forces kN/m	EI of wall kN.m2/m
1	49.75	0.00	0.013	-2.39E-03	0.0	0.0		60696
2	49.40	19.88	0.014	-2.39E-03	3.5	0.5		60696
3	49.14	33.80	0.015	-2.39E-03	10.5	2.2		60696
4	48.88	39.42	0.015	-2.41E-03	20.1	5.9		60696
5	48.61	29.11	0.016	-2.45E-03	29.1	12.6		60696
6	48.35	19.46	0.017	-2.52E-03	35.5	21.3	138.3	60696
		19.46	0.017	-2.52E-03	-102.8	21.3		
7	47.85	26.52	0.018	-2.50E-03	-91.3	-27.3		60696
8	47.50	31.32	0.019	-2.25E-03	-81.1	-57.5		60696
		30.87	0.019	-2.25E-03	-81.1	-57.5		
9	47.00	37.73	0.020	-1.63E-03	-64.0	-94.0		60696
10	46.50	44.50	0.020	-7.49E-04	-43.4	-121.1		60696
11	46.00	51.21	0.020	3.13E-04	-19.5	-137.0		60696
12	45.50	57.87	0.020	1.45E-03	7.8	-140.2		60696
13	45.00	64.51	0.019	2.56E-03	38.4	-127.9		60696
		23.75	0.019	2.56E-03	38.4	-127.9		
14	44.50	26.25	0.017	3.52E-03	50.9	-107.2		60696
15	44.17	27.88	0.016	4.05E-03	59.7	-89.6		60696
16	43.85	29.50	0.015	4.48E-03	69.0	-69.0		60696
17	43.65	30.50	0.014	4.68E-03	75.0	-54.6		60696
18	43.18	32.85	0.012	4.95E-03	89.9	-16.3		60696
		-68.04	0.012	4.95E-03	89.9	-16.3		
19	43.00	-72.28	0.011	4.98E-03	77.2	-1.3		60696
20	42.50	-84.05	0.008	4.87E-03	38.2	27.7		60696
21	42.00	-81.27	0.006	4.59E-03	-3.2	40.1		60696
22	41.50	-50.60	0.004	4.31E-03	-36.1	28.2		60696
23	41.13	17.18	0.002	4.18E-03	-42.4	13.4		60696
24	40.75	209.02	0.000	4.14E-03	0.0	-0.0		---

At elev. 48.35 Strut force = 138.3 kN/strut = 138.3 kN/m run

(continued)

Stage No.6 Excavate to elevation 43.18 on RIGHT side

Node no.	Y coord	----- LEFT side -----					Total earth pressure kN/m2	Coeff. of subgrade reaction kN/m3
		Water press. kN/m2	Vertic -al kN/m2	Effective Active limit kN/m2	Effective Passive limit kN/m2	Earth pressure kN/m2		
1	49.75	0.00	0.00	0.00	0.00	0.00	7294	
2	49.40	0.00	7.46	3.06	19.88	19.88	7294	
3	49.14	2.58	11.72	4.81	31.22	31.22	7294	
4	48.88	5.15	15.71	6.44	41.85	34.27	7294	
5	48.61	7.73	19.22	7.88	51.19	21.38	7294	
6	48.35	10.30	22.33	9.16	59.49	9.16	2265	
7	47.85	15.21	27.58	11.31	73.47	11.31	2265	
8	47.50	18.64	30.91	12.68	82.35	12.68	2265	
		18.64	30.91	12.23	86.18	12.23	6505	
9	47.00	23.54	35.87	14.19	100.00	14.19	6505	
10	46.50	28.45	40.58	16.06	113.14	16.06	6505	
11	46.00	33.35	45.14	17.86	125.83	17.86	6505	
12	45.50	38.26	49.58	19.62	138.22	19.62	6505	
13	45.00	43.16	53.95	21.34	150.40	21.34	6505	
		Total>	97.11	23.75m	182.48	23.75	13192	
14	44.50	Total>	106.84	26.25m	196.47	26.25	13851	
15	44.17	Total>	113.14	27.88m	205.55	27.88	14280	
16	43.85	Total>	119.43	29.50m	214.62	29.50	14709	
17	43.65	Total>	123.30	30.50m	220.20	30.50	14972	
18	43.18	Total>	132.39	32.85m	233.30	32.85	15592	
19	43.00	Total>	135.87	33.75m	238.31	33.75	15830	
20	42.50	Total>	145.53	36.25m	252.25	36.25	16490	
21	42.00	Total>	155.20	40.21	266.18	53.29	17149	
22	41.50	Total>	164.88	45.47	280.13	98.23	17809	
23	41.13	Total>	172.14	49.41	290.59	132.37	18303	
24	40.75	Total>	177.09	51.04	298.74	221.17	294218	

Node no.	Y coord	----- RIGHT side -----					Total earth pressure kN/m2	Coeff. of subgrade reaction kN/m3
		Water press. kN/m2	Vertic -al kN/m2	Effective Active limit kN/m2	Effective Passive limit kN/m2	Earth pressure kN/m2		
1	49.75	0.00	0.00	0.00	0.00	0.00	0.0	
2	49.40	0.00	0.00	0.00	0.00	0.00	0.0	
3	49.14	0.00	0.00	0.00	0.00	0.00	0.0	
4	48.88	0.00	0.00	0.00	0.00	0.00	0.0	
5	48.61	0.00	0.00	0.00	0.00	0.00	0.0	
6	48.35	0.00	0.00	0.00	0.00	0.00	0.0	
7	47.85	0.00	0.00	0.00	0.00	0.00	0.0	
8	47.50	0.00	0.00	0.00	0.00	0.00	0.0	
9	47.00	0.00	0.00	0.00	0.00	0.00	0.0	
10	46.50	0.00	0.00	0.00	0.00	0.00	0.0	
11	46.00	0.00	0.00	0.00	0.00	0.00	0.0	
12	45.50	0.00	0.00	0.00	0.00	0.00	0.0	
13	45.00	0.00	0.00	0.00	0.00	0.00	0.0	
14	44.50	0.00	0.00	0.00	0.00	0.00	0.0	
15	44.17	0.00	0.00	0.00	0.00	0.00	0.0	
16	43.85	0.00	0.00	0.00	0.00	0.00	0.0	
17	43.65	0.00	0.00	0.00	0.00	0.00	0.0	
18	43.18	0.00	0.00	0.00	0.00	0.00	0.0	
		Total>	0.00	0.00	100.89	100.89p	33434	
19	43.00	Total>	3.60	0.90m	106.03	106.03p	33943	
20	42.50	Total>	13.60	3.40m	120.30	120.30p	35358	
21	42.00	Total>	23.60	5.90m	134.57	134.57p	36772	

(continued)

Stage No.6 Excavate to elevation 43.18 on RIGHT side

Node no.	Y coord	----- RIGHT side -----					Total earth pressure	Coeff. of subgrade reaction
		Water press. kN/m2	Vertical kN/m2	Effective Active limit kN/m2	Effective Passive limit kN/m2	Earth pressure kN/m2		
22	41.50	Total>	33.60	8.40m	148.84	148.84	148.84p	38186
23	41.13	Total>	41.10	10.27m	159.54	115.19	115.19	39247
24	40.75	Total>	48.61	12.15m	170.24	12.15	12.15a	550656

Note: 12.15a Soil pressure at active limit
 148.84p Soil pressure at passive limit

Units: kN,m

Stage No.6 Excav. to elev. 43.18 on RIGHT side

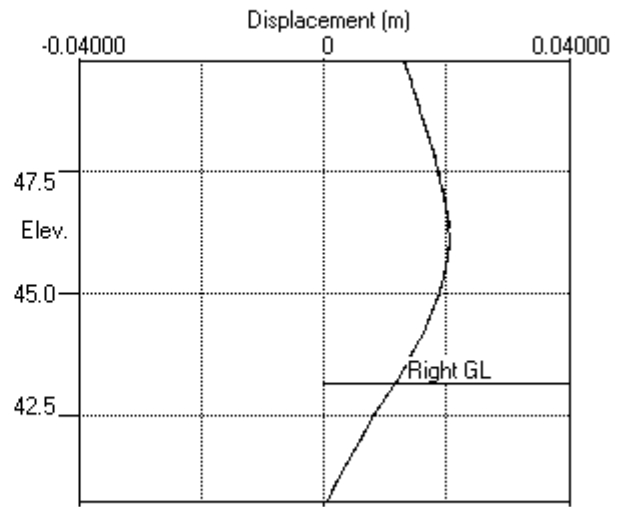
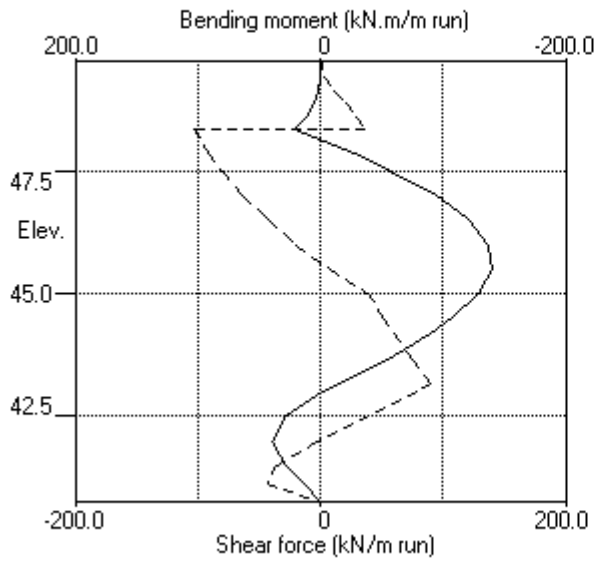

Stage No.6 Excav. to elev. 43.18 on RIGHT side

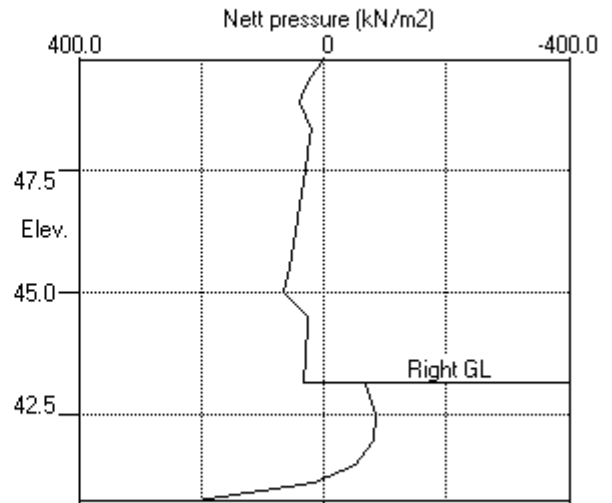
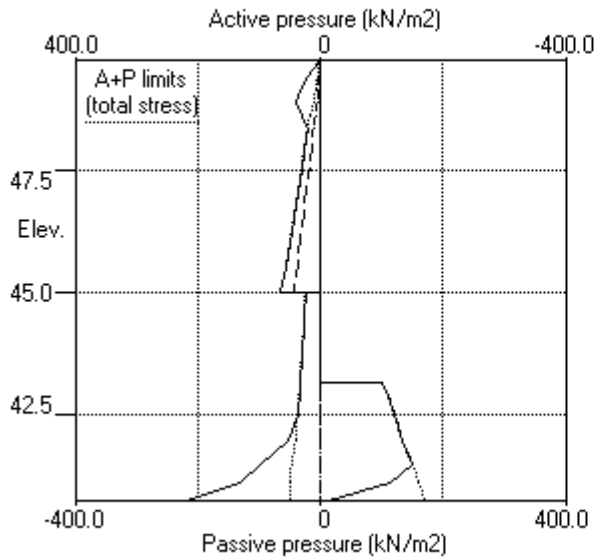

PILEDESIGNS LTD
 Program: WALLAP Version 6.06 Revision A51.B69.R54
 Licensed from GEOSOLVE
 Data filename/Run ID: Hampstead_Wall_1_450mm_rev_01_ULS2
 Hampstead - 24-26 Redington Gardens
 Wall 1, Secant-ULS2, 450 dia @ 650 - run 01

Sheet No.
 Job No. 21495
 Made by : DBS
 Date: 1-10-2018
 Checked :

Units: kN,m

Stage No. 7 Fill to elevation 43.65 on RIGHT side with soil type 1

STABILITY ANALYSIS of Fully Embedded Wall according to Strength Factor method
 Factor of safety on soil strength

			Overall							
			FoS for toe	Toe elev. for						
			elev. = 40.75	FoS = 1.000						

Stage No.	--- G.L. Act.	--- Pass.	Strut Elev.	Factor of Safety	Moment of equil. at elev.	Toe elev.	Wall Penetr-ation	Direction of failure		
7	49.75	43.65	48.35	1.390	n/a	42.25	1.40	L to R		

BENDING MOMENT and DISPLACEMENT ANALYSIS of Fully Embedded Wall

Analysis options

Length of wall perpendicular to section = 50.00m

Subgrade reaction model - Boussinesq Influence coefficients

Soil deformations are elastic until the active or passive limit is reached

Open Tension Crack analysis - No

Rigid boundaries: Left side 50.00 from wall

Right side 50.00 from wall

Limit State: ULS DA1 Combination 2

Node no.	Y coord	Nett pressure kN/m2	Wall disp. m	Wall rotation rad.	Shear force kN/m	Bending moment kN.m/m	Strut forces kN/m	EI of wall kN.m2/m
1	49.75	0.00	0.013	-2.39E-03	0.0	0.0		60696
2	49.40	19.88	0.014	-2.39E-03	3.5	0.5		60696
3	49.14	33.79	0.015	-2.39E-03	10.5	2.2		60696
4	48.88	39.41	0.015	-2.41E-03	20.1	5.9		60696
5	48.61	29.11	0.016	-2.45E-03	29.1	12.6		60696
6	48.35	19.46	0.017	-2.52E-03	35.5	21.3	138.6	60696
		19.46	0.017	-2.52E-03	-103.1	21.3		
7	47.85	26.52	0.018	-2.50E-03	-91.6	-27.5		60696
8	47.50	31.32	0.019	-2.25E-03	-81.5	-57.9		60696
		30.88	0.019	-2.25E-03	-81.5	-57.9		
9	47.00	37.76	0.020	-1.62E-03	-64.4	-94.5		60696
10	46.50	44.57	0.020	-7.38E-04	-43.8	-121.7		60696
11	46.00	51.33	0.020	3.30E-04	-19.8	-137.9		60696
12	45.50	58.08	0.020	1.47E-03	7.6	-141.2		60696
13	45.00	64.84	0.019	2.59E-03	38.3	-129.0		60696
		24.40	0.019	2.59E-03	38.3	-129.0		
14	44.50	27.26	0.017	3.56E-03	51.2	-108.2		60696
15	44.17	29.17	0.016	4.10E-03	60.4	-90.4		60696
16	43.85	31.12	0.015	4.52E-03	70.2	-69.5		60696
17	43.65	32.35	0.014	4.73E-03	76.5	-54.9		60696
18	43.18	31.78	0.011	5.00E-03	91.6	-15.8		60696
		-71.37	0.011	5.00E-03	91.6	-15.8		
19	43.00	-75.18	0.011	5.03E-03	78.4	-0.5		60696
20	42.50	-85.81	0.008	4.91E-03	38.1	28.7		60696
21	42.00	-81.98	0.006	4.62E-03	-3.8	40.9		60696
22	41.50	-50.33	0.003	4.34E-03	-36.9	28.6		60696
23	41.13	18.16	0.002	4.21E-03	-42.9	13.5		60696
24	40.75	210.72	0.000	4.17E-03	0.0	-0.0		---

At elev. 48.35 Strut force = 138.6 kN/strut = 138.6 kN/m run

(continued)

Stage No.7 Fill to elevation 43.65 on RIGHT side with soil type 1

Node no.	Y coord	----- LEFT side -----					Total earth pressure kN/m2	Coeff. of subgrade reaction kN/m3
		Water press. kN/m2	Vertic -al kN/m2	Effective Active limit kN/m2	Effective Passive limit kN/m2	Earth pressure kN/m2		
1	49.75	0.00	0.00	0.00	0.00	0.00	0.00	5545
2	49.40	0.00	7.46	3.06	19.88	19.88	19.88p	5545
3	49.14	2.58	11.72	4.81	31.22	31.22	33.79p	5545
4	48.88	5.15	15.71	6.44	41.85	34.26	39.41	5545
5	48.61	7.73	19.22	7.88	51.19	21.38	29.11	5545
6	48.35	10.30	22.33	9.16	59.49	9.16	19.46a	5545
7	47.85	15.21	27.58	11.31	73.47	11.31	26.52a	2978
8	47.50	18.64	30.91	12.68	82.35	12.68	31.32a	2978
		18.64	30.91	12.23	86.18	12.24	30.88	8580
9	47.00	23.54	35.87	14.19	100.00	14.22	37.76	8580
10	46.50	28.45	40.58	16.06	113.14	16.12	44.57	8580
11	46.00	33.35	45.14	17.86	125.83	17.98	51.33	8580
12	45.50	38.26	49.58	19.62	138.22	19.82	58.08	8580
13	45.00	43.16	53.95	21.34	150.40	21.67	64.84	8580
		Total>	97.11	23.75m	182.48	24.40	24.40	16822
14	44.50	Total>	106.84	26.25m	196.47	27.26	27.26	17663
15	44.17	Total>	113.14	27.88m	205.55	29.17	29.17	18210
16	43.85	Total>	119.43	29.50m	214.62	31.12	31.12	18757
17	43.65	Total>	123.30	30.50m	220.20	32.35	32.35	19093
18	43.18	Total>	132.39	32.85m	233.30	35.25	35.25	19884
19	43.00	Total>	135.87	33.75m	238.31	36.36	36.36	20187
20	42.50	Total>	145.53	36.25m	252.25	39.43	39.43	21028
21	42.00	Total>	155.20	40.21	266.18	57.00	57.00	21869
22	41.50	Total>	164.88	45.47	280.13	102.43	102.43	22710
23	41.13	Total>	172.14	49.41	290.59	136.92	136.92	23341
24	40.75	Total>	177.09	51.04	298.74	226.09	226.09	23972

Node no.	Y coord	----- RIGHT side -----					Total earth pressure kN/m2	Coeff. of subgrade reaction kN/m3
		Water press. kN/m2	Vertic -al kN/m2	Effective Active limit kN/m2	Effective Passive limit kN/m2	Earth pressure kN/m2		
1	49.75	0.00	0.00	0.00	0.00	0.00	0.00	0.0
2	49.40	0.00	0.00	0.00	0.00	0.00	0.00	0.0
3	49.14	0.00	0.00	0.00	0.00	0.00	0.00	0.0
4	48.88	0.00	0.00	0.00	0.00	0.00	0.00	0.0
5	48.61	0.00	0.00	0.00	0.00	0.00	0.00	0.0
6	48.35	0.00	0.00	0.00	0.00	0.00	0.00	0.0
7	47.85	0.00	0.00	0.00	0.00	0.00	0.00	0.0
8	47.50	0.00	0.00	0.00	0.00	0.00	0.00	0.0
9	47.00	0.00	0.00	0.00	0.00	0.00	0.00	0.0
10	46.50	0.00	0.00	0.00	0.00	0.00	0.00	0.0
11	46.00	0.00	0.00	0.00	0.00	0.00	0.00	0.0
12	45.50	0.00	0.00	0.00	0.00	0.00	0.00	0.0
13	45.00	0.00	0.00	0.00	0.00	0.00	0.00	0.0
14	44.50	0.00	0.00	0.00	0.00	0.00	0.00	0.0
15	44.17	0.00	0.00	0.00	0.00	0.00	0.00	0.0
16	43.85	0.00	0.00	0.00	0.00	0.00	0.00	0.0
17	43.65	0.00	0.00	0.00	0.00	0.00	0.00	0.0
		0.00	0.00	0.00	0.00	0.00	0.00	2978
18	43.18	0.00	8.46	3.47	22.54	3.47	3.47a	2978
		Total>	8.46	2.35m	109.35	106.62	106.62	19884
19	43.00	Total>	12.06	3.25m	114.49	111.54	111.54	20187
20	42.50	Total>	22.06	5.75m	128.76	125.24	125.24	21028

(continued)

Stage No.7 Fill to elevation 43.65 on RIGHT side with soil type 1

Node no.	Y coord	----- RIGHT side -----					Total earth pressure	Coeff. of subgrade reaction
		Water press. kN/m2	Vertical kN/m2	Effective Active limit kN/m2	Effective Passive limit kN/m2	Earth pressure kN/m2		
21	42.00	Total>	32.06	8.25m	143.03	138.98	138.98	21869
22	41.50	Total>	42.06	10.75m	157.30	152.77	152.77	22710
23	41.13	Total>	49.57	12.63m	168.00	118.76	118.76	23341
24	40.75	Total>	57.07	14.50m	178.71	15.36	15.36	23972

Note: 3.47a Soil pressure at active limit
33.79p Soil pressure at passive limit

Units: kN,m

Stage No.7 Fill to elev. 43.65 on RIGHT side

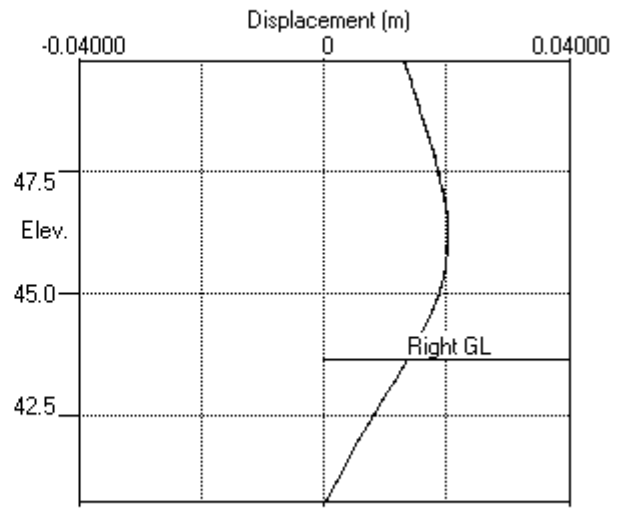
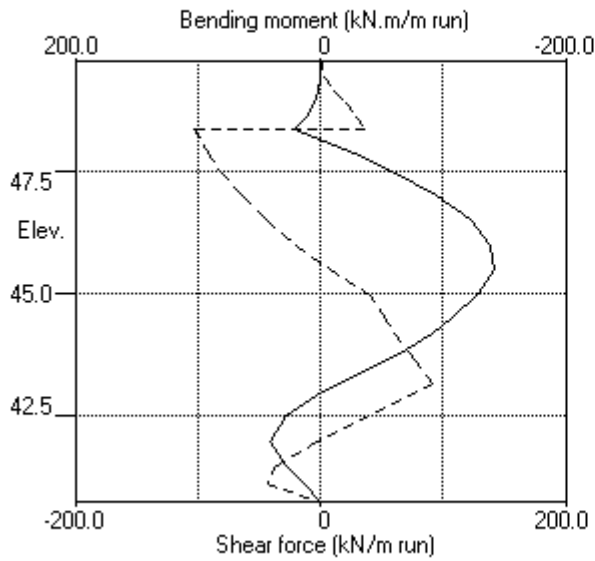

Stage No.7 Fill to elev. 43.65 on RIGHT side

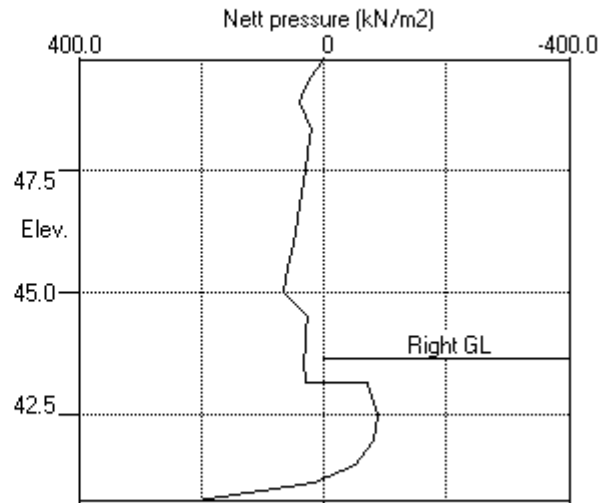
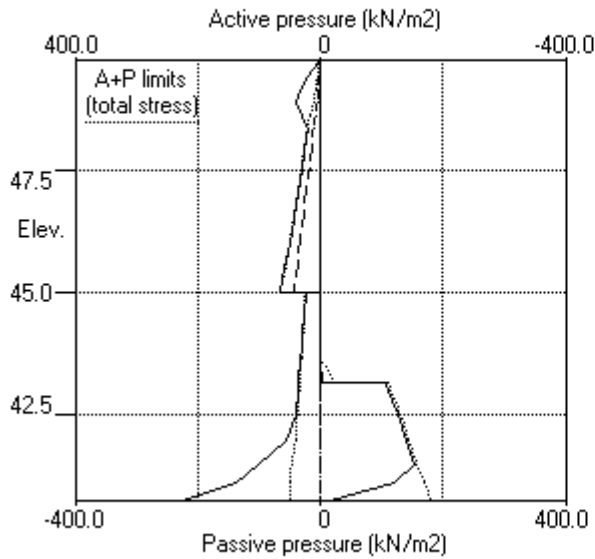

PILEDESIGNS LTD
 Program: WALLAP Version 6.06 Revision A51.B69.R54
 Licensed from GEOSOLVE
 Data filename/Run ID: Hampstead_Wall_1_450mm_rev_01_ULS2
 Hampstead - 24-26 Redington Gardens
 Wall 1, Secant-ULS2, 450 dia @ 650 - run 01

Sheet No.
 Job No. 21495
 Made by : DBS
 Date: 1-10-2018
 Checked :

Units: kN,m

Stage No. 9 Change EI of wall to 43355 kN.m²/m run
 Yield moment not defined
 Allow wall to relax with new modulus value

STABILITY ANALYSIS of Fully Embedded Wall according to Strength Factor method

Factor of safety on soil strength

		Overall					
		FoS for toe		Toe elev. for			
		elev. = 40.75		FoS = 1.000			

Stage No.	--- G.L. --- Act. Pass.	Strut Elev.	Factor of Safety	Moment of equilib. at elev.	Toe elev.	Wall Penetr -ation	Direction of failure
9	49.75 43.65		More than one strut.		No FoS calc.		

BENDING MOMENT and DISPLACEMENT ANALYSIS of Fully Embedded Wall

Analysis options

Length of wall perpendicular to section = 50.00m

Subgrade reaction model - Boussinesq Influence coefficients

Soil deformations are elastic until the active or passive limit is reached

Open Tension Crack analysis - No

Rigid boundaries: Left side 50.00 from wall

Right side 50.00 from wall

Limit State: ULS DA1 Combination 2

Node no.	Y coord	Nett pressure kN/m ²	Wall disp. m	Wall rotation rad.	Shear force kN/m	Bending moment kN.m/m	Strut forces kN/m	EI of wall kN.m ² /m
1	49.75	0.00	0.012	-2.91E-03	0.0	0.0		43355
2	49.40	19.88	0.013	-2.91E-03	3.5	0.5		43355
3	49.14	33.80	0.014	-2.92E-03	10.5	2.2		43355
4	48.88	41.51	0.015	-2.94E-03	20.4	5.9		43355
5	48.61	30.20	0.016	-3.00E-03	29.8	12.7		43355
6	48.35	19.50	0.017	-3.10E-03	36.3	21.6	131.9	43355
		19.50	0.017	-3.10E-03	-95.5	21.6		
7	47.85	26.52	0.018	-3.09E-03	-84.0	-24.3		43355
8	47.50	31.32	0.019	-2.79E-03	-73.9	-52.5		43355
		30.87	0.019	-2.79E-03	-73.9	-52.5		
9	47.00	37.73	0.020	-2.01E-03	-56.8	-86.2		43355
10	46.50	44.50	0.021	-9.16E-04	-36.2	-110.5		43355
11	46.00	51.21	0.021	3.92E-04	-12.3	-123.7		43355
12	45.50	57.87	0.021	1.76E-03	15.0	-124.1		43355
13	45.00	64.51	0.019	3.05E-03	45.6	-109.0		43355
		23.75	0.019	3.05E-03	45.6	-109.0		
14	44.50	26.25	0.018	4.10E-03	58.1	-85.5		43355
15	44.17	27.88	0.016	4.62E-03	66.9	-66.0		43355
16	43.85	30.47	0.015	4.97E-03	76.4	-43.5	29.8	43355
		30.47	0.015	4.97E-03	46.5	-43.5		
17	43.65	33.44	0.014	5.12E-03	52.9	-32.5		43355
18	43.18	36.46	0.011	5.25E-03	69.4	-1.9		43355
		-62.02	0.011	5.25E-03	69.4	-1.9		
19	43.00	-63.80	0.010	5.21E-03	58.0	10.4		43355
20	42.50	-71.22	0.008	4.94E-03	24.3	32.7		43355
21	42.00	-67.95	0.005	4.51E-03	-10.5	40.9		43355
22	41.50	-40.47	0.003	4.12E-03	-37.6	27.4		43355
23	41.13	23.17	0.002	3.95E-03	-40.9	12.6		43355
24	40.75	194.81	0.000	3.89E-03	0.0	-0.0		---

At elev. 48.35 Strut force = 131.9 kN/strut = 131.9 kN/m run

At elev. 43.85 Strut force = 29.8 kN/strut = 29.8 kN/m run

(continued)

Stage No.9 Change EI of wall to 43355 kN.m2/m run
 Yield moment not defined
 Allow wall to relax with new modulus value

Node no.	Y coord	LEFT side					Total earth pressure	Coeff. of subgrade reaction
		Water press.	Vertic -al	Active limit	Passive limit	Earth pressure		
		kN/m2	kN/m2	kN/m2	kN/m2	kN/m2	kN/m2	kN/m3
1	49.75	0.00	0.00	0.00	0.00	0.00	0.00	7104
2	49.40	0.00	7.46	3.06	19.88	19.88	19.88p	7104
3	49.14	2.58	11.72	4.81	31.22	31.22	33.80p	7104
4	48.88	5.15	15.71	6.44	41.85	36.36	41.51	7104
5	48.61	7.73	19.22	7.88	51.19	22.47	30.20	7104
6	48.35	10.30	22.33	9.16	59.49	9.20	19.50	7104
7	47.85	15.21	27.58	11.31	73.47	11.31	26.52a	2905
8	47.50	18.64	30.91	12.68	82.35	12.68	31.32a	2905
		18.64	30.91	12.23	86.18	12.23	30.87a	8369
9	47.00	23.54	35.87	14.19	100.00	14.19	37.73a	8369
10	46.50	28.45	40.58	16.06	113.14	16.06	44.50a	8369
11	46.00	33.35	45.14	17.86	125.83	17.86	51.21a	8369
12	45.50	38.26	49.58	19.62	138.22	19.62	57.87a	8369
13	45.00	43.16	53.95	21.34	150.40	21.34	64.51a	8369
		Total>	97.11	23.75m	182.48	23.75	23.75a	16449
14	44.50	Total>	106.84	26.25m	196.47	26.25	26.25a	17272
15	44.17	Total>	113.14	27.88m	205.55	27.88	27.88a	17806
16	43.85	Total>	119.43	29.50m	214.62	30.47	30.47	18341
17	43.65	Total>	123.30	30.50m	220.20	33.44	33.44	22939
18	43.18	Total>	132.39	32.85m	233.30	39.93	39.93	23888
19	43.00	Total>	135.87	33.75m	238.31	42.05	42.05	24252
20	42.50	Total>	145.53	36.25m	252.25	46.73	46.73	25263
21	42.00	Total>	155.20	40.21	266.18	64.02	64.02	26273
22	41.50	Total>	164.88	45.47	280.13	107.36	107.36	27284
23	41.13	Total>	172.14	49.41	290.59	139.43	139.43	28042
24	40.75	Total>	177.09	51.04	298.74	218.13	218.13	686495

Node no.	Y coord	RIGHT side					Total earth pressure	Coeff. of subgrade reaction
		Water press.	Vertic -al	Active limit	Passive limit	Earth pressure		
		kN/m2	kN/m2	kN/m2	kN/m2	kN/m2	kN/m2	kN/m3
1	49.75	0.00	0.00	0.00	0.00	0.00	0.00	0.0
2	49.40	0.00	0.00	0.00	0.00	0.00	0.00	0.0
3	49.14	0.00	0.00	0.00	0.00	0.00	0.00	0.0
4	48.88	0.00	0.00	0.00	0.00	0.00	0.00	0.0
5	48.61	0.00	0.00	0.00	0.00	0.00	0.00	0.0
6	48.35	0.00	0.00	0.00	0.00	0.00	0.00	0.0
7	47.85	0.00	0.00	0.00	0.00	0.00	0.00	0.0
8	47.50	0.00	0.00	0.00	0.00	0.00	0.00	0.0
9	47.00	0.00	0.00	0.00	0.00	0.00	0.00	0.0
10	46.50	0.00	0.00	0.00	0.00	0.00	0.00	0.0
11	46.00	0.00	0.00	0.00	0.00	0.00	0.00	0.0
12	45.50	0.00	0.00	0.00	0.00	0.00	0.00	0.0
13	45.00	0.00	0.00	0.00	0.00	0.00	0.00	0.0
14	44.50	0.00	0.00	0.00	0.00	0.00	0.00	0.0
15	44.17	0.00	0.00	0.00	0.00	0.00	0.00	0.0
16	43.85	0.00	0.00	0.00	0.00	0.00	0.00	0.0
17	43.65	0.00	0.00	0.00	0.00	0.00	0.00	0.0
		0.00	0.00	0.00	0.00	0.00	0.00	3634
18	43.18	0.00	8.46	3.47	22.54	3.47	3.47a	3634
		Total>	8.46	2.35m	109.35	101.94	101.94	23888

(continued)

Stage No.9 Change EI of wall to 43355 kN.m2/m run
 Yield moment not defined
 Allow wall to relax with new modulus value

Node no.	Y coord	----- RIGHT side -----						Total earth pressure	Coeff. of subgrade reaction
		Water press.	Vertical	Effective Active limit	Effective Passive limit	Earth pressure	Earth pressure		
		kN/m2	kN/m2	kN/m2	kN/m2	kN/m2	kN/m2	kN/m3	
19	43.00	Total>	12.06	3.25m	114.49	105.85	105.85	24252	
20	42.50	Total>	22.06	5.75m	128.76	117.95	117.95	25263	
21	42.00	Total>	32.06	8.25m	143.03	131.97	131.97	26273	
22	41.50	Total>	42.06	10.75m	157.30	147.84	147.84	27284	
23	41.13	Total>	49.57	12.63m	168.00	116.26	116.26	28042	
24	40.75	Total>	57.07	14.50m	178.71	23.32	23.32	686495	

Note: 3.47a Soil pressure at active limit
 33.80p Soil pressure at passive limit

Units: kN,m

Stage No.9 Change EI of wall to 43355kN.m2/m run

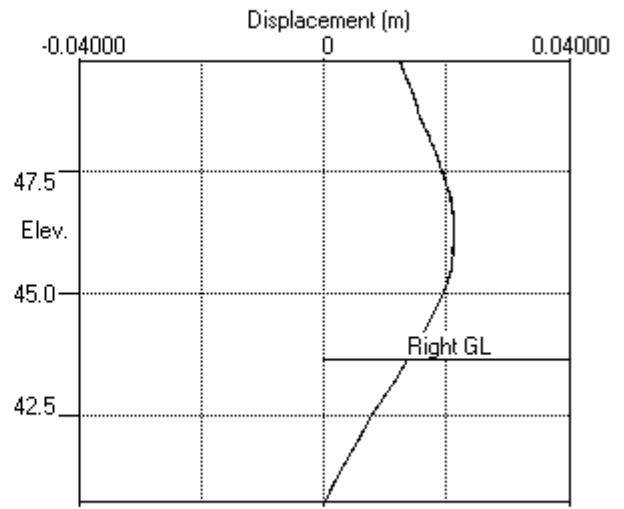
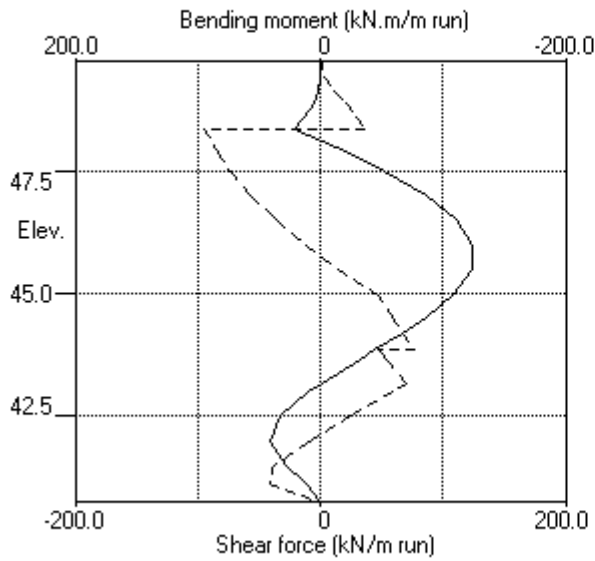

Stage No.9 Change EI of wall to 43355kN.m2/m run

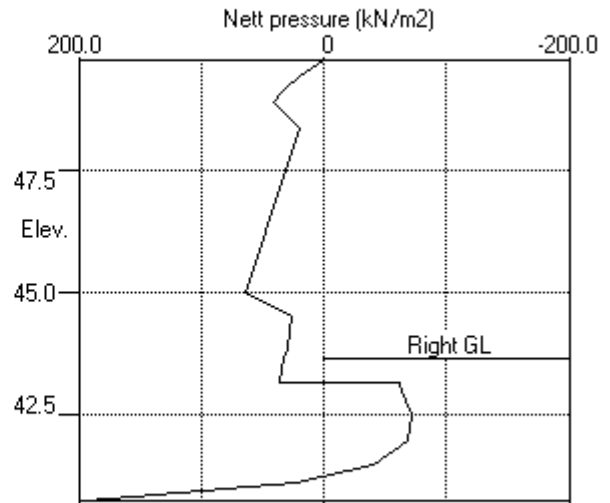
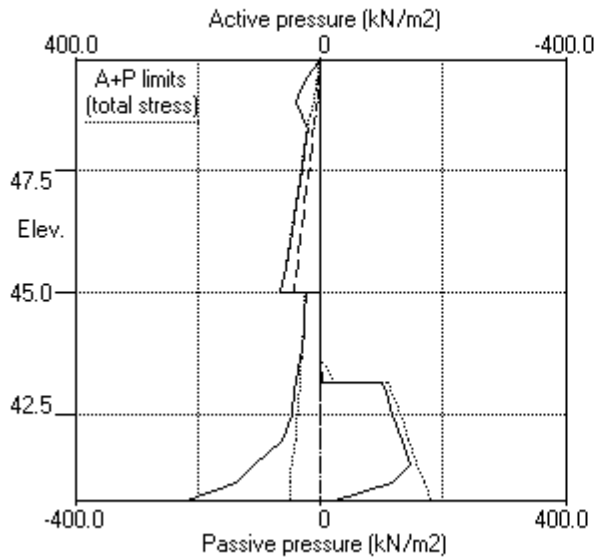

PILEDESIGNS LTD
 Program: WALLAP Version 6.06 Revision A51.B69.R54
 Licensed from GEOSOLVE
 Data filename/Run ID: Hampstead_Wall_1_450mm_rev_01_ULS2
 Hampstead - 24-26 Redington Gardens
 Wall 1, Secant-ULS2, 450 dia @ 650 - run 01

Sheet No.
 Job No. 21495
 Made by : DBS
 Date: 1-10-2018
 Checked :

Units: kN,m

Stage No. 10 Change properties of soil type 3 to soil type 4
 Ko pressures will not be reset

STABILITY ANALYSIS of Fully Embedded Wall according to Strength Factor method
 Factor of safety on soil strength

		Overall					
		FoS for toe		Toe elev. for			
		elev. = 40.75		FoS = 1.000			
		-----		-----			
Stage No.	--- G.L. --- Act. Pass.	Strut Elev.	Factor of Safety	Moment of equilib. at elev.	Toe elev.	Wall Penetr-ation	Direction of failure
10	49.75 43.65						
				More than one strut.	No FoS calc.		

** FLOW Warning - Weak strata at or below toe of wall:
 Active limit > Passive limit
 125.05kN/m2 (left) > 111.22kN/m2 (right) at elev. 40.75
 [40.20+84.86(u)] [89.15+22.07(u)]
 The above pressures include water pressure.

Failure and flow of soil BELOW the toe of the wall may occur if the wall is not toed in to a firm stratum. This may occur even when acceptable factors of safety and displacements have been calculated.

BENDING MOMENT and DISPLACEMENT ANALYSIS of Fully Embedded Wall

Analysis options

Length of wall perpendicular to section = 50.00m
 Subgrade reaction model - Boussinesq Influence coefficients
 Soil deformations are elastic until the active or passive limit is reached
 Open Tension Crack analysis - No

Rigid boundaries: Left side 50.00 from wall
 Right side 50.00 from wall

Limit State: ULS DA1 Combination 2

Node no.	Y coord	Nett pressure kN/m2	Wall disp. m	Wall rotation rad.	Shear force kN/m	Bending moment kN.m/m	Strut forces kN/m	EI of wall kN.m2/m
1	49.75	0.00	0.014	-1.53E-03	0.0	0.0		43355
2	49.40	9.39	0.015	-1.53E-03	1.6	0.5		43355
3	49.14	25.93	0.015	-1.54E-03	6.3	1.4		43355
4	48.88	36.27	0.016	-1.55E-03	14.4	3.7		43355
5	48.61	27.62	0.016	-1.59E-03	22.8	8.7		43355
6	48.35	19.56	0.016	-1.66E-03	29.0	15.7	110.7	43355
		19.56	0.016	-1.66E-03	-81.7	15.7		
7	47.85	28.69	0.017	-1.62E-03	-69.7	-23.2		43355
8	47.50	34.96	0.018	-1.35E-03	-58.5	-46.4		43355
		41.37	0.018	-1.35E-03	-58.5	-46.4		
9	47.00	54.01	0.018	-7.04E-04	-34.7	-71.0		43355
10	46.50	65.80	0.019	1.47E-04	-4.7	-82.3		43355
11	46.00	76.12	0.018	1.02E-03	30.8	-77.1		43355
12	45.50	84.11	0.018	1.72E-03	70.8	-52.8		43355
13	45.00	88.58	0.017	2.00E-03	114.0	-6.6		43355
		67.88	0.017	2.00E-03	114.0	-6.6		
14	44.50	73.05	0.016	1.63E-03	149.2	57.8		43355
15	44.17	77.56	0.015	9.60E-04	173.7	109.4		43355
16	43.85	82.07	0.015	-1.38E-04	199.6	169.3	351.0	43355
		82.07	0.015	-1.38E-04	-151.3	169.3		
17	43.65	84.85	0.015	-8.87E-04	-134.7	141.7		43355

(continued)

Stage No.10 Change properties of soil type 3 to soil type 4
Ko pressures will not be reset

Node no.	Y coord	----- RIGHT side -----					Total earth pressure kN/m2	Coeff. of subgrade reaction kN/m3
		Water press. kN/m2	Vertical kN/m2	Effective Active limit kN/m2	Effective Passive limit kN/m2	Earth pressure kN/m2		
8	47.50	0.00	0.00	0.00	0.00	0.00	0.00	0.0
9	47.00	0.00	0.00	0.00	0.00	0.00	0.00	0.0
10	46.50	0.00	0.00	0.00	0.00	0.00	0.00	0.0
11	46.00	0.00	0.00	0.00	0.00	0.00	0.00	0.0
12	45.50	0.00	0.00	0.00	0.00	0.00	0.00	0.0
13	45.00	0.00	0.00	0.00	0.00	0.00	0.00	0.0
14	44.50	0.00	0.00	0.00	0.00	0.00	0.00	0.0
15	44.17	0.00	0.00	0.00	0.00	0.00	0.00	0.0
16	43.85	0.00	0.00	0.00	0.00	0.00	0.00	0.0
17	43.65	0.00	0.00	0.00	0.00	0.00	0.00	0.0
		0.00	0.00	0.00	0.00	0.00	0.00	4299
18	43.18	0.00	8.46	3.47	22.54	22.54	22.54p	4299
		0.00	8.46	3.60	21.55	21.55	21.55p	15076
19	43.00	0.00	12.06	5.13	30.72	30.72	30.72p	15305
20	42.50	4.90	17.16	7.29	43.70	43.70	48.61p	15943
21	42.00	9.81	22.25	9.46	56.68	56.68	66.49p	16581
22	41.50	14.71	27.35	11.63	69.67	69.67	84.38p	17219
23	41.13	18.39	31.17	13.25	79.41	79.41	97.80p	17697
24	40.75	22.07	35.00	14.88	89.15	89.15	111.22p	18175

Note: 125.05a Soil pressure at active limit
111.22p Soil pressure at passive limit

Units: kN,m

Stage No.10 Change soil type 3 to soil type 4

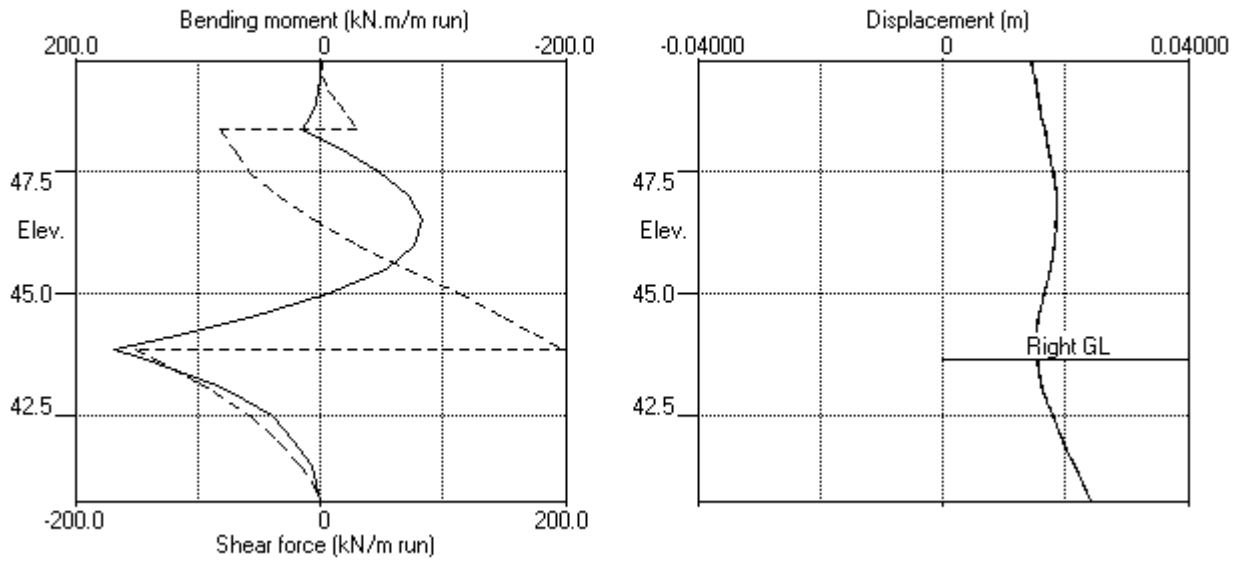

Stage No.10 Change soil type 3 to soil type 4

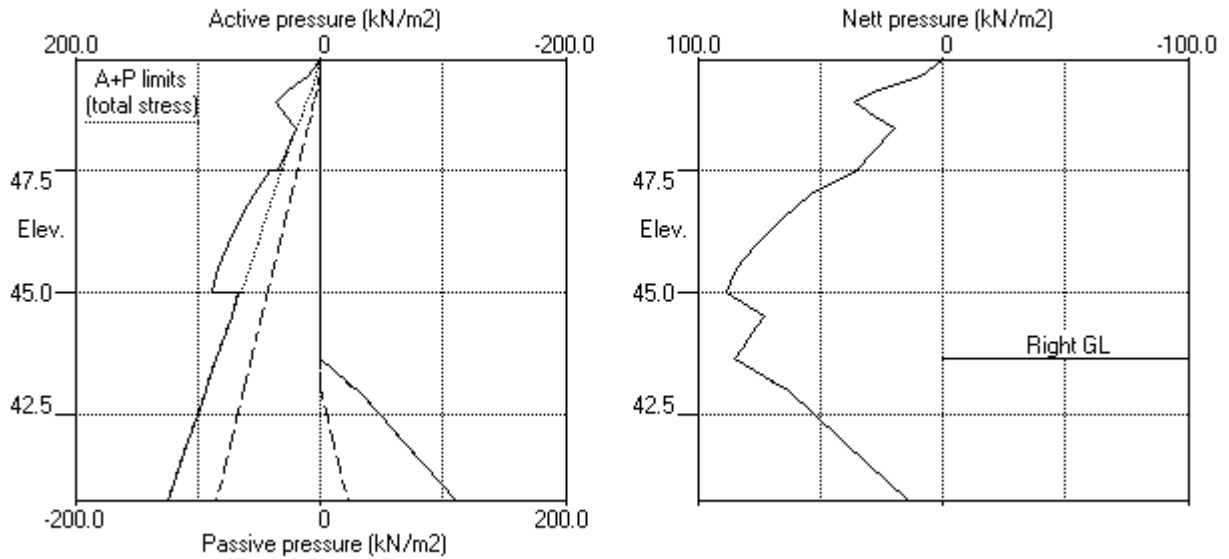

PILEDESIGNS LTD
 Program: WALLAP Version 6.06 Revision A51.B69.R54
 Licensed from GEOSOLVE
 Data filename/Run ID: Hampstead_Wall_1_450mm_rev_01_ULS2
 Hampstead - 24-26 Redington Gardens
 Wall 1, Secant-ULS2, 450 dia @ 650 - run 01

Sheet No.
 Job No. 21495
 Made by : DBS
 Date: 1-10-2018
 Checked :

Units: kN,m

Summary of results

LIMIT STATE PARAMETERS

Limit State: ULS DA1 Combination 2
 Water pressures : Worst Credible
 Partial factor on C' = 1.250
 Partial factor on Phi' = 1.250
 Partial factor on Cu = 1.400
 Partial factor on Soil Modulus = 1.000
 Partial factor on Permanent Unfavourable loads = 1.000
 Partial factor on Permanent Favourable loads = 1.000
 Partial factor on Variable Unfavourable loads = 1.300

STABILITY ANALYSIS of Fully Embedded Wall according to Strength Factor method

Factor of safety on soil strength

				Overall					
				FoS for toe		Toe elev. for			
				elev. = 40.75		FoS = 1.000			
				-----		-----			
Stage No.	--- G.L. Act.	--- Pass.	Strut Elev.	Factor of Safety	Moment at elev.	Toe elev.	Wall Penetr-ation	Direction of failure	
1	49.75	49.75	Cant.	Conditions not suitable for FoS calc.					
2	49.75	49.75	Cant.	Conditions not suitable for FoS calc.					
3	49.75	47.85	Cant.	1.667	41.78	43.10	4.75	L to R	
4	49.75	47.85		No analysis at this stage					
5	49.75	47.85	48.35	4.518	n/a	46.86	0.99	L to R	
6	49.75	43.18	48.35	1.326	n/a	42.12	1.06	L to R	
7	49.75	43.65	48.35	1.390	n/a	42.25	1.40	L to R	
8	49.75	43.65		No analysis at this stage					
9	49.75	43.65		More than one strut. No FoS calc.					
10	49.75	43.65		More than one strut. No FoS calc. **FLOW Warning					
11	49.75	43.65		No analysis at this stage					
12	49.75	43.65		More than one strut. No FoS calc.					

Legend: **FLOW Warning

Failure and flow of soil BELOW the toe of the wall may occur if the wall is not toed in to a firm stratum. It may occur even when acceptable factors of safety and displacements have been calculated. See individual stage results for details.

Units: kN,m

Summary of results

BENDING MOMENT and DISPLACEMENT ANALYSIS of Fully Embedded Wall

Analysis options

Length of wall perpendicular to section = 50.00m
 Subgrade reaction model - Boussinesq Influence coefficients
 Soil deformations are elastic until the active or passive limit is reached
 Open Tension Crack analysis - No

Rigid boundaries: Left side 50.00 from wall
 Right side 50.00 from wall

Limit State: ULS DA1 Combination 2

Bending moment, shear force and displacement envelopes

Node no.	Y coord	Displacement		Bending moment		Shear force	
		maximum m	minimum m	maximum kN.m/m	minimum kN.m/m	maximum kN/m	minimum kN/m
1	49.75	0.023	0.000	0.0	-0.0	0.0	0.0
2	49.40	0.022	0.000	0.5	-0.0	3.5	-0.9
3	49.14	0.020	0.000	2.2	-0.4	10.5	-2.0
4	48.88	0.019	0.000	5.9	-1.0	20.4	-2.4
5	48.61	0.018	0.000	12.7	-1.6	29.8	-2.2
6	48.35	0.017	0.000	21.6	-2.1	36.3	-103.1
7	47.85	0.018	0.000	14.6	-27.5	24.1	-91.6
8	47.50	0.019	0.000	24.4	-57.9	31.3	-81.5
9	47.00	0.020	0.000	41.1	-94.5	35.2	-64.4
10	46.50	0.021	0.000	58.4	-121.7	33.7	-43.8
11	46.00	0.021	0.000	73.7	-137.9	30.8	-19.8
12	45.50	0.021	0.000	84.0	-141.2	70.8	0.0
13	45.00	0.019	0.000	87.9	-129.0	114.0	-1.9
14	44.50	0.018	0.000	78.6	-108.2	149.2	-26.3
15	44.17	0.016	0.000	109.4	-90.4	173.7	-33.6
16	43.85	0.015	0.000	169.3	-69.5	199.6	-151.3
17	43.65	0.015	0.000	141.7	-54.9	76.5	-134.7
18	43.18	0.016	0.000	91.2	-16.3	91.6	-98.5
19	43.00	0.016	0.000	78.6	-1.3	78.4	-86.6
20	42.50	0.018	0.000	48.1	0.0	38.2	-57.8
21	42.00	0.020	0.000	40.9	0.0	0.0	-39.6
22	41.50	0.021	0.000	28.6	0.0	0.0	-37.6
23	41.13	0.023	0.000	13.5	0.0	0.0	-42.9
24	40.75	0.024	0.000	0.0	-0.0	0.0	0.0

Maximum and minimum bending moment and shear force at each stage

Stage no.	Bending moment				Shear force			
	maximum kN.m/m	elev.	minimum kN.m/m	elev.	maximum kN/m	elev.	minimum kN/m	elev.
1	1.8	43.65	-2.7	46.50	3.6	45.00	-1.3	47.50
2	4.8	44.17	-2.1	47.85	4.6	47.50	-2.4	48.88
3	87.9	45.00	0.0	49.75	35.2	47.00	-36.1	43.85
4	No calculation at this stage							
5	82.9	45.00	0.0	49.75	30.0	46.50	-34.2	43.65
6	40.1	42.00	-140.2	45.50	89.9	43.18	-102.8	48.35
7	40.9	42.00	-141.2	45.50	91.6	43.18	-103.1	48.35
8	No calculation at this stage							
9	40.9	42.00	-124.1	45.50	76.4	43.85	-95.5	48.35
10	169.3	43.85	-82.3	46.50	199.6	43.85	-151.3	43.85
11	No calculation at this stage							
12	148.0	43.85	-85.6	46.50	191.5	43.85	-108.0	43.85

Summary of results (continued)

Maximum and minimum displacement at each stage

Stage no.	Displacement maximum m	Displacement elev.	Displacement minimum m	Displacement elev.	Stage description
1	0.001	49.75	0.000	49.75	Apply surcharge no.1 at elev. 49.75
2	0.002	49.75	0.000	49.75	Apply water pressure profile no.1
3	0.023	49.75	0.000	49.75	Excav. to elev. 47.85 on RIGHT side
4	No calculation at this stage				Install strut no.1 at elev. 48.35
5	0.023	49.75	0.000	49.75	Apply water pressure profile no.2
6	0.020	46.00	0.000	49.75	Excav. to elev. 43.18 on RIGHT side
7	0.020	46.00	0.000	49.75	Fill to elev. 43.65 on RIGHT side
8	No calculation at this stage				Install strut no.2 at elev. 43.85
9	0.021	46.00	0.000	49.75	Change EI of wall to 43355kN.m2/m run
10	0.024	40.75	0.000	49.75	Change soil type 3 to soil type 4
11	No calculation at this stage				Apply surcharge no.2 at elev. 43.65
12	0.022	40.75	0.000	49.75	Apply water pressure profile no.3

Strut forces at each stage (horizontal components)

Stage no.	Strut no. 1 at elev. 48.35		Strut no. 2 at elev. 43.85	
	kN/m run	kN/strut	kN/m run	kN/strut
5	6.78	6.78	---	---
6	138.27	138.27	---	---
7	138.63	138.63	---	---
9	131.87	131.87	29.85	29.85
10	110.75	110.75	350.98	350.98
12	113.23	113.23	299.53	299.53

Units: kN,m

Bending moment, shear force, displacement envelopes

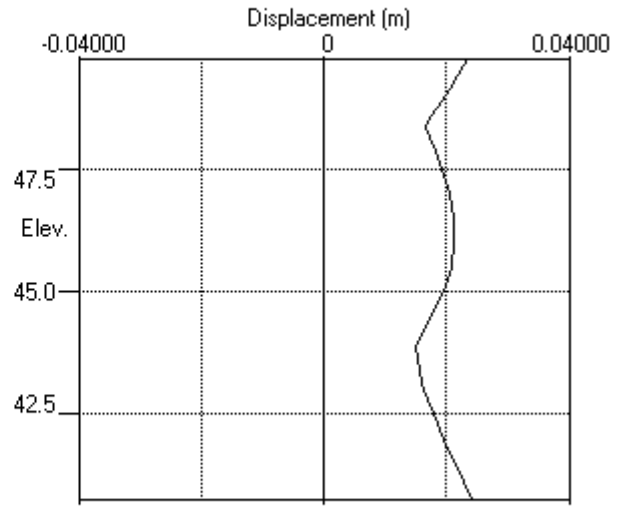
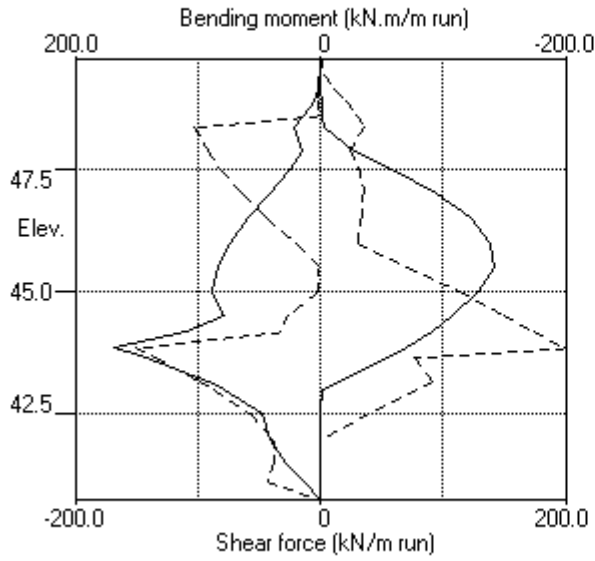



WALLAP

1-SLS

PILEDESIGNS LTD
 Program: WALLAP Version 6.06 Revision A51.B69.R54
 Licensed from GEOSOLVE
 Data filename/Run ID: Hampstead_Wall_1_450mm_rev_01_SLS
 Hampstead - 24-26 Redington Gardens
 Wall 1, Secant-SLS, 450 dia @ 650 - run 01

Sheet No.
 Job No. 21495
 Made by : DBS
 Date: 1-10-2018
 Checked :

Units: kN,m

INPUT DATA

SOIL PROFILE

Stratum no.	Elevation of top of stratum	Soil types	
		Left side	Right side
1	49.75	1 Made Ground dr	1 Made Ground dr
2	47.50	2 Claygate Clay dr	2 Claygate Clay dr
3	45.00	3 London Clay und	3 London Clay und

SOIL PROPERTIES

-- Soil type --	Bulk density	Young's Modulus	At rest coeff.	Consol state.	Active limit	Passive limit	Cohesion
No. Description (Datum elev.)	kN/m3	Eh,kN/m2 (dEh/dy)	Ko (dKo/dy)	NC/OC (Nu)	Ka (Kac)	Kp (Kpc)	kN/m2 (dc/dy)
1 Made Ground dr	18.00	10000	0.530	OC (0.250)	0.337 (0.000)	3.442 (0.000)	
2 Claygate Clay dr	19.00	30000	1.000	NC (0.200)	0.323 (1.330)	3.647 (5.195)	0.0d
3 London Cl.. (45.00)	20.00	40000 (4000)	1.000	OC (0.490)	1.000 (2.476)	1.000 (2.390)	50.00u (5.000)
4 London Cl.. (45.00)	20.00	30800 (3080)	1.000	OC (0.200)	0.351 (1.391)	3.253 (4.831)	0.0d

Additional soil parameters associated with Ka and Kp

No. Description	--- parameters for Ka ---			--- parameters for Kp ---		
	Soil friction angle	Wall adhesion coeff.	Back-fill angle	Soil friction angle	Wall adhesion coeff.	Back-fill angle
1 Made Ground dr	26.00	0.670	0.00	26.00	0.500	0.00
2 Claygate Clay dr	27.00	0.670	0.00	27.00	0.500	0.00
3 London Clay und	0.00	0.670	0.00	0.00	0.500	0.00
4 London Clay dr	25.00	0.670	0.00	25.00	0.500	0.00

GROUND WATER CONDITIONS

Density of water = 9.810 kN/m3

	Left side	Right side
Initial water table elevation	49.40	49.40

Automatic water pressure balancing at toe of wall : No

Water profile no.	Left side				Right side			
	Point no.	Elev. m	Piezo elev. m	Water press. kN/m2	Point no.	Elev. m	Piezo elev. m	Water press. kN/m2
1	1	49.40	49.40	0.0	1	47.50	47.50	0.0 MC+WC
2	1	49.40	49.40	0.0	1	43.00	43.00	0.0 MC+WC
3	1	49.40	49.40	0.0	1	43.65	43.65	0.0 MC+WC
					2	43.65	49.40	56.4

WALL PROPERTIES

Type of structure = Fully Embedded Wall
 Elevation of toe of wall = 40.75
 Maximum finite element length = 0.50 m
 Youngs modulus of wall E = 1.9600E+07 kN/m2
 Moment of inertia of wall I = 3.0968E-03 m4/m run
 E.I = 60696 kN.m2/m run
 Yield Moment of wall = Not defined

STRUTS and ANCHORS

Strut/ anchor no.	Elev.	Strut spacing m	X-section area of strut sq.m	Youngs modulus kN/m ²	Free length m	Inclin -ation (degs)	Pre- stress /strut kN	Tension allowed
1	48.35	1.00	0.400000	1.400E+07	5.00	0.00	0	No
2	43.85	1.00	0.300000	1.400E+07	5.00	0.00	0	No

SURCHARGE LOADS

Surch -arge no.	Elev.	Distance from wall	Length parallel to wall	Width perpend. to wall	Surcharge ----- kN/m ² ----- Near edge Far edge		Equiv. soil type	Partial factor/ Category
1	49.75	0.50(L)	10.00	10.00	10.00	=	N/A	1.00 Var
2	43.65	-0.00(R)	10.00	10.00	57.00	=	N/A	1.00 P/F

Note: L = Left side, R = Right side

Limit State Categories P/U = Permanent Unfavourable
P/F = Permanent Favourable
Var = Variable (unfavourable)

CONSTRUCTION STAGES

Construction stage no.	Stage description
1	Apply surcharge no.1 at elevation 49.75
2	Apply water pressure profile no.1 (Mod. Conserv.)
3	Excavate to elevation 47.85 on RIGHT side
4	Install strut or anchor no.1 at elevation 48.35
5	Apply water pressure profile no.2 (Mod. Conserv.)
6	Excavate to elevation 43.65 on RIGHT side
7	Install strut or anchor no.2 at elevation 43.85
8	Change EI of wall to 43355 kN.m ² /m run Yield moment not defined Allow wall to relax with new modulus value
9	Change properties of soil type 3 to soil type 4 Ko pressures will not be reset
10	Apply surcharge no.2 at elevation 43.65 No analysis at this stage
11	Apply water pressure profile no.3 (Mod. Conserv.)

FACTORS OF SAFETY and ANALYSIS OPTIONS

Limit State options: Serviceability Limit State
All loads and soil strengths are unfactored

Stability analysis:

Method of analysis - Strength Factor method
Factor on soil strength for calculating wall depth = 1.50

Parameters for undrained strata:

Minimum equivalent fluid density = 5.00 kN/m³
Maximum depth of water filled tension crack = 0.00 m

Bending moment and displacement calculation:

Method - Subgrade reaction model using Influence Coefficients
Open Tension Crack analysis? - No
Non-linear Modulus Parameter (L) = 9.000 m

Boundary conditions:

Length of wall (normal to plane of analysis) = 50.00 m

Width of excavation on Left side of wall = 50.00 m
Width of excavation on Right side of wall = 50.00 m

Distance to rigid boundary on Left side = 50.00 m
Distance to rigid boundary on Right side = 50.00 m

OUTPUT OPTIONS

Stage no.	Stage description	Displacement	Active, Passive pressures	Graph. output
1	Apply surcharge no.1 at elev. 49.75	No	No	No
2	Apply water pressure profile no.1	Yes	Yes	Yes
3	Excav. to elev. 47.85 on RIGHT side	Yes	Yes	Yes
4	Install strut no.1 at elev. 48.35	Yes	Yes	Yes
5	Apply water pressure profile no.2	Yes	Yes	Yes
6	Excav. to elev. 43.65 on RIGHT side	Yes	Yes	Yes
7	Install strut no.2 at elev. 43.85	Yes	Yes	Yes
8	Change EI of wall to 43355kN.m ² /m run	No	No	No
9	Change soil type 3 to soil type 4	No	No	No
10	Apply surcharge no.2 at elev. 43.65	No	No	No
11	Apply water pressure profile no.3	No	No	No
*	Summary output	Yes	-	Yes

Program WALLAP - Copyright (C) 2017 by DL Borin, distributed by GEOSOLVE
150 St. Alphonsus Road, London SW4 7BW, UK www.geosolve.co.uk

Units: kN,m

Stage No.11 Apply water pressure profile no.3 (Mod. Conserv.)

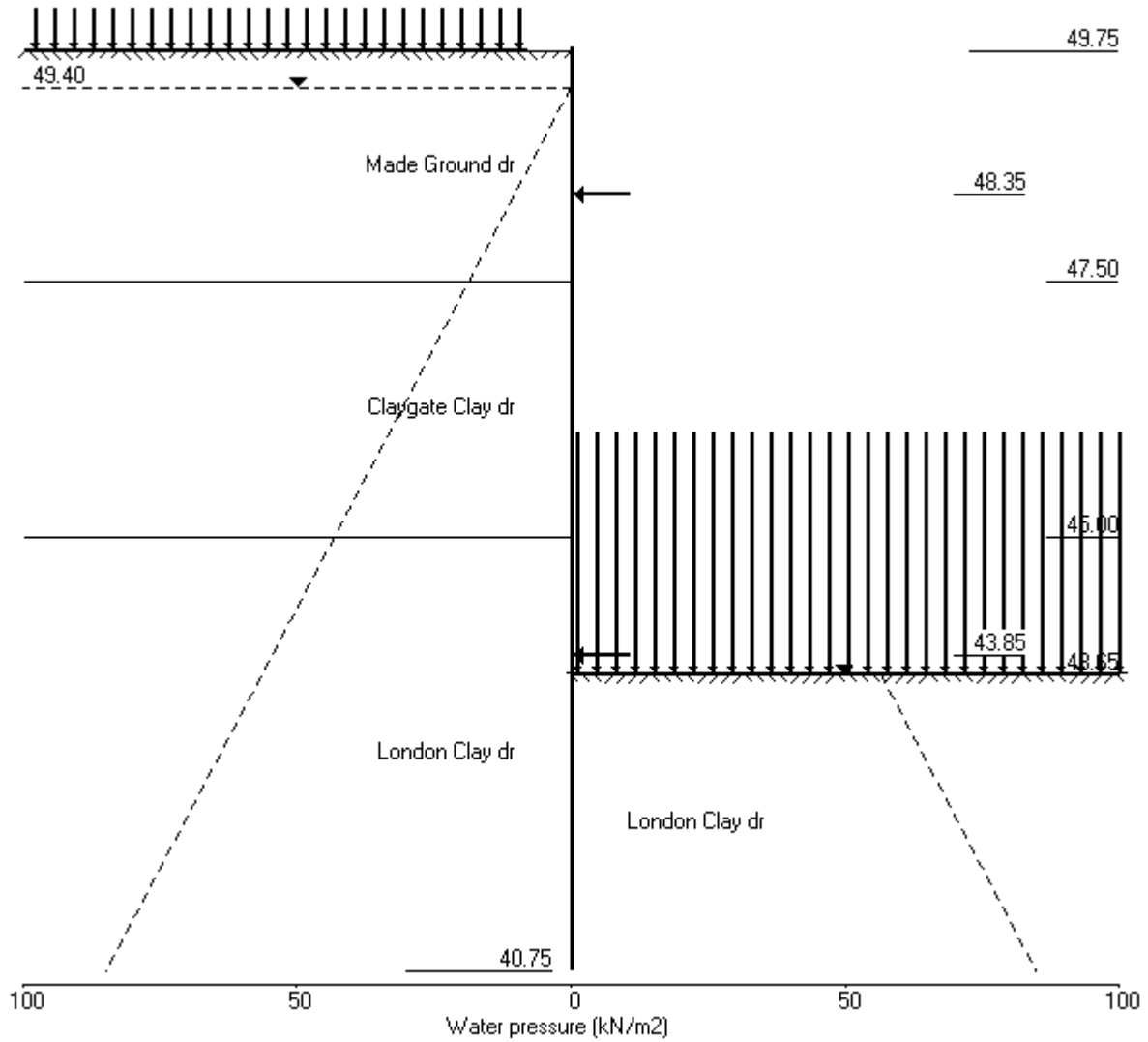

PILEDESIGNS LTD
 Program: WALLAP Version 6.06 Revision A51.B69.R54
 Licensed from GEOSOLVE
 Data filename/Run ID: Hampstead_Wall_1_450mm_rev_01_SLS
 Hampstead - 24-26 Redington Gardens
 Wall 1, Secant-SLS, 450 dia @ 650 - run 01

Sheet No.
 Job No. 21495
 Made by : DBS
 Date: 1-10-2018
 Checked :

Units: kN,m

Stage No. 3 Excavate to elevation 47.85 on RIGHT side

STABILITY ANALYSIS of Fully Embedded Wall according to Strength Factor method
 Factor of safety on soil strength

Stage No.	--- G.L. --- Act.	--- G.L. --- Pass.	Strut Elev.	FoS for toe elev. =	Moment of equil. at elev.	Toe elev. for FoS =	Wall Penetr-ation	Direction of failure
3	49.75	47.85	Cant.	2.294	41.81	42.58	5.27	L to R

BENDING MOMENT and DISPLACEMENT ANALYSIS of Fully Embedded Wall

Analysis options

Length of wall perpendicular to section = 50.00m
 Subgrade reaction model - Boussinesq Influence coefficients
 Soil deformations are elastic until the active or passive limit is reached
 Open Tension Crack analysis - No

Rigid boundaries: Left side 50.00 from wall
 Right side 50.00 from wall

Limit State: Serviceability Limit State

Calculated Bending Moments and Strut Forces are to be multiplied by a factor of 1.35 to obtain values for structural design. See summary for factored values.

Node no.	Y coord	Nett pressure kN/m2	Wall disp. m	Wall rotation rad.	Shear force kN/m	Bending moment kN.m/m	Strut forces kN/m	EI of wall kN.m2/m
1	49.75	0.00	0.011	2.67E-03	0.0	-0.0		60696
2	49.40	2.42	0.011	2.67E-03	0.4	0.1		60696
3	49.14	6.27	0.010	2.67E-03	1.6	0.4		60696
4	48.88	10.04	0.009	2.67E-03	3.7	1.1		60696
5	48.61	13.69	0.008	2.66E-03	6.8	2.4		60696
6	48.35	17.24	0.008	2.64E-03	10.9	4.7		60696
7	47.85	23.82	0.006	2.57E-03	21.1	12.6		60696
8	47.50	6.66	0.006	2.47E-03	26.5	21.1		60696
		4.96	0.006	2.47E-03	26.5	21.1		
9	47.00	-10.22	0.004	2.25E-03	25.2	34.3		60696
10	46.50	-25.47	0.003	1.92E-03	16.2	44.9		60696
11	46.00	-33.02	0.002	1.52E-03	1.6	51.2		60696
12	45.50	-18.07	0.002	1.12E-03	-11.2	47.9		60696
13	45.00	-7.96	0.001	7.58E-04	-17.7	40.0		60696
		-9.70	0.001	7.58E-04	-17.7	40.0		
14	44.50	0.92	0.001	4.70E-04	-19.9	30.0		60696
15	44.17	5.11	0.001	3.27E-04	-18.9	23.6		60696
16	43.85	7.59	0.001	2.16E-04	-16.8	17.7		60696
17	43.65	8.42	0.001	1.63E-04	-15.2	14.5		60696
18	43.33	8.89	0.001	9.83E-05	-12.4	10.0		60696
19	43.00	8.56	0.001	5.44E-05	-9.6	6.4		60696
20	42.50	7.07	0.001	1.68E-05	-5.7	2.7		60696
21	42.00	4.98	0.001	2.71E-06	-2.6	0.7		60696
22	41.50	2.70	0.001	-4.77E-07	-0.7	0.0		60696
23	41.13	0.97	0.001	-4.22E-07	-0.0	-0.1		60696
24	40.75	-0.79	0.001	-2.64E-07	0.0	-0.0		---

(continued)

Stage No.3 Excavate to elevation 47.85 on RIGHT side

Node no.	Y coord	LEFT side					Total earth pressure kN/m2	Coeff. of subgrade reaction kN/m3
		Water press. kN/m2	Vertic -al kN/m2	Effective Active limit kN/m2	Effective Passive limit kN/m2	Earth pressure kN/m2		
1	49.75	0.00	0.00	0.00	0.00	0.00	0.00	3582
2	49.40	0.00	7.20	2.42	24.77	2.42	2.42a	3582
3	49.14	2.58	10.97	3.69	37.75	3.69	6.27a	3582
4	48.88	5.15	14.53	4.89	50.02	4.89	10.04a	3582
5	48.61	7.73	17.72	5.97	61.01	5.97	13.69a	3582
6	48.35	10.30	20.62	6.94	70.97	6.94	17.24a	3582
7	47.85	15.21	25.60	8.62	88.12	8.62	23.82a	3582
8	47.50	18.64	28.82	9.70	99.22	9.70	28.34a	3582
		18.64	28.82	9.30	105.12	9.30	27.94a	10338
9	47.00	23.54	33.70	10.87	122.88	10.87	34.41a	10338
10	46.50	28.45	38.38	12.38	139.98	12.38	40.83a	10338
11	46.00	33.35	42.95	13.85	156.62	20.35	53.70	10338
12	45.50	38.26	47.42	15.30	172.95	31.43	69.69	10338
13	45.00	43.16	51.85	16.72	189.07	40.43	83.60	10338
		Total>	95.01	23.75m	214.51	72.37	72.37	19942
14	44.50	Total>	104.80	26.25m	230.27	86.95	86.95	20939
15	44.17	Total>	111.15	27.88m	240.50	95.24	95.24	21587
16	43.85	Total>	117.49	29.50m	250.73	102.79	102.79	22235
17	43.65	Total>	121.39	30.50m	257.02	107.13	107.13	22634
18	43.33	Total>	127.72	32.12m	267.23	113.79	113.79	23282
19	43.00	Total>	134.05	33.75m	277.45	120.10	120.10	23930
20	42.50	Total>	143.80	36.25m	293.17	129.38	129.38	24927
21	42.00	Total>	153.54	38.75m	308.89	138.38	138.38	25924
22	41.50	Total>	163.29	41.25m	324.61	147.31	147.31	26921
23	41.13	Total>	170.61	43.13m	336.41	153.99	153.99	27669
24	40.75	Total>	176.11	45.00m	346.39	160.67	160.67	28417

Node no.	Y coord	RIGHT side					Total earth pressure kN/m2	Coeff. of subgrade reaction kN/m3
		Water press. kN/m2	Vertic -al kN/m2	Effective Active limit kN/m2	Effective Passive limit kN/m2	Earth pressure kN/m2		
1	49.75	0.00	0.00	0.00	0.00	0.00	0.00	0.0
2	49.40	0.00	0.00	0.00	0.00	0.00	0.00	0.0
3	49.14	0.00	0.00	0.00	0.00	0.00	0.00	0.0
4	48.88	0.00	0.00	0.00	0.00	0.00	0.00	0.0
5	48.61	0.00	0.00	0.00	0.00	0.00	0.00	0.0
6	48.35	0.00	0.00	0.00	0.00	0.00	0.00	0.0
7	47.85	0.00	0.00	0.00	0.00	0.00	0.00	0.0
		0.00	0.00	0.00	0.00	0.00	0.00	4849
8	47.50	0.00	6.30	2.12	21.69	21.69	21.69p	4849
		0.00	6.30	2.03	22.98	22.98	22.98p	14025
9	47.00	4.90	10.90	3.51	39.73	39.73	44.64p	14025
10	46.50	9.81	15.49	5.00	56.49	56.49	66.30p	14025
11	46.00	14.71	20.09	6.48	73.25	72.00	86.72	14025
12	45.50	19.62	24.68	7.96	90.01	68.14	87.76	14025
13	45.00	24.52	29.28	9.44	106.77	67.03	91.56	14025
		Total>	53.80	14.25m	173.30	82.07	82.07	26520
14	44.50	Total>	63.80	16.75m	189.28	86.03	86.03	27846
15	44.17	Total>	70.31	18.37m	199.66	90.13	90.13	28707
16	43.85	Total>	76.81	20.00m	210.05	95.20	95.20	29569
17	43.65	Total>	80.81	21.00m	216.44	98.71	98.71	30100
18	43.33	Total>	87.31	22.62m	226.82	104.90	104.90	30962
19	43.00	Total>	93.81	24.25m	237.21	111.54	111.54	31823

(continued)

Stage No.3 Excavate to elevation 47.85 on RIGHT side

Node no.	Y coord	----- RIGHT side -----					Total earth pressure kN/m2	Coeff. of subgrade reaction kN/m3
		Water press. kN/m2	Vertic -al kN/m2	Effective Active limit kN/m2	Effective Passive limit kN/m2	Earth pressure kN/m2		
20	42.50	Total>	103.82	26.75m	253.19	122.31	122.31	33149
21	42.00	Total>	113.82	29.25m	269.17	133.40	133.40	34475
22	41.50	Total>	123.83	31.75m	285.15	144.61	144.61	35801
23	41.13	Total>	131.33	33.62m	297.14	153.03	153.03	36796
24	40.75	Total>	138.84	35.50m	309.12	161.46	161.46	37790

Note: 40.83a Soil pressure at active limit
 66.30p Soil pressure at passive limit

Units: kN,m

Stage No.3 Excav. to elev. 47.85 on RIGHT side

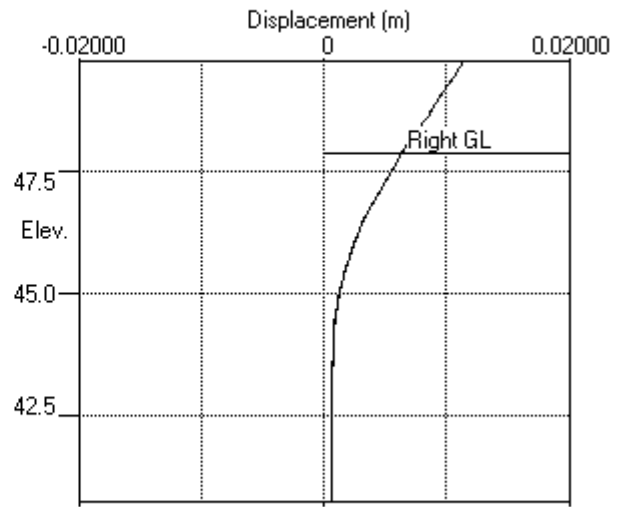
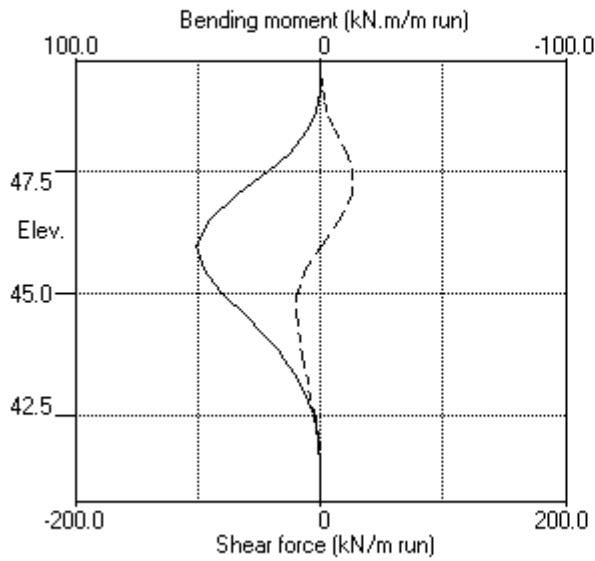

Stage No.3 Excav. to elev. 47.85 on RIGHT side

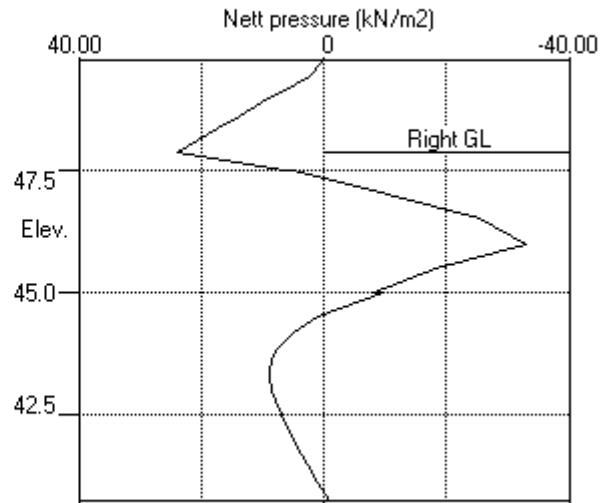
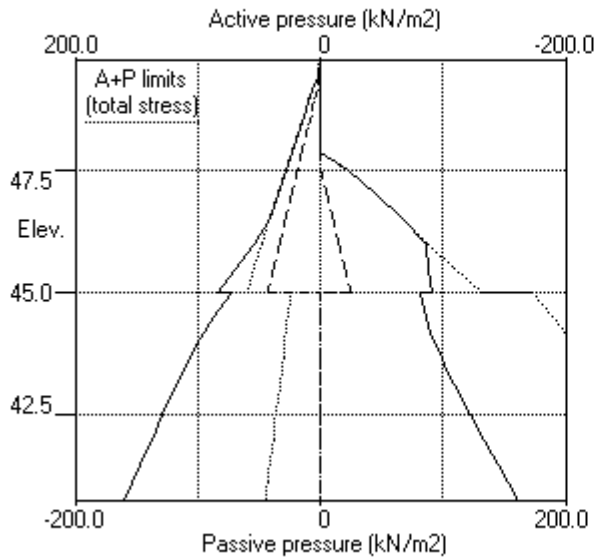

Units: kN,m

Stage No. 6 Excavate to elevation 43.65 on RIGHT side

STABILITY ANALYSIS of Fully Embedded Wall according to Strength Factor method
 Factor of safety on soil strength

				FoS for toe elev. = 40.75		Toe elev. for FoS = 1.500		
				-----		-----		
Stage No.	--- G.L. Act.	--- Pass.	Strut Elev.	Factor of Safety	Moment of equil. at elev.	Toe elev.	Wall Penetr-ation	Direction of failure
6	49.75	43.65	48.35	2.076	n/a	42.52	1.13	L to R

BENDING MOMENT and DISPLACEMENT ANALYSIS of Fully Embedded Wall

Analysis options

Length of wall perpendicular to section = 50.00m

Subgrade reaction model - Boussinesq Influence coefficients

Soil deformations are elastic until the active or passive limit is reached

Open Tension Crack analysis - No

Rigid boundaries: Left side 50.00 from wall

Right side 50.00 from wall

Limit State: Serviceability Limit State

Calculated Bending Moments and Strut Forces are to be multiplied by a factor of 1.35 to obtain values for structural design. See summary for factored values.

Node no.	Y coord	Nett pressure kN/m2	Wall disp. m	Wall rotation rad.	Shear force kN/m	Bending moment kN.m/m	Strut forces kN/m	EI of wall kN.m2/m
1	49.75	0.00	0.006	-1.52E-03	0.0	-0.0		60696
2	49.40	24.77	0.006	-1.52E-03	4.3	0.6		60696
3	49.14	29.97	0.007	-1.53E-03	11.5	2.4		60696
4	48.88	25.66	0.007	-1.55E-03	18.8	6.5		60696
5	48.61	21.18	0.007	-1.59E-03	25.0	12.3		60696
6	48.35	17.24	0.008	-1.66E-03	30.0	19.7	111.3	60696
		17.24	0.008	-1.66E-03	-81.3	19.7		
7	47.85	23.82	0.009	-1.66E-03	-71.0	-18.5		60696
8	47.50	28.34	0.009	-1.49E-03	-61.9	-41.8		60696
		27.94	0.009	-1.49E-03	-61.9	-41.8		
9	47.00	34.41	0.010	-1.03E-03	-46.3	-69.0		60696
10	46.50	40.83	0.010	-3.91E-04	-27.5	-87.6		60696
11	46.00	47.21	0.010	3.57E-04	-5.5	-94.2		60696
12	45.50	53.56	0.010	1.12E-03	19.7	-91.4		60696
13	45.00	59.89	0.009	1.80E-03	48.1	-75.1		60696
		23.75	0.009	1.80E-03	48.1	-75.1		
14	44.50	26.25	0.008	2.31E-03	60.6	-48.5		60696
15	44.17	27.88	0.007	2.52E-03	69.4	-27.5		60696
16	43.85	29.50	0.006	2.60E-03	78.7	-3.5		60696
17	43.65	30.50	0.006	2.58E-03	84.7	12.8		60696
		-105.13	0.006	2.58E-03	84.7	12.8		
18	43.33	-103.20	0.005	2.45E-03	50.8	36.0		60696
19	43.00	-91.54	0.004	2.22E-03	19.2	49.2		60696
20	42.50	-49.96	0.003	1.83E-03	-16.2	47.3		60696
21	42.00	-14.06	0.003	1.50E-03	-32.2	33.0		60696
22	41.50	17.92	0.002	1.30E-03	-31.2	15.1		60696
23	41.13	41.16	0.001	1.24E-03	-20.1	4.7		60696
24	40.75	66.29	0.001	1.22E-03	0.0	-0.0		---
At elev. 48.35 Strut force =			111.3 kN/strut =		111.3 kN/m run			

(continued)

Stage No.6 Excavate to elevation 43.65 on RIGHT side

Node no.	Y coord	----- LEFT side -----					Total earth pressure kN/m2	Coeff. of subgrade reaction kN/m3
		Water press. kN/m2	Vertic -al kN/m2	Effective Active limit kN/m2	Effective Passive limit kN/m2	Earth pressure kN/m2		
1	49.75	0.00	0.00	0.00	0.00	0.00	0.00	7307
2	49.40	0.00	7.20	2.42	24.77	24.77	24.77p	7307
3	49.14	2.58	10.97	3.69	37.75	27.39	29.97	7307
4	48.88	5.15	14.53	4.89	50.02	20.51	25.66	7307
5	48.61	7.73	17.72	5.97	61.01	13.45	21.18	7307
6	48.35	10.30	20.62	6.94	70.97	6.94	17.24a	2370
7	47.85	15.21	25.60	8.62	88.12	8.62	23.82a	2370
8	47.50	18.64	28.82	9.70	99.22	9.70	28.34a	2370
		18.64	28.82	9.30	105.12	9.30	27.94a	6810
9	47.00	23.54	33.70	10.87	122.88	10.87	34.41a	6810
10	46.50	28.45	38.38	12.38	139.98	12.38	40.83a	6810
11	46.00	33.35	42.95	13.85	156.62	13.85	47.21a	6810
12	45.50	38.26	47.42	15.30	172.95	15.30	53.56a	6810
13	45.00	43.16	51.85	16.72	189.07	16.72	59.89a	6810
		Total>	95.01	23.75m	214.51	23.75	23.75a	13719
14	44.50	Total>	104.80	26.25m	230.27	26.25	26.25a	14405
15	44.17	Total>	111.15	27.88m	240.50	27.88	27.88a	14850
16	43.85	Total>	117.49	29.50m	250.73	29.50	29.50a	15296
17	43.65	Total>	121.39	30.50m	257.02	30.50	30.50a	15571
18	43.33	Total>	127.72	32.12m	267.23	42.82	42.82	16017
19	43.00	Total>	134.05	33.75m	277.45	59.34	59.34	16462
20	42.50	Total>	143.80	36.25m	293.17	83.23	83.23	17148
21	42.00	Total>	153.54	38.75m	308.89	105.11	105.11	17834
22	41.50	Total>	163.29	41.25m	324.61	125.63	125.63	18520
23	41.13	Total>	170.61	43.13m	336.41	140.77	140.77	19035
24	40.75	Total>	176.11	45.00m	346.39	156.74	156.74	19549

Node no.	Y coord	----- RIGHT side -----					Total earth pressure kN/m2	Coeff. of subgrade reaction kN/m3
		Water press. kN/m2	Vertic -al kN/m2	Effective Active limit kN/m2	Effective Passive limit kN/m2	Earth pressure kN/m2		
1	49.75	0.00	0.00	0.00	0.00	0.00	0.00	0.0
2	49.40	0.00	0.00	0.00	0.00	0.00	0.00	0.0
3	49.14	0.00	0.00	0.00	0.00	0.00	0.00	0.0
4	48.88	0.00	0.00	0.00	0.00	0.00	0.00	0.0
5	48.61	0.00	0.00	0.00	0.00	0.00	0.00	0.0
6	48.35	0.00	0.00	0.00	0.00	0.00	0.00	0.0
7	47.85	0.00	0.00	0.00	0.00	0.00	0.00	0.0
8	47.50	0.00	0.00	0.00	0.00	0.00	0.00	0.0
9	47.00	0.00	0.00	0.00	0.00	0.00	0.00	0.0
10	46.50	0.00	0.00	0.00	0.00	0.00	0.00	0.0
11	46.00	0.00	0.00	0.00	0.00	0.00	0.00	0.0
12	45.50	0.00	0.00	0.00	0.00	0.00	0.00	0.0
13	45.00	0.00	0.00	0.00	0.00	0.00	0.00	0.0
14	44.50	0.00	0.00	0.00	0.00	0.00	0.00	0.0
15	44.17	0.00	0.00	0.00	0.00	0.00	0.00	0.0
16	43.85	0.00	0.00	0.00	0.00	0.00	0.00	0.0
17	43.65	0.00	0.00	0.00	0.00	0.00	0.00	0.0
		Total>	0.00	0.00	135.63	135.63	135.63p	30880
18	43.33	Total>	6.50	1.63m	146.01	146.01	146.01p	31764
19	43.00	Total>	13.00	3.25m	156.40	150.88	150.88	32648
20	42.50	Total>	23.00	5.75m	172.37	133.18	133.18	34009
21	42.00	Total>	33.00	8.25m	188.35	119.17	119.17	35369

(continued)

Stage No.6 Excavate to elevation 43.65 on RIGHT side

Node no.	Y coord	----- RIGHT side -----					Total earth pressure	Coeff. of subgrade reaction
		Water press. kN/m2	Vertical kN/m2	Effective Active limit kN/m2	Effective Passive limit kN/m2	Earth pressure kN/m2		
22	41.50	Total>	43.00	10.75m	204.33	107.72	107.72	36730
23	41.13	Total>	50.51	12.63m	216.31	99.61	99.61	37750
24	40.75	Total>	58.01	14.50m	228.29	90.46	90.46	38770

Note: 30.50a Soil pressure at active limit
 146.01p Soil pressure at passive limit

Units: kN,m

Stage No.6 Excav. to elev. 43.65 on RIGHT side

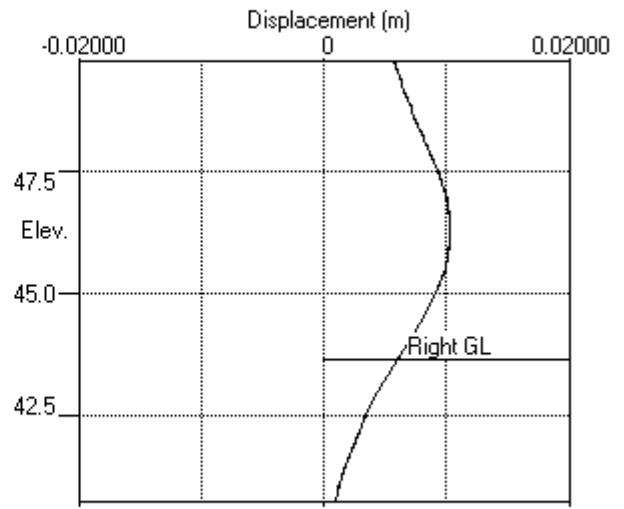
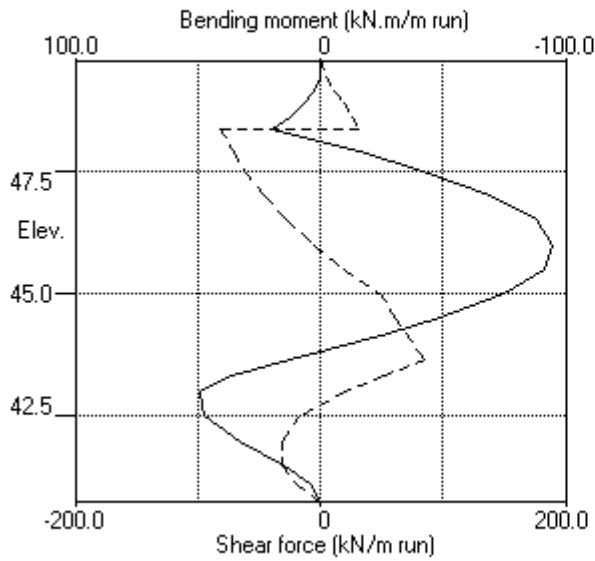

Stage No.6 Excav. to elev. 43.65 on RIGHT side

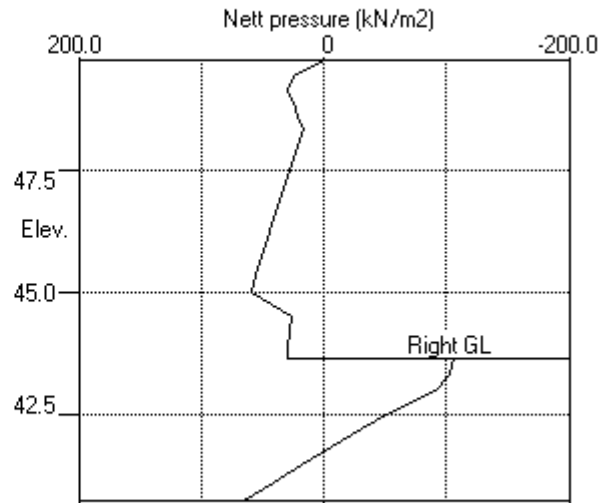
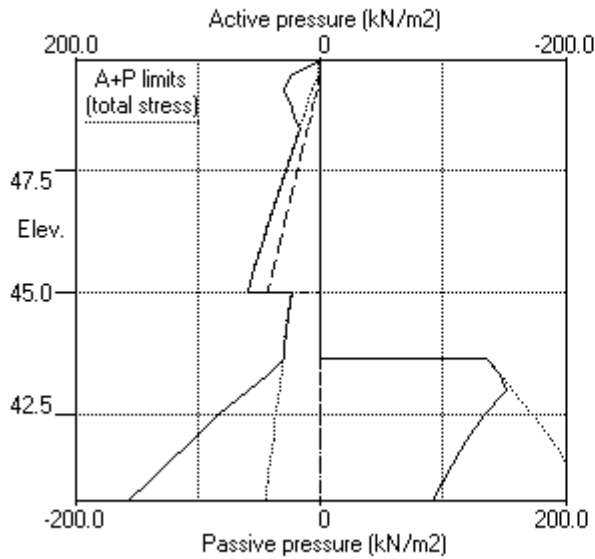

PILEDESIGNS LTD
 Program: WALLAP Version 6.06 Revision A51.B69.R54
 Licensed from GEOSOLVE
 Data filename/Run ID: Hampstead_Wall_1_450mm_rev_01_SLS
 Hampstead - 24-26 Redington Gardens
 Wall 1, Secant-SLS, 450 dia @ 650 - run 01

Sheet No.
 Job No. 21495
 Made by : DBS
 Date: 1-10-2018
 Checked :

Units: kN,m

Stage No. 8 Change EI of wall to 43355 kN.m²/m run
 Yield moment not defined
 Allow wall to relax with new modulus value

STABILITY ANALYSIS of Fully Embedded Wall according to Strength Factor method

Factor of safety on soil strength

Stage No.	--- G.L. --- Act. Pass.	Strut Elev.	FoS for toe elev. = 40.75	Moment of equil. at elev.	Toe elev. for FoS = 1.500	Wall Penetr-ation	Direction of failure
8	49.75 43.65			More than one strut.	No FoS calc.		

BENDING MOMENT and DISPLACEMENT ANALYSIS of Fully Embedded Wall

Analysis options

Length of wall perpendicular to section = 50.00m
 Subgrade reaction model - Boussinesq Influence coefficients
 Soil deformations are elastic until the active or passive limit is reached
 Open Tension Crack analysis - No

Rigid boundaries: Left side 50.00 from wall
 Right side 50.00 from wall

Limit State: Serviceability Limit State

Calculated Bending Moments and Strut Forces are to be multiplied by a factor of 1.35 to obtain values for structural design. See summary for factored values.

Node no.	Y coord	Nett pressure kN/m ²	Wall disp. m	Wall rotation rad.	Shear force kN/m	Bending moment kN.m/m	Strut forces kN/m	EI of wall kN.m ² /m
1	49.75	0.00	0.005	-1.97E-03	0.0	-0.0		43355
2	49.40	24.77	0.006	-1.98E-03	4.3	0.6		43355
3	49.14	32.65	0.006	-1.99E-03	11.9	2.4		43355
4	48.88	27.48	0.007	-2.01E-03	19.8	6.6		43355
5	48.61	22.12	0.007	-2.07E-03	26.3	12.7		43355
6	48.35	17.25	0.008	-2.17E-03	31.4	20.3	109.8	43355
		17.25	0.008	-2.17E-03	-78.3	20.3		
7	47.85	23.82	0.009	-2.20E-03	-68.1	-16.7		43355
8	47.50	28.34	0.010	-1.98E-03	-58.9	-39.2		43355
		27.94	0.010	-1.98E-03	-58.9	-39.2		
9	47.00	34.41	0.011	-1.39E-03	-43.3	-65.2		43355
10	46.50	40.83	0.011	-5.52E-04	-24.5	-82.7		43355
11	46.00	47.21	0.011	4.14E-04	-2.5	-88.1		43355
12	45.50	53.56	0.011	1.38E-03	22.7	-84.2		43355
13	45.00	59.89	0.010	2.23E-03	51.0	-66.7		43355
		23.75	0.010	2.23E-03	51.0	-66.7		
14	44.50	26.25	0.008	2.81E-03	63.5	-38.9		43355
15	44.17	27.88	0.007	2.99E-03	72.3	-17.2		43355
16	43.85	29.50	0.006	3.01E-03	81.6	7.6	18.7	43355
		29.50	0.006	3.01E-03	62.9	7.6		
17	43.65	31.80	0.006	2.93E-03	69.1	21.4		43355
		-102.52	0.006	2.93E-03	69.1	21.4		
18	43.33	-95.81	0.005	2.68E-03	36.8	40.8		43355
19	43.00	-81.13	0.004	2.33E-03	8.1	50.7		43355
20	42.50	-38.46	0.003	1.78E-03	-21.8	45.5		43355
21	42.00	-5.01	0.002	1.35E-03	-32.7	30.1		43355
22	41.50	22.31	0.002	1.11E-03	-28.4	12.9		43355
23	41.13	41.59	0.001	1.04E-03	-16.4	3.5		43355

(continued)

Stage No.8 Change EI of wall to 43355 kN.m2/m run
 Yield moment not defined
 Allow wall to relax with new modulus value

Node no.	Y coord	RIGHT side						
		Water press. kN/m2	Vertic -al kN/m2	Effective Active limit kN/m2	Effective Passive limit kN/m2	Earth pressure kN/m2	Total earth pressure kN/m2	Coeff. of subgrade reaction kN/m3
14	44.50	0.00	0.00	0.00	0.00	0.00	0.00	0.0
15	44.17	0.00	0.00	0.00	0.00	0.00	0.00	0.0
16	43.85	0.00	0.00	0.00	0.00	0.00	0.00	0.0
17	43.65	0.00	0.00	0.00	0.00	0.00	0.00	0.0
		Total>	0.00	0.00	135.63	134.33	134.33	24446
18	43.33	Total>	6.50	1.63m	146.01	142.32	142.32	25146
19	43.00	Total>	13.00	3.25m	156.40	145.68	145.68	25846
20	42.50	Total>	23.00	5.75m	172.37	127.44	127.44	26923
21	42.00	Total>	33.00	8.25m	188.35	114.64	114.64	28000
22	41.50	Total>	43.00	10.75m	204.33	105.52	105.52	29077
23	41.13	Total>	50.51	12.63m	216.31	99.40	99.40	66886
24	40.75	Total>	58.01	14.50m	228.29	100.71	100.71	146964

Note: 29.50a Soil pressure at active limit
 24.77p Soil pressure at passive limit

Units: kN,m

Stage No.8 Change EI of wall to 43355kN.m2/m run

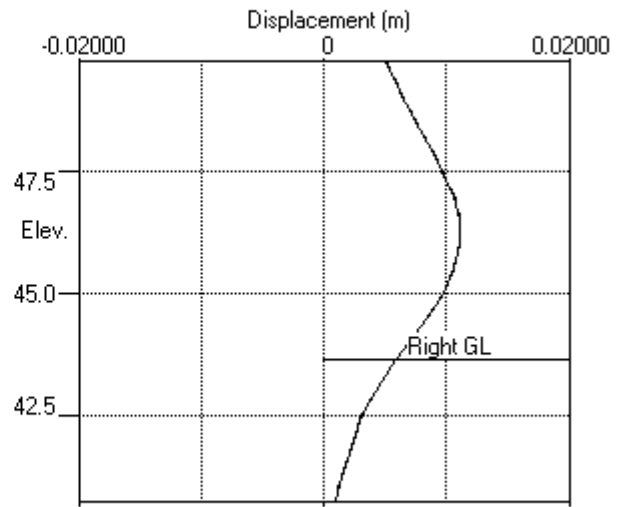
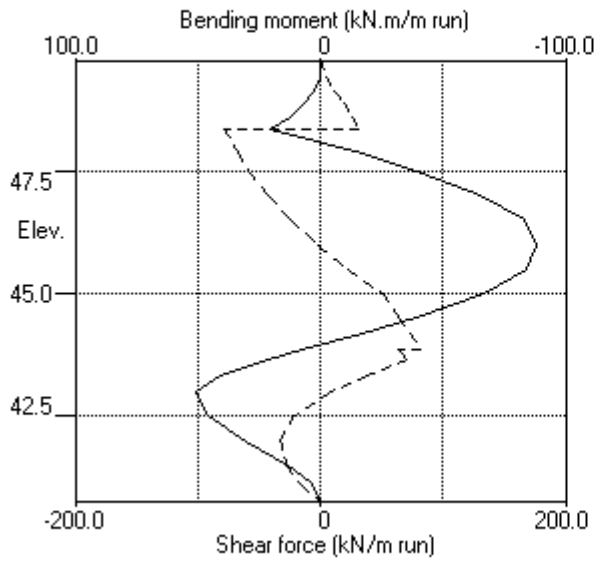

Stage No.8 Change EI of wall to 43355kN.m2/m run

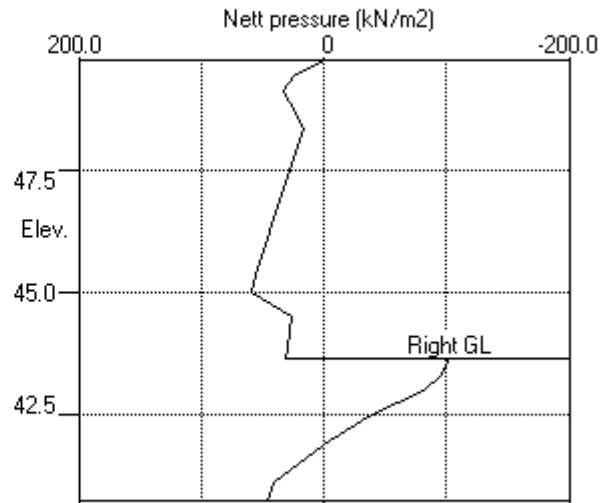
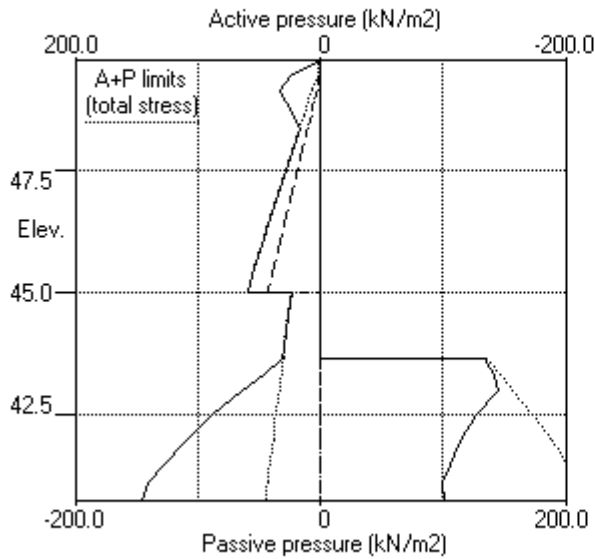

Units: kN,m

Stage No. 9 Change properties of soil type 3 to soil type 4
 Ko pressures will not be reset

STABILITY ANALYSIS of Fully Embedded Wall according to Strength Factor method
 Factor of safety on soil strength

			FoS for toe	Toe elev. for			
			elev. = 40.75	FoS = 1.500			

Stage	--- G.L. ---	Strut	Factor	Moment	Toe	Wall	Direction
No.	Act. Pass.	Elev.	of	equilib.	elev.	Penetr	of
			Safety	at elev.		-ation	failure
9	49.75 43.65		More than one strut.	No FoS calc.			

BENDING MOMENT and DISPLACEMENT ANALYSIS of Fully Embedded Wall

Analysis options

Length of wall perpendicular to section = 50.00m
 Subgrade reaction model - Boussinesq Influence coefficients
 Soil deformations are elastic until the active or passive limit is reached
 Open Tension Crack analysis - No

Rigid boundaries: Left side 50.00 from wall
 Right side 50.00 from wall

Limit State: Serviceability Limit State

Calculated Bending Moments and Strut Forces are to be multiplied by a factor of 1.35 to obtain values for structural design. See summary for factored values.

Node no.	Y coord	Nett pressure kN/m2	Wall disp. m	Wall rotation rad.	Shear force kN/m	Bending moment kN.m/m	Strut forces kN/m	EI of wall kN.m2/m
1	49.75	0.00	0.005	-1.79E-03	0.0	-0.0		43355
2	49.40	23.33	0.006	-1.79E-03	4.1	0.6		43355
3	49.14	31.57	0.006	-1.80E-03	11.3	2.3		43355
4	48.88	26.77	0.007	-1.82E-03	18.9	6.3		43355
5	48.61	21.77	0.007	-1.88E-03	25.3	12.2		43355
6	48.35	17.26	0.008	-1.98E-03	30.4	19.5	106.5	43355
		17.26	0.008	-1.98E-03	-76.0	19.5		
7	47.85	24.13	0.009	-2.00E-03	-65.7	-16.3		43355
8	47.50	28.85	0.009	-1.78E-03	-56.4	-38.0		43355
		29.40	0.009	-1.78E-03	-56.4	-38.0		
9	47.00	36.66	0.010	-1.21E-03	-39.9	-62.6		43355
10	46.50	43.73	0.011	-4.22E-04	-19.8	-78.1		43355
11	46.00	50.52	0.011	4.76E-04	3.7	-80.8		43355
12	45.50	56.92	0.010	1.34E-03	30.6	-73.3		43355
13	45.00	62.77	0.009	2.03E-03	60.5	-51.4		43355
		61.38	0.009	2.03E-03	60.5	-51.4		
14	44.50	68.00	0.008	2.38E-03	92.9	-14.1		43355
15	44.17	72.29	0.007	2.34E-03	115.7	19.5		43355
16	43.85	76.59	0.007	2.01E-03	139.9	60.7	228.6	43355
		76.59	0.007	2.01E-03	-88.8	60.7		
17	43.65	79.23	0.006	1.76E-03	-73.2	45.2		43355
18	43.33	62.38	0.006	1.47E-03	-50.2	27.5		43355
19	43.00	45.53	0.005	1.30E-03	-32.6	16.9		43355
20	42.50	30.66	0.005	1.17E-03	-13.6	4.8		43355
21	42.00	15.78	0.004	1.15E-03	-2.0	0.1		43355
22	41.50	0.90	0.004	1.16E-03	2.2	-0.9		43355
23	41.13	-5.56	0.003	1.17E-03	1.3	-0.3		43355
24	40.75	-1.44	0.003	1.18E-03	0.0	-0.0		---
At elev. 48.35 Strut force =			106.5 kN/strut =		106.5 kN/m run			
At elev. 43.85 Strut force =			228.6 kN/strut =		228.6 kN/m run			

(continued)

Stage No.9 Change properties of soil type 3 to soil type 4
Ko pressures will not be reset

Node no.	Y coord	LEFT side						Total earth pressure kN/m2	Coeff. of subgrade reaction kN/m3
		Effective stresses							
		Water press. kN/m2	Vertic -al kN/m2	Active limit kN/m2	Passive limit kN/m2	Earth pressure kN/m2			
1	49.75	0.00	0.00	0.00	0.00	0.00	0.00	7258	
2	49.40	0.00	7.20	2.42	24.77	23.33	23.33	7258	
3	49.14	2.58	10.97	3.69	37.75	29.00	31.57	7258	
4	48.88	5.15	14.53	4.89	50.02	21.62	26.77	7258	
5	48.61	7.73	17.72	5.97	61.01	14.04	21.77	7258	
6	48.35	10.30	20.62	6.94	70.97	6.96	17.26	2953	
7	47.85	15.21	25.60	8.62	88.12	8.92	24.13	2953	
8	47.50	18.64	28.82	9.70	99.22	10.21	28.85	2953	
		18.64	28.82	9.30	105.12	10.76	29.40	8507	
9	47.00	23.54	33.70	10.87	122.88	13.11	36.66	8507	
10	46.50	28.45	38.38	12.38	139.98	15.28	43.73	8507	
11	46.00	33.35	42.95	13.85	156.62	17.17	50.52	8507	
12	45.50	38.26	47.42	15.30	172.95	18.66	56.92	8507	
13	45.00	43.16	51.85	16.72	189.07	19.60	62.77	8507	
		43.16	51.85	18.21	168.64	18.21	61.38a	8734	
14	44.50	48.07	56.73	19.93	184.52	19.93	68.00a	9171	
15	44.17	51.26	59.89	21.04	194.80	21.04	72.29a	9455	
16	43.85	54.45	63.04	22.14	205.06	22.14	76.59a	10421	
17	43.65	56.41	64.98	22.83	211.36	22.83	79.23a	10608	
18	43.33	59.60	68.12	23.93	221.60	23.93	83.53a	10912	
19	43.00	62.78	71.27	25.04	231.82	25.04	87.82a	11216	
20	42.50	67.69	76.11	26.73	247.56	26.73	94.42a	11683	
21	42.00	72.59	80.95	28.43	263.30	28.43	101.03a	12150	
22	41.50	77.50	85.79	30.14	279.06	30.14	107.64a	12618	
23	41.13	81.18	89.43	31.41	290.90	36.11	117.29	12968	
24	40.75	84.86	93.07	32.69	302.75	38.02	122.88	13319	

Node no.	Y coord	RIGHT side						Total earth pressure kN/m2	Coeff. of subgrade reaction kN/m3
		Effective stresses							
		Water press. kN/m2	Vertic -al kN/m2	Active limit kN/m2	Passive limit kN/m2	Earth pressure kN/m2			
1	49.75	0.00	0.00	0.00	0.00	0.00	0.00	0.0	
2	49.40	0.00	0.00	0.00	0.00	0.00	0.00	0.0	
3	49.14	0.00	0.00	0.00	0.00	0.00	0.00	0.0	
4	48.88	0.00	0.00	0.00	0.00	0.00	0.00	0.0	
5	48.61	0.00	0.00	0.00	0.00	0.00	0.00	0.0	
6	48.35	0.00	0.00	0.00	0.00	0.00	0.00	0.0	
7	47.85	0.00	0.00	0.00	0.00	0.00	0.00	0.0	
8	47.50	0.00	0.00	0.00	0.00	0.00	0.00	0.0	
9	47.00	0.00	0.00	0.00	0.00	0.00	0.00	0.0	
10	46.50	0.00	0.00	0.00	0.00	0.00	0.00	0.0	
11	46.00	0.00	0.00	0.00	0.00	0.00	0.00	0.0	
12	45.50	0.00	0.00	0.00	0.00	0.00	0.00	0.0	
13	45.00	0.00	0.00	0.00	0.00	0.00	0.00	0.0	
14	44.50	0.00	0.00	0.00	0.00	0.00	0.00	0.0	
15	44.17	0.00	0.00	0.00	0.00	0.00	0.00	0.0	
16	43.85	0.00	0.00	0.00	0.00	0.00	0.00	0.0	
17	43.65	0.00	0.00	0.00	0.00	0.00	0.00	0.0	
		0.00	0.00	0.00	0.00	0.00	0.00	10608	
18	43.33	0.00	6.50	2.28	21.14	21.14	21.14p	10912	
19	43.00	0.00	13.00	4.57	42.29	42.29	42.29p	11216	
20	42.50	4.90	18.10	6.36	58.86	58.86	63.77p	11683	

(continued)

Stage No.9 Change properties of soil type 3 to soil type 4
 Ko pressures will not be reset

Node no.	Y coord	----- RIGHT side -----					Total earth pressure	Coeff. of subgrade reaction
		Water press.	Vertic -al	Effective Active limit	Effective Passive limit	Earth pressure		
		kN/m2	kN/m2	kN/m2	kN/m2	kN/m2	kN/m2	kN/m3
21	42.00	9.81	23.19	8.15	75.44	75.44	85.25p	12150
22	41.50	14.71	28.29	9.94	92.02	92.02	106.73p	12618
23	41.13	18.39	32.11	11.28	104.45	104.45	122.85p	12968
24	40.75	22.07	35.94	12.62	116.89	102.25	124.32	13319

Note: 107.64a Soil pressure at active limit
 122.85p Soil pressure at passive limit

Units: kN,m

Stage No.9 Change soil type 3 to soil type 4

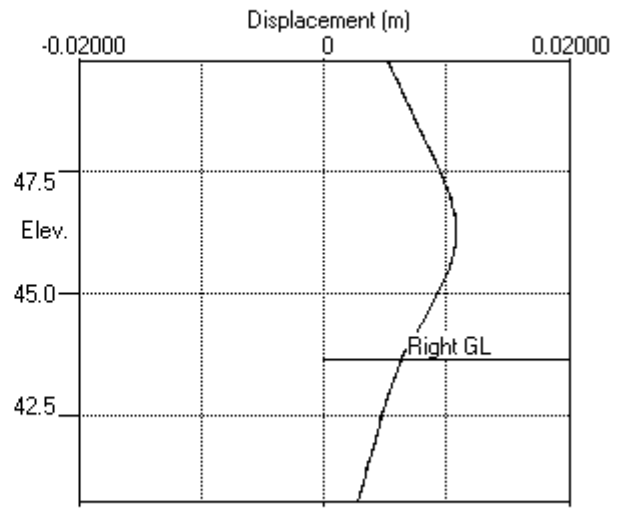
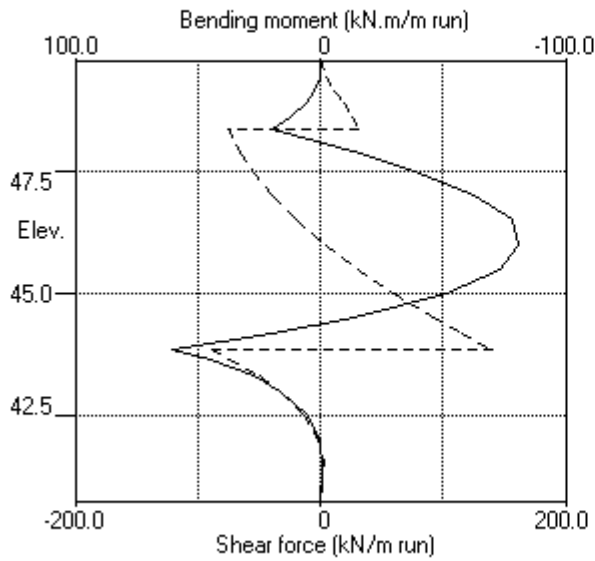

Stage No.9 Change soil type 3 to soil type 4

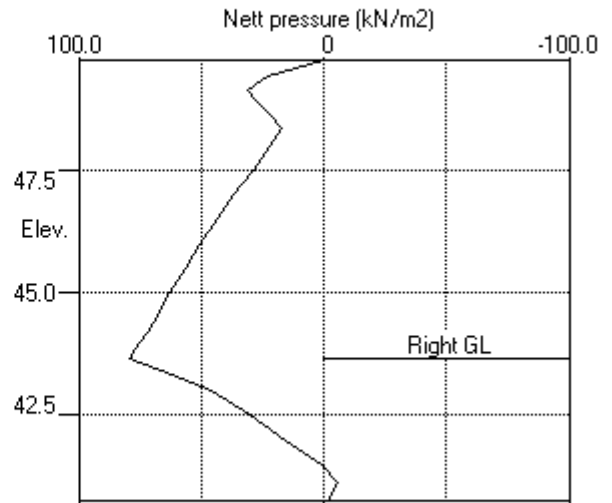
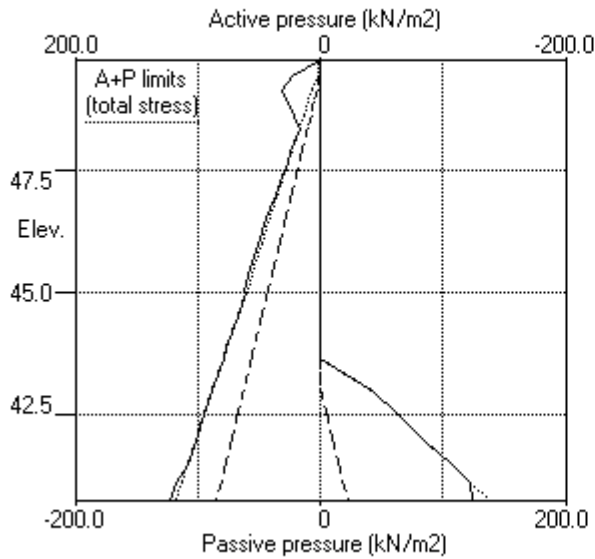

PILEDESIGNS LTD
 Program: WALLAP Version 6.06 Revision A51.B69.R54
 Licensed from GEOSOLVE
 Data filename/Run ID: Hampstead_Wall_1_450mm_rev_01_SLS
 Hampstead - 24-26 Redington Gardens
 Wall 1, Secant-SLS, 450 dia @ 650 - run 01

Sheet No.
 Job No. 21495
 Made by : DBS
 Date: 1-10-2018
 Checked :

 Units: kN,m

Summary of results

LIMIT STATE PARAMETERS

Limit State: Serviceability Limit State
 All loads and soil strengths are unfactored

STABILITY ANALYSIS of Fully Embedded Wall according to Strength Factor method
 Factor of safety on soil strength

Stage No.	G.L.		Strut Elev.	FoS for toe elev. = 40.75		Toe elev. for FoS = 1.500		Direction of failure
	Act.	Pass.		Factor of Safety	Moment at elev.	Toe elev.	Wall Penetration	
1	49.75	49.75	Cant.	Conditions not suitable for FoS calc.				
2	49.75	49.75	Cant.	Conditions not suitable for FoS calc.				
3	49.75	47.85	Cant.	2.294	41.81	42.58	5.27	L to R
4	49.75	47.85		No analysis at this stage				
5	49.75	47.85	48.35	6.545	n/a	46.44	1.41	L to R
6	49.75	43.65	48.35	2.076	n/a	42.52	1.13	L to R
7	49.75	43.65		No analysis at this stage				

All remaining stages have more than one strut - FoS calculation n/a

PILEDESIGNS LTD
 Program: WALLAP Version 6.06 Revision A51.B69.R54
 Licensed from GEOSOLVE
 Data filename/Run ID: Hampstead_Wall_1_450mm_rev_01_SLS
 Hampstead - 24-26 Redington Gardens
 Wall 1, Secant-SLS, 450 dia @ 650 - run 01

Sheet No.
 Job No. 21495
 Made by : DBS
 Date: 1-10-2018
 Checked :

Units: kN,m

Summary of results

BENDING MOMENT and DISPLACEMENT ANALYSIS of Fully Embedded Wall

Analysis options

Length of wall perpendicular to section = 50.00m
 Subgrade reaction model - Boussinesq Influence coefficients
 Soil deformations are elastic until the active or passive limit is reached
 Open Tension Crack analysis - No

Rigid boundaries: Left side 50.00 from wall
 Right side 50.00 from wall

Limit State: Serviceability Limit State

Calculated Bending Moments and Strut Forces have been multiplied by a factor of 1.35 to obtain values for structural design.

Bending moment, shear force and displacement envelopes

Node no.	Y coord	Displacement		Bending moment				Shear force			
		max. m	min. m	Calculated kN.m/m		Factored kN.m/m		Calculated kN/m		Factored kN/m	
1	49.75	0.011	0.000	0	-0	0	-0	0	0	0	0
2	49.40	0.011	0.000	1	0	1	0	4	-1	6	-1
3	49.14	0.010	0.000	2	-0	3	-0	12	-2	16	-2
4	48.88	0.009	0.000	7	-1	9	-1	20	-2	27	-3
5	48.61	0.008	0.000	13	-1	17	-2	26	-2	35	-3
6	48.35	0.008	0.000	20	-2	27	-3	31	-81	42	-110
7	47.85	0.009	0.000	13	-19	17	-25	21	-71	29	-96
8	47.50	0.010	0.000	21	-42	29	-56	26	-62	36	-84
9	47.00	0.011	0.000	34	-69	46	-93	25	-46	34	-63
10	46.50	0.011	0.000	45	-88	61	-118	16	-27	22	-37
11	46.00	0.011	0.000	51	-94	69	-127	4	-5	5	-7
12	45.50	0.011	0.000	48	-91	65	-123	31	-11	41	-15
13	45.00	0.010	0.000	40	-75	54	-101	61	-18	82	-24
14	44.50	0.008	0.000	30	-48	40	-65	93	-20	125	-27
15	44.17	0.008	0.000	24	-27	33	-37	116	-19	156	-25
16	43.85	0.007	0.000	61	-3	82	-5	140	-89	189	-120
17	43.65	0.006	0.000	45	0	61	0	85	-73	114	-99
18	43.33	0.006	0.000	41	0	55	0	51	-50	69	-68
19	43.00	0.005	0.000	51	0	68	0	19	-33	26	-44
20	42.50	0.005	0.000	47	0	64	0	0	-22	0	-29
21	42.00	0.004	0.000	33	0	45	0	0	-33	0	-44
22	41.50	0.004	0.000	15	-1	20	-1	2	-31	3	-42
23	41.13	0.003	0.000	5	-0	6	-0	1	-20	2	-27
24	40.75	0.003	0.000	0	-0	0	-0	0	0	0	0

Summary of results (continued)

Calculated Bending Moments and Strut Forces have been multiplied by a factor of 1.35 to obtain values for structural design.

Maximum and minimum bending moment and shear force at each stage

Stage no.	Bending moment				Shear force			
	Calculated		Factored		Calculated		Factored	
min.	max. elev.	min. elev.	max. elev.	max. elev.	min. elev.	max. elev.	min. elev.	max. elev.
	kN.m/m	kN.m/m	kN.m/m	kN/m	kN/m	kN/m	kN/m	kN/m
1	43.33	-3 46.50	2 -4	3 45.00	-1 47.85	4		
-2	44.17	-2 47.85	5 -3	4 47.50	-2 48.88	5		
-3	51 46.00	-0 41.13	69 -0	26 47.50	-20 44.50	36		
-27	No calculation at this stage							
4	43 46.00	-0 49.75	58 -0	21 47.50	-15 44.17	29		
-20	49 43.00	-94 46.00	66 -127	85 43.65	-81 48.35	114		
-110	No calculation at this stage							
7	51 43.00	-88 46.00	68 -119	82 43.85	-78 48.35	110		
-106	61 43.85	-81 46.00	82 -109	140 43.85	-89 43.85	189		
-120	No calculation at this stage							
10	41 43.85	-86 46.00	56 -116	133 43.85	-78 48.35	179		
-105								

Maximum and minimum displacement at each stage

Stage no.	Displacement				Stage description
	maximum elev.	minimum elev.	maximum elev.	minimum elev.	
	m	m	m	m	
1	0.001 47.85	0.000 49.75	0.001 49.75	0.000 49.75	Apply surcharge no.1 at elev. 49.75
2	0.001 49.75	0.000 49.75	0.011 49.75	0.000 49.75	Apply water pressure profile no.1
3	0.011 49.75	0.000 49.75	0.011 49.75	0.000 49.75	Excav. to elev. 47.85 on RIGHT side
4	No calculation at this stage				Install strut no.1 at elev. 48.35
5	0.011 49.75	0.000 49.75	0.011 49.75	0.000 49.75	Apply water pressure profile no.2
6	0.010 46.00	0.000 49.75	0.010 46.00	0.000 49.75	Excav. to elev. 43.65 on RIGHT side
7	No calculation at this stage				Install strut no.2 at elev. 43.85
8	0.011 46.00	0.000 49.75	0.011 46.00	0.000 49.75	Change EI of wall to 43355kN.m ² /m run
9	0.011 46.50	0.000 49.75	0.011 46.50	0.000 49.75	Change soil type 3 to soil type 4
10	No calculation at this stage				Apply surcharge no.2 at elev. 43.65
11	0.011 46.00	0.000 49.75	0.011 46.00	0.000 49.75	Apply water pressure profile no.3

Strut forces at each stage (horizontal components)

Stage no.	Strut no. 1			Strut no. 2		
	at elev. 48.35			at elev. 43.85		
	Calculated	Factored	Calculated	Factored	Calculated	Factored
	kN per m run	kN per strut	kN per m run	kN per strut	kN per m run	kN per strut
5	6	6	8	8	---	---
6	111	111	150	150	---	---
8	110	110	148	148	19	19
9	106	106	144	144	229	229
11	109	109	147	147	182	182

Units: kN,m

Bending moment, shear force, displacement envelopes

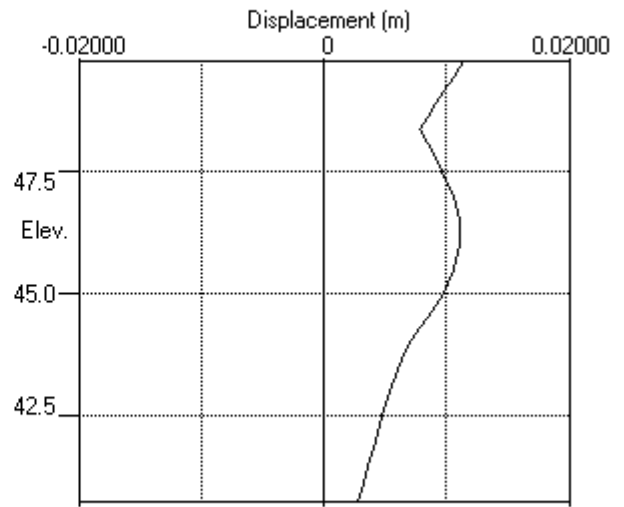
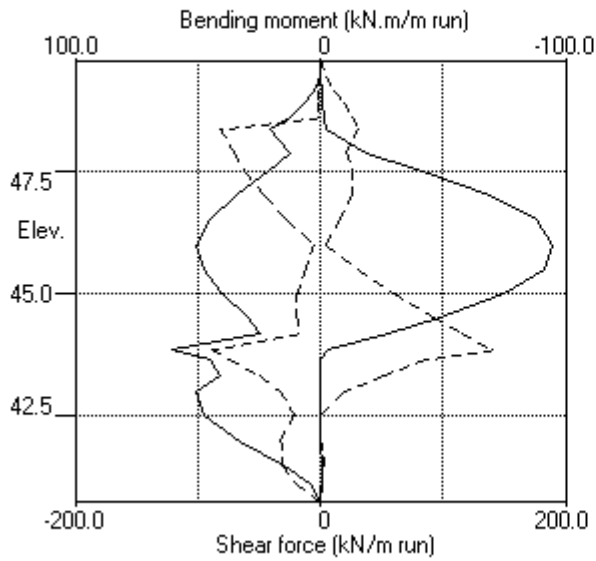



WALLAP

2-ULS1

PILEDESIGNS LTD
 Program: WALLAP Version 6.06 Revision A51.B69.R54
 Licensed from GEOSOLVE
 Data filename/Run ID: Hampstead_Wall_2_450mm_rev_01_ULS1
 Hampstead - 24-26 Redington Gardens
 Wall 2, Secant-ULS1, 450 dia @ 650 - run 01

Sheet No.
 Job No. 21495
 Made by : DBS
 Date: 1-10-2018
 Checked :

Units: kN,m

INPUT DATA

SOIL PROFILE

Stratum no.	Elevation of top of stratum	Soil types	
		Left side	Right side
1	49.75	1 Made Ground dr	1 Made Ground dr
2	47.50	2 Claygate Clay dr	2 Claygate Clay dr
3	45.00	3 London Clay und	3 London Clay und

SOIL PROPERTIES (Unfactored SLS soil strengths)

No. Description	Bulk density kN/m3	Young's Modulus Eh, kN/m2	At rest coeff. Ko	Consol state. NC/OC	Active limit Ka	Passive limit Kp	Cohesion kN/m2
(Datum elev.)		(dEh/dy)	(dKo/dy)	(Nu)	(Kac)	(Kpc)	(dc/dy)
1 Made Ground dr	18.00	10000	0.530	OC (0.250)	0.337 (0.000)	3.442 (0.000)	
2 Claygate Clay dr	19.00	30000	1.000	NC (0.200)	0.323 (1.330)	3.647 (5.195)	0.0d
3 London Cl.. (45.00)	20.00	40000 (4000)	1.000	OC (0.490)	1.000 (2.476)	1.000 (2.390)	50.00u (5.000)
4 London Cl.. (45.00)	20.00	30800 (3080)	1.000	OC (0.200)	0.351 (1.391)	3.253 (4.831)	0.0d

Additional soil parameters associated with Ka and Kp

No. Description	--- parameters for Ka ---			--- parameters for Kp ---		
	Soil friction angle	Wall adhesion coeff.	Back-fill angle	Soil friction angle	Wall adhesion coeff.	Back-fill angle
1 Made Ground dr	26.00	0.670	0.00	26.00	0.500	0.00
2 Claygate Clay dr	27.00	0.670	0.00	27.00	0.500	0.00
3 London Clay und	0.00	0.670	0.00	0.00	0.500	0.00
4 London Clay dr	25.00	0.670	0.00	25.00	0.500	0.00

GROUND WATER CONDITIONS

Density of water = 9.810 kN/m3

	Left side	Right side
Initial water table elevation	49.40	49.40

Automatic water pressure balancing at toe of wall : No

Water profile no.	Left side			Right side		
	Point no.	Elev. m	Piezo elev. m	Point no.	Elev. m	Piezo elev. m
1	1	49.40	49.40	1	47.50	47.50
2	1	49.40	49.40	1	43.00	43.00
3	1	49.40	49.40	1	43.85	43.85
				2	43.85	49.40

WALL PROPERTIES

Type of structure = Fully Embedded Wall
 Elevation of toe of wall = 40.75
 Maximum finite element length = 0.50 m
 Youngs modulus of wall E = 1.9600E+07 kN/m2
 Moment of inertia of wall I = 3.0968E-03 m4/m run
 E.I = 60696 kN.m2/m run
 Yield Moment of wall = Not defined

STRUTS and ANCHORS

Strut/ anchor no.	Elev.	Strut spacing m	X-section area of strut sq.m	Youngs modulus kN/m ²	Free length m	Inclin -ation (degs)	Pre- stress /strut kN	Tension allowed
1	48.20	1.00	0.300000	1.400E+07	5.00	0.00	0	No
2	44.05	1.00	0.300000	1.400E+07	5.00	0.00	0	No

SURCHARGE LOADS

Surch -arge no.	Elev.	Distance from wall	Length parallel to wall	Width perpend. to wall	Surcharge ----- kN/m ² ----- Near edge Far edge		Equiv. soil type	Partial factor/ Category
1	49.75	0.50(L)	10.00	10.00	13.00	=	N/A	1.10 Var
2	43.85	-0.00(R)	10.00	10.00	55.00	=	N/A	1.00 P/F

Note: L = Left side, R = Right side

Limit State Categories P/U = Permanent Unfavourable

P/F = Permanent Favourable

Var = Variable (unfavourable)

CONSTRUCTION STAGES

Construction stage no.	Stage description
1	Apply surcharge no.1 at elevation 49.75
2	Apply water pressure profile no.1 (Mod. Conserv.)
3	Excavate to elevation 47.90 on RIGHT side
4	Install strut or anchor no.1 at elevation 48.20
5	Apply water pressure profile no.2 (Mod. Conserv.)
6	Excavate to elevation 43.41 on RIGHT side
7	Fill to elevation 43.85 on RIGHT side with soil type 1
8	Install strut or anchor no.2 at elevation 44.05
9	Change EI of wall to 43355 kN.m ² /m run Yield moment not defined Allow wall to relax with new modulus value
10	Change properties of soil type 3 to soil type 4 Ko pressures will not be reset
11	Apply surcharge no.2 at elevation 43.85 No analysis at this stage
12	Apply water pressure profile no.3 (Mod. Conserv.)

FACTORS OF SAFETY and ANALYSIS OPTIONS

Limit State options: ULS DAL Combination 1

Water pressures : Moderately Conservative

Partial factor on C' = 1.000

Partial factor on Phi' = 1.000

Partial factor on Cu = 1.000

Partial factor on Soil Modulus = 1.000

Partial factor on Permanent Unfavourable loads = 1.000

Partial factor on Permanent Favourable loads = 1.000

Partial factor on Variable Unfavourable loads = 1.100

Design factor on calculated Bending Moments = 1.350

Parameters for undrained strata:

Minimum equivalent fluid density = 5.00 kN/m³

Maximum depth of water filled tension crack = 0.00 m

Bending moment and displacement calculation:

Method - Subgrade reaction model using Influence Coefficients

Open Tension Crack analysis? - No

Non-linear Modulus Parameter (L) = 9.000 m

Boundary conditions:

Length of wall (normal to plane of analysis) = 50.00 m

Width of excavation on Left side of wall = 50.00 m

Width of excavation on Right side of wall = 50.00 m

Distance to rigid boundary on Left side = 50.00 m

Distance to rigid boundary on Right side = 50.00 m

OUTPUT OPTIONS

Stage no.	Stage description	Output options		
		Displacement	Active, Graph.	Passive output
		Bending mom.	pressures	
		Shear force		
1	Apply surcharge no.1 at elev. 49.75	No	No	No
2	Apply water pressure profile no.1	Yes	Yes	Yes
3	Excav. to elev. 47.90 on RIGHT side	Yes	Yes	Yes
4	Install strut no.1 at elev. 48.20	Yes	Yes	Yes
5	Apply water pressure profile no.2	Yes	Yes	Yes
6	Excav. to elev. 43.41 on RIGHT side	Yes	Yes	Yes
7	Fill to elev. 43.85 on RIGHT side	Yes	Yes	Yes
8	Install strut no.2 at elev. 44.05	Yes	Yes	Yes
9	Change EI of wall to 43355kN.m2/m run	No	No	No
10	Change soil type 3 to soil type 4	No	No	No
11	Apply surcharge no.2 at elev. 43.85	No	No	No
12	Apply water pressure profile no.3	No	No	No
*	Summary output	Yes	-	Yes

Program WALLAP - Copyright (C) 2017 by DL Borin, distributed by GEOSOLVE
 150 St. Alphonsus Road, London SW4 7BW, UK www.geosolve.co.uk

Units: kN,m

Stage No.12 Apply water pressure profile no.3 (Mod. Conserv.)

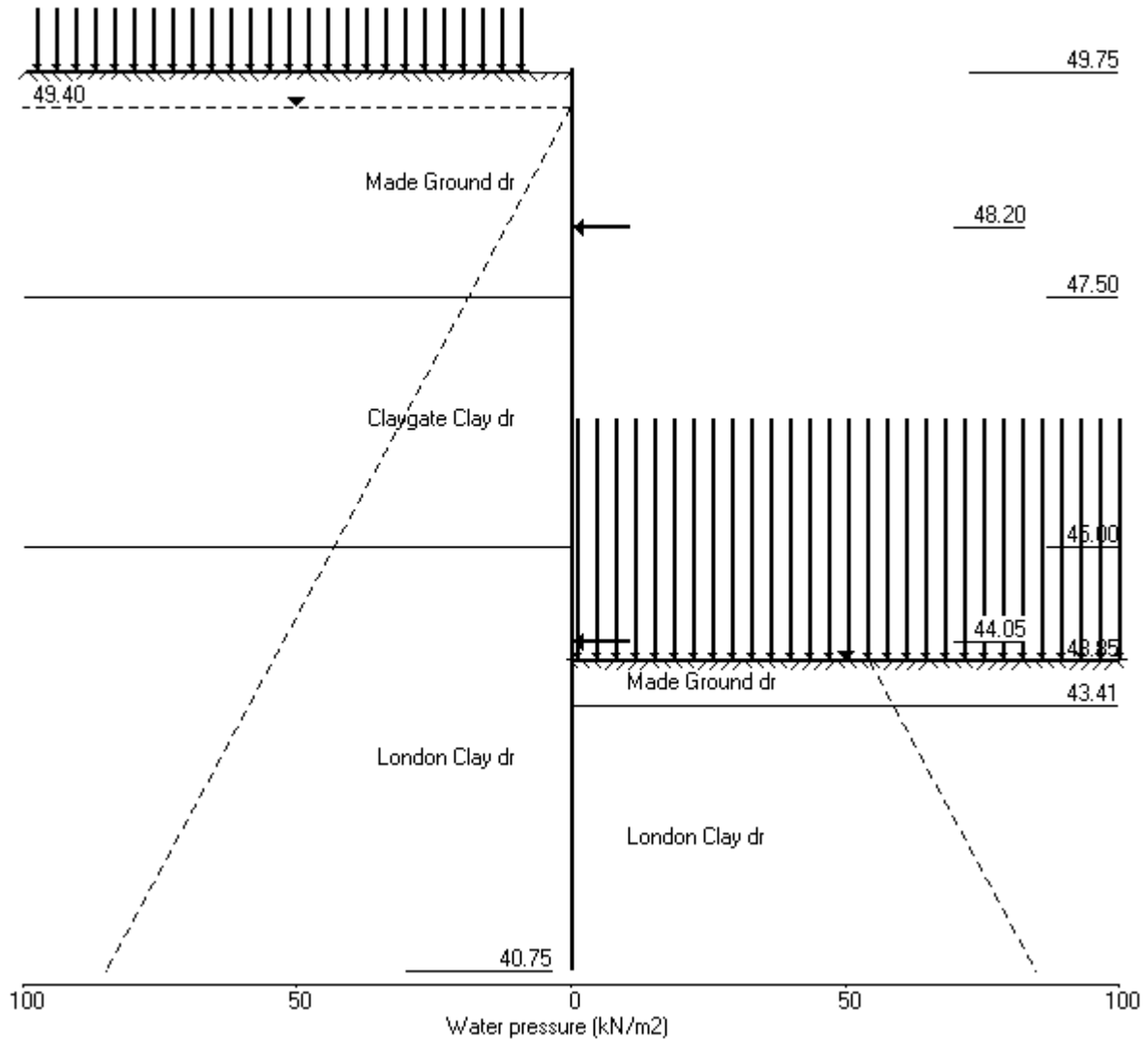

PILEDESIGNS LTD
 Program: WALLAP Version 6.06 Revision A51.B69.R54
 Licensed from GEOSOLVE
 Data filename/Run ID: Hampstead_Wall_2_450mm_rev_01_ULS1
 Hampstead - 24-26 Redington Gardens
 Wall 2, Secant-ULS1, 450 dia @ 650 - run 01

Sheet No.
 Job No. 21495
 Made by : DBS
 Date: 1-10-2018
 Checked :

Units: kN,m

Stage No. 3 Excavate to elevation 47.90 on RIGHT side

BENDING MOMENT and DISPLACEMENT ANALYSIS of Fully Embedded Wall

Analysis options

Length of wall perpendicular to section = 50.00m
 Subgrade reaction model - Boussinesq Influence coefficients
 Soil deformations are elastic until the active or passive limit is reached
 Open Tension Crack analysis - No

Rigid boundaries: Left side 50.00 from wall
 Right side 50.00 from wall

Limit State: ULS DA1 Combination 1

Calculated Bending Moments and Strut Forces are to be multiplied by a factor of 1.35 to obtain values for structural design. See summary for factored values.

Node no.	Y coord	Nett pressure kN/m2	Wall disp. m	Wall rotation rad.	Shear force kN/m	Bending moment kN.m/m	Strut forces kN/m	EI of wall kN.m2/m
1	49.75	0.00	0.012	2.67E-03	0.0	0.0		60696
2	49.40	2.55	0.011	2.67E-03	0.4	0.1		60696
3	49.10	7.21	0.010	2.67E-03	1.9	0.5		60696
4	48.80	11.71	0.009	2.66E-03	4.7	1.4		60696
5	48.50	15.99	0.008	2.65E-03	8.9	3.5		60696
6	48.20	20.11	0.007	2.62E-03	14.3	6.9		60696
7	47.90	24.12	0.007	2.58E-03	21.0	12.2		60696
8	47.50	4.57	0.006	2.46E-03	26.7	22.0		60696
		2.65	0.006	2.46E-03	26.7	22.0		
9	47.00	-12.50	0.004	2.23E-03	24.2	34.9		60696
10	46.50	-27.74	0.003	1.90E-03	14.2	44.8		60696
11	46.00	-29.49	0.003	1.51E-03	-0.1	49.9		60696
12	45.50	-14.96	0.002	1.12E-03	-11.2	46.1		60696
13	45.00	-5.21	0.001	7.73E-04	-16.3	38.6		60696
		-9.93	0.001	7.73E-04	-16.3	38.6		
14	44.53	0.02	0.001	5.05E-04	-18.6	29.7		60696
15	44.05	5.64	0.001	3.08E-04	-17.3	20.9		60696
16	43.85	6.97	0.001	2.44E-04	-16.0	17.5		60696
17	43.41	8.27	0.001	1.41E-04	-12.7	11.1		60696
18	43.00	8.05	0.001	8.12E-05	-9.3	6.6		60696
19	42.50	6.71	0.001	4.20E-05	-5.6	2.9		60696
20	42.00	4.80	0.001	2.62E-05	-2.8	0.9		60696
21	41.50	2.74	0.001	2.18E-05	-0.9	0.1		60696
22	41.13	1.18	0.001	2.15E-05	-0.1	-0.0		60696
23	40.75	-0.38	0.001	2.16E-05	0.0	-0.0		---

Node no.	Y coord	LEFT side					Total earth pressure kN/m2	Coeff. of subgrade reaction kN/m3
		Water press. kN/m2	Vertical kN/m2	Active limit kN/m2	Passive limit kN/m2	Earth pressure kN/m2		
1	49.75	0.00	0.00	0.00	0.00	0.00	0.00	3619
2	49.40	0.00	7.58	2.55	26.10	2.55	2.55a	3619
3	49.10	2.94	12.68	4.27	43.63	4.27	7.21a	3619
4	48.80	5.89	17.31	5.83	59.60	5.83	11.71a	3619
5	48.50	8.83	21.28	7.17	73.27	7.17	15.99a	3619
6	48.20	11.77	24.77	8.34	85.28	8.34	20.11a	3619
7	47.90	14.71	27.94	9.41	96.17	9.41	24.12a	3619
8	47.50	18.64	31.82	10.71	109.53	10.71	29.35a	3619
		18.64	31.82	10.26	116.04	10.26	28.90a	10445
9	47.00	23.54	36.81	11.87	134.24	11.87	35.42a	10445

(continued)

Stage No.3 Excavate to elevation 47.90 on RIGHT side

Node no.	Y coord	LEFT side					Total earth pressure	Coeff. of subgrade reaction
		Water press. kN/m2	Vertic -al kN/m2	Effective Active limit kN/m2	Effective Passive limit kN/m2	Earth pressure kN/m2		
10	46.50	28.45	41.53	13.40	151.47	13.40	41.85a	10445
11	46.00	33.35	46.08	14.87	168.06	22.95	56.30	10445
12	45.50	38.26	50.51	16.29	184.21	33.91	72.17	10445
13	45.00	43.16	54.86	17.70	200.06	42.81	85.97	10445
		Total>	98.02	23.75m	217.53	73.90	73.90	20133
14	44.53	Total>	107.24	26.12m	232.42	87.70	87.70	21089
15	44.05	Total>	116.42	28.50m	247.28	99.59	99.59	22046
16	43.85	Total>	120.28	29.50m	253.53	104.14	104.14	22448
17	43.41	Total>	128.76	31.70m	267.27	113.43	113.43	23334
18	43.00	Total>	136.66	33.75m	280.07	121.46	121.46	24160
19	42.50	Total>	146.29	36.25m	295.68	130.75	130.75	25166
20	42.00	Total>	155.92	38.75m	311.29	139.80	139.80	26173
21	41.50	Total>	165.56	41.25m	326.91	148.77	148.77	27180
22	41.13	Total>	172.80	43.13m	338.63	155.50	155.50	27935
23	40.75	Total>	177.45	45.00m	347.75	162.24	162.24	28690

Node no.	Y coord	RIGHT side					Total earth pressure	Coeff. of subgrade reaction
		Water press. kN/m2	Vertic -al kN/m2	Effective Active limit kN/m2	Effective Passive limit kN/m2	Earth pressure kN/m2		
1	49.75	0.00	0.00	0.00	0.00	0.00	0.00	0.0
2	49.40	0.00	0.00	0.00	0.00	0.00	0.00	0.0
3	49.10	0.00	0.00	0.00	0.00	0.00	0.00	0.0
4	48.80	0.00	0.00	0.00	0.00	0.00	0.00	0.0
5	48.50	0.00	0.00	0.00	0.00	0.00	0.00	0.0
6	48.20	0.00	0.00	0.00	0.00	0.00	0.00	0.0
7	47.90	0.00	0.00	0.00	0.00	0.00	0.00	0.0
		Total>	0.00	0.00	0.00	0.00	0.00	4872
8	47.50	0.00	7.20	2.42	24.78	24.78	24.78p	4872
		Total>	0.00	7.20	2.32	26.26	26.26p	14092
9	47.00	4.90	11.80	3.80	43.01	43.01	47.92p	14092
10	46.50	9.81	16.39	5.29	59.77	59.77	69.58p	14092
11	46.00	14.71	20.99	6.77	76.53	71.08	85.79	14092
12	45.50	19.62	25.58	8.25	93.29	67.51	87.13	14092
13	45.00	24.52	30.18	9.73	110.05	66.66	91.18	14092
		Total>	54.70	14.50m	174.21	83.83	83.83	26640
14	44.53	Total>	64.20	16.88m	189.39	87.67	87.67	27906
15	44.05	Total>	73.71	19.25m	204.57	93.95	93.95	29171
16	43.85	Total>	77.71	20.25m	210.96	97.17	97.17	29704
17	43.41	Total>	86.51	22.45m	225.02	105.16	105.16	30876
18	43.00	Total>	94.71	24.50m	238.12	113.40	113.40	31969
19	42.50	Total>	104.72	27.00m	254.10	124.05	124.05	33301
20	42.00	Total>	114.72	29.50m	270.08	135.00	135.00	34633
21	41.50	Total>	124.73	32.00m	286.07	146.03	146.03	35965
22	41.13	Total>	132.23	33.88m	298.05	154.32	154.32	36964
23	40.75	Total>	139.74	35.75m	310.04	162.62	162.62	37963

Note: 41.85a Soil pressure at active limit
69.58p Soil pressure at passive limit

Units: kN,m

Stage No.3 Excav. to elev. 47.90 on RIGHT side

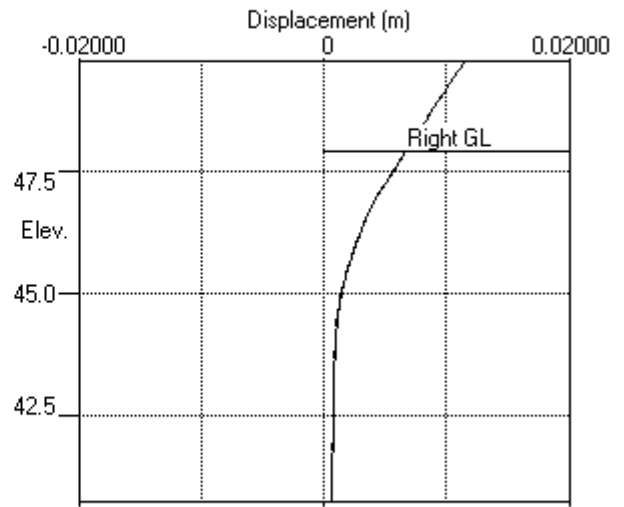
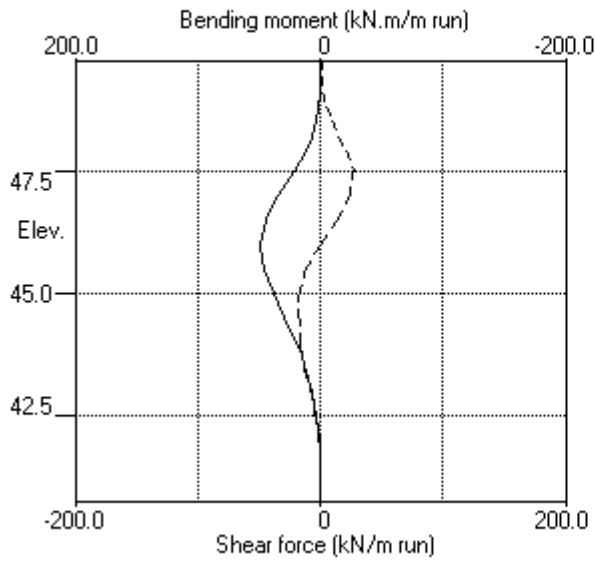

Stage No.3 Excav. to elev. 47.90 on RIGHT side

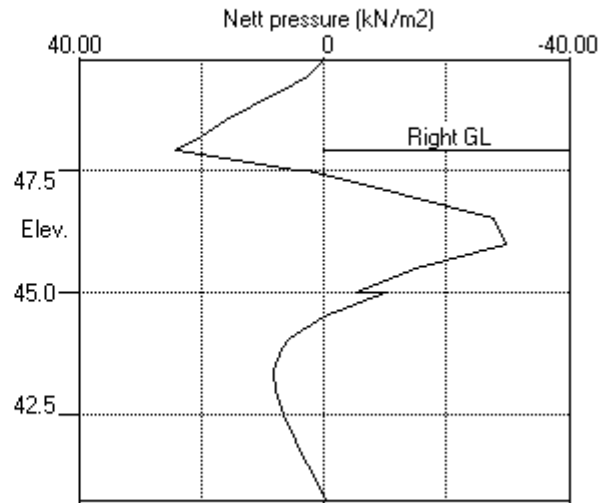
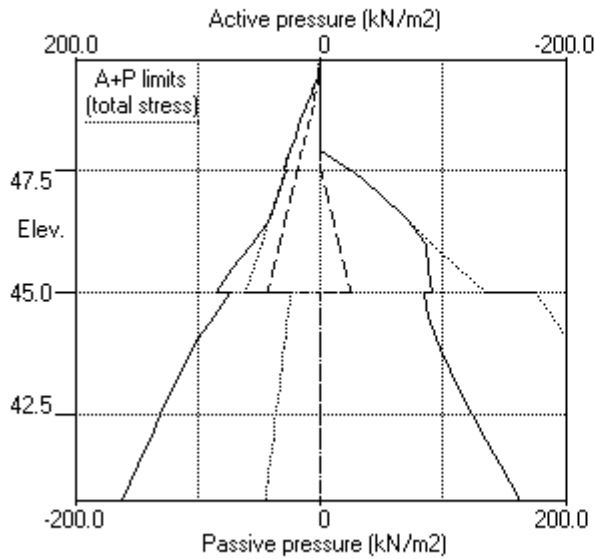

PILEDESIGNS LTD
 Program: WALLAP Version 6.06 Revision A51.B69.R54
 Licensed from GEOSOLVE
 Data filename/Run ID: Hampstead_Wall_2_450mm_rev_01_ULS1
 Hampstead - 24-26 Redington Gardens
 Wall 2, Secant-ULS1, 450 dia @ 650 - run 01

Sheet No.
 Job No. 21495
 Made by : DBS
 Date: 1-10-2018
 Checked :

Units: kN,m

Stage No. 6 Excavate to elevation 43.41 on RIGHT side

BENDING MOMENT and DISPLACEMENT ANALYSIS of Fully Embedded Wall

Analysis options

Length of wall perpendicular to section = 50.00m
 Subgrade reaction model - Boussinesq Influence coefficients
 Soil deformations are elastic until the active or passive limit is reached
 Open Tension Crack analysis - No

Rigid boundaries: Left side 50.00 from wall
 Right side 50.00 from wall

Limit State: ULS DA1 Combination 1

Calculated Bending Moments and Strut Forces are to be multiplied by a factor of 1.35 to obtain values for structural design. See summary for factored values.

Node no.	Y coord	Nett pressure kN/m2	Wall disp. m	Wall rotation rad.	Shear force kN/m	Bending moment kN.m/m	Strut forces kN/m	EI of wall kN.m2/m
1	49.75	0.00	0.005	-1.68E-03	0.0	0.0		60696
2	49.40	26.10	0.005	-1.69E-03	4.6	0.6		60696
3	49.10	33.33	0.006	-1.69E-03	13.5	2.9		60696
4	48.80	28.88	0.007	-1.72E-03	22.8	8.5		60696
5	48.50	24.13	0.007	-1.78E-03	30.8	16.7		60696
6	48.20	20.11	0.008	-1.89E-03	37.4	27.1	127.7	60696
		20.11	0.008	-1.89E-03	-90.3	27.1		
7	47.90	24.12	0.008	-1.96E-03	-83.7	1.0		60696
8	47.50	29.35	0.009	-1.86E-03	-73.0	-30.5		60696
		28.90	0.009	-1.86E-03	-73.0	-30.5		
9	47.00	35.42	0.010	-1.48E-03	-56.9	-63.1		60696
10	46.50	41.85	0.010	-8.66E-04	-37.6	-86.9		60696
11	46.00	48.22	0.011	-1.02E-04	-15.1	-98.6		60696
12	45.50	54.55	0.010	7.16E-04	10.6	-100.4		60696
13	45.00	60.86	0.010	1.49E-03	39.5	-88.5		60696
		23.75	0.010	1.49E-03	39.5	-88.5		
14	44.53	26.12	0.009	2.10E-03	51.3	-67.4		60696
15	44.05	28.50	0.008	2.52E-03	64.3	-40.3		60696
16	43.85	29.50	0.007	2.63E-03	70.1	-26.9		60696
17	43.41	31.70	0.006	2.70E-03	83.5	6.8		60696
		-106.80	0.006	2.70E-03	83.5	6.8		
18	43.00	-102.30	0.005	2.57E-03	40.7	34.1		60696
19	42.50	-74.81	0.004	2.23E-03	-3.6	46.7		60696
20	42.00	-29.06	0.003	1.89E-03	-29.6	35.5		60696
21	41.50	13.13	0.002	1.68E-03	-33.6	17.1		60696
22	41.13	44.24	0.001	1.61E-03	-22.8	5.4		60696
23	40.75	77.37	0.001	1.59E-03	0.0	-0.0		---

At elev. 48.20 Strut force = 127.7 kN/strut = 127.7 kN/m run

Node no.	Y coord	LEFT side						
		Effective stresses					Total earth pressure	Coeff. of subgrade reaction
		Water press.	Vertic -al	Active limit	Passive limit	Earth pressure		
		kN/m2	kN/m2	kN/m2	kN/m2	kN/m2	kN/m2	kN/m3
1	49.75	0.00	0.00	0.00	0.00	0.00	0.00	6816
2	49.40	0.00	7.58	2.55	26.10	26.10	26.10p	6816
3	49.10	2.94	12.68	4.27	43.63	30.39	33.33	6816
4	48.80	5.89	17.31	5.83	59.60	22.99	28.88	6816
5	48.50	8.83	21.28	7.17	73.27	15.30	24.13	6816
6	48.20	11.77	24.77	8.34	85.28	8.34	20.11a	2351
7	47.90	14.71	27.94	9.41	96.17	9.41	24.12a	2351

(continued)

Stage No.6 Excavate to elevation 43.41 on RIGHT side

Node no.	Y coord	LEFT side					Total earth pressure	Coeff. of subgrade reaction
		Water press. kN/m2	Vertic -al kN/m2	Effective Active limit kN/m2	Effective Passive limit kN/m2	Earth pressure kN/m2		
8	47.50	18.64	31.82	10.71	109.53	10.71	29.35a	2351
		18.64	31.82	10.26	116.04	10.26	28.90a	6753
9	47.00	23.54	36.81	11.87	134.24	11.87	35.42a	6753
10	46.50	28.45	41.53	13.40	151.47	13.40	41.85a	6753
11	46.00	33.35	46.08	14.87	168.06	14.87	48.22a	6753
12	45.50	38.26	50.51	16.29	184.21	16.29	54.55a	6753
13	45.00	43.16	54.86	17.70	200.06	17.70	60.86a	6753
		Total>	98.02	23.75m	217.53	23.75	23.75a	13621
14	44.53	Total>	107.24	26.12m	232.42	26.12	26.12a	14268
15	44.05	Total>	116.42	28.50m	247.28	28.50	28.50a	14915
16	43.85	Total>	120.28	29.50m	253.53	29.50	29.50a	15187
17	43.41	Total>	128.76	31.70m	267.27	31.70	31.70a	15787
18	43.00	Total>	136.66	33.75m	280.07	49.29	49.29	16345
19	42.50	Total>	146.29	36.25m	295.68	75.67	75.67	17026
20	42.00	Total>	155.92	38.75m	311.29	100.51	100.51	17707
21	41.50	Total>	165.56	41.25m	326.91	124.14	124.14	18388
22	41.13	Total>	172.80	43.13m	338.63	141.69	141.69	18899
23	40.75	Total>	177.45	45.00m	347.75	160.07	160.07	19410

Node no.	Y coord	RIGHT side					Total earth pressure	Coeff. of subgrade reaction
		Water press. kN/m2	Vertic -al kN/m2	Effective Active limit kN/m2	Effective Passive limit kN/m2	Earth pressure kN/m2		
1	49.75	0.00	0.00	0.00	0.00	0.00	0.00	0.0
2	49.40	0.00	0.00	0.00	0.00	0.00	0.00	0.0
3	49.10	0.00	0.00	0.00	0.00	0.00	0.00	0.0
4	48.80	0.00	0.00	0.00	0.00	0.00	0.00	0.0
5	48.50	0.00	0.00	0.00	0.00	0.00	0.00	0.0
6	48.20	0.00	0.00	0.00	0.00	0.00	0.00	0.0
7	47.90	0.00	0.00	0.00	0.00	0.00	0.00	0.0
8	47.50	0.00	0.00	0.00	0.00	0.00	0.00	0.0
9	47.00	0.00	0.00	0.00	0.00	0.00	0.00	0.0
10	46.50	0.00	0.00	0.00	0.00	0.00	0.00	0.0
11	46.00	0.00	0.00	0.00	0.00	0.00	0.00	0.0
12	45.50	0.00	0.00	0.00	0.00	0.00	0.00	0.0
13	45.00	0.00	0.00	0.00	0.00	0.00	0.00	0.0
14	44.53	0.00	0.00	0.00	0.00	0.00	0.00	0.0
15	44.05	0.00	0.00	0.00	0.00	0.00	0.00	0.0
16	43.85	0.00	0.00	0.00	0.00	0.00	0.00	0.0
17	43.41	0.00	0.00	0.00	0.00	0.00	0.00	0.0
		Total>	0.00	0.00	138.50	138.50	138.50p	32286
18	43.00	Total>	8.20	2.05m	151.60	151.60	151.60p	33428
19	42.50	Total>	18.20	4.55m	167.58	150.48	150.48	34821
20	42.00	Total>	28.20	7.05m	183.55	129.57	129.57	36213
21	41.50	Total>	38.20	9.55m	199.53	111.01	111.01	37606
22	41.13	Total>	45.70	11.42m	211.51	97.44	97.44	38651
23	40.75	Total>	53.21	13.30m	223.50	82.71	82.71	39696

Note: 31.70a Soil pressure at active limit
 151.60p Soil pressure at passive limit

Units: kN,m

Stage No.6 Excav. to elev. 43.41 on RIGHT side

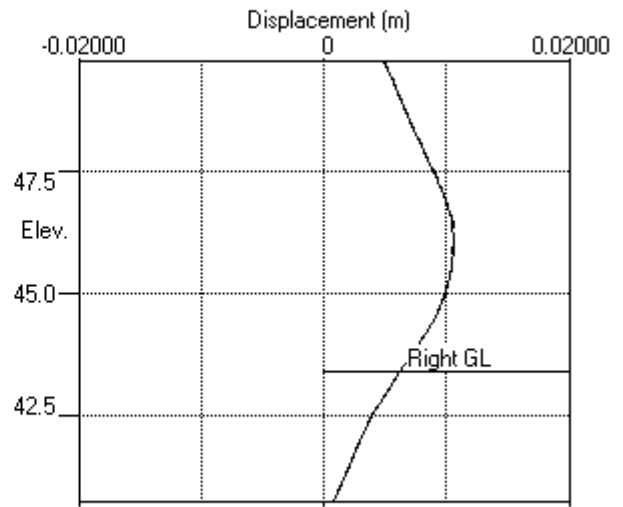
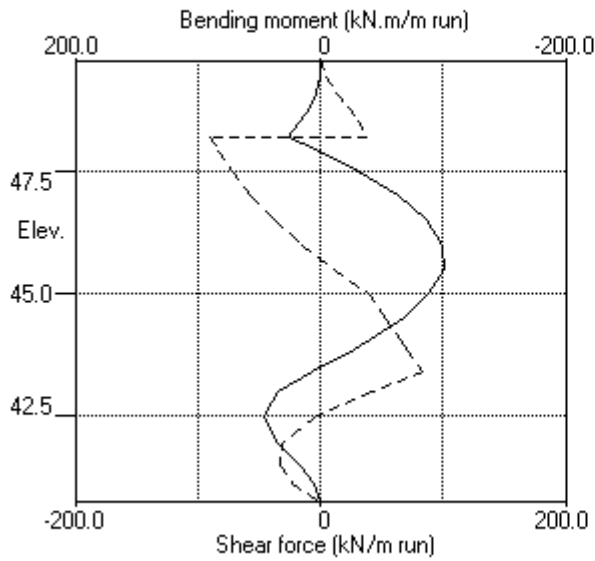

Stage No.6 Excav. to elev. 43.41 on RIGHT side

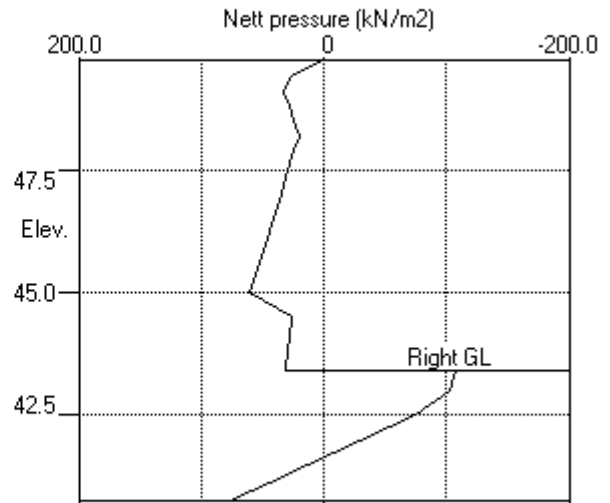
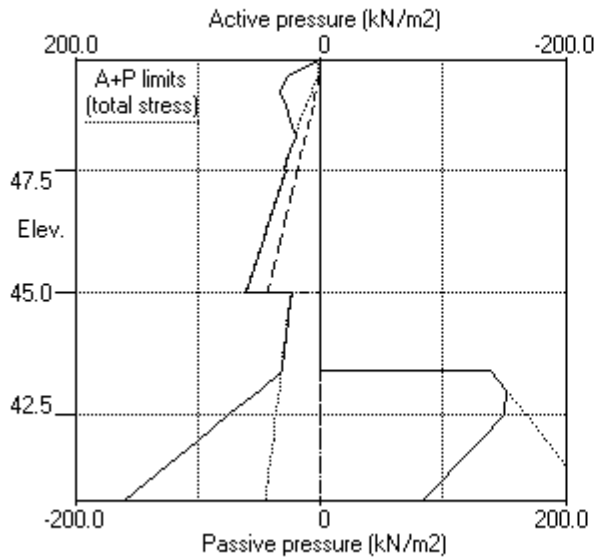

PILEDESIGNS LTD
 Program: WALLAP Version 6.06 Revision A51.B69.R54
 Licensed from GEOSOLVE
 Data filename/Run ID: Hampstead_Wall_2_450mm_rev_01_ULS1
 Hampstead - 24-26 Redington Gardens
 Wall 2, Secant-ULS1, 450 dia @ 650 - run 01

Sheet No.
 Job No. 21495
 Made by : DBS
 Date: 1-10-2018
 Checked :

Units: kN,m

Stage No. 7 Fill to elevation 43.85 on RIGHT side with soil type 1

BENDING MOMENT and DISPLACEMENT ANALYSIS of Fully Embedded Wall

Analysis options

Length of wall perpendicular to section = 50.00m
 Subgrade reaction model - Boussinesq Influence coefficients
 Soil deformations are elastic until the active or passive limit is reached
 Open Tension Crack analysis - No

Rigid boundaries: Left side 50.00 from wall
 Right side 50.00 from wall

Limit State: ULS DA1 Combination 1

Calculated Bending Moments and Strut Forces are to be multiplied by a factor of 1.35 to obtain values for structural design. See summary for factored values.

Node no.	Y coord	Nett pressure kN/m2	Wall disp. m	Wall rotation rad.	Shear force kN/m	Bending moment kN.m/m	Strut forces kN/m	EI of wall kN.m2/m
1	49.75	0.00	0.005	-1.68E-03	0.0	0.0		60696
2	49.40	26.06	0.005	-1.68E-03	4.6	0.6		60696
3	49.10	33.31	0.006	-1.69E-03	13.5	2.9		60696
4	48.80	28.86	0.007	-1.72E-03	22.8	8.5		60696
5	48.50	24.11	0.007	-1.78E-03	30.7	16.7		60696
6	48.20	20.11	0.008	-1.89E-03	37.4	27.1	128.1	60696
		20.11	0.008	-1.89E-03	-90.7	27.1		
7	47.90	24.12	0.008	-1.96E-03	-84.1	0.8		60696
8	47.50	29.36	0.009	-1.86E-03	-73.4	-30.7		60696
		28.93	0.009	-1.86E-03	-73.4	-30.7		
9	47.00	35.48	0.010	-1.47E-03	-57.3	-63.6		60696
10	46.50	41.96	0.010	-8.52E-04	-37.9	-87.6		60696
11	46.00	48.40	0.011	-8.21E-05	-15.3	-99.4		60696
12	45.50	54.83	0.010	7.44E-04	10.5	-101.3		60696
13	45.00	61.26	0.010	1.53E-03	39.5	-89.4		60696
		24.55	0.010	1.53E-03	39.5	-89.4		
14	44.53	27.27	0.009	2.14E-03	51.8	-68.2		60696
15	44.05	30.07	0.008	2.57E-03	65.4	-40.8		60696
16	43.85	31.27	0.007	2.68E-03	71.5	-27.1		60696
17	43.41	31.26	0.006	2.75E-03	85.3	7.3		60696
		-109.95	0.006	2.75E-03	85.3	7.3		
18	43.00	-104.59	0.005	2.61E-03	41.3	35.1		60696
19	42.50	-76.11	0.004	2.27E-03	-3.9	47.7		60696
20	42.00	-29.49	0.003	1.92E-03	-30.3	36.3		60696
21	41.50	13.49	0.002	1.70E-03	-34.3	17.5		60696
22	41.13	45.18	0.001	1.63E-03	-23.3	5.6		60696
23	40.75	78.88	0.001	1.61E-03	0.0	-0.0		---

At elev. 48.20 Strut force = 128.1 kN/strut = 128.1 kN/m run

Node no.	Y coord	LEFT side						
		Water press. kN/m2	Vertic -al kN/m2	Effective Active limit kN/m2	Effective Passive limit kN/m2	Earth pressure kN/m2	Total earth pressure kN/m2	Coeff. of subgrade reaction kN/m3
1	49.75	0.00	0.00	0.00	0.00	0.00	0.00	6432
2	49.40	0.00	7.58	2.55	26.10	26.06	26.06	6432
3	49.10	2.94	12.68	4.27	43.63	30.36	33.31	6432
4	48.80	5.89	17.31	5.83	59.60	22.97	28.86	6432
5	48.50	8.83	21.28	7.17	73.27	15.29	24.11	6432
6	48.20	11.77	24.77	8.34	85.28	8.34	20.11a	6432
7	47.90	14.71	27.94	9.41	96.17	9.41	24.12a	2815

(continued)

Stage No.7 Fill to elevation 43.85 on RIGHT side with soil type 1

Node no.	Y coord	LEFT side					Total earth pressure	Coeff. of subgrade reaction
		Water press. kN/m2	Vertic -al kN/m2	Effective Active limit kN/m2	Effective Passive limit kN/m2	Earth pressure kN/m2		
8	47.50	18.64	31.82	10.71	109.53	10.72	29.36	2815
		18.64	31.82	10.26	116.04	10.29	28.93	8105
9	47.00	23.54	36.81	11.87	134.24	11.93	35.48	8105
10	46.50	28.45	41.53	13.40	151.47	13.51	41.96	8105
11	46.00	33.35	46.08	14.87	168.06	15.04	48.40	8105
12	45.50	38.26	50.51	16.29	184.21	16.57	54.83	8105
13	45.00	43.16	54.86	17.70	200.06	18.10	61.26	8105
		Total>	98.02	23.75m	217.53	24.55	24.55	15984
14	44.53	Total>	107.24	26.12m	232.42	27.27	27.27	16743
15	44.05	Total>	116.42	28.50m	247.28	30.07	30.07	17502
16	43.85	Total>	120.28	29.50m	253.53	31.27	31.27	17822
17	43.41	Total>	128.76	31.70m	267.27	33.93	33.93	18525
18	43.00	Total>	136.66	33.75m	280.07	51.96	51.96	19180
19	42.50	Total>	146.29	36.25m	295.68	78.82	78.82	19980
20	42.00	Total>	155.92	38.75m	311.29	104.10	104.10	20779
21	41.50	Total>	165.56	41.25m	326.91	128.13	128.13	21578
22	41.13	Total>	172.80	43.13m	338.63	145.96	145.96	22177
23	40.75	Total>	177.45	45.00m	347.75	164.64	164.64	22777

Node no.	Y coord	RIGHT side					Total earth pressure	Coeff. of subgrade reaction
		Water press. kN/m2	Vertic -al kN/m2	Effective Active limit kN/m2	Effective Passive limit kN/m2	Earth pressure kN/m2		
1	49.75	0.00	0.00	0.00	0.00	0.00	0.00	0.0
2	49.40	0.00	0.00	0.00	0.00	0.00	0.00	0.0
3	49.10	0.00	0.00	0.00	0.00	0.00	0.00	0.0
4	48.80	0.00	0.00	0.00	0.00	0.00	0.00	0.0
5	48.50	0.00	0.00	0.00	0.00	0.00	0.00	0.0
6	48.20	0.00	0.00	0.00	0.00	0.00	0.00	0.0
7	47.90	0.00	0.00	0.00	0.00	0.00	0.00	0.0
8	47.50	0.00	0.00	0.00	0.00	0.00	0.00	0.0
9	47.00	0.00	0.00	0.00	0.00	0.00	0.00	0.0
10	46.50	0.00	0.00	0.00	0.00	0.00	0.00	0.0
11	46.00	0.00	0.00	0.00	0.00	0.00	0.00	0.0
12	45.50	0.00	0.00	0.00	0.00	0.00	0.00	0.0
13	45.00	0.00	0.00	0.00	0.00	0.00	0.00	0.0
14	44.53	0.00	0.00	0.00	0.00	0.00	0.00	0.0
15	44.05	0.00	0.00	0.00	0.00	0.00	0.00	0.0
16	43.85	0.00	0.00	0.00	0.00	0.00	0.00	0.0
		Total>	0.00	0.00	0.00	0.00	0.00	2815
17	43.41	0.00	7.92	2.67	27.26	2.67	2.67a	2815
		Total>	7.92	2.20m	146.42	143.88	143.88	18525
18	43.00	Total>	16.12	4.25m	159.52	156.55	156.55	19180
19	42.50	Total>	26.12	6.75m	175.50	154.94	154.94	19980
20	42.00	Total>	36.12	9.25m	191.48	133.59	133.59	20779
21	41.50	Total>	46.12	11.75m	207.45	114.64	114.64	21578
22	41.13	Total>	53.63	13.62m	219.44	100.78	100.78	22177
23	40.75	Total>	61.13	15.50m	231.42	85.76	85.76	22777

Note: 2.67a Soil pressure at active limit
123.45p Soil pressure at passive limit

Units: kN,m

Stage No.7 Fill to elev. 43.85 on RIGHT side

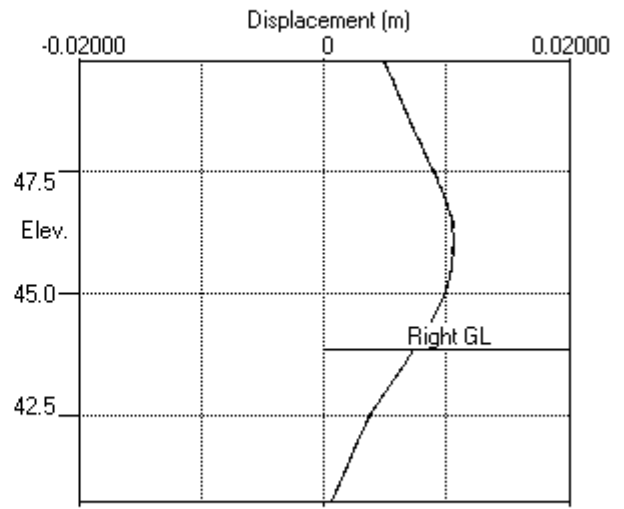
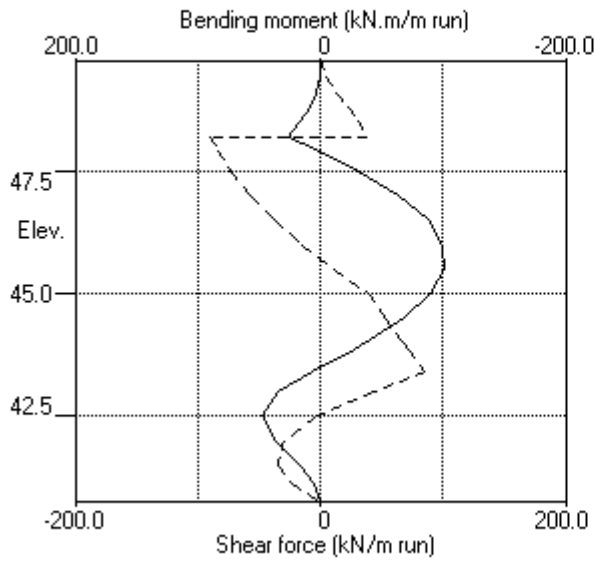

Stage No.7 Fill to elev. 43.85 on RIGHT side

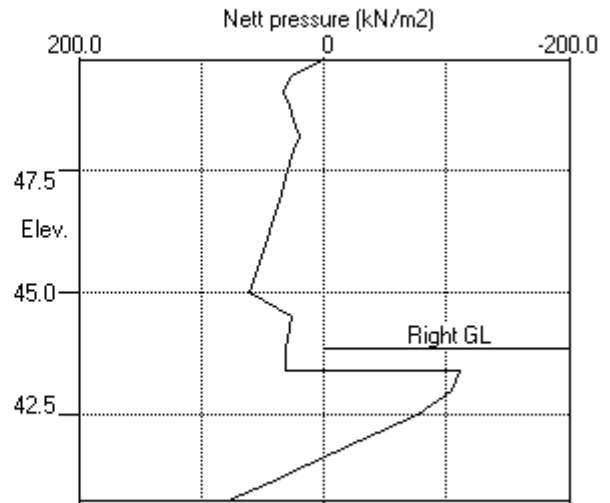
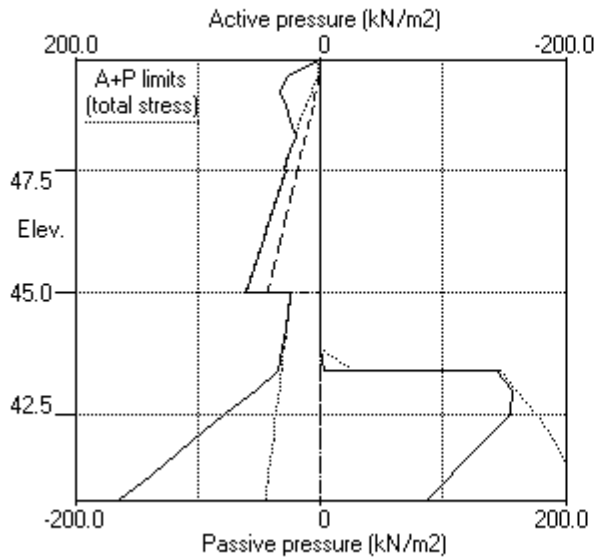

PILEDESIGNS LTD
 Program: WALLAP Version 6.06 Revision A51.B69.R54
 Licensed from GEOSOLVE
 Data filename/Run ID: Hampstead_Wall_2_450mm_rev_01_ULS1
 Hampstead - 24-26 Redington Gardens
 Wall 2, Secant-ULS1, 450 dia @ 650 - run 01

Sheet No.
 Job No. 21495
 Made by : DBS
 Date: 1-10-2018
 Checked :

Units: kN,m

Stage No. 9 Change EI of wall to 43355 kN.m²/m run
 Yield moment not defined
 Allow wall to relax with new modulus value

BENDING MOMENT and DISPLACEMENT ANALYSIS of Fully Embedded Wall

Analysis options

Length of wall perpendicular to section = 50.00m
 Subgrade reaction model - Boussinesq Influence coefficients
 Soil deformations are elastic until the active or passive limit is reached
 Open Tension Crack analysis - No

Rigid boundaries: Left side 50.00 from wall
 Right side 50.00 from wall

Limit State: ULS DA1 Combination 1

Calculated Bending Moments and Strut Forces are to be multiplied by a factor of 1.35 to obtain values for structural design. See summary for factored values.

Node no.	Y coord	Nett pressure kN/m ²	Wall disp. m	Wall rotation rad.	Shear force kN/m	Bending moment kN.m/m	Strut forces kN/m	EI of wall kN.m ² /m
1	49.75	0.00	0.004	-1.96E-03	0.0	0.0		43355
2	49.40	26.10	0.005	-1.96E-03	4.6	0.6		43355
3	49.10	35.14	0.006	-1.97E-03	13.8	2.9		43355
4	48.80	30.14	0.006	-2.01E-03	23.5	8.6		43355
5	48.50	24.81	0.007	-2.10E-03	31.8	17.0		43355
6	48.20	20.14	0.008	-2.26E-03	38.5	27.7	124.2	43355
		20.14	0.008	-2.26E-03	-85.7	27.7		
7	47.90	24.12	0.008	-2.36E-03	-79.1	2.6		43355
8	47.50	29.35	0.009	-2.26E-03	-68.4	-27.4		43355
		28.90	0.009	-2.26E-03	-68.4	-27.4		
9	47.00	35.42	0.010	-1.78E-03	-52.3	-58.3		43355
10	46.50	41.85	0.011	-1.00E-03	-33.0	-80.3		43355
11	46.00	48.22	0.011	-4.79E-05	-10.5	-90.2		43355
12	45.50	54.55	0.011	9.59E-04	15.2	-90.3		43355
13	45.00	60.86	0.010	1.88E-03	44.1	-76.6		43355
		23.75	0.010	1.88E-03	44.1	-76.6		
14	44.53	26.12	0.009	2.55E-03	55.9	-53.8		43355
15	44.05	29.59	0.008	2.93E-03	69.2	-24.8	21.4	43355
		29.59	0.008	2.93E-03	47.8	-24.8		
16	43.85	32.25	0.007	3.00E-03	54.0	-13.9		43355
17	43.41	35.13	0.006	2.97E-03	68.8	14.6		43355
		-102.22	0.006	2.97E-03	68.8	14.6		
18	43.00	-93.37	0.005	2.71E-03	28.7	37.6		43355
19	42.50	-63.77	0.004	2.22E-03	-10.6	46.4		43355
20	42.00	-19.48	0.003	1.77E-03	-31.4	33.5		43355
21	41.50	18.75	0.002	1.49E-03	-31.6	15.2		43355
22	41.13	46.08	0.001	1.41E-03	-19.4	4.4		43355
23	40.75	57.60	0.001	1.40E-03	0.0	-0.0		---
At elev. 48.20 Strut force =			124.2 kN/strut =		124.2 kN/m run			
At elev. 44.05 Strut force =			21.4 kN/strut =		21.4 kN/m run			

(continued)

Stage No.9 Change EI of wall to 43355 kN.m2/m run
Yield moment not defined
Allow wall to relax with new modulus value

Node no.	Y coord	LEFT side					Total earth pressure	Coeff. of subgrade reaction
		Water press.	Vertic -al	Effective Active limit	Effective Passive limit	Earth pressure		
		kN/m2	kN/m2	kN/m2	kN/m2	kN/m2	kN/m2	kN/m3
1	49.75	0.00	0.00	0.00	0.00	0.00	0.00	6425
2	49.40	0.00	7.58	2.55	26.10	26.10	26.10p	6425
3	49.10	2.94	12.68	4.27	43.63	32.20	35.14	6425
4	48.80	5.89	17.31	5.83	59.60	24.26	30.14	6425
5	48.50	8.83	21.28	7.17	73.27	15.98	24.81	6425
6	48.20	11.77	24.77	8.34	85.28	8.37	20.14	6425
7	47.90	14.71	27.94	9.41	96.17	9.41	24.12a	3048
8	47.50	18.64	31.82	10.71	109.53	10.71	29.35a	3048
		18.64	31.82	10.26	116.04	10.26	28.90a	8783
9	47.00	23.54	36.81	11.87	134.24	11.87	35.42a	8783
10	46.50	28.45	41.53	13.40	151.47	13.40	41.85a	8783
11	46.00	33.35	46.08	14.87	168.06	14.87	48.22a	8783
12	45.50	38.26	50.51	16.29	184.21	16.29	54.55a	8783
13	45.00	43.16	54.86	17.70	200.06	17.70	60.86a	8783
		Total>	98.02	23.75m	217.53	23.75	23.75a	17181
14	44.53	Total>	107.24	26.12m	232.42	26.12	26.12a	17998
15	44.05	Total>	116.42	28.50m	247.28	29.59	29.59	18814
16	43.85	Total>	120.28	29.50m	253.53	32.25	32.25	22987
17	43.41	Total>	128.76	31.70m	267.27	37.79	37.79	23894
18	43.00	Total>	136.66	33.75m	280.07	57.57	57.57	24739
19	42.50	Total>	146.29	36.25m	295.68	84.99	84.99	25770
20	42.00	Total>	155.92	38.75m	311.29	109.11	109.11	26801
21	41.50	Total>	165.56	41.25m	326.91	130.76	130.76	27831
22	41.13	Total>	172.80	43.13m	338.63	146.41	146.41	29794
23	40.75	Total>	177.45	45.00m	347.75	154.00	154.00	161810

Node no.	Y coord	RIGHT side					Total earth pressure	Coeff. of subgrade reaction
		Water press.	Vertic -al	Effective Active limit	Effective Passive limit	Earth pressure		
		kN/m2	kN/m2	kN/m2	kN/m2	kN/m2	kN/m2	kN/m3
1	49.75	0.00	0.00	0.00	0.00	0.00	0.00	0.0
2	49.40	0.00	0.00	0.00	0.00	0.00	0.00	0.0
3	49.10	0.00	0.00	0.00	0.00	0.00	0.00	0.0
4	48.80	0.00	0.00	0.00	0.00	0.00	0.00	0.0
5	48.50	0.00	0.00	0.00	0.00	0.00	0.00	0.0
6	48.20	0.00	0.00	0.00	0.00	0.00	0.00	0.0
7	47.90	0.00	0.00	0.00	0.00	0.00	0.00	0.0
8	47.50	0.00	0.00	0.00	0.00	0.00	0.00	0.0
9	47.00	0.00	0.00	0.00	0.00	0.00	0.00	0.0
10	46.50	0.00	0.00	0.00	0.00	0.00	0.00	0.0
11	46.00	0.00	0.00	0.00	0.00	0.00	0.00	0.0
12	45.50	0.00	0.00	0.00	0.00	0.00	0.00	0.0
13	45.00	0.00	0.00	0.00	0.00	0.00	0.00	0.0
14	44.53	0.00	0.00	0.00	0.00	0.00	0.00	0.0
15	44.05	0.00	0.00	0.00	0.00	0.00	0.00	0.0
16	43.85	0.00	0.00	0.00	0.00	0.00	0.00	0.0
		0.00	0.00	0.00	0.00	0.00	0.00	3712
17	43.41	0.00	7.92	2.67	27.26	2.67	2.67a	3712
		Total>	7.92	2.20m	146.42	140.01	140.01	23894
18	43.00	Total>	16.12	4.25m	159.52	150.94	150.94	24739
19	42.50	Total>	26.12	6.75m	175.50	148.77	148.77	25770

(continued)

Stage No.9 Change EI of wall to 43355 kN.m2/m run
 Yield moment not defined
 Allow wall to relax with new modulus value

Node no.	Y coord	----- RIGHT side -----						Total earth pressure	Coeff. of subgrade reaction
		Water press.	Vertic -al	Effective Active limit	Effective Passive limit	Earth pressure	Earth pressure		
		kN/m2	kN/m2	kN/m2	kN/m2	kN/m2	kN/m2	kN/m3	
20	42.00	Total>	36.12	9.25m	191.48	128.58	128.58	26801	
21	41.50	Total>	46.12	11.75m	207.45	112.01	112.01	27831	
22	41.13	Total>	53.63	13.62m	219.44	100.33	100.33	29794	
23	40.75	Total>	61.13	15.50m	231.42	96.40	96.40	161810	

Note: 2.67a Soil pressure at active limit
 26.10p Soil pressure at passive limit

Units: kN,m

Stage No.9 Change EI of wall to 43355kN.m2/m run

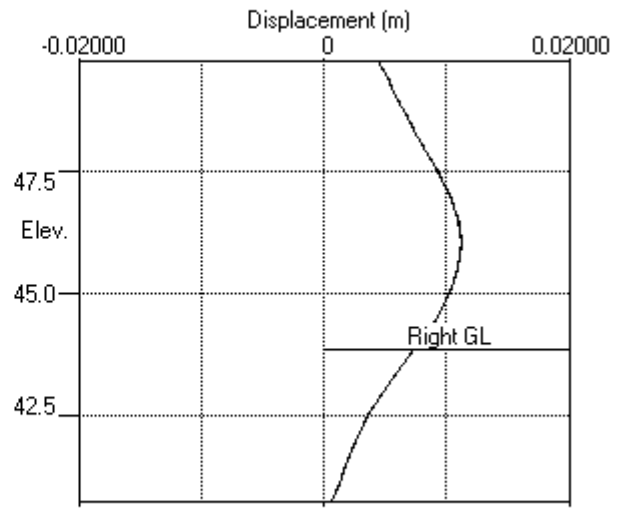
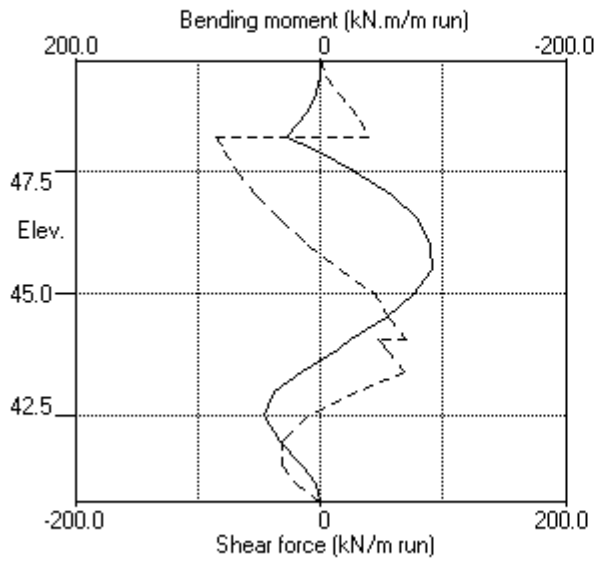

Stage No.9 Change EI of wall to 43355kN.m2/m run

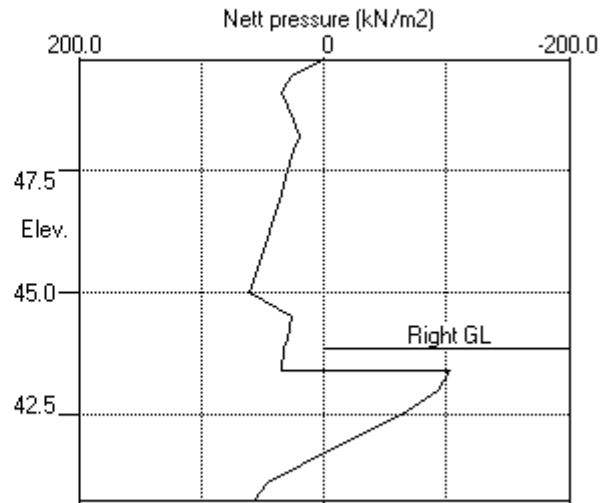
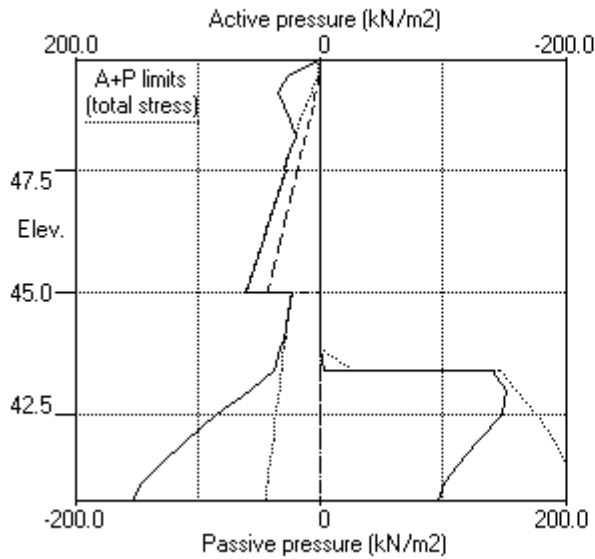

PILEDESIGNS LTD
 Program: WALLAP Version 6.06 Revision A51.B69.R54
 Licensed from GEOSOLVE
 Data filename/Run ID: Hampstead_Wall_2_450mm_rev_01_ULS1
 Hampstead - 24-26 Redington Gardens
 Wall 2, Secant-ULS1, 450 dia @ 650 - run 01

Sheet No.
 Job No. 21495
 Made by : DBS
 Date: 1-10-2018
 Checked :

Units: kN,m

Stage No. 10 Change properties of soil type 3 to soil type 4
 Ko pressures will not be reset

BENDING MOMENT and DISPLACEMENT ANALYSIS of Fully Embedded Wall

Analysis options

Length of wall perpendicular to section = 50.00m
 Subgrade reaction model - Boussinesq Influence coefficients
 Soil deformations are elastic until the active or passive limit is reached
 Open Tension Crack analysis - No

Rigid boundaries: Left side 50.00 from wall
 Right side 50.00 from wall

Limit State: ULS DA1 Combination 1

Calculated Bending Moments and Strut Forces are to be multiplied by a factor
 of 1.35 to obtain values for structural design. See summary for factored values.

Node no.	Y coord	Nett pressure kN/m ²	Wall disp. m	Wall rotation rad.	Shear force kN/m	Bending moment kN.m/m	Strut forces kN/m	EI of wall kN.m ² /m
1	49.75	0.00	0.005	-1.67E-03	0.0	0.0		43355
2	49.40	23.74	0.005	-1.67E-03	4.2	0.6		43355
3	49.10	33.38	0.006	-1.68E-03	12.7	2.7		43355
4	48.80	28.97	0.006	-1.72E-03	22.1	8.0		43355
5	48.50	24.24	0.007	-1.80E-03	30.1	15.9		43355
6	48.20	20.17	0.008	-1.95E-03	36.7	26.0	117.7	43355
		20.17	0.008	-1.95E-03	-81.0	26.0		
7	47.90	24.43	0.008	-2.05E-03	-74.3	2.4		43355
8	47.50	30.05	0.009	-1.95E-03	-63.4	-25.7		43355
		30.91	0.009	-1.95E-03	-63.4	-25.7		
9	47.00	38.73	0.010	-1.50E-03	-46.0	-53.9		43355
10	46.50	46.23	0.010	-8.00E-04	-24.8	-72.4		43355
11	46.00	53.26	0.011	3.79E-05	0.1	-77.6		43355
12	45.50	59.60	0.010	8.66E-04	28.3	-71.8		43355
13	45.00	64.97	0.010	1.53E-03	59.4	-50.9		43355
		62.43	0.010	1.53E-03	59.4	-50.9		
14	44.53	68.69	0.009	1.86E-03	90.6	-16.3		43355
15	44.05	74.94	0.008	1.71E-03	124.7	34.0	207.2	43355
		74.94	0.008	1.71E-03	-82.5	34.0		
16	43.85	77.57	0.008	1.57E-03	-67.2	19.8		43355
17	43.41	77.11	0.007	1.44E-03	-33.2	-0.7		43355
		57.59	0.007	1.44E-03	-33.2	-0.7		
18	43.00	36.30	0.007	1.46E-03	-14.0	-6.9		43355
19	42.50	21.38	0.006	1.53E-03	0.5	-5.1		43355
20	42.00	6.47	0.005	1.59E-03	7.4	-4.2		43355
21	41.50	-8.45	0.004	1.64E-03	6.9	-2.1		43355
22	41.13	-13.60	0.004	1.65E-03	2.8	0.2		43355
23	40.75	-1.29	0.003	1.65E-03	0.0	-0.0		---

At elev. 48.20 Strut force = 117.7 kN/strut = 117.7 kN/m run
 At elev. 44.05 Strut force = 207.2 kN/strut = 207.2 kN/m run

Node no.	Y coord	Water press. kN/m ²	Vertical -al kN/m ²	Effective Active limit kN/m ²	Passive limit kN/m ²	Earth pressure kN/m ²	Total earth pressure kN/m ²	Coeff. of subgrade reaction kN/m ³
1	49.75	0.00	0.00	0.00	0.00	0.00	0.00	6762
2	49.40	0.00	7.58	2.55	26.10	23.74	23.74	6762
3	49.10	2.94	12.68	4.27	43.63	30.44	33.38	6762
4	48.80	5.89	17.31	5.83	59.60	23.09	28.97	6762

(continued)

Stage No.10 Change properties of soil type 3 to soil type 4
Ko pressures will not be reset

Node no.	Y coord	LEFT side						Total earth pressure kN/m2	Coeff. of subgrade reaction kN/m3
		Water press. kN/m2	Vertic -al kN/m2	Effective stresses		Earth pressure kN/m2			
				Active limit kN/m2	Passive limit kN/m2				
5	48.50	8.83	21.28	7.17	73.27	15.41	24.24	6762	
6	48.20	11.77	24.77	8.34	85.28	8.39	20.17	3060	
7	47.90	14.71	27.94	9.41	96.17	9.72	24.43	3060	
8	47.50	18.64	31.82	10.71	109.53	11.41	30.05	3060	
		18.64	31.82	10.26	116.04	12.27	30.91	8819	
9	47.00	23.54	36.81	11.87	134.24	15.18	38.73	8819	
10	46.50	28.45	41.53	13.40	151.47	17.78	46.23	8819	
11	46.00	33.35	46.08	14.87	168.06	19.91	53.26	8819	
12	45.50	38.26	50.51	16.29	184.21	21.34	59.60	8819	
13	45.00	43.16	54.86	17.70	200.06	21.80	64.97	8819	
		43.16	54.86	19.27	178.44	19.27	62.43a	9054	
14	44.53	47.82	59.41	20.87	193.25	20.87	68.69a	9484	
15	44.05	52.48	63.93	22.46	207.96	22.46	74.94a	9992	
16	43.85	54.45	65.83	23.12	214.13	23.12	77.57a	10175	
17	43.41	58.76	70.00	24.59	227.68	24.59	83.35a	10576	
18	43.00	62.78	73.87	25.95	240.29	25.95	88.73a	10950	
19	42.50	67.69	78.60	27.61	255.66	27.61	95.30a	11407	
20	42.00	72.59	83.33	29.27	271.05	29.27	101.86a	11863	
21	41.50	77.50	88.07	30.93	286.46	30.93	108.43a	12319	
22	41.13	81.18	91.63	32.19	298.04	35.39	116.57	12661	
23	40.75	84.86	95.19	33.44	309.64	39.69	124.55	13004	

Node no.	Y coord	RIGHT side						Total earth pressure kN/m2	Coeff. of subgrade reaction kN/m3
		Water press. kN/m2	Vertic -al kN/m2	Effective stresses		Earth pressure kN/m2			
				Active limit kN/m2	Passive limit kN/m2				
1	49.75	0.00	0.00	0.00	0.00	0.00	0.00	0.0	
2	49.40	0.00	0.00	0.00	0.00	0.00	0.00	0.0	
3	49.10	0.00	0.00	0.00	0.00	0.00	0.00	0.0	
4	48.80	0.00	0.00	0.00	0.00	0.00	0.00	0.0	
5	48.50	0.00	0.00	0.00	0.00	0.00	0.00	0.0	
6	48.20	0.00	0.00	0.00	0.00	0.00	0.00	0.0	
7	47.90	0.00	0.00	0.00	0.00	0.00	0.00	0.0	
8	47.50	0.00	0.00	0.00	0.00	0.00	0.00	0.0	
9	47.00	0.00	0.00	0.00	0.00	0.00	0.00	0.0	
10	46.50	0.00	0.00	0.00	0.00	0.00	0.00	0.0	
11	46.00	0.00	0.00	0.00	0.00	0.00	0.00	0.0	
12	45.50	0.00	0.00	0.00	0.00	0.00	0.00	0.0	
13	45.00	0.00	0.00	0.00	0.00	0.00	0.00	0.0	
14	44.53	0.00	0.00	0.00	0.00	0.00	0.00	0.0	
15	44.05	0.00	0.00	0.00	0.00	0.00	0.00	0.0	
16	43.85	0.00	0.00	0.00	0.00	0.00	0.00	0.0	
		0.00	0.00	0.00	0.00	0.00	0.00	3084	
17	43.41	0.00	7.92	2.67	27.26	6.24	6.24	3084	
		0.00	7.92	2.78	25.76	25.76	25.76p	10576	
18	43.00	0.00	16.12	5.66	52.44	52.44	52.44p	10950	
19	42.50	4.90	21.22	7.45	69.01	69.01	73.92p	11407	
20	42.00	9.81	26.31	9.24	85.59	85.59	95.40p	11863	
21	41.50	14.71	31.41	11.03	102.17	102.17	116.88p	12319	
22	41.13	18.39	35.23	12.38	114.61	111.78	130.17	12661	
23	40.75	22.07	39.06	13.72	127.05	103.77	125.84	13004	

Run ID. Hampstead_Wall_2_450mm_rev_01_ULS1
Hampstead - 24-26 Redington Gardens
Wall 2, Secant-ULS1, 450 dia @ 650 - run 01

| Sheet No.
| Date: 1-10-2018
| Checked :

(continued)

Stage No.10 Change properties of soil type 3 to soil type 4
Ko pressures will not be reset
Note: 108.43a Soil pressure at active limit
116.88p Soil pressure at passive limit

Units: kN,m

Stage No.10 Change soil type 3 to soil type 4

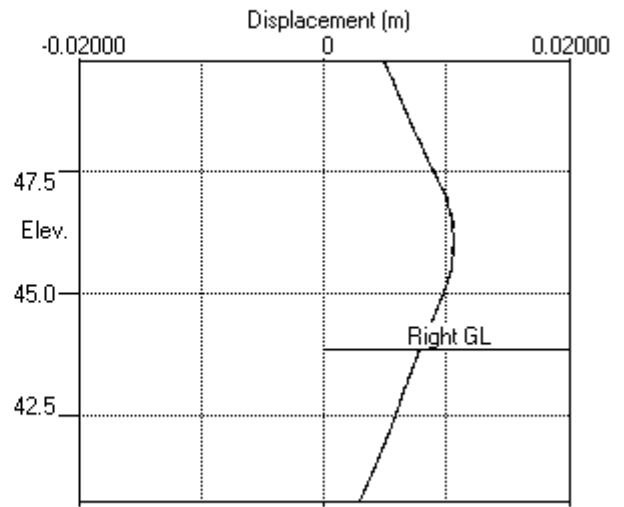
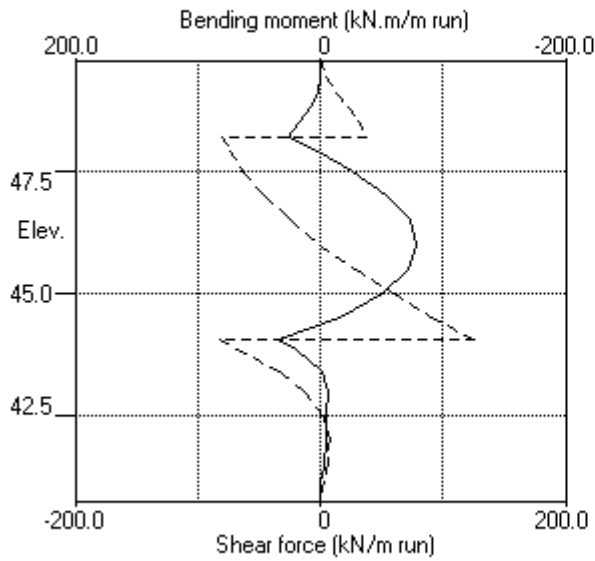

Stage No.10 Change soil type 3 to soil type 4

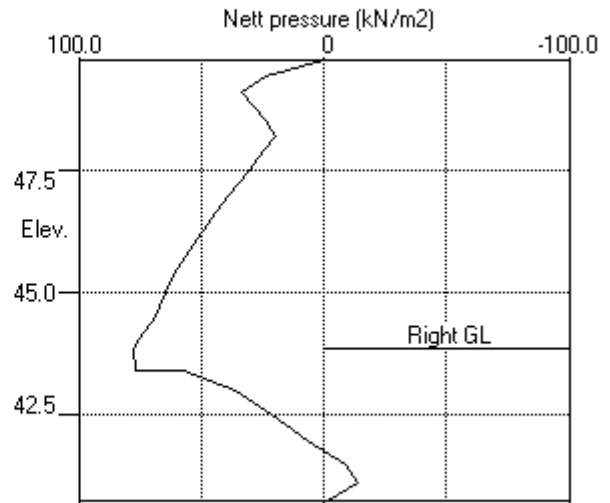
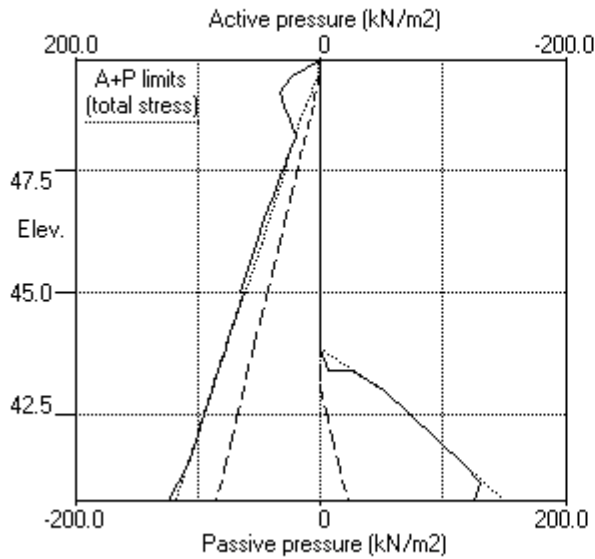

PILEDESIGNS LTD
 Program: WALLAP Version 6.06 Revision A51.B69.R54
 Licensed from GEOSOLVE
 Data filename/Run ID: Hampstead_Wall_2_450mm_rev_01_ULS1
 Hampstead - 24-26 Redington Gardens
 Wall 2, Secant-ULS1, 450 dia @ 650 - run 01

Sheet No.
 Job No. 21495
 Made by : DBS
 Date: 1-10-2018
 Checked :

Units: kN,m

Summary of results

BENDING MOMENT and DISPLACEMENT ANALYSIS of Fully Embedded Wall

Analysis options

Length of wall perpendicular to section = 50.00m
 Subgrade reaction model - Boussinesq Influence coefficients
 Soil deformations are elastic until the active or passive limit is reached
 Open Tension Crack analysis - No

Rigid boundaries: Left side 50.00 from wall
 Right side 50.00 from wall

Limit State: ULS DA1 Combination 1

Calculated Bending Moments and Strut Forces have been multiplied by a factor of 1.35 to obtain values for structural design.

Bending moment, shear force and displacement envelopes

Node no.	Y coord	Displacement		Bending moment				Shear force			
		max. m	min. m	Calculated kN.m/m		Factored kN.m/m		Calculated kN/m		Factored kN/m	
1	49.75	0.012	0.000	0	0	0	0	0	0	0	0
2	49.40	0.011	0.000	1	-0	1	-0	5	-1	6	-1
3	49.10	0.010	0.000	3	-0	4	-1	14	-2	19	-3
4	48.80	0.009	0.000	9	-1	12	-2	24	-3	32	-3
5	48.50	0.008	0.000	17	-2	23	-3	32	-2	43	-3
6	48.20	0.008	0.000	28	-3	37	-3	39	-91	52	-122
7	47.90	0.008	0.000	12	-3	16	-4	21	-84	28	-114
8	47.50	0.009	0.000	22	-31	30	-42	27	-73	36	-99
9	47.00	0.010	0.000	35	-64	47	-86	24	-57	33	-77
10	46.50	0.011	0.000	45	-88	60	-118	14	-38	19	-51
11	46.00	0.011	0.000	50	-99	67	-134	2	-15	2	-21
12	45.50	0.011	0.000	46	-101	62	-137	28	-11	38	-15
13	45.00	0.010	0.000	39	-89	52	-121	59	-16	80	-22
14	44.53	0.009	0.000	30	-68	40	-92	91	-19	122	-25
15	44.05	0.008	0.000	34	-41	46	-55	125	-82	168	-111
16	43.85	0.008	0.000	20	-27	27	-37	72	-67	97	-91
17	43.41	0.007	0.000	15	-1	20	-1	85	-33	115	-45
18	43.00	0.007	0.000	38	-7	51	-9	41	-14	56	-19
19	42.50	0.006	0.000	48	-5	64	-7	0	-11	1	-14
20	42.00	0.005	0.000	36	-4	49	-6	7	-31	10	-42
21	41.50	0.004	0.000	17	-2	24	-3	7	-34	9	-46
22	41.13	0.004	0.000	6	-0	7	-0	3	-23	4	-31
23	40.75	0.003	0.000	0	-0	0	-0	0	-0	0	-0

Summary of results (continued)

Calculated Bending Moments and Strut Forces have been multiplied by a factor of 1.35 to obtain values for structural design.

Maximum and minimum bending moment and shear force at each stage

Stage no.	Bending moment				Shear force			
	Calculated		Factored		Calculated		Factored	
min.	max. elev.	min. elev.	max. elev.	max. elev.	min. elev.	max. elev.	min. elev.	max. elev.
	kN.m/m	kN.m/m	kN.m/m	kN/m	kN/m	kN/m	kN/m	kN/m
1	2 43.41	-4 46.50	3 -5	4 45.00	-2 47.90	6		
-2	2 5 44.05	-3 47.90	6 -4	5 45.00	-3 48.80	7		
-3	3 50 46.00	-0 41.13	67 -0	27 47.50	-19 44.53	36		
-25	No calculation at this stage							
4	5 41 46.00	-0 40.75	56 -0	21 47.50	-14 44.05	28		
-19	6 47 42.50	-100 45.50	63 -136	84 43.41	-90 48.20	113		
-122	7 48 42.50	-101 45.50	64 -137	85 43.41	-91 48.20	115		
-122	No calculation at this stage							
8	9 46 42.50	-90 45.50	63 -122	69 44.05	-86 48.20	93		
-116	10 34 44.05	-78 46.00	46 -105	125 44.05	-82 44.05	168		
-111	No calculation at this stage							
11	12 27 48.20	-83 46.00	36 -112	118 44.05	-83 48.20	159		
-112								

Maximum and minimum displacement at each stage

Stage no.	Displacement				Stage description
	maximum	elev.	minimum	elev.	
	m		m		
1	0.001	47.90	0.000	49.75	Apply surcharge no.1 at elev. 49.75
2	0.002	49.75	0.000	49.75	Apply water pressure profile no.1
3	0.012	49.75	0.000	49.75	Excav. to elev. 47.90 on RIGHT side
4	No calculation at this stage				Install strut no.1 at elev. 48.20
5	0.011	49.75	0.000	49.75	Apply water pressure profile no.2
6	0.011	46.00	0.000	49.75	Excav. to elev. 43.41 on RIGHT side
7	0.011	46.00	0.000	49.75	Fill to elev. 43.85 on RIGHT side
8	No calculation at this stage				Install strut no.2 at elev. 44.05
9	0.011	46.00	0.000	49.75	Change EI of wall to 43355kN.m ² /m run
10	0.011	46.00	0.000	49.75	Change soil type 3 to soil type 4
11	No calculation at this stage				Apply surcharge no.2 at elev. 43.85
12	0.011	46.00	0.000	49.75	Apply water pressure profile no.3

Strut forces at each stage (horizontal components)

Stage no.	Strut no. 1			Strut no. 2		
	at elev. 48.20			at elev. 44.05		
	--Calculated--	Factored		--Calculated--	Factored	
	kN per m run	kN per strut	kN per strut	kN per m run	kN per strut	kN per strut
5	7	7	9	---	---	---
6	128	128	172	---	---	---
7	128	128	173	---	---	---
9	124	124	168	21	21	29
10	118	118	159	207	207	280
12	121	121	163	160	160	216

Units: kN,m

Bending moment, shear force, displacement envelopes

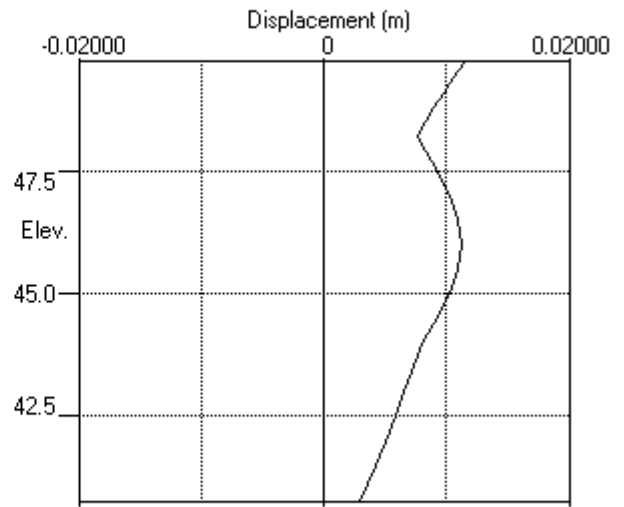
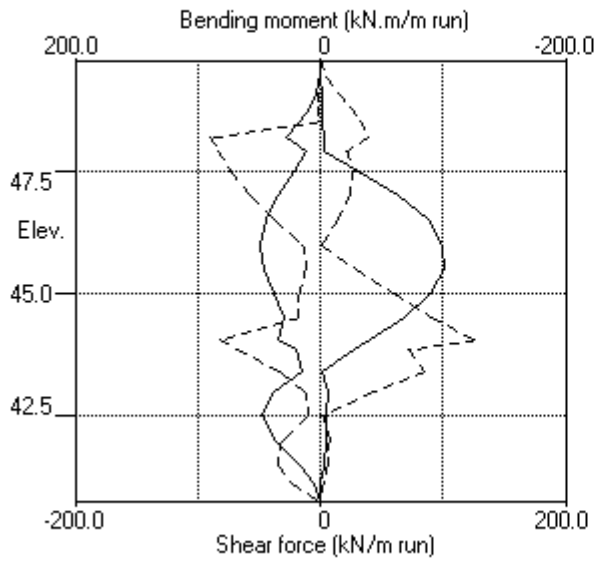



WALLAP

2-ULS2

PILEDESIGNS LTD
 Program: WALLAP Version 6.06 Revision A51.B69.R54
 Licensed from GEOSOLVE
 Data filename/Run ID: Hampstead_Wall_2_450mm_rev_01_ULS2
 Hampstead - 24-26 Redington Gardens
 Wall 2, Secant-ULS2, 450 dia @ 650 - run 01

Sheet No.
 Job No. 21495
 Made by : DBS
 Date: 1-10-2018
 Checked :

Units: kN,m

INPUT DATA

SOIL PROFILE

Stratum no.	Elevation of top of stratum	Soil types	
		Left side	Right side
1	49.75	1 Made Ground dr	1 Made Ground dr
2	47.50	2 Claygate Clay dr	2 Claygate Clay dr
3	45.00	3 London Clay und	3 London Clay und

SOIL PROPERTIES (Unfactored SLS soil strengths)

No. Description	Bulk density kN/m3	Young's Modulus Eh,kN/m2	At rest coeff. Ko	Consol state. NC/OC	Active limit Ka	Passive limit Kp	Cohesion kN/m2
(Datum elev.)		(dEh/dy)	(dKo/dy)	(Nu)	(Kac)	(Kpc)	(dc/dy)
1 Made Ground dr	18.00	10000	0.530	OC (0.250)	0.337 (0.000)	3.442 (0.000)	
2 Claygate Clay dr	19.00	30000	1.000	NC (0.200)	0.323 (1.330)	3.647 (5.195)	0.0d
3 London Cl.. (45.00)	20.00	40000 (4000)	1.000	OC (0.490)	1.000 (2.476)	1.000 (2.390)	50.00u (5.000)
4 London Cl.. (45.00)	20.00	30800 (3080)	1.000	OC (0.200)	0.351 (1.391)	3.253 (4.831)	0.0d

Additional soil parameters associated with Ka and Kp

No. Description	--- parameters for Ka ---			--- parameters for Kp ---		
	Soil friction angle	Wall adhesion coeff.	Back-fill angle	Soil friction angle	Wall adhesion coeff.	Back-fill angle
1 Made Ground dr	26.00	0.670	0.00	26.00	0.500	0.00
2 Claygate Clay dr	27.00	0.670	0.00	27.00	0.500	0.00
3 London Clay und	0.00	0.670	0.00	0.00	0.500	0.00
4 London Clay dr	25.00	0.670	0.00	25.00	0.500	0.00

GROUND WATER CONDITIONS

Density of water = 9.810 kN/m3

	Left side	Right side
Initial water table elevation	49.40	49.40

Automatic water pressure balancing at toe of wall : No

Water profile no.	Left side			Right side			
	Point no.	Elev. m	Piezo elev. m	Point no.	Elev. m	Piezo elev. m	Water press. kN/m2
1	1	49.40	49.40	1	47.50	47.50	0.0 MC+WC
2	1	49.40	49.40	1	43.00	43.00	0.0 MC+WC
3	1	49.40	49.40	1	43.85	43.85	0.0 MC+WC
				2	43.85	49.40	54.4

WALL PROPERTIES

Type of structure = Fully Embedded Wall
 Elevation of toe of wall = 40.75
 Maximum finite element length = 0.50 m
 Youngs modulus of wall E = 1.9600E+07 kN/m2
 Moment of inertia of wall I = 3.0968E-03 m4/m run
 E.I = 60696 kN.m2/m run
 Yield Moment of wall = Not defined

STRUTS and ANCHORS

Strut/ anchor no.	Elev.	Strut spacing m	X-section area of strut sq.m	Youngs modulus kN/m2	Free length m	Inclin -ation (degs)	Pre- stress /strut kN	Tension allowed
1	48.20	1.00	0.300000	1.400E+07	5.00	0.00	0	No
2	44.05	1.00	0.300000	1.400E+07	5.00	0.00	0	No

SURCHARGE LOADS

Surch -arge no.	Elev.	Distance from wall	Length parallel to wall	Width perpend. to wall	Surcharge ----- Near edge	Surcharge ----- Far edge	Equiv. soil type	Partial factor/ Category
1	49.75	0.50(L)	10.00	10.00	13.00	=	N/A	1.30 Var
2	43.85	-0.00(R)	10.00	10.00	55.00	=	N/A	1.00 P/F

Note: L = Left side, R = Right side

Limit State Categories P/U = Permanent Unfavourable
P/F = Permanent Favourable
Var = Variable (unfavourable)

CONSTRUCTION STAGES

Construction stage no.	Stage description
1	Apply surcharge no.1 at elevation 49.75
2	Apply water pressure profile no.1 (Worst Cred.)
3	Excavate to elevation 47.90 on RIGHT side
4	Install strut or anchor no.1 at elevation 48.20
5	Apply water pressure profile no.2 (Worst Cred.)
6	Excavate to elevation 43.41 on RIGHT side
7	Fill to elevation 43.85 on RIGHT side with soil type 1
8	Install strut or anchor no.2 at elevation 44.05
9	Change EI of wall to 43355 kN.m2/m run Yield moment not defined Allow wall to relax with new modulus value
10	Change properties of soil type 3 to soil type 4 Ko pressures will not be reset
11	Apply surcharge no.2 at elevation 43.85 No analysis at this stage
12	Apply water pressure profile no.3 (Worst Cred.)

FACTORS OF SAFETY and ANALYSIS OPTIONS

Limit State options: ULS DA1 Combination 2

Water pressures : Worst Credible

Partial factor on C' = 1.250

Partial factor on Phi' = 1.250

Partial factor on Cu = 1.400

Partial factor on Soil Modulus = 1.000

Partial factor on Permanent Unfavourable loads = 1.000

Partial factor on Permanent Favourable loads = 1.000

Partial factor on Variable Unfavourable loads = 1.300

Stability analysis:

Method of analysis - Strength Factor method

Overall factor on soil strength for calculating wall depth = 1.00

Parameters for undrained strata:

Minimum equivalent fluid density = 5.00 kN/m3

Maximum depth of water filled tension crack = 0.00 m

Bending moment and displacement calculation:

Method - Subgrade reaction model using Influence Coefficients

Open Tension Crack analysis? - No

Non-linear Modulus Parameter (L) = 9.000 m

Boundary conditions:

Length of wall (normal to plane of analysis) = 50.00 m

Width of excavation on Left side of wall = 50.00 m

Width of excavation on Right side of wall = 50.00 m

Distance to rigid boundary on Left side = 50.00 m

Distance to rigid boundary on Right side = 50.00 m

OUTPUT OPTIONS

Stage no.	Stage description	Output options		
		Displacement	Active, Graph.	
		Bending mom.	Passive	output
		Shear force	pressures	
1	Apply surcharge no.1 at elev. 49.75	No	No	No
2	Apply water pressure profile no.1	Yes	Yes	Yes
3	Excav. to elev. 47.90 on RIGHT side	Yes	Yes	Yes
4	Install strut no.1 at elev. 48.20	Yes	Yes	Yes
5	Apply water pressure profile no.2	Yes	Yes	Yes
6	Excav. to elev. 43.41 on RIGHT side	Yes	Yes	Yes
7	Fill to elev. 43.85 on RIGHT side	Yes	Yes	Yes
8	Install strut no.2 at elev. 44.05	Yes	Yes	Yes
9	Change EI of wall to 43355kN.m ² /m run	No	No	No
10	Change soil type 3 to soil type 4	No	No	No
11	Apply surcharge no.2 at elev. 43.85	No	No	No
12	Apply water pressure profile no.3	No	No	No
*	Summary output	Yes	-	Yes

Program WALLAP - Copyright (C) 2017 by DL Borin, distributed by GEOSOLVE
 150 St. Alphonsus Road, London SW4 7BW, UK www.geosolve.co.uk

Units: kN,m

Stage No.12 Apply water pressure profile no.3 (Worst Cred.)

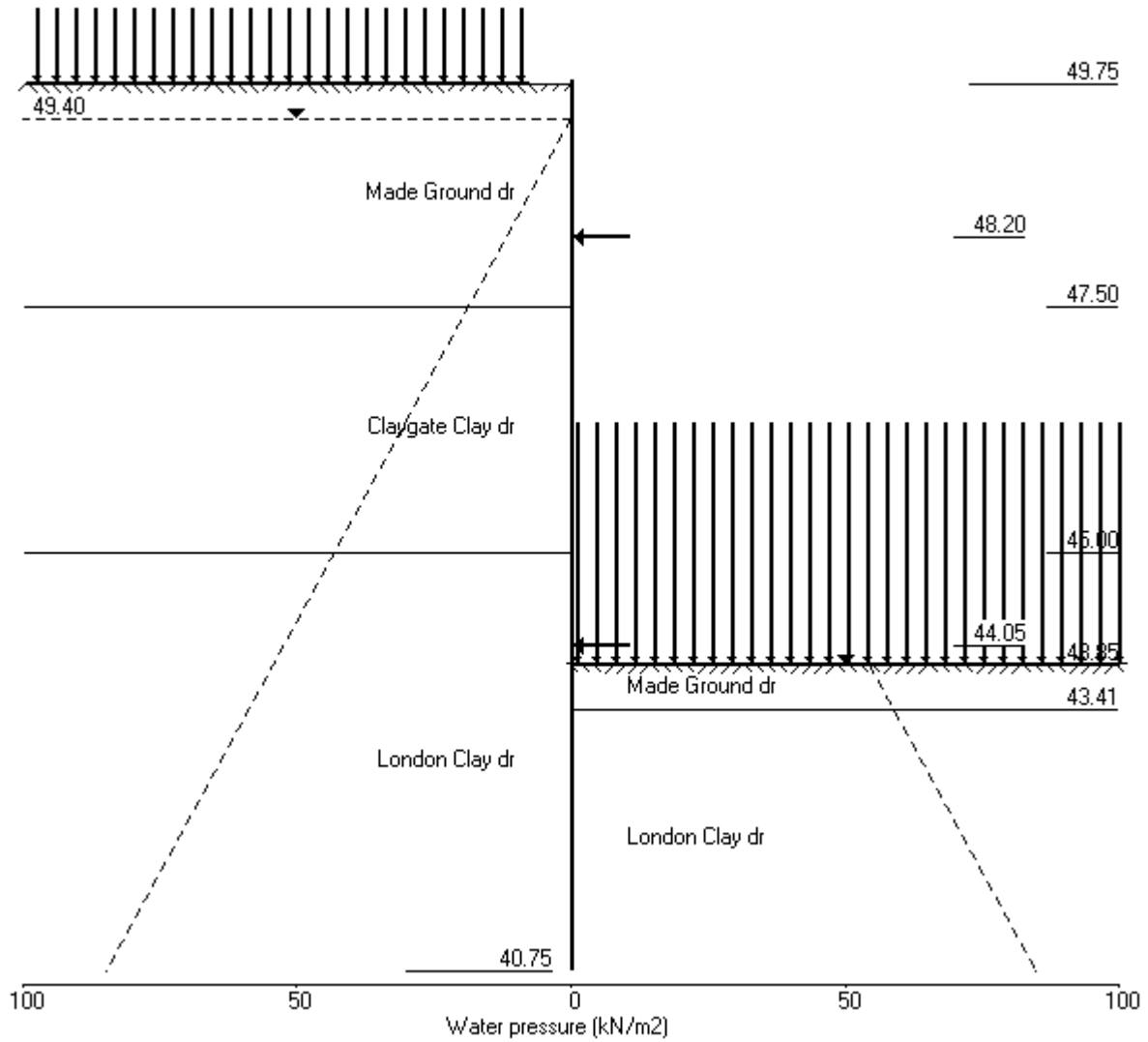

PILEDESIGNS LTD
 Program: WALLAP Version 6.06 Revision A51.B69.R54
 Licensed from GEOSOLVE
 Data filename/Run ID: Hampstead_Wall_2_450mm_rev_01_ULS2
 Hampstead - 24-26 Redington Gardens
 Wall 2, Secant-ULS2, 450 dia @ 650 - run 01

Sheet No.
 Job No. 21495
 Made by : DBS
 Date: 1-10-2018
 Checked :

Units: kN,m

Stage No. 3 Excavate to elevation 47.90 on RIGHT side

STABILITY ANALYSIS of Fully Embedded Wall according to Strength Factor method
 Factor of safety on soil strength

			Overall					
			FoS for toe		Toe elev. for			
			elev. = 40.75		FoS = 1.000			

Stage No.	--- G.L. Act.	--- Pass.	Strut Elev.	Factor of Safety	Moment of equil. at elev.	Toe elev.	Wall Penetr-ation	Direction of failure
3	49.75	47.90	Cant.	1.642	41.78	43.15	4.75	L to R

BENDING MOMENT and DISPLACEMENT ANALYSIS of Fully Embedded Wall

Analysis options

Length of wall perpendicular to section = 50.00m

Subgrade reaction model - Boussinesq Influence coefficients

Soil deformations are elastic until the active or passive limit is reached

Open Tension Crack analysis - No

Rigid boundaries: Left side 50.00 from wall

Right side 50.00 from wall

Limit State: ULS DA1 Combination 2

Node no.	Y coord	Nett pressure kN/m2	Wall disp. m	Wall rotation rad.	Shear force kN/m	Bending moment kN.m/m	Strut forces kN/m	EI of wall kN.m2/m
1	49.75	0.00	0.023	5.03E-03	0.0	-0.0		60696
2	49.40	3.21	0.022	5.03E-03	0.6	0.2		60696
3	49.10	8.43	0.020	5.03E-03	2.3	0.6		60696
4	48.80	13.44	0.019	5.02E-03	5.6	1.7		60696
5	48.50	18.13	0.017	5.01E-03	10.3	4.1		60696
6	48.20	22.58	0.016	4.98E-03	16.4	8.0		60696
7	47.90	26.87	0.014	4.93E-03	23.8	14.0		60696
8	47.50	13.25	0.012	4.80E-03	31.9	25.4		60696
		11.87	0.012	4.80E-03	31.9	25.4		
9	47.00	1.06	0.010	4.52E-03	35.1	42.2		60696
10	46.50	-9.87	0.008	4.10E-03	32.9	59.3		60696
11	46.00	-20.88	0.006	3.55E-03	25.2	74.0		60696
12	45.50	-31.96	0.004	2.90E-03	12.0	83.4		60696
13	45.00	-31.33	0.003	2.20E-03	-3.8	87.2		60696
		-63.21	0.003	2.20E-03	-3.8	87.2		
14	44.53	-30.25	0.002	1.55E-03	-26.0	78.3		60696
15	44.05	-7.18	0.001	1.00E-03	-34.9	62.5		60696
16	43.85	-0.20	0.001	8.12E-04	-35.6	55.3		60696
17	43.41	10.24	0.001	4.68E-04	-33.4	39.6		60696
18	43.00	15.04	0.001	2.43E-04	-28.2	26.8		60696
19	42.50	16.39	0.001	7.35E-05	-20.4	14.5		60696
20	42.00	14.66	0.001	-1.24E-05	-12.6	6.4		60696
21	41.50	11.29	0.001	-4.62E-05	-6.1	1.9		60696
22	41.13	8.27	0.001	-5.31E-05	-2.5	0.3		60696
23	40.75	4.88	0.001	-5.41E-05	0.0	-0.0		---

(continued)

Stage No.3 Excavate to elevation 47.90 on RIGHT side

Node no.	Y coord	LEFT side					Total earth pressure kN/m2	Coeff. of subgrade reaction kN/m3
		Water press. kN/m2	Vertic -al kN/m2	Effective Active limit kN/m2	Effective Passive limit kN/m2	Earth pressure kN/m2		
1	49.75	0.00	0.00	0.00	0.00	0.00	0.00	3377
2	49.40	0.00	7.81	3.21	20.81	3.21	3.21a	3377
3	49.10	2.94	13.39	5.49	35.66	5.49	8.43a	3377
4	48.80	5.89	18.42	7.56	49.07	7.56	13.44a	3377
5	48.50	8.83	22.67	9.30	60.38	9.30	18.13a	3377
6	48.20	11.77	26.35	10.81	70.18	10.81	22.58a	3377
7	47.90	14.71	29.64	12.16	78.95	12.16	26.87a	3377
8	47.50	18.64	33.63	13.79	89.58	13.79	32.43a	3377
		18.64	33.63	13.31	93.76	13.31	31.94a	9741
9	47.00	23.54	38.69	15.31	107.87	15.31	38.85a	9741
10	46.50	28.45	43.44	17.19	121.11	17.19	45.64a	9741
11	46.00	33.35	47.98	18.98	133.77	18.98	52.34a	9741
12	45.50	38.26	52.38	20.72	146.03	20.72	58.98a	9741
13	45.00	43.16	56.68	22.43	158.02	32.04	75.20	9741
		Total>	99.85	23.75m	185.21	51.15	51.15	18881
14	44.53	Total>	109.01	26.12m	198.43	75.07	75.07	19778
15	44.05	Total>	118.13	28.50m	211.61	94.62	94.62	20675
16	43.85	Total>	121.96	29.50m	217.15	101.65	101.65	21052
17	43.41	Total>	130.39	31.70m	229.33	114.93	114.93	21883
18	43.00	Total>	138.23	33.75m	240.67	125.12	125.12	22657
19	42.50	Total>	147.79	37.23	254.51	135.55	135.55	23601
20	42.00	Total>	157.36	42.37	268.34	144.64	144.64	24545
21	41.50	Total>	166.94	47.53	282.19	152.99	152.99	25490
22	41.13	Total>	174.13	51.40	292.58	159.05	159.05	26198
23	40.75	Total>	178.26	52.21	299.91	164.92	164.92	26906

Node no.	Y coord	RIGHT side					Total earth pressure kN/m2	Coeff. of subgrade reaction kN/m3
		Water press. kN/m2	Vertic -al kN/m2	Effective Active limit kN/m2	Effective Passive limit kN/m2	Earth pressure kN/m2		
1	49.75	0.00	0.00	0.00	0.00	0.00	0.00	0.0
2	49.40	0.00	0.00	0.00	0.00	0.00	0.00	0.0
3	49.10	0.00	0.00	0.00	0.00	0.00	0.00	0.0
4	48.80	0.00	0.00	0.00	0.00	0.00	0.00	0.0
5	48.50	0.00	0.00	0.00	0.00	0.00	0.00	0.0
6	48.20	0.00	0.00	0.00	0.00	0.00	0.00	0.0
7	47.90	0.00	0.00	0.00	0.00	0.00	0.00	0.0
		0.00	0.00	0.00	0.00	0.00	0.00	4424
8	47.50	0.00	7.20	2.95	19.18	19.18	19.18p	4424
		0.00	7.20	2.85	20.07	20.07	20.07p	12788
9	47.00	4.90	11.80	4.67	32.88	32.88	37.79p	12788
10	46.50	9.81	16.39	6.48	45.70	45.70	55.51p	12788
11	46.00	14.71	20.99	8.30	58.51	58.51	73.22p	12788
12	45.50	19.62	25.58	10.12	71.32	71.32	90.94p	12788
13	45.00	24.52	30.18	11.94	84.13	82.00	106.52	12788
		Total>	54.70	14.50m	140.07	114.37	114.37	24312
14	44.53	Total>	64.20	16.88m	153.62	105.32	105.32	25466
15	44.05	Total>	73.71	19.25m	167.18	101.80	101.80	26621
16	43.85	Total>	77.71	20.25m	172.89	101.84	101.84	27107
17	43.41	Total>	86.51	22.45m	185.45	104.68	104.68	28177
18	43.00	Total>	94.71	24.50m	197.15	110.08	110.08	29174
19	42.50	Total>	104.72	27.00m	211.42	119.17	119.17	30389
20	42.00	Total>	114.72	29.50m	225.70	129.97	129.97	31605

(continued)

Stage No.3 Excavate to elevation 47.90 on RIGHT side

Node no.	Y coord	----- RIGHT side -----					Total earth pressure	Coeff. of subgrade reaction
		Water press. kN/m2	Vertical	Effective Active limit	Effective Passive limit	Earth pressure kN/m2		
21	41.50	Total>	124.73	32.00m	239.97	141.70	141.70	32821
22	41.13	Total>	132.23	33.88m	250.68	150.77	150.77	33732
23	40.75	Total>	139.74	35.75m	261.39	160.05	160.05	34644

Note: 58.98a Soil pressure at active limit
 90.94p Soil pressure at passive limit

Units: kN,m

Stage No.3 Excav. to elev. 47.90 on RIGHT side

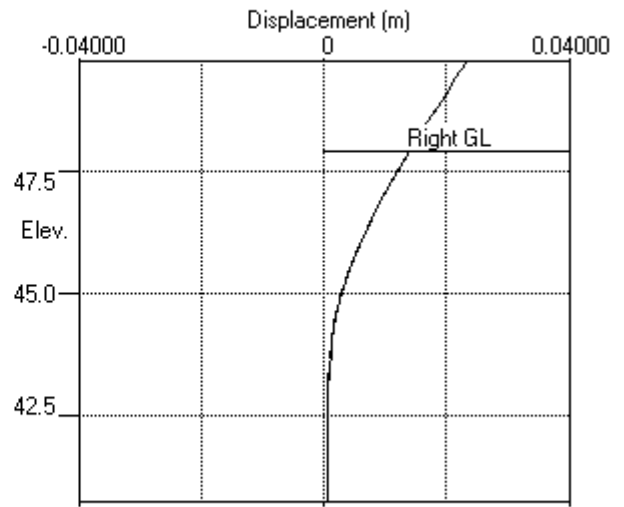
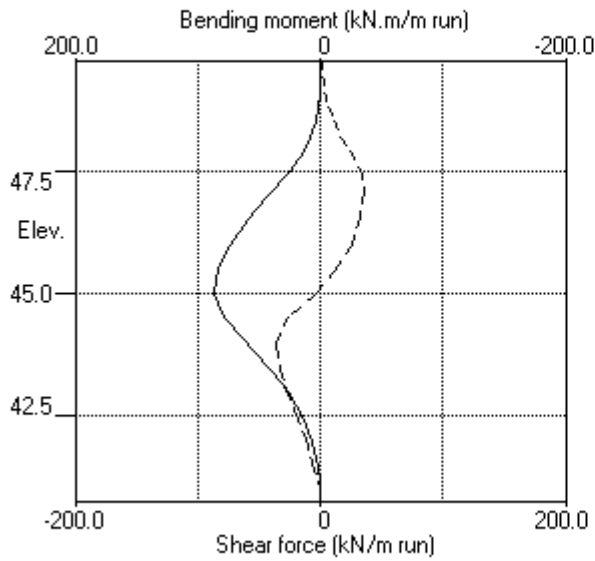

Stage No.3 Excav. to elev. 47.90 on RIGHT side

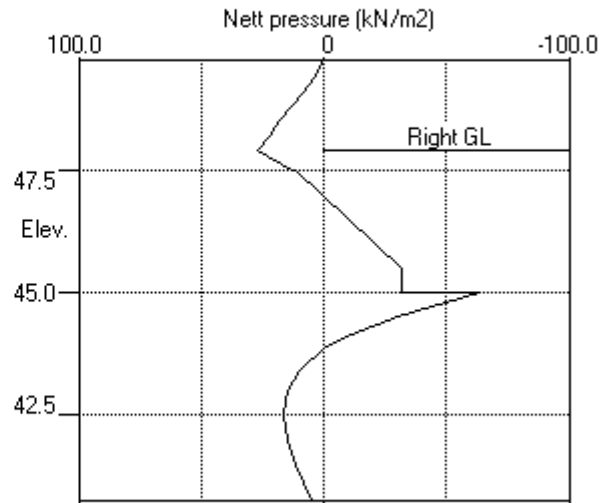
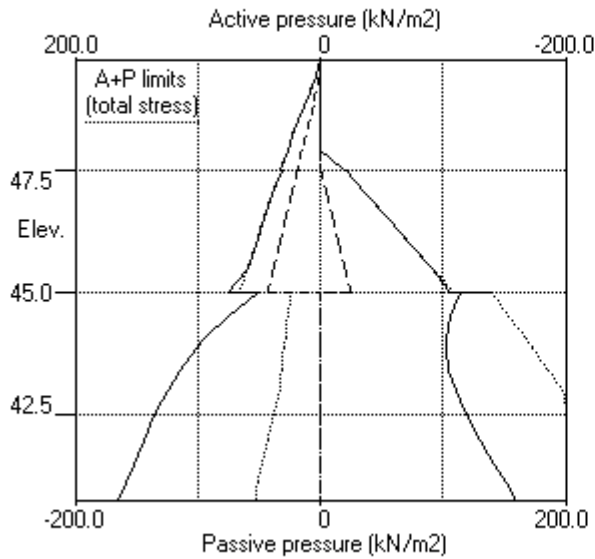

PILEDESIGNS LTD
 Program: WALLAP Version 6.06 Revision A51.B69.R54
 Licensed from GEOSOLVE
 Data filename/Run ID: Hampstead_Wall_2_450mm_rev_01_ULS2
 Hampstead - 24-26 Redington Gardens
 Wall 2, Secant-ULS2, 450 dia @ 650 - run 01

Sheet No.
 Job No. 21495
 Made by : DBS
 Date: 1-10-2018
 Checked :

Units: kN,m

Stage No. 6 Excavate to elevation 43.41 on RIGHT side

STABILITY ANALYSIS of Fully Embedded Wall according to Strength Factor method
 Factor of safety on soil strength

			Overall						
			FoS for toe	Toe elev. for					
			elev. = 40.75	FoS = 1.000					

Stage No.	--- G.L. Act.	--- Pass.	Strut Elev.	Factor of Safety	Moment of equil. at elev.	Toe elev.	Wall Penetr-ation	Direction of failure	
6	49.75	43.41	48.20	1.377	n/a	42.39	1.02	L to R	

BENDING MOMENT and DISPLACEMENT ANALYSIS of Fully Embedded Wall

Analysis options

Length of wall perpendicular to section = 50.00m
 Subgrade reaction model - Boussinesq Influence coefficients
 Soil deformations are elastic until the active or passive limit is reached
 Open Tension Crack analysis - No

Rigid boundaries: Left side 50.00 from wall
 Right side 50.00 from wall

Limit State: ULS DA1 Combination 2

Node no.	Y coord	Nett pressure kN/m2	Wall disp. m	Wall rotation rad.	Shear force kN/m	Bending moment kN.m/m	Strut forces kN/m	EI of wall kN.m2/m
1	49.75	0.00	0.014	-1.08E-03	0.0	-0.0		60696
2	49.40	20.81	0.014	-1.08E-03	3.6	0.5		60696
3	49.10	38.61	0.015	-1.09E-03	12.6	2.8		60696
4	48.80	37.63	0.015	-1.12E-03	24.0	8.0		60696
5	48.50	29.71	0.015	-1.18E-03	34.1	16.9		60696
6	48.20	22.58	0.016	-1.29E-03	41.9	28.5	142.2	60696
		22.58	0.016	-1.29E-03	-100.3	28.5		
7	47.90	26.87	0.016	-1.36E-03	-92.9	-0.5		60696
8	47.50	32.43	0.017	-1.24E-03	-81.0	-35.3		60696
		31.94	0.017	-1.24E-03	-81.0	-35.3		
9	47.00	38.85	0.017	-8.08E-04	-63.3	-71.6		60696
10	46.50	45.64	0.017	-1.08E-04	-42.2	-98.2		60696
11	46.00	52.34	0.017	7.62E-04	-17.7	-113.4		60696
12	45.50	58.98	0.017	1.70E-03	10.1	-115.5		60696
13	45.00	65.59	0.016	2.59E-03	41.3	-100.9		60696
		23.75	0.016	2.59E-03	41.3	-100.9		
14	44.53	26.12	0.014	3.30E-03	53.1	-79.8		60696
15	44.05	28.50	0.012	3.82E-03	66.1	-52.5		60696
16	43.85	29.50	0.012	3.97E-03	71.9	-38.8		60696
17	43.41	31.70	0.010	4.13E-03	85.4	-4.6		60696
		-67.23	0.010	4.13E-03	85.4	-4.6		
18	43.00	-76.88	0.008	4.06E-03	55.8	24.3		60696
19	42.50	-83.46	0.006	3.77E-03	15.7	46.1		60696
20	42.00	-61.29	0.004	3.40E-03	-20.4	43.3		60696
21	41.50	-22.85	0.003	3.10E-03	-41.5	29.3		60696
22	41.13	35.60	0.002	2.97E-03	-39.1	12.2		60696
23	40.75	172.87	0.001	2.93E-03	0.0	-0.0		---

At elev. 48.20 Strut force = 142.2 kN/strut = 142.2 kN/m run

(continued)

Stage No.6 Excavate to elevation 43.41 on RIGHT side

Node no.	Y coord	LEFT side					Total earth pressure kN/m2	Coeff. of subgrade reaction kN/m3
		Water press. kN/m2	Vertic -al kN/m2	Effective Active limit kN/m2	Effective Passive limit kN/m2	Earth pressure kN/m2		
1	49.75	0.00	0.00	0.00	0.00	0.00	0.00	6806
2	49.40	0.00	7.81	3.21	20.81	20.81	20.81p	6806
3	49.10	2.94	13.39	5.49	35.66	35.66	38.61p	6806
4	48.80	5.89	18.42	7.56	49.07	31.75	37.63	6806
5	48.50	8.83	22.67	9.30	60.38	20.88	29.71	6806
6	48.20	11.77	26.35	10.81	70.18	10.81	22.58a	2311
7	47.90	14.71	29.64	12.16	78.95	12.16	26.87a	2311
8	47.50	18.64	33.63	13.79	89.58	13.79	32.43a	2311
		18.64	33.63	13.31	93.76	13.31	31.94a	6637
9	47.00	23.54	38.69	15.31	107.87	15.31	38.85a	6637
10	46.50	28.45	43.44	17.19	121.11	17.19	45.64a	6637
11	46.00	33.35	47.98	18.98	133.77	18.98	52.34a	6637
12	45.50	38.26	52.38	20.72	146.03	20.72	58.98a	6637
13	45.00	43.16	56.68	22.43	158.02	22.43	65.59a	6637
		Total>	99.85	23.75m	185.21	23.75	23.75a	13420
14	44.53	Total>	109.01	26.12m	198.43	26.12	26.12a	14057
15	44.05	Total>	118.13	28.50m	211.61	28.50	28.50a	14695
16	43.85	Total>	121.96	29.50m	217.15	29.50	29.50a	14963
17	43.41	Total>	130.39	31.70m	229.33	31.70	31.70a	15554
18	43.00	Total>	138.23	33.75m	240.67	33.75	33.75a	16104
19	42.50	Total>	147.79	37.23	254.51	41.43	41.43	16775
20	42.00	Total>	157.36	42.37	268.34	77.87	77.87	17446
21	41.50	Total>	166.94	47.53	282.19	113.39	113.39	18117
22	41.13	Total>	174.13	51.40	292.58	139.90	139.90	18620
23	40.75	Total>	178.26	52.21	299.91	195.30	195.30	296978

Node no.	Y coord	RIGHT side					Total earth pressure kN/m2	Coeff. of subgrade reaction kN/m3
		Water press. kN/m2	Vertic -al kN/m2	Effective Active limit kN/m2	Effective Passive limit kN/m2	Earth pressure kN/m2		
1	49.75	0.00	0.00	0.00	0.00	0.00	0.00	0.0
2	49.40	0.00	0.00	0.00	0.00	0.00	0.00	0.0
3	49.10	0.00	0.00	0.00	0.00	0.00	0.00	0.0
4	48.80	0.00	0.00	0.00	0.00	0.00	0.00	0.0
5	48.50	0.00	0.00	0.00	0.00	0.00	0.00	0.0
6	48.20	0.00	0.00	0.00	0.00	0.00	0.00	0.0
7	47.90	0.00	0.00	0.00	0.00	0.00	0.00	0.0
8	47.50	0.00	0.00	0.00	0.00	0.00	0.00	0.0
9	47.00	0.00	0.00	0.00	0.00	0.00	0.00	0.0
10	46.50	0.00	0.00	0.00	0.00	0.00	0.00	0.0
11	46.00	0.00	0.00	0.00	0.00	0.00	0.00	0.0
12	45.50	0.00	0.00	0.00	0.00	0.00	0.00	0.0
13	45.00	0.00	0.00	0.00	0.00	0.00	0.00	0.0
14	44.53	0.00	0.00	0.00	0.00	0.00	0.00	0.0
15	44.05	0.00	0.00	0.00	0.00	0.00	0.00	0.0
16	43.85	0.00	0.00	0.00	0.00	0.00	0.00	0.0
17	43.41	0.00	0.00	0.00	0.00	0.00	0.00	0.0
		Total>	0.00	0.00	98.93	98.93	98.93p	31395
18	43.00	Total>	8.20	2.05m	110.63	110.63	110.63p	32506
19	42.50	Total>	18.20	4.55m	124.90	124.90	124.90p	33860
20	42.00	Total>	28.20	7.05m	139.17	139.17	139.17p	35215
21	41.50	Total>	38.20	9.55m	153.44	136.25	136.25	36569
22	41.13	Total>	45.70	11.42m	164.14	104.30	104.30	37585

Run ID. Hampstead_Wall_2_450mm_rev_01_ULS2
 Hampstead - 24-26 Redington Gardens
 Wall 2, Secant-ULS2, 450 dia @ 650 - run 01

| Sheet No.
 | Date: 1-10-2018
 | Checked :

(continued)

Stage No.6 Excavate to elevation 43.41 on RIGHT side

Node no.	Y coord	----- Effective stresses -----					Total earth pressure	Coeff. of subgrade reaction
		Water press. kN/m2	Vertic -al kN/m2	Active limit kN/m2	Passive limit kN/m2	Earth pressure kN/m2		
23	40.75	Total>	53.21	13.30m	174.85	22.43	22.43	523231

Note: 33.75a Soil pressure at active limit
 139.17p Soil pressure at passive limit

Units: kN,m

Stage No.6 Excav. to elev. 43.41 on RIGHT side

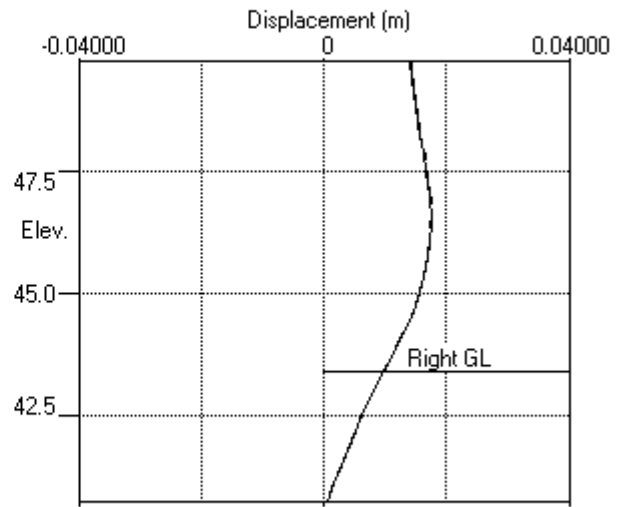
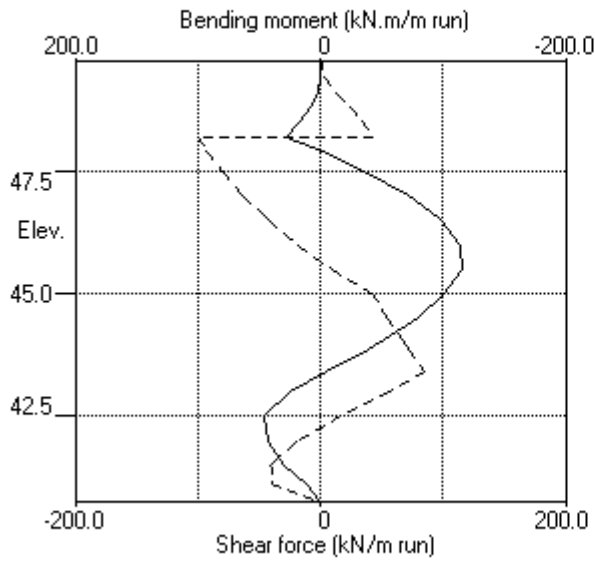

Stage No.6 Excav. to elev. 43.41 on RIGHT side

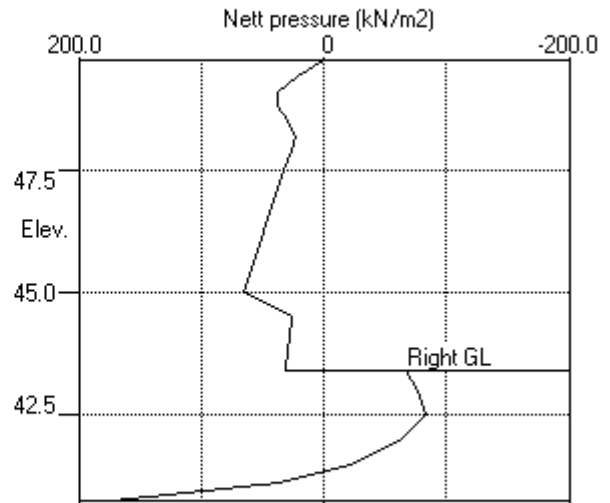
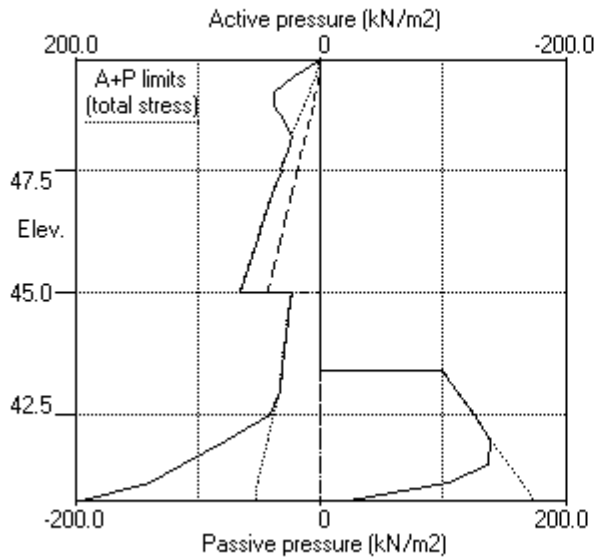

PILEDESIGNS LTD
 Program: WALLAP Version 6.06 Revision A51.B69.R54
 Licensed from GEOSOLVE
 Data filename/Run ID: Hampstead_Wall_2_450mm_rev_01_ULS2
 Hampstead - 24-26 Redington Gardens
 Wall 2, Secant-ULS2, 450 dia @ 650 - run 01

Sheet No.
 Job No. 21495
 Made by : DBS
 Date: 1-10-2018
 Checked :

Units: kN,m

Stage No. 7 Fill to elevation 43.85 on RIGHT side with soil type 1

STABILITY ANALYSIS of Fully Embedded Wall according to Strength Factor method
 Factor of safety on soil strength

			Overall					
			FoS for toe		Toe elev. for			
			elev. = 40.75		FoS = 1.000			

Stage No.	--- G.L. Act.	--- Pass.	Strut Elev.	Factor of Safety	Moment of equil. at elev.	Toe elev.	Wall Penetr-ation	Direction of failure
7	49.75	43.85	48.20	1.443	n/a	42.50	1.35	L to R

BENDING MOMENT and DISPLACEMENT ANALYSIS of Fully Embedded Wall

Analysis options

Length of wall perpendicular to section = 50.00m

Subgrade reaction model - Boussinesq Influence coefficients

Soil deformations are elastic until the active or passive limit is reached

Open Tension Crack analysis - No

Rigid boundaries: Left side 50.00 from wall

Right side 50.00 from wall

Limit State: ULS DA1 Combination 2

Node no.	Y coord	Nett pressure kN/m2	Wall disp. m	Wall rotation rad.	Shear force kN/m	Bending moment kN.m/m	Strut forces kN/m	EI of wall kN.m2/m
1	49.75	0.00	0.014	-1.08E-03	0.0	-0.0		60696
2	49.40	20.77	0.014	-1.08E-03	3.6	0.5		60696
3	49.10	38.57	0.015	-1.09E-03	12.5	2.8		60696
4	48.80	37.61	0.015	-1.11E-03	24.0	7.9		60696
5	48.50	29.70	0.015	-1.17E-03	34.1	16.9		60696
6	48.20	22.58	0.016	-1.29E-03	41.9	28.5	142.6	60696
		22.58	0.016	-1.29E-03	-100.7	28.5		
7	47.90	26.88	0.016	-1.36E-03	-93.2	-0.6		60696
8	47.50	32.44	0.017	-1.24E-03	-81.4	-35.6		60696
		31.97	0.017	-1.24E-03	-81.4	-35.6		
9	47.00	38.92	0.017	-7.97E-04	-63.7	-72.1		60696
10	46.50	45.75	0.017	-9.36E-05	-42.5	-98.9		60696
11	46.00	52.53	0.017	7.83E-04	-17.9	-114.2		60696
12	45.50	59.27	0.017	1.73E-03	10.0	-116.4		60696
13	45.00	66.00	0.015	2.63E-03	41.3	-101.9		60696
		24.57	0.015	2.63E-03	41.3	-101.9		
14	44.53	27.29	0.014	3.34E-03	53.7	-80.7		60696
15	44.05	30.10	0.012	3.86E-03	67.3	-52.9		60696
16	43.85	31.29	0.012	4.02E-03	73.4	-38.9		60696
17	43.41	30.71	0.010	4.17E-03	87.1	-4.0		60696
		-70.32	0.010	4.17E-03	87.1	-4.0		
18	43.00	-79.11	0.008	4.10E-03	56.4	25.3		60696
19	42.50	-84.73	0.006	3.80E-03	15.5	47.1		60696
20	42.00	-61.70	0.004	3.43E-03	-21.1	44.1		60696
21	41.50	-22.48	0.003	3.12E-03	-42.2	29.7		60696
22	41.13	36.53	0.001	2.99E-03	-39.5	12.3		60696
23	40.75	174.37	0.000	2.95E-03	0.0	-0.0		---

At elev. 48.20 Strut force = 142.6 kN/strut = 142.6 kN/m run

(continued)

Stage No.7 Fill to elevation 43.85 on RIGHT side with soil type 1

Node no.	Y coord	LEFT side					Total earth pressure	Coeff. of subgrade reaction
		Water press. kN/m2	Vertic -al kN/m2	Effective Active limit kN/m2	Effective Passive limit kN/m2	Earth pressure kN/m2		
1	49.75	0.00	0.00	0.00	0.00	0.00	0.00	6456
2	49.40	0.00	7.81	3.21	20.81	20.77	20.77	6456
3	49.10	2.94	13.39	5.49	35.66	35.63	38.57	6456
4	48.80	5.89	18.42	7.56	49.07	31.73	37.61	6456
5	48.50	8.83	22.67	9.30	60.38	20.87	29.70	6456
6	48.20	11.77	26.35	10.81	70.18	10.81	22.58a	6456
7	47.90	14.71	29.64	12.16	78.95	12.16	26.88a	2795
8	47.50	18.64	33.63	13.79	89.58	13.80	32.44	2795
		18.64	33.63	13.31	93.76	13.33	31.97	8048
9	47.00	23.54	38.69	15.31	107.87	15.37	38.92	8048
10	46.50	28.45	43.44	17.19	121.11	17.30	45.75	8048
11	46.00	33.35	47.98	18.98	133.77	19.17	52.53	8048
12	45.50	38.26	52.38	20.72	146.03	21.01	59.27	8048
13	45.00	43.16	56.68	22.43	158.02	22.84	66.00	8048
		Total>	99.85	23.75m	185.21	24.57	24.57	15884
14	44.53	Total>	109.01	26.12m	198.43	27.29	27.29	16638
15	44.05	Total>	118.13	28.50m	211.61	30.10	30.10	17393
16	43.85	Total>	121.96	29.50m	217.15	31.29	31.29	17710
17	43.41	Total>	130.39	31.70m	229.33	33.96	33.96	18409
18	43.00	Total>	138.23	33.75m	240.67	36.43	36.43	19060
19	42.50	Total>	147.79	37.23	254.51	44.60	44.60	19855
20	42.00	Total>	157.36	42.37	268.34	81.47	81.47	20649
21	41.50	Total>	166.94	47.53	282.19	117.38	117.38	21443
22	41.13	Total>	174.13	51.40	292.58	144.17	144.17	22039
23	40.75	Total>	178.26	52.21	299.91	199.85	199.85	22634

Node no.	Y coord	RIGHT side					Total earth pressure	Coeff. of subgrade reaction
		Water press. kN/m2	Vertic -al kN/m2	Effective Active limit kN/m2	Effective Passive limit kN/m2	Earth pressure kN/m2		
1	49.75	0.00	0.00	0.00	0.00	0.00	0.00	0.0
2	49.40	0.00	0.00	0.00	0.00	0.00	0.00	0.0
3	49.10	0.00	0.00	0.00	0.00	0.00	0.00	0.0
4	48.80	0.00	0.00	0.00	0.00	0.00	0.00	0.0
5	48.50	0.00	0.00	0.00	0.00	0.00	0.00	0.0
6	48.20	0.00	0.00	0.00	0.00	0.00	0.00	0.0
7	47.90	0.00	0.00	0.00	0.00	0.00	0.00	0.0
8	47.50	0.00	0.00	0.00	0.00	0.00	0.00	0.0
9	47.00	0.00	0.00	0.00	0.00	0.00	0.00	0.0
10	46.50	0.00	0.00	0.00	0.00	0.00	0.00	0.0
11	46.00	0.00	0.00	0.00	0.00	0.00	0.00	0.0
12	45.50	0.00	0.00	0.00	0.00	0.00	0.00	0.0
13	45.00	0.00	0.00	0.00	0.00	0.00	0.00	0.0
14	44.53	0.00	0.00	0.00	0.00	0.00	0.00	0.0
15	44.05	0.00	0.00	0.00	0.00	0.00	0.00	0.0
16	43.85	0.00	0.00	0.00	0.00	0.00	0.00	0.0
		0.00	0.00	0.00	0.00	0.00	0.00	2804
17	43.41	0.00	7.92	3.25	21.10	3.25	3.25a	2804
		Total>	7.92	2.20m	106.85	104.27	104.27	18462
18	43.00	Total>	16.12	4.25m	118.55	115.55	115.55	19115
19	42.50	Total>	26.12	6.75m	132.82	129.33	129.33	19912
20	42.00	Total>	36.12	9.25m	147.09	143.17	143.17	20708
21	41.50	Total>	46.12	11.75m	161.36	139.86	139.86	21504

(continued)

Stage No.7 Fill to elevation 43.85 on RIGHT side with soil type 1

Node no.	Y coord	----- RIGHT side -----					Total earth pressure	Coeff. of subgrade reaction
		Water press. kN/m2	Vertical -al kN/m2	Effective stresses Active limit kN/m2	Passive limit kN/m2	Earth pressure kN/m2		
22	41.13	Total>	53.63	13.62m	172.07	107.63	107.63	22102
23	40.75	Total>	61.13	15.50m	182.77	25.48	25.48	22699

Note: 3.25a Soil pressure at active limit
 123.45p Soil pressure at passive limit

Units: kN,m

Stage No.7 Fill to elev. 43.85 on RIGHT side

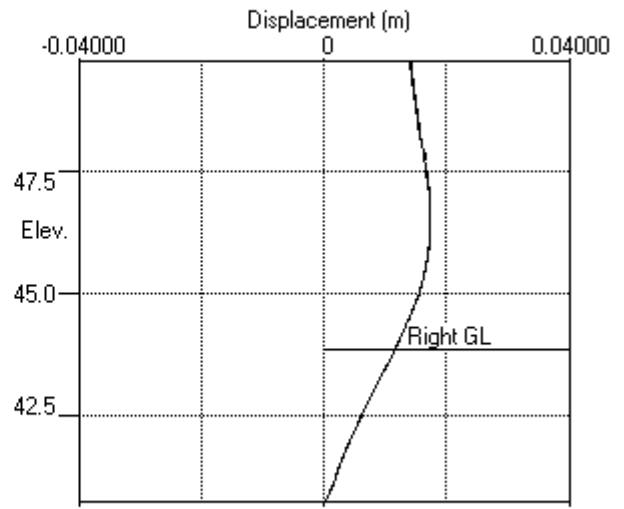
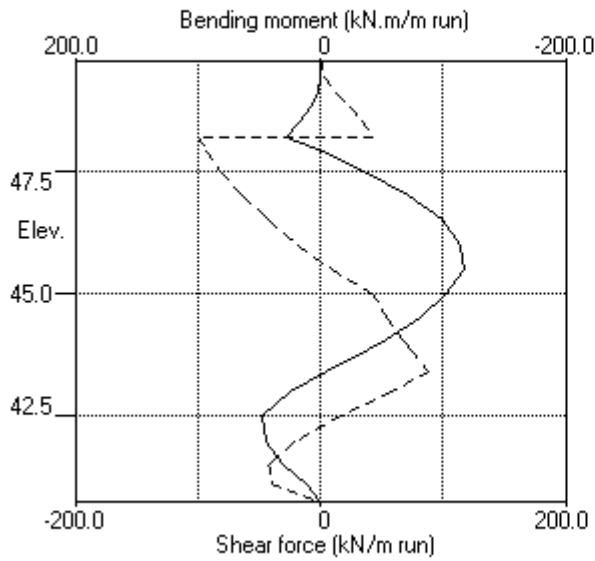

Stage No.7 Fill to elev. 43.85 on RIGHT side

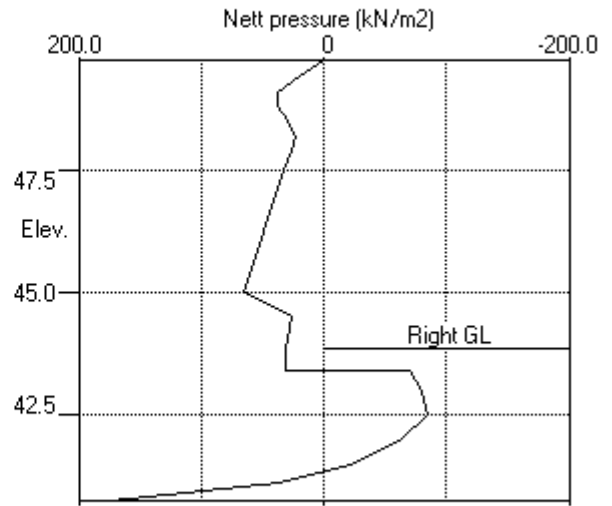
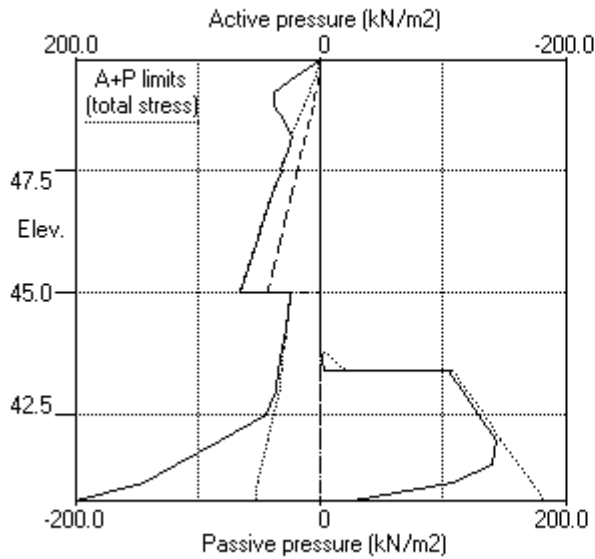

PILEDESIGNS LTD
 Program: WALLAP Version 6.06 Revision A51.B69.R54
 Licensed from GEOSOLVE
 Data filename/Run ID: Hampstead_Wall_2_450mm_rev_01_ULS2
 Hampstead - 24-26 Redington Gardens
 Wall 2, Secant-ULS2, 450 dia @ 650 - run 01

Sheet No.
 Job No. 21495
 Made by : DBS
 Date: 1-10-2018
 Checked :

Units: kN,m

Stage No. 9 Change EI of wall to 43355 kN.m²/m run
 Yield moment not defined
 Allow wall to relax with new modulus value

STABILITY ANALYSIS of Fully Embedded Wall according to Strength Factor method
 Factor of safety on soil strength

		Overall					
		FoS for toe		Toe elev. for			
		elev. = 40.75		FoS = 1.000			

Stage No.	--- G.L. --- Act. Pass.	Strut Elev.	Factor of Safety	Moment of equilib. at elev.	Toe elev.	Wall Penetr -ation	Direction of failure
9	49.75 43.85		More than one strut.	No FoS calc.			

BENDING MOMENT and DISPLACEMENT ANALYSIS of Fully Embedded Wall

Analysis options

Length of wall perpendicular to section = 50.00m

Subgrade reaction model - Boussinesq Influence coefficients

Soil deformations are elastic until the active or passive limit is reached

Open Tension Crack analysis - No

Rigid boundaries: Left side 50.00 from wall

Right side 50.00 from wall

Limit State: ULS DA1 Combination 2

Node no.	Y coord	Nett pressure kN/m ²	Wall disp. m	Wall rotation rad.	Shear force kN/m	Bending moment kN.m/m	Strut forces kN/m	EI of wall kN.m ² /m
1	49.75	0.00	0.013	-1.41E-03	0.0	-0.0		43355
2	49.40	20.81	0.014	-1.41E-03	3.6	0.5		43355
3	49.10	38.61	0.014	-1.42E-03	12.6	2.8		43355
4	48.80	39.12	0.015	-1.46E-03	24.2	7.9		43355
5	48.50	30.51	0.015	-1.55E-03	34.7	17.0		43355
6	48.20	22.62	0.016	-1.71E-03	42.6	28.8	137.0	43355
		22.62	0.016	-1.71E-03	-94.4	28.8		
7	47.90	26.87	0.016	-1.81E-03	-87.0	1.1		43355
8	47.50	32.43	0.017	-1.68E-03	-75.1	-31.9		43355
		31.94	0.017	-1.68E-03	-75.1	-31.9		
9	47.00	38.85	0.018	-1.13E-03	-57.4	-66.0		43355
10	46.50	45.64	0.018	-2.57E-04	-36.3	-90.3		43355
11	46.00	52.34	0.018	8.26E-04	-11.8	-103.3		43355
12	45.50	58.98	0.017	1.97E-03	16.0	-103.1		43355
13	45.00	65.59	0.016	3.02E-03	47.2	-86.3		43355
		23.75	0.016	3.02E-03	47.2	-86.3		
14	44.53	26.12	0.014	3.78E-03	59.0	-63.0		43355
15	44.05	29.53	0.012	4.25E-03	72.2	-33.4	25.1	43355
		29.53	0.012	4.25E-03	47.1	-33.4		
16	43.85	32.27	0.012	4.36E-03	53.3	-22.5		43355
17	43.41	34.70	0.010	4.41E-03	68.0	5.6		43355
		-62.34	0.010	4.41E-03	68.0	5.6		
18	43.00	-67.28	0.008	4.22E-03	41.5	29.4		43355
19	42.50	-71.13	0.006	3.78E-03	6.8	46.5		43355
20	42.00	-49.89	0.004	3.28E-03	-23.4	41.4		43355
21	41.50	-15.52	0.002	2.89E-03	-39.8	27.3		43355
22	41.13	38.74	0.001	2.73E-03	-35.4	10.9		43355
23	40.75	150.11	0.000	2.68E-03	0.0	-0.0		---
At elev. 48.20		Strut force =		137.0 kN/strut =	137.0 kN/m run			
At elev. 44.05		Strut force =		25.1 kN/strut =	25.1 kN/m run			

(continued)

Stage No.9 Change EI of wall to 43355 kN.m2/m run
Yield moment not defined
Allow wall to relax with new modulus value

Node no.	Y coord	LEFT side					Total earth pressure	Coeff. of subgrade reaction
		Water press.	Vertic -al	Effective Active limit	Effective Passive limit	Earth pressure		
		kN/m2	kN/m2	kN/m2	kN/m2	kN/m2	kN/m2	kN/m3
1	49.75	0.00	0.00	0.00	0.00	0.00	0.00	6473
2	49.40	0.00	7.81	3.21	20.81	20.81	20.81p	6473
3	49.10	2.94	13.39	5.49	35.66	35.66	38.61p	6473
4	48.80	5.89	18.42	7.56	49.07	33.24	39.12	6473
5	48.50	8.83	22.67	9.30	60.38	21.68	30.51	6473
6	48.20	11.77	26.35	10.81	70.18	10.85	22.62	6473
7	47.90	14.71	29.64	12.16	78.95	12.16	26.87a	3048
8	47.50	18.64	33.63	13.79	89.58	13.79	32.43a	3048
		18.64	33.63	13.31	93.76	13.31	31.94a	8784
9	47.00	23.54	38.69	15.31	107.87	15.31	38.85a	8784
10	46.50	28.45	43.44	17.19	121.11	17.19	45.64a	8784
11	46.00	33.35	47.98	18.98	133.77	18.98	52.34a	8784
12	45.50	38.26	52.38	20.72	146.03	20.72	58.98a	8784
13	45.00	43.16	56.68	22.43	158.02	22.43	65.59a	8784
		Total>	99.85	23.75m	185.21	23.75	23.75a	17183
14	44.53	Total>	109.01	26.12m	198.43	26.12	26.12a	17999
15	44.05	Total>	118.13	28.50m	211.61	29.53	29.53	18815
16	43.85	Total>	121.96	29.50m	217.15	32.27	32.27	22608
17	43.41	Total>	130.39	31.70m	229.33	37.95	37.95	23500
18	43.00	Total>	138.23	33.75m	240.67	42.35	42.35	24332
19	42.50	Total>	147.79	37.23	254.51	51.40	51.40	25345
20	42.00	Total>	157.36	42.37	268.34	87.37	87.37	26359
21	41.50	Total>	166.94	47.53	282.19	120.86	120.86	27373
22	41.13	Total>	174.13	51.40	292.58	145.27	145.27	33062
23	40.75	Total>	178.26	52.21	299.91	187.72	187.72	180686

Node no.	Y coord	RIGHT side					Total earth pressure	Coeff. of subgrade reaction
		Water press.	Vertic -al	Effective Active limit	Effective Passive limit	Earth pressure		
		kN/m2	kN/m2	kN/m2	kN/m2	kN/m2	kN/m2	kN/m3
1	49.75	0.00	0.00	0.00	0.00	0.00	0.00	0.0
2	49.40	0.00	0.00	0.00	0.00	0.00	0.00	0.0
3	49.10	0.00	0.00	0.00	0.00	0.00	0.00	0.0
4	48.80	0.00	0.00	0.00	0.00	0.00	0.00	0.0
5	48.50	0.00	0.00	0.00	0.00	0.00	0.00	0.0
6	48.20	0.00	0.00	0.00	0.00	0.00	0.00	0.0
7	47.90	0.00	0.00	0.00	0.00	0.00	0.00	0.0
8	47.50	0.00	0.00	0.00	0.00	0.00	0.00	0.0
9	47.00	0.00	0.00	0.00	0.00	0.00	0.00	0.0
10	46.50	0.00	0.00	0.00	0.00	0.00	0.00	0.0
11	46.00	0.00	0.00	0.00	0.00	0.00	0.00	0.0
12	45.50	0.00	0.00	0.00	0.00	0.00	0.00	0.0
13	45.00	0.00	0.00	0.00	0.00	0.00	0.00	0.0
14	44.53	0.00	0.00	0.00	0.00	0.00	0.00	0.0
15	44.05	0.00	0.00	0.00	0.00	0.00	0.00	0.0
16	43.85	0.00	0.00	0.00	0.00	0.00	0.00	0.0
		0.00	0.00	0.00	0.00	0.00	0.00	3646
17	43.41	0.00	7.92	3.25	21.10	3.25	3.25a	3646
		Total>	7.92	2.20m	106.85	100.28	100.28	23500
18	43.00	Total>	16.12	4.25m	118.55	109.63	109.63	24332
19	42.50	Total>	26.12	6.75m	132.82	122.53	122.53	25345

(continued)

Stage No.9 Change EI of wall to 43355 kN.m2/m run
 Yield moment not defined
 Allow wall to relax with new modulus value

Node no.	Y coord	----- RIGHT side -----						Total earth pressure	Coeff. of subgrade reaction
		Water press.	Vertic -al	Effective Active limit	Effective Passive limit	Earth pressure	Earth pressure		
		kN/m2	kN/m2	kN/m2	kN/m2	kN/m2	kN/m2	kN/m3	
20	42.00	Total>	36.12	9.25m	147.09	137.27	137.27	26359	
21	41.50	Total>	46.12	11.75m	161.36	136.38	136.38	27373	
22	41.13	Total>	53.63	13.62m	172.07	106.53	106.53	33062	
23	40.75	Total>	61.13	15.50m	182.77	37.61	37.61	180686	

Note: 3.25a Soil pressure at active limit
 38.61p Soil pressure at passive limit

Units: kN,m

Stage No.9 Change EI of wall to 43355kN.m2/m run

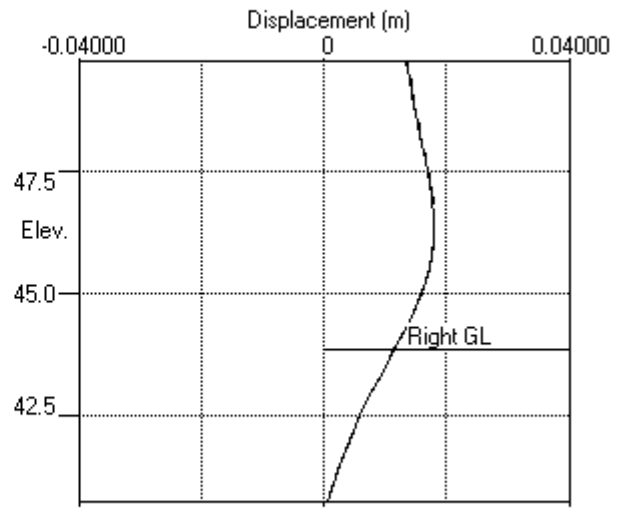
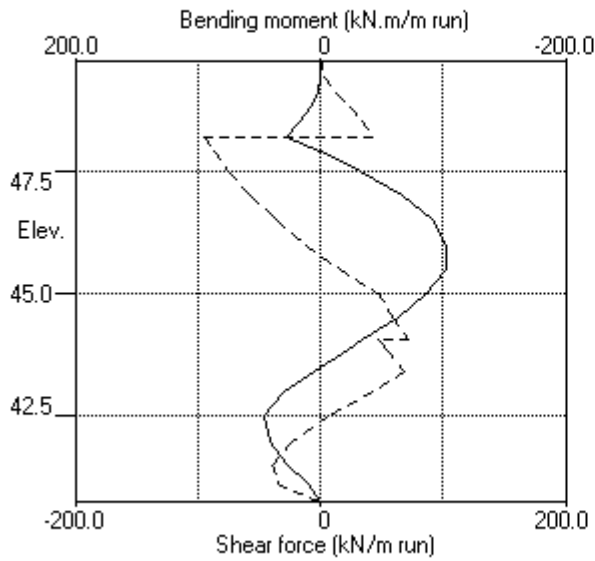

Stage No.9 Change EI of wall to 43355kN.m2/m run

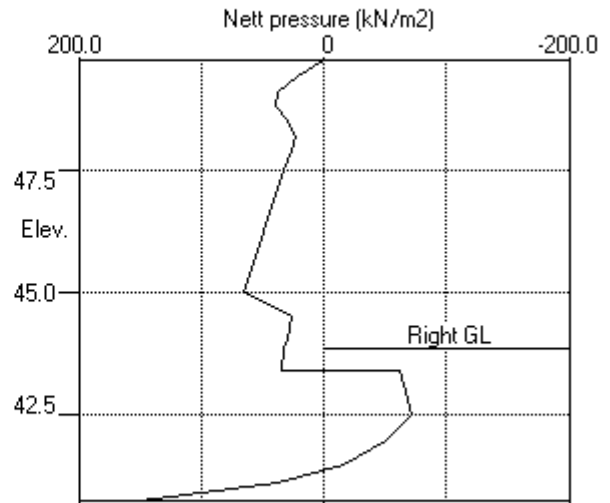
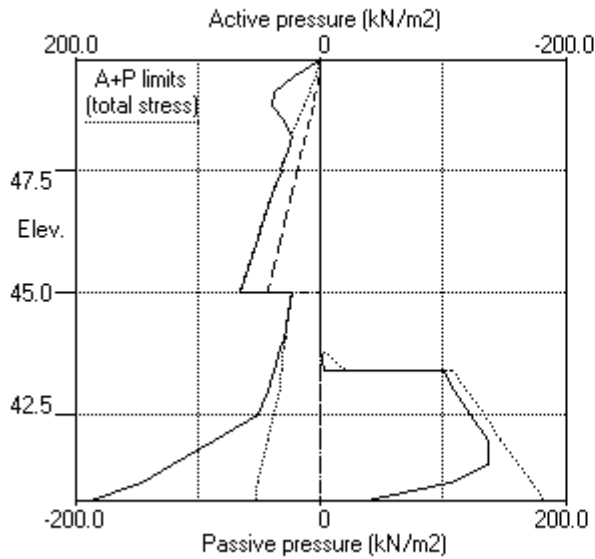

Units: kN,m

Stage No. 10 Change properties of soil type 3 to soil type 4
 Ko pressures will not be reset

STABILITY ANALYSIS of Fully Embedded Wall according to Strength Factor method
 Factor of safety on soil strength

			Overall				
			FoS for toe	Toe elev. for			
			elev. = 40.75	FoS = 1.000			

Stage	--- G.L. ---	Strut	Factor	Moment	Toe	Wall	Direction
No.	Act. Pass.	Elev.	of	equilib.	elev.	Penetr	of
			Safety	at elev.		-ation	failure
10	49.75 43.85		More than one strut. No FoS calc.				

** FLOW Warning - Weak strata at or below toe of wall:
 Active limit > Passive limit
 125.87kN/m2 (left) > 121.57kN/m2 (right) at elev. 40.75
 [41.01+84.86(u)] [99.50+22.07(u)]
 The above pressures include water pressure.

Failure and flow of soil BELOW the toe of the wall may occur if
 the wall is not toed in to a firm stratum. This may occur even when
 acceptable factors of safety and displacements have been calculated.

BENDING MOMENT and DISPLACEMENT ANALYSIS of Fully Embedded Wall

Analysis options

Length of wall perpendicular to section = 50.00m
 Subgrade reaction model - Boussinesq Influence coefficients
 Soil deformations are elastic until the active or passive limit is reached
 Open Tension Crack analysis - No

Rigid boundaries: Left side 50.00 from wall
 Right side 50.00 from wall

Limit State: ULS DA1 Combination 2

Node no.	Y coord	Nett pressure kN/m2	Wall disp. m	Wall rotation rad.	Shear force kN/m	Bending moment kN.m/m	Strut forces kN/m	EI of wall kN.m2/m
1	49.75	0.00	0.015	-1.85E-04	0.0	-0.0		43355
2	49.40	10.84	0.015	-1.87E-04	1.9	0.5		43355
3	49.10	31.13	0.015	-1.95E-04	8.2	1.8		43355
4	48.80	34.16	0.015	-2.20E-04	18.0	5.3		43355
5	48.50	28.10	0.016	-2.81E-04	27.3	12.3		43355
6	48.20	22.71	0.016	-3.99E-04	35.0	21.8	111.2	43355
		22.71	0.016	-3.99E-04	-76.2	21.8		
7	47.90	28.17	0.016	-4.75E-04	-68.6	-0.4		43355
8	47.50	35.34	0.016	-3.60E-04	-55.9	-26.0		43355
		40.31	0.016	-3.60E-04	-55.9	-26.0		
9	47.00	52.72	0.016	5.77E-05	-32.6	-49.4		43355
10	46.50	64.14	0.016	6.62E-04	-3.4	-59.6		43355
11	46.00	73.91	0.015	1.28E-03	31.1	-53.8		43355
12	45.50	81.11	0.015	1.72E-03	69.8	-29.6		43355
13	45.00	84.54	0.014	1.75E-03	111.3	17.0		43355
		67.26	0.014	1.75E-03	111.3	17.0		
14	44.53	73.83	0.013	1.19E-03	144.8	75.8		43355
15	44.05	80.39	0.013	-1.13E-04	181.4	151.6	322.0	43355
		80.39	0.013	-1.13E-04	-140.7	151.6		
16	43.85	83.15	0.013	-7.77E-04	-124.3	126.0		43355
17	43.41	70.37	0.013	-1.86E-03	-90.5	80.8		43355
		69.03	0.013	-1.86E-03	-90.5	80.8		

(continued)

Stage No.10 Change properties of soil type 3 to soil type 4
Ko pressures will not be reset

Node no.	Y coord	----- RIGHT side -----					Total earth pressure kN/m2	Coeff. of subgrade reaction kN/m3
		Water press. kN/m2	Vertical kN/m2	Effective Active limit kN/m2	Effective Passive limit kN/m2	Earth pressure kN/m2		
11	46.00	0.00	0.00	0.00	0.00	0.00	0.00	0.0
12	45.50	0.00	0.00	0.00	0.00	0.00	0.00	0.0
13	45.00	0.00	0.00	0.00	0.00	0.00	0.00	0.0
14	44.53	0.00	0.00	0.00	0.00	0.00	0.00	0.0
15	44.05	0.00	0.00	0.00	0.00	0.00	0.00	0.0
16	43.85	0.00	0.00	0.00	0.00	0.00	0.00	0.0
		0.00	0.00	0.00	0.00	0.00	0.00	4053
17	43.41	0.00	7.92	3.25	21.10	18.84	18.84	4053
		0.00	7.92	3.37	20.18	20.18	20.18p	13933
18	43.00	0.00	16.12	6.85	41.06	41.06	41.06p	14426
19	42.50	4.90	21.22	9.02	54.05	54.05	58.95p	15027
20	42.00	9.81	26.31	11.19	67.03	67.03	76.84p	15628
21	41.50	14.71	31.41	13.35	80.01	80.01	94.73p	16229
22	41.13	18.39	35.23	14.98	89.76	89.76	108.15p	16680
23	40.75	22.07	39.06	16.60	99.50	99.50	121.57p	17131

Note: 125.87a Soil pressure at active limit
121.57p Soil pressure at passive limit

Units: kN,m

Stage No.10 Change soil type 3 to soil type 4

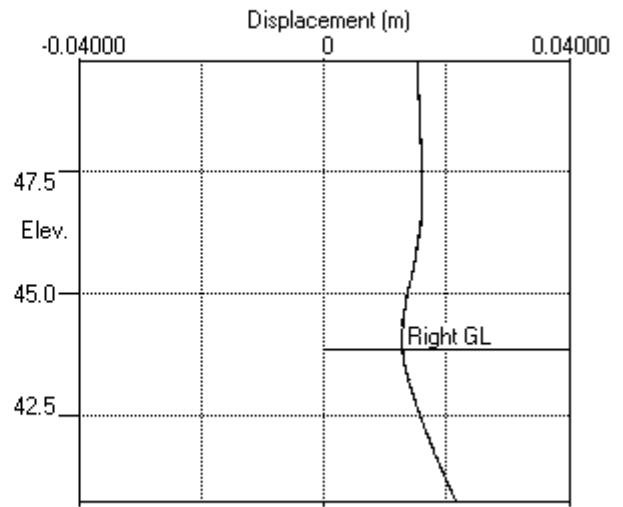
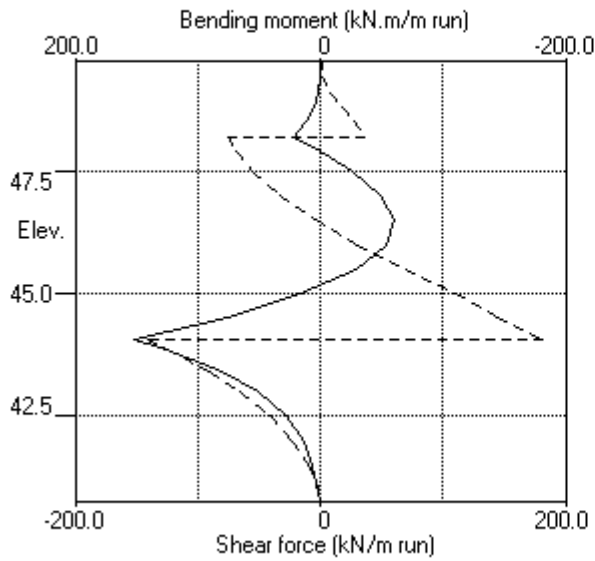

Stage No.10 Change soil type 3 to soil type 4

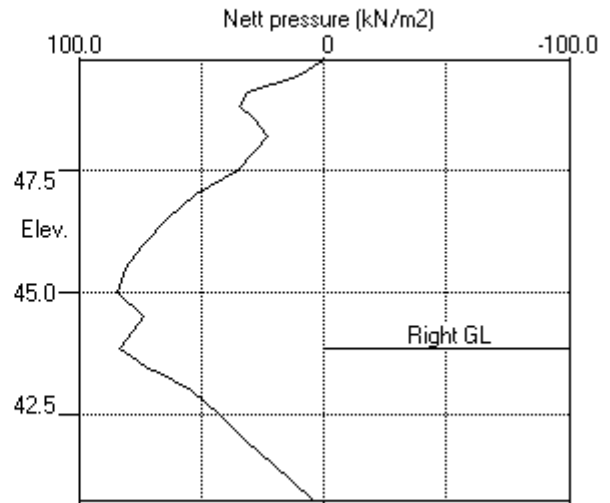
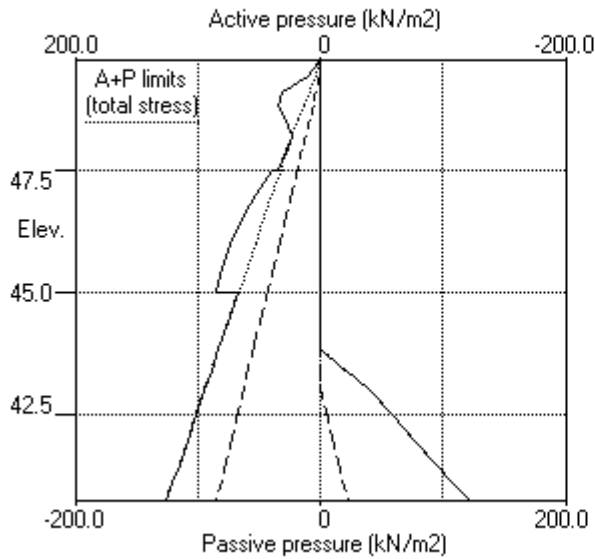

PILEDESIGNS LTD
 Program: WALLAP Version 6.06 Revision A51.B69.R54
 Licensed from GEOSOLVE
 Data filename/Run ID: Hampstead_Wall_2_450mm_rev_01_ULS2
 Hampstead - 24-26 Redington Gardens
 Wall 2, Secant-ULS2, 450 dia @ 650 - run 01

Sheet No.
 Job No. 21495
 Made by : DBS
 Date: 1-10-2018
 Checked :

Units: kN,m

Summary of results

LIMIT STATE PARAMETERS

Limit State: ULS DA1 Combination 2
 Water pressures : Worst Credible
 Partial factor on C' = 1.250
 Partial factor on Phi' = 1.250
 Partial factor on Cu = 1.400
 Partial factor on Soil Modulus = 1.000
 Partial factor on Permanent Unfavourable loads = 1.000
 Partial factor on Permanent Favourable loads = 1.000
 Partial factor on Variable Unfavourable loads = 1.300

STABILITY ANALYSIS of Fully Embedded Wall according to Strength Factor method

Factor of safety on soil strength

			Overall						
			FoS for toe		Toe elev. for				
			elev. = 40.75		FoS = 1.000				

Stage No.	--- G.L. Act.	--- Pass.	Strut Elev.	Factor of Safety	Moment at elev.	Toe elev.	Wall Penetr-ation	Direction of failure	
1	49.75	49.75	Cant.	Conditions not suitable for FoS calc.					
2	49.75	49.75	Cant.	Conditions not suitable for FoS calc.					
3	49.75	47.90	Cant.	1.642	41.78	43.15	4.75	L to R	
4	49.75	47.90		No analysis at this stage					
5	49.75	47.90	48.20	Conditions not suitable for FoS calc.					
6	49.75	43.41	48.20	1.377	n/a	42.39	1.02	L to R	
7	49.75	43.85	48.20	1.443	n/a	42.50	1.35	L to R	
8	49.75	43.85		No analysis at this stage					
9	49.75	43.85		More than one strut. No FoS calc.					
10	49.75	43.85		More than one strut. No FoS calc. **FLOW Warning					
11	49.75	43.85		No analysis at this stage					
12	49.75	43.85		More than one strut. No FoS calc.					

Legend: **FLOW Warning

Failure and flow of soil BELOW the toe of the wall may occur if the wall is not toed in to a firm stratum. It may occur even when acceptable factors of safety and displacements have been calculated. See individual stage results for details.

PILEDESIGNS LTD
 Program: WALLAP Version 6.06 Revision A51.B69.R54
 Licensed from GEOSOLVE
 Data filename/Run ID: Hampstead_Wall_2_450mm_rev_01_ULS2
 Hampstead - 24-26 Redington Gardens
 Wall 2, Secant-ULS2, 450 dia @ 650 - run 01

Sheet No.
 Job No. 21495
 Made by : DBS
 Date: 1-10-2018
 Checked :

Units: kN,m

Summary of results

BENDING MOMENT and DISPLACEMENT ANALYSIS of Fully Embedded Wall

Analysis options

Length of wall perpendicular to section = 50.00m
 Subgrade reaction model - Boussinesq Influence coefficients
 Soil deformations are elastic until the active or passive limit is reached
 Open Tension Crack analysis - No

Rigid boundaries: Left side 50.00 from wall
 Right side 50.00 from wall

Limit State: ULS DA1 Combination 2

Bending moment, shear force and displacement envelopes

Node no.	Y coord	Displacement		Bending moment		Shear force	
		maximum m	minimum m	maximum kN.m/m	minimum kN.m/m	maximum kN/m	minimum kN/m
1	49.75	0.023	0.000	0.0	-0.0	0.0	0.0
2	49.40	0.022	0.000	0.5	-0.0	3.6	-1.0
3	49.10	0.020	0.000	2.8	-0.5	12.6	-2.4
4	48.80	0.019	0.000	8.0	-1.3	24.2	-2.8
5	48.50	0.017	0.000	17.0	-2.1	34.7	-2.3
6	48.20	0.016	0.000	28.8	-2.6	42.6	-100.7
7	47.90	0.016	0.000	14.0	-2.7	23.8	-93.2
8	47.50	0.017	0.000	25.4	-35.6	31.9	-81.4
9	47.00	0.018	0.000	42.2	-72.1	35.1	-63.7
10	46.50	0.018	0.000	59.3	-98.9	32.9	-42.5
11	46.00	0.018	0.000	74.0	-114.2	31.1	-17.9
12	45.50	0.017	0.000	83.4	-116.4	69.8	0.0
13	45.00	0.016	0.000	87.2	-101.9	111.3	-3.8
14	44.53	0.014	0.000	78.3	-80.7	144.8	-26.0
15	44.05	0.013	0.000	151.6	-52.9	181.4	-140.7
16	43.85	0.013	0.000	126.0	-38.9	73.4	-124.3
17	43.41	0.013	0.000	83.0	-4.6	87.1	-90.5
18	43.00	0.014	0.000	58.5	0.0	56.4	-65.3
19	42.50	0.016	0.000	47.1	0.0	15.7	-42.0
20	42.00	0.017	0.000	44.1	0.0	0.0	-28.8
21	41.50	0.019	0.000	29.7	0.0	0.0	-42.2
22	41.13	0.020	0.000	12.3	0.0	0.0	-39.5
23	40.75	0.021	0.000	0.0	-0.0	0.0	-0.0

Maximum and minimum bending moment and shear force at each stage

Stage no.	Bending moment				Shear force			
	maximum kN.m/m	elev.	minimum kN.m/m	elev.	maximum kN/m	elev.	minimum kN/m	elev.
1	2.4	43.41	-3.0	46.50	4.5	45.00	-1.3	48.50
2	5.9	44.05	-2.7	47.90	5.4	45.00	-2.8	48.80
3	87.2	45.00	-0.0	49.75	35.1	47.00	-35.6	43.85
4	No calculation at this stage							
5	82.0	45.00	-0.0	49.75	29.4	47.00	-33.0	43.85
6	46.1	42.50	-115.5	45.50	85.4	43.41	-100.3	48.20
7	47.1	42.50	-116.4	45.50	87.1	43.41	-100.7	48.20
8	No calculation at this stage							
9	46.5	42.50	-103.3	46.00	72.2	44.05	-94.4	48.20
10	151.6	44.05	-59.6	46.50	181.4	44.05	-140.7	44.05
11	No calculation at this stage							
12	131.1	44.05	-63.5	46.50	173.6	44.05	-97.7	44.05

Summary of results (continued)

Maximum and minimum displacement at each stage

Stage no.	Displacement maximum m	Displacement elev.	Displacement minimum m	Displacement elev.	Stage description
1	0.001	49.75	0.000	49.75	Apply surcharge no.1 at elev. 49.75
2	0.002	49.75	0.000	49.75	Apply water pressure profile no.1
3	0.023	49.75	0.000	49.75	Excav. to elev. 47.90 on RIGHT side
4	No calculation at this stage				Install strut no.1 at elev. 48.20
5	0.023	49.75	0.000	49.75	Apply water pressure profile no.2
6	0.017	46.50	0.000	49.75	Excav. to elev. 43.41 on RIGHT side
7	0.017	46.50	0.000	49.75	Fill to elev. 43.85 on RIGHT side
8	No calculation at this stage				Install strut no.2 at elev. 44.05
9	0.018	46.50	0.000	49.75	Change EI of wall to 43355kN.m2/m run
10	0.021	40.75	0.000	49.75	Change soil type 3 to soil type 4
11	No calculation at this stage				Apply surcharge no.2 at elev. 43.85
12	0.020	40.75	0.000	49.75	Apply water pressure profile no.3

Strut forces at each stage (horizontal components)

Stage no.	Strut no. 1 at elev. 48.20		Strut no. 2 at elev. 44.05	
	kN/m run	kN/strut	kN/m run	kN/strut
5	7.45	7.45	---	---
6	142.21	142.21	---	---
7	142.57	142.57	---	---
9	137.04	137.04	25.11	25.11
10	111.19	111.19	322.05	322.05
12	114.45	114.45	271.37	271.37

Units: kN,m

Bending moment, shear force, displacement envelopes

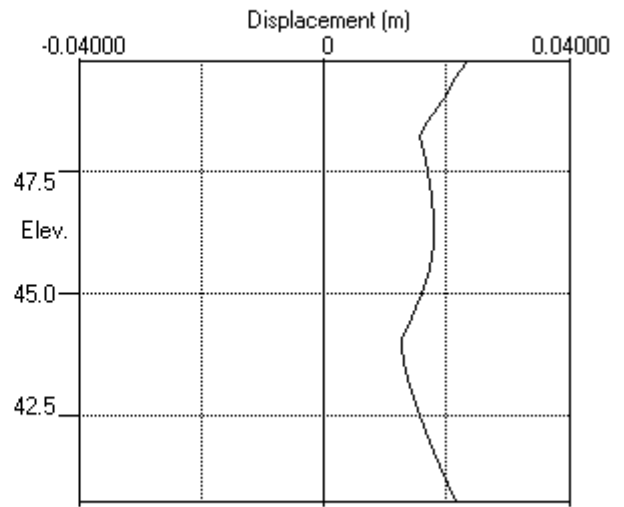
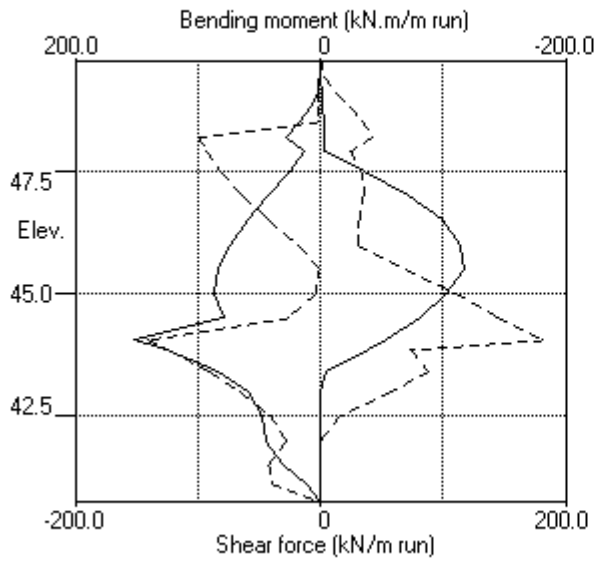



WALLAP

2-SLS

PILEDESIGNS LTD
 Program: WALLAP Version 6.06 Revision A51.B69.R54
 Licensed from GEOSOLVE
 Data filename/Run ID: Hampstead_Wall_2_450mm_rev_01_SLS
 Hampstead - 24-26 Redington Gardens
 Wall 5, Secant-SLS, 450 dia @ 650 - run 01

Sheet No.
 Job No. 21495
 Made by : DBS
 Date: 1-10-2018
 Checked :

Units: kN,m

INPUT DATA

SOIL PROFILE

Stratum no.	Elevation of top of stratum	Soil types	
		Left side	Right side
1	49.75	1 Made Ground dr	1 Made Ground dr
2	47.50	2 Claygate Clay dr	2 Claygate Clay dr
3	45.00	3 London Clay und	3 London Clay und

SOIL PROPERTIES

No. Description (Datum elev.)	Bulk density kN/m3	Young's Modulus Eh, kN/m2 (dEh/dy)	At rest coeff. Ko (dKo/dy)	Consol state. NC/OC (Nu)	Active limit Ka (Kac)	Passive limit Kp (Kpc)	Cohesion kN/m2 (dc/dy)
1 Made Ground dr	18.00	10000	0.530	OC (0.250)	0.337 (0.000)	3.442 (0.000)	
2 Claygate Clay dr	19.00	30000	1.000	NC (0.200)	0.323 (1.330)	3.647 (5.195)	0.0d
3 London Cl.. (45.00)	20.00	40000 (4000)	1.000	OC (0.490)	1.000 (2.476)	1.000 (2.390)	50.00u (5.000)
4 London Cl.. (45.00)	20.00	30800 (3080)	1.000	OC (0.200)	0.351 (1.391)	3.253 (4.831)	0.0d

Additional soil parameters associated with Ka and Kp

No. Description	--- parameters for Ka ---			--- parameters for Kp ---		
	Soil friction angle	Wall adhesion coeff.	Back-fill angle	Soil friction angle	Wall adhesion coeff.	Back-fill angle
1 Made Ground dr	26.00	0.670	0.00	26.00	0.500	0.00
2 Claygate Clay dr	27.00	0.670	0.00	27.00	0.500	0.00
3 London Clay und	0.00	0.670	0.00	0.00	0.500	0.00
4 London Clay dr	25.00	0.670	0.00	25.00	0.500	0.00

GROUND WATER CONDITIONS

Density of water = 9.810 kN/m3

	Left side	Right side
Initial water table elevation	49.40	49.40

Automatic water pressure balancing at toe of wall : No

Water profile no.	Left side				Right side			
	Point no.	Elev. m	Piezo elev. m	Water press. kN/m2	Point no.	Elev. m	Piezo elev. m	Water press. kN/m2
1	1	49.40	49.40	0.0	1	47.50	47.50	0.0 MC+WC
2	1	49.40	49.40	0.0	1	43.00	43.00	0.0 MC+WC
3	1	49.40	49.40	0.0	1	43.85	43.85	0.0 MC+WC
					2	43.85	49.40	54.4

WALL PROPERTIES

Type of structure = Fully Embedded Wall
 Elevation of toe of wall = 40.75
 Maximum finite element length = 0.50 m
 Youngs modulus of wall E = 1.9600E+07 kN/m2
 Moment of inertia of wall I = 3.0968E-03 m4/m run
 E.I = 60696 kN.m2/m run
 Yield Moment of wall = Not defined

STRUTS and ANCHORS

Strut/ anchor no.	Elev.	Strut spacing m	X-section area of strut sq.m	Youngs modulus kN/m ²	Free length m	Inclin -ation (degs)	Pre- stress /strut kN	Tension allowed
1	48.20	1.00	0.300000	1.400E+07	5.00	0.00	0	No
2	44.05	1.00	0.300000	1.400E+07	5.00	0.00	0	No

SURCHARGE LOADS

Surch -arge no.	Elev.	Distance from wall	Length parallel to wall	Width perpend. to wall	Surcharge ----- kN/m ² ----- Near edge Far edge		Equiv. soil type	Partial factor/ Category
1	49.75	0.50(L)	10.00	10.00	13.00	=	N/A	1.00 Var
2	43.85	-0.00(R)	10.00	10.00	55.00	=	N/A	1.00 P/F

Note: L = Left side, R = Right side

Limit State Categories P/U = Permanent Unfavourable
P/F = Permanent Favourable
Var = Variable (unfavourable)

CONSTRUCTION STAGES

Construction stage no.	Stage description
1	Apply surcharge no.1 at elevation 49.75
2	Apply water pressure profile no.1 (Mod. Conserv.)
3	Excavate to elevation 47.90 on RIGHT side
4	Install strut or anchor no.1 at elevation 48.20
5	Apply water pressure profile no.2 (Mod. Conserv.)
6	Excavate to elevation 43.85 on RIGHT side
7	Install strut or anchor no.2 at elevation 44.05
8	Change EI of wall to 43355 kN.m ² /m run Yield moment not defined Allow wall to relax with new modulus value
9	Change properties of soil type 3 to soil type 4 Ko pressures will not be reset
10	Apply surcharge no.2 at elevation 43.85 No analysis at this stage
11	Apply water pressure profile no.3 (Mod. Conserv.)

FACTORS OF SAFETY and ANALYSIS OPTIONS

Limit State options: Serviceability Limit State
All loads and soil strengths are unfactored

Stability analysis:

Method of analysis - Strength Factor method
Factor on soil strength for calculating wall depth = 1.50

Parameters for undrained strata:

Minimum equivalent fluid density = 5.00 kN/m³
Maximum depth of water filled tension crack = 0.00 m

Bending moment and displacement calculation:

Method - Subgrade reaction model using Influence Coefficients
Open Tension Crack analysis? - No
Non-linear Modulus Parameter (L) = 9.000 m

Boundary conditions:

Length of wall (normal to plane of analysis) = 50.00 m

Width of excavation on Left side of wall = 50.00 m
Width of excavation on Right side of wall = 50.00 m

Distance to rigid boundary on Left side = 50.00 m
Distance to rigid boundary on Right side = 50.00 m

OUTPUT OPTIONS

Stage no.	Stage description	Displacement	Active, Passive pressures	Graph. output
1	Apply surcharge no.1 at elev. 49.75	No	No	No
2	Apply water pressure profile no.1	Yes	Yes	Yes
3	Excav. to elev. 47.90 on RIGHT side	Yes	Yes	Yes
4	Install strut no.1 at elev. 48.20	Yes	Yes	Yes
5	Apply water pressure profile no.2	Yes	Yes	Yes
6	Excav. to elev. 43.85 on RIGHT side	Yes	Yes	Yes
7	Install strut no.2 at elev. 44.05	Yes	Yes	Yes
8	Change EI of wall to 43355kN.m ² /m run	No	No	No
9	Change soil type 3 to soil type 4	No	No	No
10	Apply surcharge no.2 at elev. 43.85	No	No	No
11	Apply water pressure profile no.3	No	No	No
*	Summary output	Yes	-	Yes

Program WALLAP - Copyright (C) 2017 by DL Borin, distributed by GEOSOLVE
150 St. Alphonsus Road, London SW4 7BW, UK www.geosolve.co.uk

PILEDESIGNS LTD
 Program: WALLAP Version 6.06 Revision A51.B69.R54
 Licensed from GEOSOLVE
 Data filename/Run ID: Hampstead_Wall_2_450mm_rev_01_SLS
 Hampstead - 24-26 Redington Gardens
 Wall 5, Secant-SLS, 450 dia @ 650 - run 01

Sheet No.
 Job No. 21495
 Made by : DBS
 Date: 1-10-2018
 Checked :

Units: kN,m

Stage No. 3 Excavate to elevation 47.90 on RIGHT side

STABILITY ANALYSIS of Fully Embedded Wall according to Strength Factor method
 Factor of safety on soil strength

Stage No.	--- G.L. --- Act.	--- G.L. --- Pass.	Strut Elev.	FoS for toe elev. =	Moment of equil. at elev.	Toe elev. for FoS =	Wall Penetr-ation	Direction of failure
3	49.75	47.90	Cant.	2.273	41.81	42.61	5.29	L to R

BENDING MOMENT and DISPLACEMENT ANALYSIS of Fully Embedded Wall

Analysis options

Length of wall perpendicular to section = 50.00m

Subgrade reaction model - Boussinesq Influence coefficients

Soil deformations are elastic until the active or passive limit is reached

Open Tension Crack analysis - No

Rigid boundaries: Left side 50.00 from wall
 Right side 50.00 from wall

Limit State: Serviceability Limit State

Calculated Bending Moments and Strut Forces are to be multiplied by a factor of 1.35 to obtain values for structural design. See summary for factored values.

Node no.	Y coord	Nett pressure kN/m ²	Wall disp. m	Wall rotation rad.	Shear force kN/m	Bending moment kN.m/m	Strut forces kN/m	EI of wall kN.m ² /m
1	49.75	0.00	0.011	2.58E-03	0.0	-0.0		60696
2	49.40	2.51	0.010	2.58E-03	0.4	0.1		60696
3	49.10	7.09	0.009	2.58E-03	1.9	0.5		60696
4	48.80	11.53	0.009	2.57E-03	4.7	1.4		60696
5	48.50	15.76	0.008	2.56E-03	8.8	3.4		60696
6	48.20	19.85	0.007	2.53E-03	14.1	6.8		60696
7	47.90	23.83	0.006	2.49E-03	20.7	12.0		60696
8	47.50	4.26	0.005	2.38E-03	26.3	21.6		60696
		2.35	0.005	2.38E-03	26.3	21.6		
9	47.00	-12.81	0.004	2.15E-03	23.7	34.4		60696
10	46.50	-28.04	0.003	1.82E-03	13.5	43.9		60696
11	46.00	-28.49	0.002	1.44E-03	-0.7	48.6		60696
12	45.50	-14.60	0.002	1.06E-03	-11.5	44.7		60696
13	45.00	-5.32	0.001	7.27E-04	-16.4	37.1		60696
		-8.62	0.001	7.27E-04	-16.4	37.1		
14	44.53	0.71	0.001	4.71E-04	-18.3	28.3		60696
15	44.05	5.87	0.001	2.83E-04	-16.7	19.7		60696
16	43.85	7.07	0.001	2.23E-04	-15.5	16.5		60696
17	43.42	8.15	0.001	1.29E-04	-12.2	10.5		60696
18	43.00	7.84	0.001	7.15E-05	-8.8	6.0		60696
19	42.50	6.44	0.001	3.59E-05	-5.3	2.6		60696
20	42.00	4.55	0.001	2.20E-05	-2.5	0.8		60696
21	41.50	2.52	0.001	1.85E-05	-0.7	0.1		60696
22	41.13	0.98	0.001	1.84E-05	-0.1	-0.0		60696
23	40.75	-0.55	0.001	1.85E-05	0.0	0.0		---

(continued)

Stage No.3 Excavate to elevation 47.90 on RIGHT side

Node no.	Y coord	LEFT side					Total earth pressure kN/m2	Coeff. of subgrade reaction kN/m3
		Water press. kN/m2	Vertic -al kN/m2	Effective Active limit kN/m2	Effective Passive limit kN/m2	Earth pressure kN/m2		
1	49.75	0.00	0.00	0.00	0.00	0.00	0.00	3621
2	49.40	0.00	7.46	2.51	25.69	2.51	2.51a	3621
3	49.10	2.94	12.32	4.15	42.41	4.15	7.09a	3621
4	48.80	5.89	16.76	5.64	57.69	5.64	11.53a	3621
5	48.50	8.83	20.59	6.93	70.88	6.93	15.76a	3621
6	48.20	11.77	23.99	8.08	82.57	8.08	19.85a	3621
7	47.90	14.71	27.09	9.12	93.24	9.12	23.83a	3621
8	47.50	18.64	30.91	10.41	106.41	10.41	29.05a	3621
		18.64	30.91	9.97	112.74	9.97	28.61a	10452
9	47.00	23.54	35.87	11.57	130.80	11.57	35.11a	10452
10	46.50	28.45	40.58	13.09	148.00	13.09	41.54a	10452
11	46.00	33.35	45.14	14.56	164.60	23.05	56.40	10452
12	45.50	38.26	49.58	15.99	180.81	33.73	71.99	10452
13	45.00	43.16	53.95	17.40	196.74	42.41	85.58	10452
		Total>	97.11	23.75m	216.61	74.07	74.07	20145
14	44.53	Total>	106.35	26.12m	231.52	87.60	87.60	21101
15	44.05	Total>	115.56	28.50m	246.41	99.30	99.30	22058
16	43.85	Total>	119.43	29.50m	252.67	103.79	103.79	22461
17	43.42	Total>	127.65	31.63m	265.97	112.70	112.70	23317
18	43.00	Total>	135.87	33.75m	279.27	120.99	120.99	24174
19	42.50	Total>	145.53	36.25m	294.91	130.28	130.28	25181
20	42.00	Total>	155.20	38.75m	310.55	139.34	139.34	26188
21	41.50	Total>	164.88	41.25m	326.20	148.34	148.34	27195
22	41.13	Total>	172.14	43.13m	337.94	155.08	155.08	27951
23	40.75	Total>	177.00	45.00m	347.28	161.84	161.84	28706

Node no.	Y coord	RIGHT side					Total earth pressure kN/m2	Coeff. of subgrade reaction kN/m3
		Water press. kN/m2	Vertic -al kN/m2	Effective Active limit kN/m2	Effective Passive limit kN/m2	Earth pressure kN/m2		
1	49.75	0.00	0.00	0.00	0.00	0.00	0.00	0.0
2	49.40	0.00	0.00	0.00	0.00	0.00	0.00	0.0
3	49.10	0.00	0.00	0.00	0.00	0.00	0.00	0.0
4	48.80	0.00	0.00	0.00	0.00	0.00	0.00	0.0
5	48.50	0.00	0.00	0.00	0.00	0.00	0.00	0.0
6	48.20	0.00	0.00	0.00	0.00	0.00	0.00	0.0
7	47.90	0.00	0.00	0.00	0.00	0.00	0.00	0.0
		0.00	0.00	0.00	0.00	0.00	0.00	4872
8	47.50	0.00	7.20	2.42	24.78	24.78	24.78p	4872
		0.00	7.20	2.32	26.26	26.26	26.26p	14092
9	47.00	4.90	11.80	3.80	43.02	43.02	47.92p	14092
10	46.50	9.81	16.39	5.29	59.77	59.77	69.58p	14092
11	46.00	14.71	20.99	6.77	76.53	70.18	84.89	14092
12	45.50	19.62	25.58	8.25	93.29	66.97	86.59	14092
13	45.00	24.52	30.18	9.73	110.05	66.38	90.90	14092
		Total>	54.70	14.50m	174.20	82.69	82.69	26640
14	44.53	Total>	64.20	16.88m	189.38	86.89	86.89	27905
15	44.05	Total>	73.71	19.25m	204.56	93.42	93.42	29171
16	43.85	Total>	77.71	20.25m	210.95	96.73	96.73	29703
17	43.42	Total>	86.21	22.38m	224.53	104.55	104.55	30836
18	43.00	Total>	94.71	24.50m	238.11	113.15	113.15	31968
19	42.50	Total>	104.72	27.00m	254.09	123.83	123.83	33300
20	42.00	Total>	114.72	29.50m	270.07	134.79	134.79	34632

(continued)

Stage No.3 Excavate to elevation 47.90 on RIGHT side

Node no.	Y coord	----- Effective stresses -----					Total earth pressure	Coeff. of subgrade reaction
		Water press. kN/m2	Vertic -al kN/m2	Active limit kN/m2	Passive limit kN/m2	Earth pressure kN/m2		
21	41.50	Total>	124.73	32.00m	286.05	145.82	145.82	35964
22	41.13	Total>	132.23	33.88m	298.04	154.10	154.10	36963
23	40.75	Total>	139.74	35.75m	310.02	162.38	162.38	37962

Note: 41.54a Soil pressure at active limit
 69.58p Soil pressure at passive limit

Units: kN,m

Stage No.3 Excav. to elev. 47.90 on RIGHT side

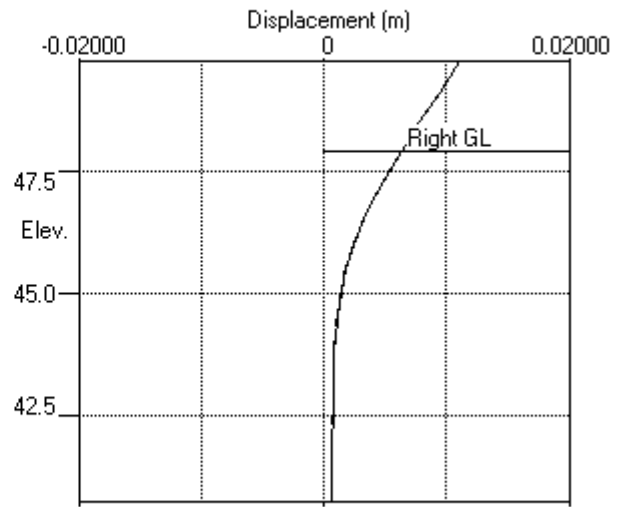
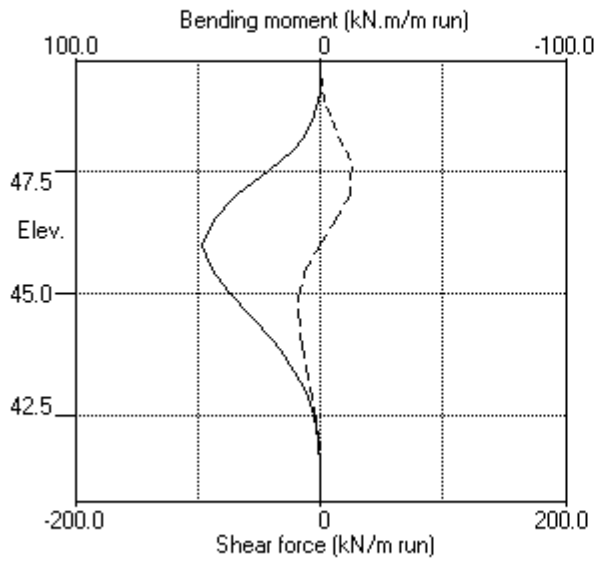

Stage No.3 Excav. to elev. 47.90 on RIGHT side

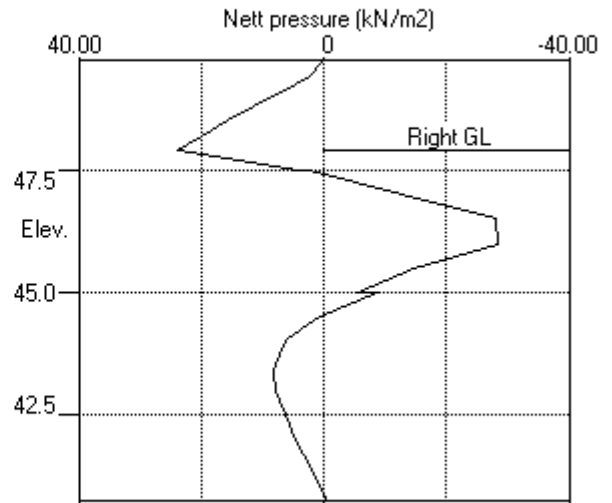
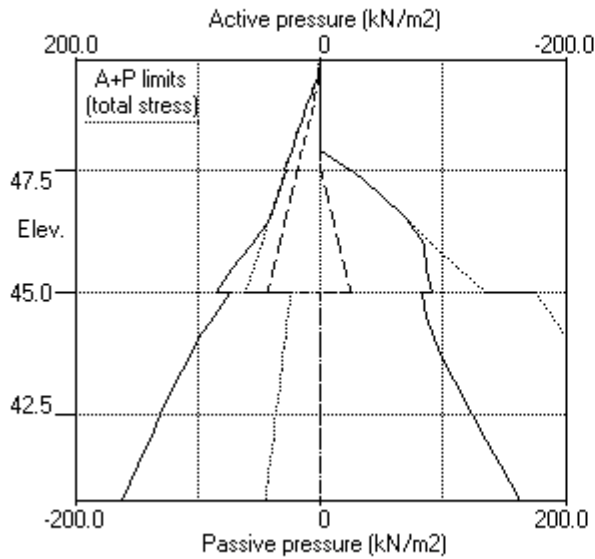

(continued)

Stage No.6 Excavate to elevation 43.85 on RIGHT side

Node no.	Y coord	LEFT side					Total earth pressure kN/m2	Coeff. of subgrade reaction kN/m3
		Water press. kN/m2	Vertic -al kN/m2	Effective Active limit kN/m2	Effective Passive limit kN/m2	Earth pressure kN/m2		
1	49.75	0.00	0.00	0.00	0.00	0.00	0.00	6823
2	49.40	0.00	7.46	2.51	25.69	25.69	25.69p	6823
3	49.10	2.94	12.32	4.15	42.41	25.44	28.38	6823
4	48.80	5.89	16.76	5.64	57.69	19.61	25.50	6823
5	48.50	8.83	20.59	6.93	70.88	13.51	22.34	6823
6	48.20	11.77	23.99	8.08	82.57	8.08	19.85a	2390
7	47.90	14.71	27.09	9.12	93.24	9.12	23.83a	2390
8	47.50	18.64	30.91	10.41	106.41	10.41	29.05a	2390
		18.64	30.91	9.97	112.74	9.97	28.61a	6868
9	47.00	23.54	35.87	11.57	130.80	11.57	35.11a	6868
10	46.50	28.45	40.58	13.09	148.00	13.09	41.54a	6868
11	46.00	33.35	45.14	14.56	164.60	14.56	47.91a	6868
12	45.50	38.26	49.58	15.99	180.81	15.99	54.25a	6868
13	45.00	43.16	53.95	17.40	196.74	17.40	60.57a	6868
		Total>	97.11	23.75m	216.61	23.75	23.75a	13819
14	44.53	Total>	106.35	26.12m	231.52	26.12	26.12a	14476
15	44.05	Total>	115.56	28.50m	246.41	28.50	28.50a	15132
16	43.85	Total>	119.43	29.50m	252.67	31.01	31.01	15409
17	43.42	Total>	127.65	31.63m	265.97	50.45	50.45	15996
18	43.00	Total>	135.87	33.75m	279.27	69.18	69.18	16583
19	42.50	Total>	145.53	36.25m	294.91	89.59	89.59	17274
20	42.00	Total>	155.20	38.75m	310.55	108.31	108.31	17965
21	41.50	Total>	164.88	41.25m	326.20	125.95	125.95	18656
22	41.13	Total>	172.14	43.13m	337.94	138.98	138.98	19174
23	40.75	Total>	177.00	45.00m	347.28	152.71	152.71	19693

Node no.	Y coord	RIGHT side					Total earth pressure kN/m2	Coeff. of subgrade reaction kN/m3
		Water press. kN/m2	Vertic -al kN/m2	Effective Active limit kN/m2	Effective Passive limit kN/m2	Earth pressure kN/m2		
1	49.75	0.00	0.00	0.00	0.00	0.00	0.00	0.0
2	49.40	0.00	0.00	0.00	0.00	0.00	0.00	0.0
3	49.10	0.00	0.00	0.00	0.00	0.00	0.00	0.0
4	48.80	0.00	0.00	0.00	0.00	0.00	0.00	0.0
5	48.50	0.00	0.00	0.00	0.00	0.00	0.00	0.0
6	48.20	0.00	0.00	0.00	0.00	0.00	0.00	0.0
7	47.90	0.00	0.00	0.00	0.00	0.00	0.00	0.0
8	47.50	0.00	0.00	0.00	0.00	0.00	0.00	0.0
9	47.00	0.00	0.00	0.00	0.00	0.00	0.00	0.0
10	46.50	0.00	0.00	0.00	0.00	0.00	0.00	0.0
11	46.00	0.00	0.00	0.00	0.00	0.00	0.00	0.0
12	45.50	0.00	0.00	0.00	0.00	0.00	0.00	0.0
13	45.00	0.00	0.00	0.00	0.00	0.00	0.00	0.0
14	44.53	0.00	0.00	0.00	0.00	0.00	0.00	0.0
15	44.05	0.00	0.00	0.00	0.00	0.00	0.00	0.0
16	43.85	0.00	0.00	0.00	0.00	0.00	0.00	0.0
		Total>	0.00	0.00	133.24	133.24	133.24p	28177
17	43.42	Total>	8.50	2.12m	146.82	140.22	140.22	29251
18	43.00	Total>	17.00	4.25m	160.40	129.99	129.99	30325
19	42.50	Total>	27.00	6.75m	176.37	120.75	120.75	31589
20	42.00	Total>	37.00	9.25m	192.35	114.40	114.40	32852
21	41.50	Total>	47.00	11.75m	208.33	109.93	109.93	34116
22	41.13	Total>	54.51	13.62m	220.31	106.92	106.92	35063

Run ID. Hampstead_Wall_2_450mm_rev_01_SLS
 Hampstead - 24-26 Redington Gardens
 Wall 5, Secant-SLS, 450 dia @ 650 - run 01

| Sheet No.
 | Date: 1-10-2018
 | Checked :

(continued)

Stage No.6 Excavate to elevation 43.85 on RIGHT side

Node no.	Y coord	----- Effective stresses -----					Total earth pressure	Coeff. of subgrade reaction
		Water press. kN/m ²	Vertic -al kN/m ²	Active limit kN/m ²	Passive limit kN/m ²	Earth pressure kN/m ²		
23	40.75	Total>	62.01	15.50m	232.29	103.09	103.09	36011

Note: 28.50a Soil pressure at active limit
 133.24p Soil pressure at passive limit

Units: kN,m

Stage No.6 Excav. to elev. 43.85 on RIGHT side

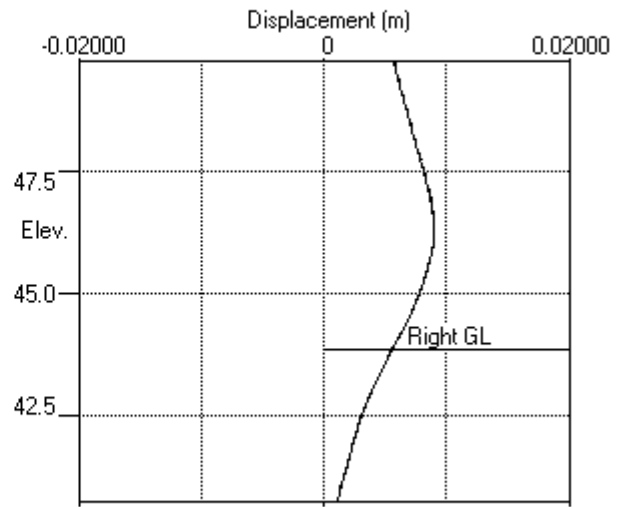
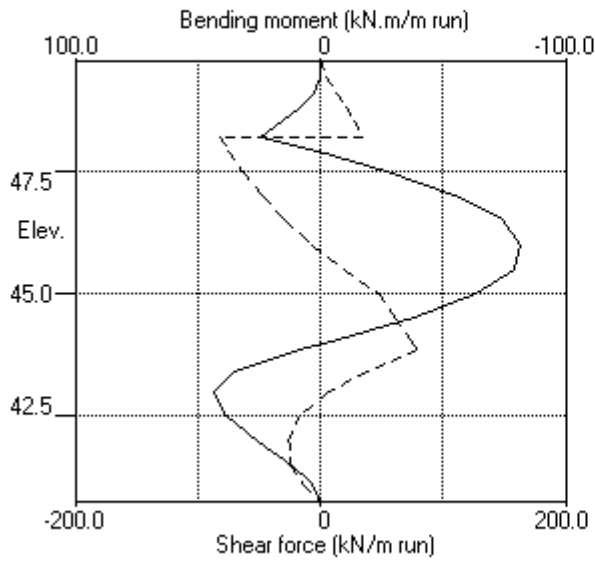

Stage No.6 Excav. to elev. 43.85 on RIGHT side

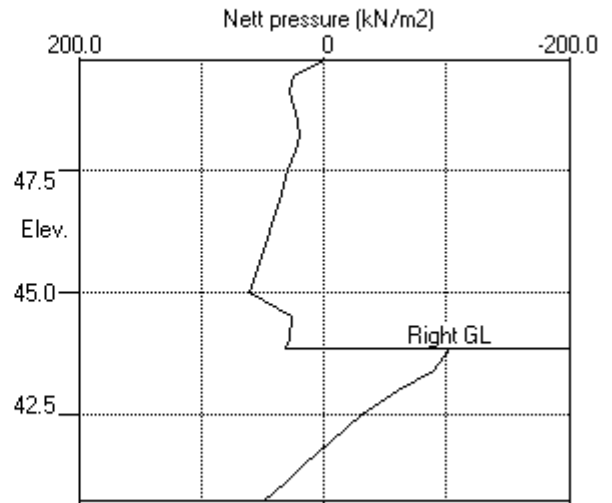
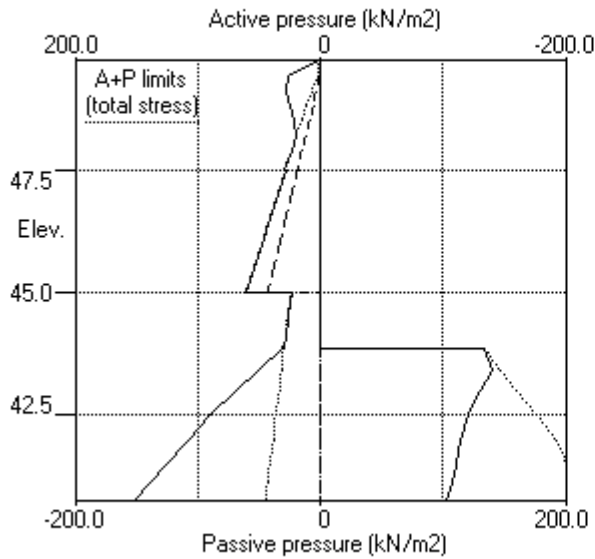

PILEDESIGNS LTD	Sheet No.
Program: WALLAP Version 6.06 Revision A51.B69.R54	Job No. 21495
Licensed from GEOSOLVE	Made by : DBS
Data filename/Run ID: Hampstead_Wall_2_450mm_rev_01_SLS	Date: 1-10-2018
Hampstead - 24-26 Redington Gardens	Checked :
Wall 5, Secant-SLS, 450 dia @ 650 - run 01	

Units: kN,m

Stage No. 8 Change EI of wall to 43355 kN.m²/m run
 Yield moment not defined
 Allow wall to relax with new modulus value

STABILITY ANALYSIS of Fully Embedded Wall according to Strength Factor method

Factor of safety on soil strength

			FoS for toe elev. = 40.75	Toe elev. for FoS = 1.500		
Stage No.	--- G.L. Act.	--- Pass.	Strut Elev.	Factor of Safety	Moment of equil. at elev.	Toe Wall Penetr-ation elev. Direction of failure
8	49.75	43.85				More than one strut. No FoS calc.

BENDING MOMENT and DISPLACEMENT ANALYSIS of Fully Embedded Wall

Analysis options

Length of wall perpendicular to section = 50.00m
 Subgrade reaction model - Boussinesq Influence coefficients
 Soil deformations are elastic until the active or passive limit is reached
 Open Tension Crack analysis - No

Rigid boundaries: Left side 50.00 from wall
 Right side 50.00 from wall

Limit State: Serviceability Limit State

Calculated Bending Moments and Strut Forces are to be multiplied by a factor of 1.35 to obtain values for structural design. See summary for factored values.

Node no.	Y coord	Nett pressure kN/m ²	Wall disp. m	Wall rotation rad.	Shear force kN/m	Bending moment kN.m/m	Strut forces kN/m	EI of wall kN.m ² /m
1	49.75	0.00	0.005	-1.26E-03	0.0	-0.0		43355
2	49.40	25.69	0.006	-1.26E-03	4.5	0.6		43355
3	49.10	30.27	0.006	-1.28E-03	12.9	2.8		43355
4	48.80	26.81	0.006	-1.31E-03	21.5	8.1		43355
5	48.50	23.03	0.007	-1.40E-03	28.9	15.7		43355
6	48.20	19.86	0.007	-1.54E-03	35.4	25.4	113.9	43355
		19.86	0.007	-1.54E-03	-78.6	25.4		
7	47.90	23.83	0.008	-1.64E-03	-72.0	2.7		43355
8	47.50	29.05	0.008	-1.54E-03	-61.4	-24.4		43355
		28.61	0.008	-1.54E-03	-61.4	-24.4		
9	47.00	35.11	0.009	-1.12E-03	-45.5	-51.5		43355
10	46.50	41.54	0.009	-4.31E-04	-26.3	-70.0		43355
11	46.00	47.91	0.009	3.96E-04	-4.0	-76.4		43355
12	45.50	54.25	0.009	1.23E-03	21.6	-73.0		43355
13	45.00	60.57	0.008	1.96E-03	50.3	-55.9		43355
		23.75	0.008	1.96E-03	50.3	-55.9		
14	44.53	26.12	0.007	2.40E-03	62.1	-30.0		43355
15	44.05	28.50	0.006	2.53E-03	75.1	2.0	16.4	43355
		28.50	0.006	2.53E-03	58.6	2.0		
16	43.85	32.06	0.006	2.48E-03	64.7	15.4		43355
		-100.14	0.006	2.48E-03	64.7	15.4		
17	43.42	-82.76	0.005	2.20E-03	25.8	38.4		43355
18	43.00	-51.30	0.004	1.80E-03	-2.7	42.8		43355
19	42.50	-21.69	0.003	1.35E-03	-20.9	35.7		43355
20	42.00	0.89	0.002	1.02E-03	-26.1	22.7		43355
21	41.50	19.07	0.002	8.47E-04	-21.1	9.4		43355
22	41.13	30.61	0.002	7.99E-04	-11.8	2.5		43355
23	40.75	32.30	0.001	7.89E-04	0.0	0.0		---

At elev. 48.20 Strut force = 113.9 kN/strut = 113.9 kN/m run
 At elev. 44.05 Strut force = 16.4 kN/strut = 16.4 kN/m run

(continued)

Stage No.8 Change EI of wall to 43355 kN.m2/m run
Yield moment not defined
Allow wall to relax with new modulus value

Node no.	Y coord	LEFT side					Total earth pressure	Coeff. of subgrade reaction
		Water press.	Vertic -al	Effective Active limit	Effective Passive limit	Earth pressure		
		kN/m2	kN/m2	kN/m2	kN/m2	kN/m2	kN/m2	kN/m3
1	49.75	0.00	0.00	0.00	0.00	0.00	0.00	6476
2	49.40	0.00	7.46	2.51	25.69	25.69	25.69p	6476
3	49.10	2.94	12.32	4.15	42.41	27.33	30.27	6476
4	48.80	5.89	16.76	5.64	57.69	20.92	26.81	6476
5	48.50	8.83	20.59	6.93	70.88	14.20	23.03	6476
6	48.20	11.77	23.99	8.08	82.57	8.09	19.86	6476
7	47.90	14.71	27.09	9.12	93.24	9.12	23.83a	3050
8	47.50	18.64	30.91	10.41	106.41	10.41	29.05a	3050
		18.64	30.91	9.97	112.74	9.97	28.61a	8789
9	47.00	23.54	35.87	11.57	130.80	11.57	35.11a	8789
10	46.50	28.45	40.58	13.09	148.00	13.09	41.54a	8789
11	46.00	33.35	45.14	14.56	164.60	14.56	47.91a	8789
12	45.50	38.26	49.58	15.99	180.81	15.99	54.25a	8789
13	45.00	43.16	53.95	17.40	196.74	17.40	60.57a	8789
		Total>	97.11	23.75m	216.61	23.75	23.75a	17192
14	44.53	Total>	106.35	26.12m	231.52	26.12	26.12a	18008
15	44.05	Total>	115.56	28.50m	246.41	28.50	28.50a	18825
16	43.85	Total>	119.43	29.50m	252.67	32.06	32.06	23407
17	43.42	Total>	127.65	31.63m	265.97	53.96	53.96	24299
18	43.00	Total>	135.87	33.75m	279.27	73.94	73.94	25191
19	42.50	Total>	145.53	36.25m	294.91	94.32	94.32	26241
20	42.00	Total>	155.20	38.75m	310.55	111.80	111.80	27290
21	41.50	Total>	164.88	41.25m	326.20	127.47	127.47	28340
22	41.13	Total>	172.14	43.13m	337.94	138.26	138.26	129923
23	40.75	Total>	177.00	45.00m	347.28	144.05	144.05	133435

Node no.	Y coord	RIGHT side					Total earth pressure	Coeff. of subgrade reaction
		Water press.	Vertic -al	Effective Active limit	Effective Passive limit	Earth pressure		
		kN/m2	kN/m2	kN/m2	kN/m2	kN/m2	kN/m2	kN/m3
1	49.75	0.00	0.00	0.00	0.00	0.00	0.00	0.0
2	49.40	0.00	0.00	0.00	0.00	0.00	0.00	0.0
3	49.10	0.00	0.00	0.00	0.00	0.00	0.00	0.0
4	48.80	0.00	0.00	0.00	0.00	0.00	0.00	0.0
5	48.50	0.00	0.00	0.00	0.00	0.00	0.00	0.0
6	48.20	0.00	0.00	0.00	0.00	0.00	0.00	0.0
7	47.90	0.00	0.00	0.00	0.00	0.00	0.00	0.0
8	47.50	0.00	0.00	0.00	0.00	0.00	0.00	0.0
9	47.00	0.00	0.00	0.00	0.00	0.00	0.00	0.0
10	46.50	0.00	0.00	0.00	0.00	0.00	0.00	0.0
11	46.00	0.00	0.00	0.00	0.00	0.00	0.00	0.0
12	45.50	0.00	0.00	0.00	0.00	0.00	0.00	0.0
13	45.00	0.00	0.00	0.00	0.00	0.00	0.00	0.0
14	44.53	0.00	0.00	0.00	0.00	0.00	0.00	0.0
15	44.05	0.00	0.00	0.00	0.00	0.00	0.00	0.0
16	43.85	0.00	0.00	0.00	0.00	0.00	0.00	0.0
		Total>	0.00	0.00	133.24	132.19	132.19	23407
17	43.42	Total>	8.50	2.12m	146.82	136.71	136.71	24299
18	43.00	Total>	17.00	4.25m	160.40	125.23	125.23	25191
19	42.50	Total>	27.00	6.75m	176.37	116.02	116.02	26241
20	42.00	Total>	37.00	9.25m	192.35	110.91	110.91	27290

(continued)

Stage No.8 Change EI of wall to 43355 kN.m2/m run
 Yield moment not defined
 Allow wall to relax with new modulus value

Node no.	Y coord	----- RIGHT side -----						Total earth pressure	Coeff. of subgrade reaction
		Water press.	Vertic -al	Effective Active limit	Effective Passive limit	Earth pressure	Earth pressure		
		kN/m2	kN/m2	kN/m2	kN/m2	kN/m2	kN/m2	kN/m3	
21	41.50	Total>	47.00	11.75m	208.33	108.40	108.40	28340	
22	41.13	Total>	54.51	13.62m	220.31	107.65	107.65	129923	
23	40.75	Total>	62.01	15.50m	232.29	111.75	111.75	133435	

Note: 28.50a Soil pressure at active limit
 25.69p Soil pressure at passive limit

Units: kN,m

Stage No.8 Change EI of wall to 43355kN.m2/m run

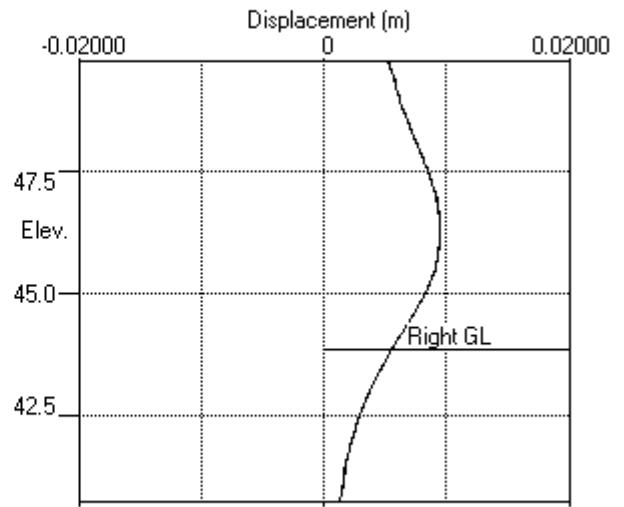
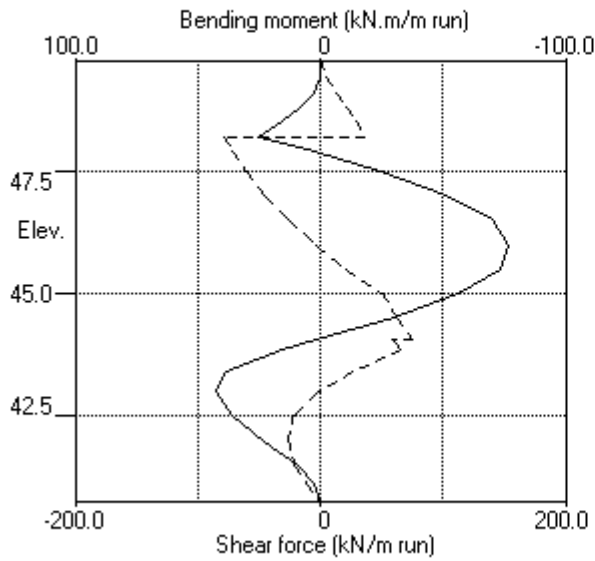

Stage No.8 Change EI of wall to 43355kN.m2/m run

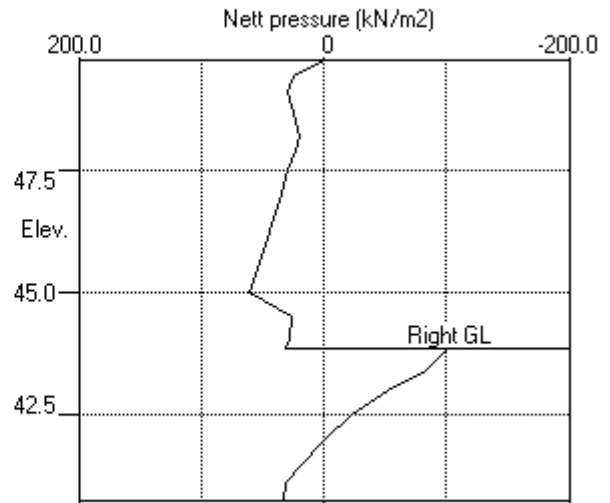
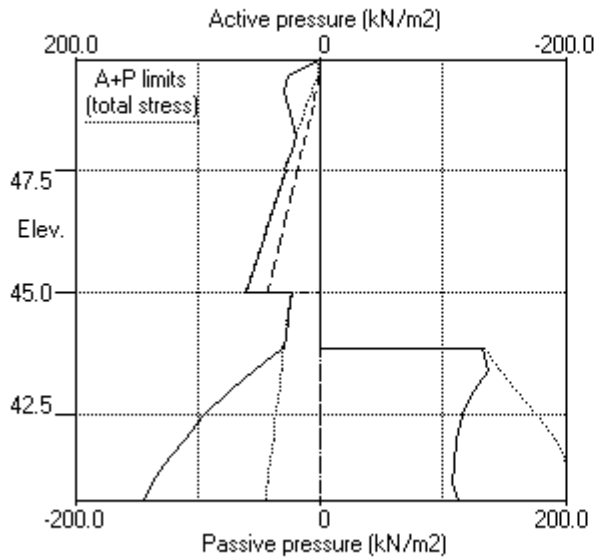

PILEDESIGNS LTD
 Program: WALLAP Version 6.06 Revision A51.B69.R54
 Licensed from GEOSOLVE
 Data filename/Run ID: Hampstead_Wall_2_450mm_rev_01_SLS
 Hampstead - 24-26 Redington Gardens
 Wall 5, Secant-SLS, 450 dia @ 650 - run 01

Sheet No.
 Job No. 21495
 Made by : DBS
 Date: 1-10-2018
 Checked :

Units: kN,m

Stage No. 9 Change properties of soil type 3 to soil type 4
 Ko pressures will not be reset

STABILITY ANALYSIS of Fully Embedded Wall according to Strength Factor method
 Factor of safety on soil strength

Stage No.	--- G.L. --- Act. Pass.	Strut Elev.	FoS for toe elev. = 40.75	Moment of equil. at elev.	Toe elev. for FoS = 1.500	Wall Penetr -ation	Direction of failure
9	49.75 43.85			More than one strut.	No FoS calc.		

BENDING MOMENT and DISPLACEMENT ANALYSIS of Fully Embedded Wall

Analysis options

Length of wall perpendicular to section = 50.00m
 Subgrade reaction model - Boussinesq Influence coefficients
 Soil deformations are elastic until the active or passive limit is reached
 Open Tension Crack analysis - No

Rigid boundaries: Left side 50.00 from wall
 Right side 50.00 from wall

Limit State: Serviceability Limit State

Calculated Bending Moments and Strut Forces are to be multiplied by a factor of 1.35 to obtain values for structural design. See summary for factored values.

Node no.	Y coord	Nett pressure kN/m2	Wall disp. m	Wall rotation rad.	Shear force kN/m	Bending moment kN.m/m	Strut forces kN/m	EI of wall kN.m2/m
1	49.75	0.00	0.005	-1.09E-03	0.0	-0.0		43355
2	49.40	24.28	0.006	-1.09E-03	4.2	0.6		43355
3	49.10	29.21	0.006	-1.10E-03	12.3	2.7		43355
4	48.80	26.10	0.007	-1.14E-03	20.6	7.7		43355
5	48.50	22.69	0.007	-1.22E-03	27.9	15.1		43355
6	48.20	19.88	0.007	-1.35E-03	34.3	24.4	109.8	43355
		19.88	0.007	-1.35E-03	-75.5	24.4		
7	47.90	24.03	0.008	-1.45E-03	-68.9	2.6		43355
8	47.50	29.47	0.008	-1.36E-03	-58.2	-23.2		43355
		29.84	0.008	-1.36E-03	-58.2	-23.2		
9	47.00	37.13	0.009	-9.59E-04	-41.5	-48.6		43355
10	46.50	44.19	0.009	-3.17E-04	-21.1	-64.8		43355
11	46.00	50.91	0.009	4.33E-04	2.6	-68.2		43355
12	45.50	57.17	0.009	1.16E-03	29.7	-61.2		43355
13	45.00	62.79	0.008	1.71E-03	59.7	-39.7		43355
		62.11	0.008	1.71E-03	59.7	-39.7		
14	44.53	68.38	0.007	1.93E-03	90.6	-4.8		43355
15	44.05	74.64	0.006	1.68E-03	124.6	45.7	202.7	43355
		74.64	0.006	1.68E-03	-78.0	45.7		
16	43.85	77.27	0.006	1.49E-03	-62.9	32.6		43355
17	43.42	55.22	0.005	1.24E-03	-34.7	16.2		43355
18	43.00	33.16	0.005	1.12E-03	-15.9	5.8		43355
19	42.50	18.26	0.004	1.09E-03	-3.1	0.8		43355
20	42.00	3.35	0.004	1.09E-03	2.3	0.1		43355
21	41.50	-8.55	0.003	1.10E-03	1.0	0.8		43355
22	41.13	-0.24	0.003	1.10E-03	-0.6	0.5		43355
23	40.75	3.51	0.002	1.10E-03	0.0	0.0		---
At elev. 48.20		Strut force =		109.8 kN/strut =		109.8 kN/m run		
At elev. 44.05		Strut force =		202.7 kN/strut =		202.7 kN/m run		

(continued)

Stage No.9 Change properties of soil type 3 to soil type 4
Ko pressures will not be reset

Node no.	Y coord	----- LEFT side -----					Total earth pressure kN/m2	Coeff. of subgrade reaction kN/m3
		----- Effective stresses -----						
		Water press. kN/m2	Vertic -al kN/m2	Active limit kN/m2	Passive limit kN/m2	Earth pressure kN/m2		
1	49.75	0.00	0.00	0.00	0.00	0.00	6768	
2	49.40	0.00	7.46	2.51	25.69	24.28	6768	
3	49.10	2.94	12.32	4.15	42.41	26.27	6768	
4	48.80	5.89	16.76	5.64	57.69	20.22	6768	
5	48.50	8.83	20.59	6.93	70.88	13.86	6768	
6	48.20	11.77	23.99	8.08	82.57	8.10	3123	
7	47.90	14.71	27.09	9.12	93.24	9.31	3123	
8	47.50	18.64	30.91	10.41	106.41	10.83	3123	
		18.64	30.91	9.97	112.74	11.20	9003	
9	47.00	23.54	35.87	11.57	130.80	13.59	9003	
10	46.50	28.45	40.58	13.09	148.00	15.74	9003	
11	46.00	33.35	45.14	14.56	164.60	17.56	9003	
12	45.50	38.26	49.58	15.99	180.81	18.91	9003	
13	45.00	43.16	53.95	17.40	196.74	19.62	9003	
		43.16	53.95	18.95	175.48	18.95	9243	
14	44.53	47.82	58.53	20.56	190.38	20.56	9682	
15	44.05	52.48	63.08	22.16	205.18	22.16	9653	
16	43.85	54.45	64.99	22.83	211.39	22.83	9830	
17	43.42	58.61	69.04	24.25	224.57	24.25	10204	
18	43.00	62.78	73.09	25.67	237.73	25.67	10579	
19	42.50	67.69	77.84	27.35	253.21	27.35	11020	
20	42.00	72.59	82.61	29.02	268.70	29.02	11461	
21	41.50	77.50	87.38	30.69	284.22	33.70	11901	
22	41.13	81.18	90.96	31.95	295.88	41.66	12232	
23	40.75	84.86	94.55	33.21	307.56	44.80	12562	

Node no.	Y coord	----- RIGHT side -----					Total earth pressure kN/m2	Coeff. of subgrade reaction kN/m3
		----- Effective stresses -----						
		Water press. kN/m2	Vertic -al kN/m2	Active limit kN/m2	Passive limit kN/m2	Earth pressure kN/m2		
1	49.75	0.00	0.00	0.00	0.00	0.00	0.0	
2	49.40	0.00	0.00	0.00	0.00	0.00	0.0	
3	49.10	0.00	0.00	0.00	0.00	0.00	0.0	
4	48.80	0.00	0.00	0.00	0.00	0.00	0.0	
5	48.50	0.00	0.00	0.00	0.00	0.00	0.0	
6	48.20	0.00	0.00	0.00	0.00	0.00	0.0	
7	47.90	0.00	0.00	0.00	0.00	0.00	0.0	
8	47.50	0.00	0.00	0.00	0.00	0.00	0.0	
9	47.00	0.00	0.00	0.00	0.00	0.00	0.0	
10	46.50	0.00	0.00	0.00	0.00	0.00	0.0	
11	46.00	0.00	0.00	0.00	0.00	0.00	0.0	
12	45.50	0.00	0.00	0.00	0.00	0.00	0.0	
13	45.00	0.00	0.00	0.00	0.00	0.00	0.0	
14	44.53	0.00	0.00	0.00	0.00	0.00	0.0	
15	44.05	0.00	0.00	0.00	0.00	0.00	0.0	
16	43.85	0.00	0.00	0.00	0.00	0.00	0.0	
		0.00	0.00	0.00	0.00	0.00	9830	
17	43.42	0.00	8.50	2.99	27.65	27.65	10204	
18	43.00	0.00	17.00	5.97	55.30	55.30	10579	
19	42.50	4.90	22.10	7.76	71.87	71.87	11020	
20	42.00	9.81	27.19	9.55	88.45	88.45	11461	
21	41.50	14.71	32.29	11.34	105.03	105.03	11901	

(continued)

Stage No.9 Change properties of soil type 3 to soil type 4
 Ko pressures will not be reset

Node no.	Y coord	----- RIGHT side -----					Total earth pressure	Coeff. of subgrade reaction
		Water press.	Vertic -al	Effective Active limit	Effective Passive limit	Earth pressure		
		kN/m2	kN/m2	kN/m2	kN/m2	kN/m2	kN/m2	kN/m3
22	41.13	18.39	36.11	12.69	117.47	104.68	123.07	12232
23	40.75	22.07	39.94	14.03	129.91	104.07	126.14	12562

Note: 101.61a Soil pressure at active limit
 119.75p Soil pressure at passive limit

Units: kN,m

Stage No.9 Change soil type 3 to soil type 4

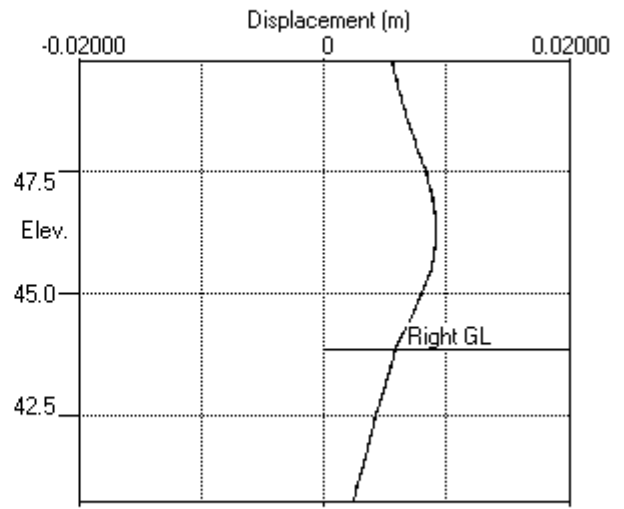
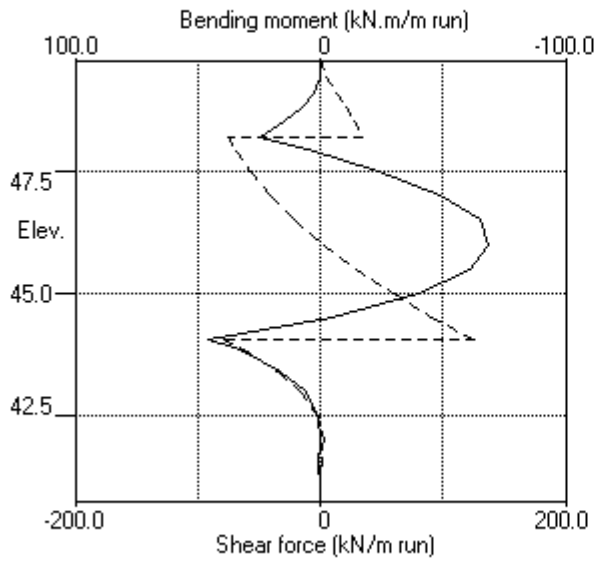

Stage No.9 Change soil type 3 to soil type 4

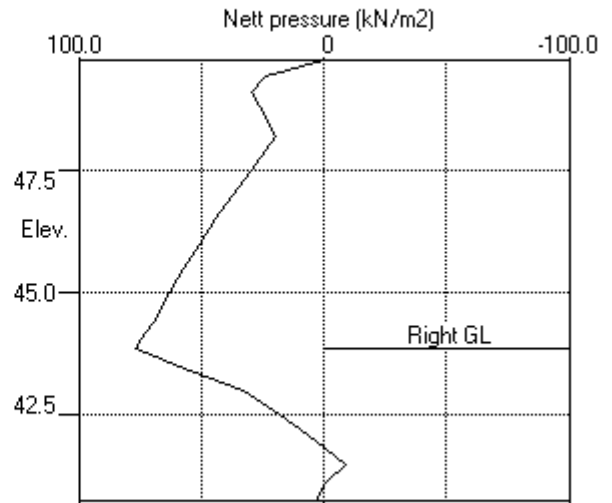
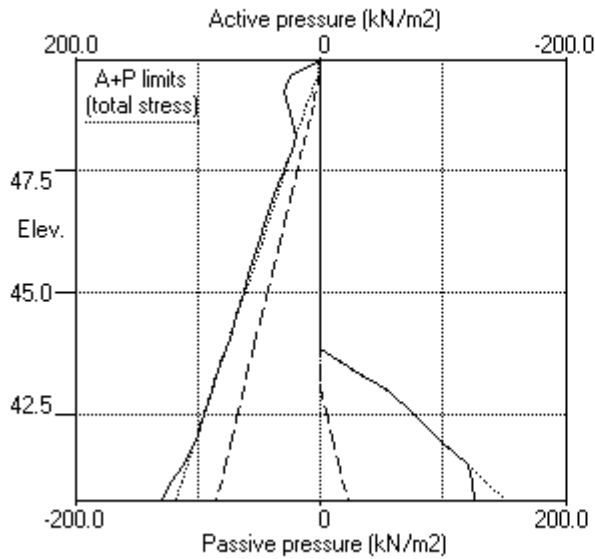

PILEDESIGNS LTD
 Program: WALLAP Version 6.06 Revision A51.B69.R54
 Licensed from GEOSOLVE
 Data filename/Run ID: Hampstead_Wall_2_450mm_rev_01_SLS
 Hampstead - 24-26 Redington Gardens
 Wall 5, Secant-SLS, 450 dia @ 650 - run 01

Sheet No.
 Job No. 21495
 Made by : DBS
 Date: 1-10-2018
 Checked :

 Units: kN,m

Summary of results

LIMIT STATE PARAMETERS

Limit State: Serviceability Limit State
 All loads and soil strengths are unfactored

STABILITY ANALYSIS of Fully Embedded Wall according to Strength Factor method
 Factor of safety on soil strength

Stage No.	G.L.		Strut Elev.	FoS for toe elev. = 40.75		Toe elev. for FoS = 1.500		Direction of failure
	Act.	Pass.		Factor of Safety	Moment at elev.	Toe elev.	Wall Penetration	
1	49.75	49.75	Cant.	Conditions not suitable for FoS calc.				
2	49.75	49.75	Cant.	Conditions not suitable for FoS calc.				
3	49.75	47.90	Cant.	2.273	41.81	42.61	5.29	L to R
4	49.75	47.90		No analysis at this stage				
5	49.75	47.90	48.20	6.504	n/a	46.91	0.99	L to R
6	49.75	43.85	48.20	2.150	n/a	42.77	1.08	L to R
7	49.75	43.85		No analysis at this stage				

All remaining stages have more than one strut - FoS calculation n/a

PILEDESIGNS LTD
 Program: WALLAP Version 6.06 Revision A51.B69.R54
 Licensed from GEOSOLVE
 Data filename/Run ID: Hampstead_Wall_2_450mm_rev_01_SLS
 Hampstead - 24-26 Redington Gardens
 Wall 5, Secant-SLS, 450 dia @ 650 - run 01

Sheet No.
 Job No. 21495
 Made by : DBS
 Date: 1-10-2018
 Checked :

Units: kN,m

Summary of results

BENDING MOMENT and DISPLACEMENT ANALYSIS of Fully Embedded Wall

Analysis options

Length of wall perpendicular to section = 50.00m
 Subgrade reaction model - Boussinesq Influence coefficients
 Soil deformations are elastic until the active or passive limit is reached
 Open Tension Crack analysis - No

Rigid boundaries: Left side 50.00 from wall
 Right side 50.00 from wall

Limit State: Serviceability Limit State

Calculated Bending Moments and Strut Forces have been multiplied by a factor of 1.35 to obtain values for structural design.

Bending moment, shear force and displacement envelopes

Node no.	Y coord	Displacement		Bending moment				Shear force			
		max.	min.	Calculated		Factored		Calculated		Factored	
		m	m	max.	min.	max.	min.	max.	min.	max.	min.
				kN.m/m		kN.m/m		kN/m		kN/m	
1	49.75	0.011	0.000	0	-0	0	-0	0	0	0	0
2	49.40	0.010	0.000	1	-0	1	-0	4	-1	6	-1
3	49.10	0.009	0.000	3	-0	4	-1	13	-2	17	-3
4	48.80	0.009	0.000	8	-1	11	-2	21	-2	29	-3
5	48.50	0.008	0.000	16	-2	21	-3	29	-2	39	-3
6	48.20	0.007	0.000	25	-2	34	-3	35	-81	48	-110
7	47.90	0.008	0.000	12	-3	16	-4	21	-75	28	-101
8	47.50	0.008	0.000	22	-26	29	-36	26	-64	35	-87
9	47.00	0.009	0.000	34	-55	46	-74	24	-48	32	-65
10	46.50	0.009	0.000	44	-74	59	-100	13	-29	18	-39
11	46.00	0.009	0.000	49	-82	66	-110	3	-7	4	-9
12	45.50	0.009	0.000	45	-79	60	-107	30	-11	40	-15
13	45.00	0.008	0.000	37	-63	50	-86	60	-16	81	-22
14	44.53	0.007	0.000	28	-38	38	-52	91	-18	122	-25
15	44.05	0.006	0.000	46	-7	62	-10	125	-78	168	-105
16	43.85	0.006	0.000	33	0	44	0	78	-63	106	-85
17	43.42	0.005	0.000	38	0	52	0	37	-35	51	-47
18	43.00	0.005	0.000	43	0	58	0	5	-16	7	-21
19	42.50	0.004	0.000	38	0	52	0	0	-21	0	-28
20	42.00	0.004	0.000	26	0	35	0	2	-27	3	-36
21	41.50	0.003	0.000	11	0	16	0	1	-24	1	-33
22	41.13	0.003	0.000	3	-0	5	-0	0	-15	0	-21
23	40.75	0.002	0.000	0	-0	0	-0	0	0	0	0

Summary of results (continued)

Calculated Bending Moments and Strut Forces have been multiplied by a factor of 1.35 to obtain values for structural design.

Maximum and minimum bending moment and shear force at each stage

Stage no.	Bending moment				Shear force							
	Calculated		Factored		Calculated		Factored					
min.	max. elev.	min. elev.	max. elev.	max. elev.	min. elev.	max. elev.	min. elev.	max. elev.				
	kN.m/m		kN.m/m		kN/m		kN/m					
1	2	43.42	-3	46.50	2	-5	4	45.00	-2	47.90	5	
-2	2	44.05	-3	47.90	6	-4	4	45.00	-2	48.80	6	
-3	3	49	46.00	-0	41.13	66	-0	26	47.50	-18	44.53	35
-25	4	No calculation at this stage										
5	40	46.00	-0	49.75	54	-0	21	47.50	-13	44.05	28	
-18	6	43	43.00	-82	46.00	58	-110	78	43.85	-81	48.20	106
-110	7	No calculation at this stage										
8	43	43.00	-76	46.00	58	-103	75	44.05	-79	48.20	101	
-106	9	46	44.05	-68	46.00	62	-92	125	44.05	-78	44.05	168
-105	10	No calculation at this stage										
11	28	44.05	-74	46.00	37	-100	118	44.05	-78	48.20	159	
-105												

Maximum and minimum displacement at each stage

Stage no.	Displacement				Stage description
	maximum elev.	minimum elev.	maximum elev.	minimum elev.	
	m		m		
1	0.001	47.90	0.000	49.75	Apply surcharge no.1 at elev. 49.75
2	0.002	49.75	0.000	49.75	Apply water pressure profile no.1
3	0.011	49.75	0.000	49.75	Excav. to elev. 47.90 on RIGHT side
4	No calculation at this stage				Install strut no.1 at elev. 48.20
5	0.011	49.75	0.000	49.75	Apply water pressure profile no.2
6	0.009	46.50	0.000	49.75	Excav. to elev. 43.85 on RIGHT side
7	No calculation at this stage				Install strut no.2 at elev. 44.05
8	0.009	46.00	0.000	49.75	Change EI of wall to 43355kN.m ² /m run
9	0.009	46.50	0.000	49.75	Change soil type 3 to soil type 4
10	No calculation at this stage				Apply surcharge no.2 at elev. 43.85
11	0.009	46.00	0.000	49.75	Apply water pressure profile no.3

Strut forces at each stage (horizontal components)

Stage no.	Strut no. 1			Strut no. 2		
	at elev. 48.20			at elev. 44.05		
	Calculated	Factored	Calculated	Factored	Calculated	Factored
	kN per m run	kN per strut	kN per strut	kN per m run	kN per strut	kN per strut
5	7	7	9	---	---	---
6	116	116	156	---	---	---
8	114	114	154	16	16	22
9	110	110	148	203	203	274
11	113	113	152	159	159	214

Units: kN,m

Bending moment, shear force, displacement envelopes

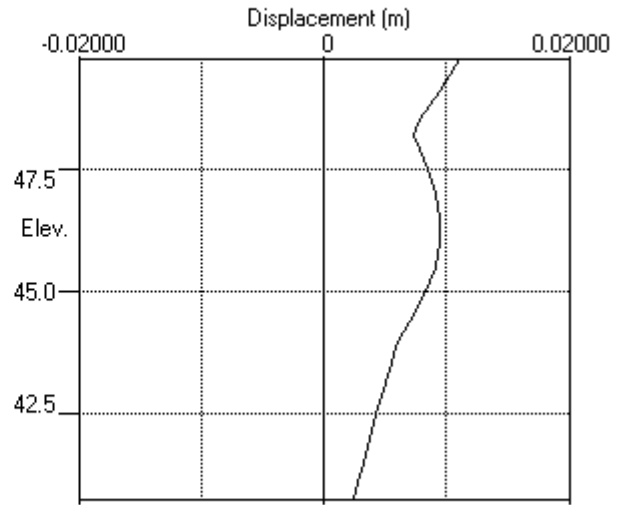
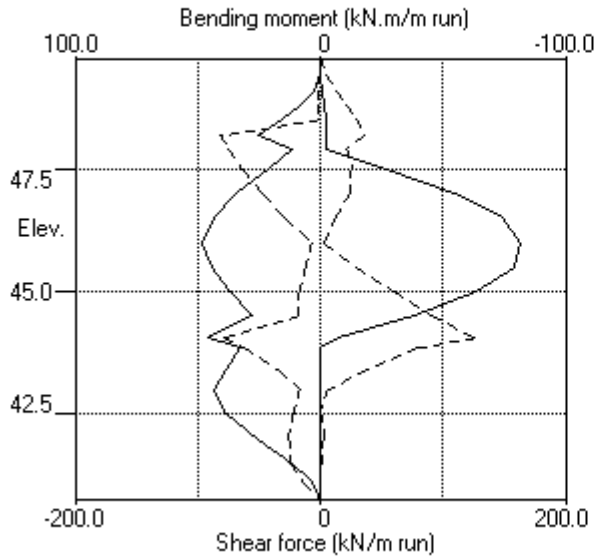



WALLAP

3-ULS1

PILEDESIGNS LTD
 Program: WALLAP Version 6.06 Revision A51.B69.R54
 Licensed from GEOSOLVE
 Data filename/Run ID: Hampstead_Wall_3_450mm_rev_01_ULS1
 Hampstead - 24-26 Redington Gardens
 Wall 3, Secant-ULS1, 450 dia @ 650 - run 01

Sheet No.
 Job No. 21495
 Made by : DBS
 Date: 1-10-2018
 Checked :

Units: kN,m

INPUT DATA

SOIL PROFILE

Stratum no.	Elevation of top of stratum	Soil types	
		Left side	Right side
1	49.75	1 Made Ground dr	1 Made Ground dr
2	47.50	2 Claygate Clay dr	2 Claygate Clay dr
3	45.00	3 London Clay und	3 London Clay und

SOIL PROPERTIES (Unfactored SLS soil strengths)

No. Description	Bulk density kN/m3	Young's Modulus Eh,kN/m2	At rest coeff. Ko	Consol state. NC/OC	Active limit Ka	Passive limit Kp	Cohesion kN/m2
(Datum elev.)		(dEh/dy)	(dKo/dy)	(Nu)	(Kac)	(Kpc)	(dc/dy)
1 Made Ground dr	18.00	10000	0.530	OC (0.250)	0.337 (0.000)	3.442 (0.000)	
2 Claygate Clay dr	19.00	30000	1.000	NC (0.200)	0.323 (1.330)	3.647 (5.195)	0.0d
3 London Cl.. (45.00)	20.00	40000 (4000)	1.000	OC (0.490)	1.000 (2.476)	1.000 (2.390)	50.00u (5.000)
4 London Cl.. (45.00)	20.00	30800 (3080)	1.000	OC (0.200)	0.351 (1.391)	3.253 (4.831)	0.0d

Additional soil parameters associated with Ka and Kp

No. Description	--- parameters for Ka ---			--- parameters for Kp ---		
	Soil friction angle	Wall adhesion coeff.	Back-fill angle	Soil friction angle	Wall adhesion coeff.	Back-fill angle
1 Made Ground dr	26.00	0.670	0.00	26.00	0.500	0.00
2 Claygate Clay dr	27.00	0.670	0.00	27.00	0.500	0.00
3 London Clay und	0.00	0.670	0.00	0.00	0.500	0.00
4 London Clay dr	25.00	0.670	0.00	25.00	0.500	0.00

GROUND WATER CONDITIONS

Density of water = 9.810 kN/m3

	Left side	Right side
Initial water table elevation	49.40	49.40

Automatic water pressure balancing at toe of wall : No

Water profile no.	Left side				Right side			
	Point no.	Elev. m	Piezo elev. m	Water press. kN/m2	Point no.	Elev. m	Piezo elev. m	Water press. kN/m2
1	1	49.40	49.40	0.0	1	47.50	47.50	0.0 MC+WC
2	1	49.40	49.40	0.0	1	43.00	43.00	0.0 MC+WC
3	1	49.40	49.40	0.0	1	43.85	43.85	0.0 MC+WC
					2	43.85	49.40	54.4

WALL PROPERTIES

Type of structure = Fully Embedded Wall
 Elevation of toe of wall = 40.75
 Maximum finite element length = 0.50 m
 Youngs modulus of wall E = 1.9600E+07 kN/m2
 Moment of inertia of wall I = 3.0968E-03 m4/m run
 E.I = 60696 kN.m2/m run
 Yield Moment of wall = Not defined

STRUTS and ANCHORS

Strut/ anchor no.	Elev.	Strut spacing m	X-section area of strut sq.m	Youngs modulus kN/m ²	Free length m	Inclin -ation (degs)	Pre- stress /strut kN	Tension allowed
1	48.20	1.00	0.300000	1.400E+07	5.00	0.00	0	No
2	44.05	1.00	0.300000	1.400E+07	5.00	0.00	0	No

SURCHARGE LOADS

Surch -arge no.	Elev.	Distance from wall	Length parallel to wall	Width perpend. to wall	Surcharge ----- Near edge	Surcharge ----- Far edge	Equiv. soil type	Partial factor/ Category
1	49.75	0.50(L)	10.00	2.75	13.00	=	N/A	1.10 Var
2	49.10	3.25(L)	10.00	0.50	90.00	=	N/A	1.00 P/U
3	43.85	-0.00(R)	10.00	10.00	55.00	=	N/A	1.00 P/F

Note: L = Left side, R = Right side

Limit State Categories P/U = Permanent Unfavourable
P/F = Permanent Favourable
Var = Variable (unfavourable)

CONSTRUCTION STAGES

Construction stage no.	Stage description
1	Apply surcharge no.1 at elevation 49.75
2	Apply surcharge no.2 at elevation 49.10
3	Apply water pressure profile no.1 (Mod. Conserv.)
4	Excavate to elevation 47.90 on RIGHT side
5	Install strut or anchor no.1 at elevation 48.20
6	Apply water pressure profile no.2 (Mod. Conserv.)
7	Excavate to elevation 43.41 on RIGHT side
8	Fill to elevation 43.85 on RIGHT side with soil type 1
9	Install strut or anchor no.2 at elevation 44.05
10	Change EI of wall to 43355 kN.m ² /m run Yield moment not defined Allow wall to relax with new modulus value
11	Change properties of soil type 3 to soil type 4 Ko pressures will not be reset
12	Apply surcharge no.3 at elevation 43.85 No analysis at this stage
13	Apply water pressure profile no.3 (Mod. Conserv.)

FACTORS OF SAFETY and ANALYSIS OPTIONS

Limit State options: ULS DA1 Combination 1
Water pressures : Moderately Conservative
Partial factor on C' = 1.000
Partial factor on Phi' = 1.000
Partial factor on Cu = 1.000
Partial factor on Soil Modulus = 1.000
Partial factor on Permanent Unfavourable loads = 1.000
Partial factor on Permanent Favourable loads = 1.000
Partial factor on Variable Unfavourable loads = 1.100
Design factor on calculated Bending Moments = 1.350

Parameters for undrained strata:

Minimum equivalent fluid density = 5.00 kN/m³
Maximum depth of water filled tension crack = 0.00 m

Bending moment and displacement calculation:

Method - Subgrade reaction model using Influence Coefficients
Open Tension Crack analysis? - No
Non-linear Modulus Parameter (L) = 9.000 m

Boundary conditions:

Length of wall (normal to plane of analysis) = 50.00 m

Width of excavation on Left side of wall = 50.00 m

Width of excavation on Right side of wall = 50.00 m

Distance to rigid boundary on Left side = 50.00 m

Distance to rigid boundary on Right side = 50.00 m

OUTPUT OPTIONS

Stage no.	Stage description	Displacement	Active, Passive pressures	Graph. output
1	Apply surcharge no.1 at elev. 49.75	No	No	No
2	Apply surcharge no.2 at elev. 49.10	Yes	Yes	Yes
3	Apply water pressure profile no.1	Yes	Yes	Yes
4	Excav. to elev. 47.90 on RIGHT side	Yes	Yes	Yes
5	Install strut no.1 at elev. 48.20	Yes	Yes	Yes
6	Apply water pressure profile no.2	Yes	Yes	Yes
7	Excav. to elev. 43.41 on RIGHT side	Yes	Yes	Yes
8	Fill to elev. 43.85 on RIGHT side	Yes	Yes	Yes
9	Install strut no.2 at elev. 44.05	Yes	Yes	Yes
10	Change EI of wall to 43355kN.m2/m run	No	No	No
11	Change soil type 3 to soil type 4	No	No	No
12	Apply surcharge no.3 at elev. 43.85	No	No	No
13	Apply water pressure profile no.3	No	No	No
*	Summary output	Yes	-	Yes

Program WALLAP - Copyright (C) 2017 by DL Borin, distributed by GEOSOLVE
 150 St. Alphonsus Road, London SW4 7BW, UK www.geosolve.co.uk

Units: kN,m

Stage No.13 Apply water pressure profile no.3 (Mod. Conserv.)

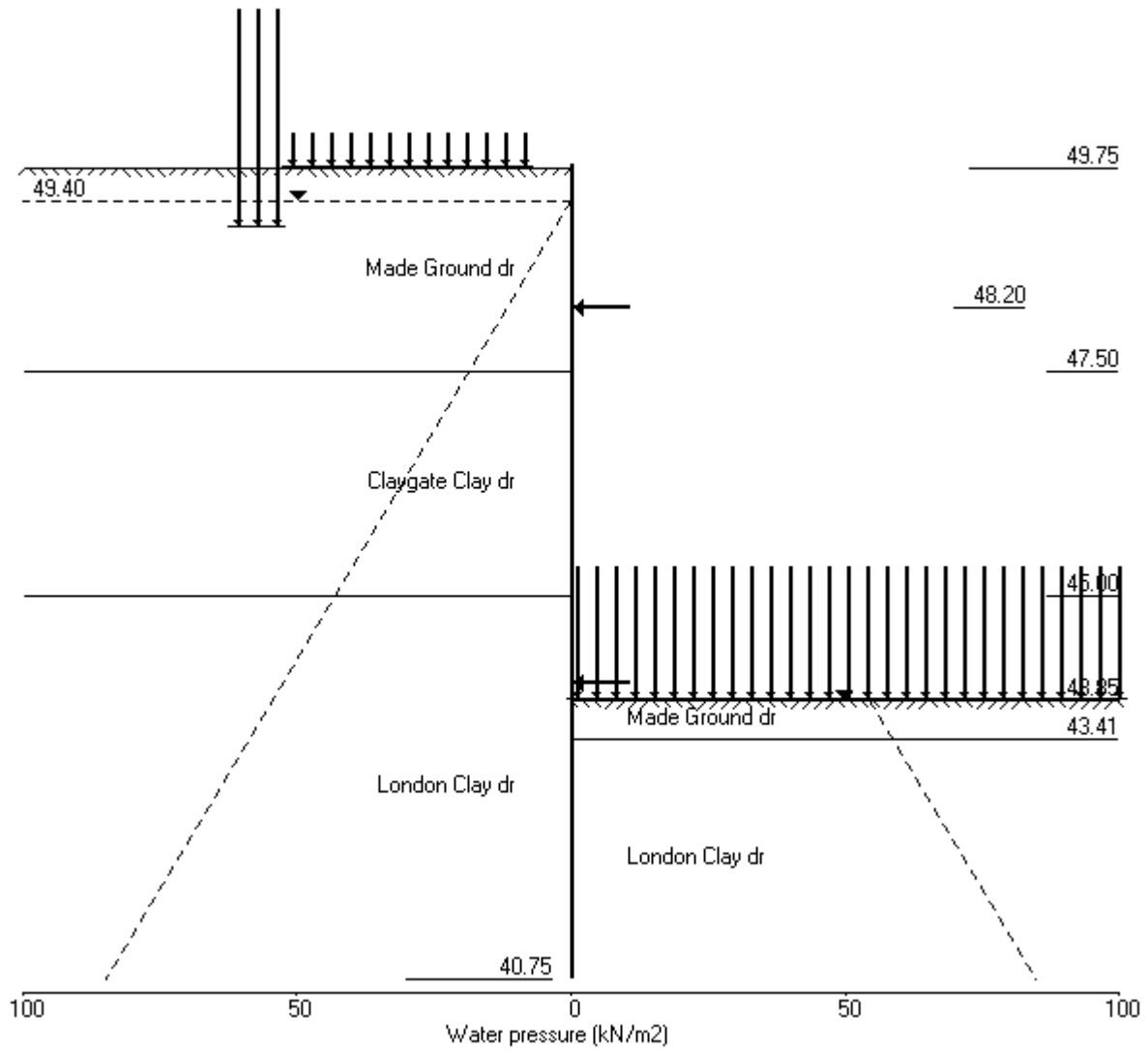

PILEDESIGNS LTD
 Program: WALLAP Version 6.06 Revision A51.B69.R54
 Licensed from GEOSOLVE
 Data filename/Run ID: Hampstead_Wall_3_450mm_rev_01_ULS1
 Hampstead - 24-26 Redington Gardens
 Wall 3, Secant-ULS1, 450 dia @ 650 - run 01

Sheet No.
 Job No. 21495
 Made by : DBS
 Date: 1-10-2018
 Checked :

Units: kN,m

Stage No. 4 Excavate to elevation 47.90 on RIGHT side

BENDING MOMENT and DISPLACEMENT ANALYSIS of Fully Embedded Wall

Analysis options

Length of wall perpendicular to section = 50.00m
 Subgrade reaction model - Boussinesq Influence coefficients
 Soil deformations are elastic until the active or passive limit is reached
 Open Tension Crack analysis - No

Rigid boundaries: Left side 50.00 from wall
 Right side 50.00 from wall

Limit State: ULS DA1 Combination 1

Calculated Bending Moments and Strut Forces are to be multiplied by a factor of 1.35 to obtain values for structural design. See summary for factored values.

Node no.	Y coord	Nett pressure kN/m2	Wall disp. m	Wall rotation rad.	Shear force kN/m	Bending moment kN.m/m	Strut forces kN/m	EI of wall kN.m2/m
1	49.75	0.00	0.012	2.68E-03	0.0	-0.0		60696
2	49.40	2.55	0.011	2.68E-03	0.4	0.1		60696
3	49.10	7.20	0.010	2.68E-03	1.9	0.5		60696
4	48.65	13.83	0.009	2.67E-03	6.6	2.3		60696
5	48.20	20.04	0.007	2.63E-03	14.3	6.9		60696
6	47.90	24.07	0.007	2.59E-03	20.9	12.1		60696
7	47.50	4.56	0.006	2.47E-03	26.6	21.9		60696
		2.64	0.006	2.47E-03	26.6	21.9		
8	47.00	-12.42	0.005	2.24E-03	24.2	34.8		60696
9	46.50	-27.56	0.003	1.91E-03	14.2	44.6		60696
10	46.00	-29.56	0.003	1.52E-03	-0.1	49.8		60696
11	45.50	-14.70	0.002	1.13E-03	-11.2	46.0		60696
12	45.00	-4.76	0.001	7.85E-04	-16.0	38.6		60696
		-10.33	0.001	7.85E-04	-16.0	38.6		
13	44.53	-0.19	0.001	5.18E-04	-18.5	29.8		60696
14	44.05	5.54	0.001	3.20E-04	-17.3	20.9		60696
15	43.85	6.90	0.001	2.56E-04	-16.0	17.6		60696
16	43.41	8.25	0.001	1.52E-04	-12.7	11.2		60696
17	43.00	8.05	0.001	9.23E-05	-9.4	6.7		60696
18	42.50	6.71	0.001	5.27E-05	-5.7	3.0		60696
19	42.00	4.81	0.001	3.66E-05	-2.8	0.9		60696
20	41.50	2.77	0.001	3.22E-05	-0.9	0.1		60696
21	41.13	1.18	0.001	3.19E-05	-0.1	-0.0		60696
22	40.75	-0.38	0.001	3.20E-05	0.0	0.0		---

Node no.	Y coord	LEFT side					Total earth pressure kN/m2	Coeff. of subgrade reaction kN/m3
		Water press. kN/m2	Vertic -al kN/m2	Effective Active limit kN/m2	Effective Passive limit kN/m2	Earth pressure kN/m2		
1	49.75	0.00	0.00	0.00	0.00	0.00	0.00	3617
2	49.40	0.00	7.57	2.55	26.07	2.55	2.55a	3617
3	49.10	2.94	12.64	4.25	43.49	4.25	7.20a	3617
4	48.65	7.36	19.23	6.47	66.18	6.47	13.83a	3617
5	48.20	11.77	24.57	8.27	84.58	8.27	20.04a	3617
6	47.90	14.71	27.77	9.35	95.60	9.35	24.07a	3617
7	47.50	18.64	31.80	10.71	109.47	10.71	29.35a	3617
		18.64	31.80	10.26	115.98	10.26	28.90a	10441
8	47.00	23.54	37.07	11.96	135.20	11.96	35.50a	10441
9	46.50	28.45	42.09	13.58	153.48	13.58	42.03a	10441
10	46.00	33.35	46.85	15.11	170.86	23.22	56.58	10441

(continued)

Stage No.4 Excavate to elevation 47.90 on RIGHT side

Node no.	Y coord	----- LEFT side -----					Total earth pressure kN/m2	Coeff. of subgrade reaction kN/m3
		Water press. kN/m2	Vertic -al kN/m2	Effective Active limit kN/m2	Effective Passive limit kN/m2	Earth pressure kN/m2		
11	45.50	38.26	51.39	16.58	187.40	34.39	72.65	10441
12	45.00	43.16	55.74	17.98	203.26	43.38	86.54	10441
		Total>	98.90	23.75m	218.41	74.14	74.14	20126
13	44.53	Total>	108.04	26.12m	233.23	87.98	87.98	21082
14	44.05	Total>	117.09	28.50m	247.96	99.86	99.86	22038
15	43.85	Total>	120.89	29.50m	254.15	104.40	104.40	22440
16	43.41	Total>	129.22	31.70m	267.74	113.64	113.64	23326
17	43.00	Total>	136.97	33.75m	280.39	121.60	121.60	24151
18	42.50	Total>	146.42	36.25m	295.81	130.81	130.81	25157
19	42.00	Total>	155.89	38.75m	311.26	139.78	139.78	26164
20	41.50	Total>	165.38	41.25m	326.72	148.70	148.70	27170
21	41.13	Total>	172.51	43.13m	338.33	155.36	155.36	27925
22	40.75	Total>	179.66	45.00m	349.97	162.05	162.05	28679

Node no.	Y coord	----- RIGHT side -----					Total earth pressure kN/m2	Coeff. of subgrade reaction kN/m3
		Water press. kN/m2	Vertic -al kN/m2	Effective Active limit kN/m2	Effective Passive limit kN/m2	Earth pressure kN/m2		
1	49.75	0.00	0.00	0.00	0.00	0.00	0.00	0.0
2	49.40	0.00	0.00	0.00	0.00	0.00	0.00	0.0
3	49.10	0.00	0.00	0.00	0.00	0.00	0.00	0.0
4	48.65	0.00	0.00	0.00	0.00	0.00	0.00	0.0
5	48.20	0.00	0.00	0.00	0.00	0.00	0.00	0.0
6	47.90	0.00	0.00	0.00	0.00	0.00	0.00	0.0
		0.00	0.00	0.00	0.00	0.00	0.00	4871
7	47.50	0.00	7.20	2.42	24.78	24.78	24.78p	4871
		0.00	7.20	2.32	26.26	26.26	26.26p	14087
8	47.00	4.90	11.80	3.80	43.01	43.01	47.92p	14087
9	46.50	9.81	16.39	5.29	59.77	59.77	69.58p	14087
10	46.00	14.71	20.99	6.77	76.53	71.42	86.13	14087
11	45.50	19.62	25.58	8.25	93.29	67.73	87.35	14087
12	45.00	24.52	30.18	9.73	110.05	66.78	91.30	14087
		Total>	54.70	14.50m	174.21	84.47	84.47	26631
13	44.53	Total>	64.20	16.88m	189.39	88.17	88.17	27896
14	44.05	Total>	73.71	19.25m	204.57	94.33	94.33	29161
15	43.85	Total>	77.71	20.25m	210.96	97.50	97.50	29693
16	43.41	Total>	86.51	22.45m	225.02	105.39	105.39	30865
17	43.00	Total>	94.71	24.50m	238.12	113.55	113.55	31957
18	42.50	Total>	104.72	27.00m	254.10	124.10	124.10	33289
19	42.00	Total>	114.72	29.50m	270.08	134.97	134.97	34620
20	41.50	Total>	124.73	32.00m	286.07	145.92	145.92	35952
21	41.13	Total>	132.23	33.88m	298.05	154.18	154.18	36950
22	40.75	Total>	139.74	35.75m	310.04	162.43	162.43	37949

Note: 42.03a Soil pressure at active limit
69.58p Soil pressure at passive limit

Units: kN,m

Stage No.4 Excav. to elev. 47.90 on RIGHT side

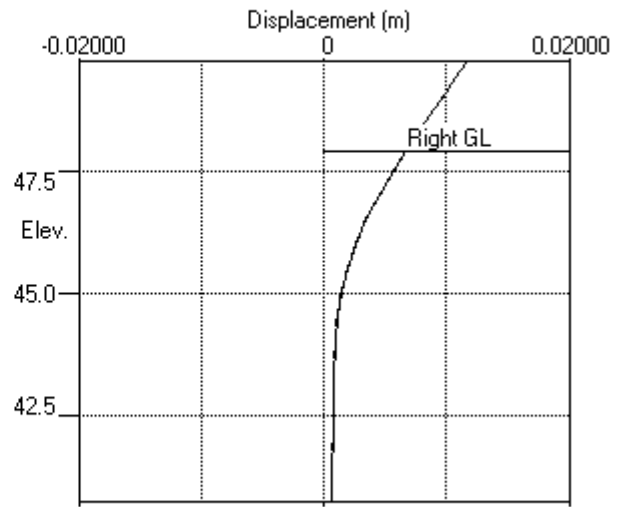
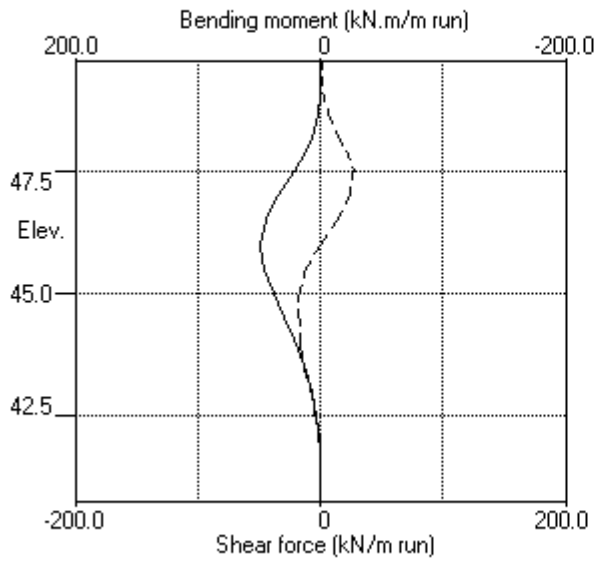

Stage No.4 Excav. to elev. 47.90 on RIGHT side

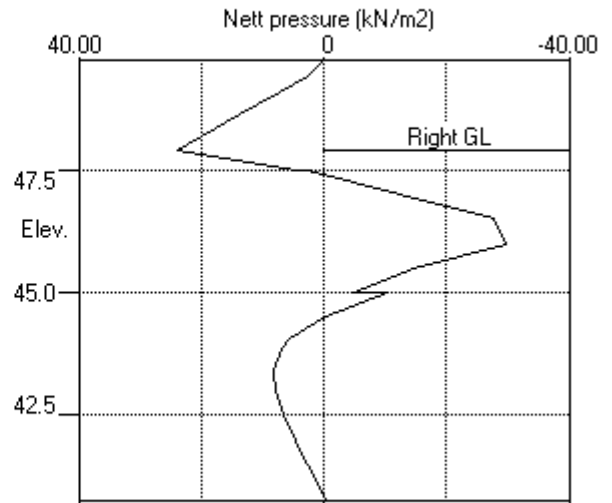
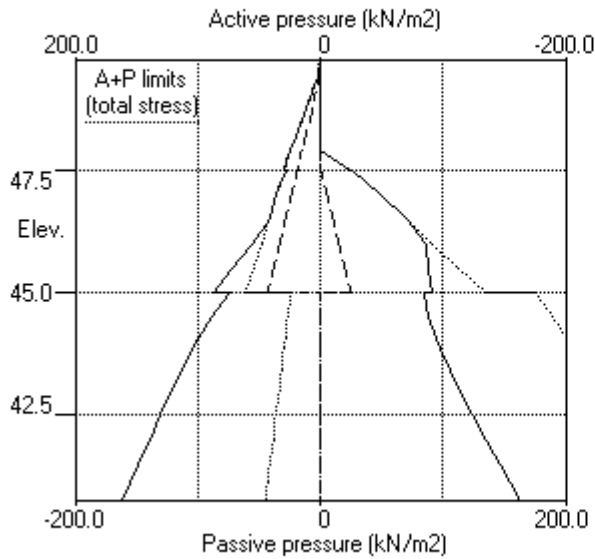

PILEDESIGNS LTD
 Program: WALLAP Version 6.06 Revision A51.B69.R54
 Licensed from GEOSOLVE
 Data filename/Run ID: Hampstead_Wall_3_450mm_rev_01_ULS1
 Hampstead - 24-26 Redington Gardens
 Wall 3, Secant-ULS1, 450 dia @ 650 - run 01

Sheet No.
 Job No. 21495
 Made by : DBS
 Date: 1-10-2018
 Checked :

Units: kN,m

Stage No. 7 Excavate to elevation 43.41 on RIGHT side

BENDING MOMENT and DISPLACEMENT ANALYSIS of Fully Embedded Wall

Analysis options

Length of wall perpendicular to section = 50.00m
 Subgrade reaction model - Boussinesq Influence coefficients
 Soil deformations are elastic until the active or passive limit is reached
 Open Tension Crack analysis - No

Rigid boundaries: Left side 50.00 from wall
 Right side 50.00 from wall

Limit State: ULS DA1 Combination 1

Calculated Bending Moments and Strut Forces are to be multiplied by a factor of 1.35 to obtain values for structural design. See summary for factored values.

Node no.	Y coord	Nett pressure kN/m2	Wall disp. m	Wall rotation rad.	Shear force kN/m	Bending moment kN.m/m	Strut forces kN/m	EI of wall kN.m2/m
1	49.75	0.00	0.005	-1.67E-03	0.0	-0.0		60696
2	49.40	26.07	0.006	-1.67E-03	4.6	0.6		60696
3	49.10	33.28	0.006	-1.68E-03	13.5	2.9		60696
4	48.65	26.47	0.007	-1.73E-03	26.9	12.5		60696
5	48.20	20.04	0.008	-1.88E-03	37.4	27.5	128.0	60696
		20.04	0.008	-1.88E-03	-90.7	27.5		
6	47.90	24.07	0.008	-1.95E-03	-84.0	1.3		60696
7	47.50	29.35	0.009	-1.86E-03	-73.4	-30.2		60696
		28.90	0.009	-1.86E-03	-73.4	-30.2		
8	47.00	35.50	0.010	-1.47E-03	-57.3	-63.0		60696
9	46.50	42.03	0.010	-8.60E-04	-37.9	-87.0		60696
10	46.00	48.47	0.011	-9.54E-05	-15.3	-98.7		60696
11	45.50	54.83	0.011	7.25E-04	10.6	-100.7		60696
12	45.00	61.14	0.010	1.50E-03	39.6	-88.7		60696
		23.75	0.010	1.50E-03	39.6	-88.7		
13	44.53	26.12	0.009	2.11E-03	51.4	-67.6		60696
14	44.05	28.50	0.008	2.54E-03	64.4	-40.4		60696
15	43.85	29.50	0.007	2.65E-03	70.2	-27.0		60696
16	43.41	31.70	0.006	2.72E-03	83.6	6.7		60696
		-106.80	0.006	2.72E-03	83.6	6.7		
17	43.00	-102.26	0.005	2.58E-03	40.8	34.1		60696
18	42.50	-75.03	0.004	2.25E-03	-3.5	46.8		60696
19	42.00	-29.18	0.003	1.91E-03	-29.6	35.6		60696
20	41.50	13.12	0.002	1.69E-03	-33.6	17.1		60696
21	41.13	44.28	0.001	1.62E-03	-22.8	5.5		60696
22	40.75	77.49	0.001	1.61E-03	0.0	-0.0		---

At elev. 48.20 Strut force = 128.0 kN/strut = 128.0 kN/m run

Node no.	Y coord	LEFT side						Total earth pressure kN/m2	Coeff. of subgrade reaction kN/m3
		Effective stresses							
		Water press. kN/m2	Vertic -al kN/m2	Active limit kN/m2	Passive limit kN/m2	Earth pressure kN/m2			
1	49.75	0.00	0.00	0.00	0.00	0.00	0.00	6817	
2	49.40	0.00	7.57	2.55	26.07	26.07	26.07p	6817	
3	49.10	2.94	12.64	4.25	43.49	30.34	33.28	6817	
4	48.65	7.36	19.23	6.47	66.18	19.12	26.47	6817	
5	48.20	11.77	24.57	8.27	84.58	8.27	20.04a	2351	
6	47.90	14.71	27.77	9.35	95.60	9.35	24.07a	2351	
7	47.50	18.64	31.80	10.71	109.47	10.71	29.35a	2351	
		18.64	31.80	10.26	115.98	10.26	28.90a	6753	

(continued)

Stage No.7 Excavate to elevation 43.41 on RIGHT side

Node no.	Y coord	Effective stresses					Total earth pressure	Coeff. of subgrade reaction
		Water press.	Vertic -al	Active limit	Passive limit	Earth pressure		
		kN/m2	kN/m2	kN/m2	kN/m2	kN/m2	kN/m2	kN/m3
8	47.00	23.54	37.07	11.96	135.20	11.96	35.50a	6753
9	46.50	28.45	42.09	13.58	153.48	13.58	42.03a	6753
10	46.00	33.35	46.85	15.11	170.86	15.11	48.47a	6753
11	45.50	38.26	51.39	16.58	187.40	16.58	54.83a	6753
12	45.00	43.16	55.74	17.98	203.26	17.98	61.14a	6753
		Total>	98.90	23.75m	218.41	23.75	23.75a	13621
13	44.53	Total>	108.04	26.12m	233.23	26.12	26.12a	14268
14	44.05	Total>	117.09	28.50m	247.96	28.50	28.50a	14915
15	43.85	Total>	120.89	29.50m	254.15	29.50	29.50a	15187
16	43.41	Total>	129.22	31.70m	267.74	31.70	31.70a	15786
17	43.00	Total>	136.97	33.75m	280.39	49.34	49.34	16345
18	42.50	Total>	146.42	36.25m	295.81	75.67	75.67	17026
19	42.00	Total>	155.89	38.75m	311.26	100.46	100.46	17707
20	41.50	Total>	165.38	41.25m	326.72	124.05	124.05	18388
21	41.13	Total>	172.51	43.13m	338.33	141.56	141.56	18899
22	40.75	Total>	179.66	45.00m	349.97	159.93	159.93	19409

Node no.	Y coord	Effective stresses					Total earth pressure	Coeff. of subgrade reaction
		Water press.	Vertic -al	Active limit	Passive limit	Earth pressure		
		kN/m2	kN/m2	kN/m2	kN/m2	kN/m2	kN/m2	kN/m3
1	49.75	0.00	0.00	0.00	0.00	0.00	0.00	0.0
2	49.40	0.00	0.00	0.00	0.00	0.00	0.00	0.0
3	49.10	0.00	0.00	0.00	0.00	0.00	0.00	0.0
4	48.65	0.00	0.00	0.00	0.00	0.00	0.00	0.0
5	48.20	0.00	0.00	0.00	0.00	0.00	0.00	0.0
6	47.90	0.00	0.00	0.00	0.00	0.00	0.00	0.0
7	47.50	0.00	0.00	0.00	0.00	0.00	0.00	0.0
8	47.00	0.00	0.00	0.00	0.00	0.00	0.00	0.0
9	46.50	0.00	0.00	0.00	0.00	0.00	0.00	0.0
10	46.00	0.00	0.00	0.00	0.00	0.00	0.00	0.0
11	45.50	0.00	0.00	0.00	0.00	0.00	0.00	0.0
12	45.00	0.00	0.00	0.00	0.00	0.00	0.00	0.0
13	44.53	0.00	0.00	0.00	0.00	0.00	0.00	0.0
14	44.05	0.00	0.00	0.00	0.00	0.00	0.00	0.0
15	43.85	0.00	0.00	0.00	0.00	0.00	0.00	0.0
16	43.41	0.00	0.00	0.00	0.00	0.00	0.00	0.0
		Total>	0.00	0.00	138.50	138.50	138.50p	32291
17	43.00	Total>	8.20	2.05m	151.60	151.60	151.60p	33433
18	42.50	Total>	18.20	4.55m	167.58	150.69	150.69	34826
19	42.00	Total>	28.20	7.05m	183.55	129.63	129.63	36219
20	41.50	Total>	38.20	9.55m	199.53	110.93	110.93	37612
21	41.13	Total>	45.70	11.42m	211.51	97.28	97.28	38657
22	40.75	Total>	53.21	13.30m	223.50	82.44	82.44	39702

Note: 31.70a Soil pressure at active limit
151.60p Soil pressure at passive limit

Units: kN,m

Stage No.7 Excav. to elev. 43.41 on RIGHT side

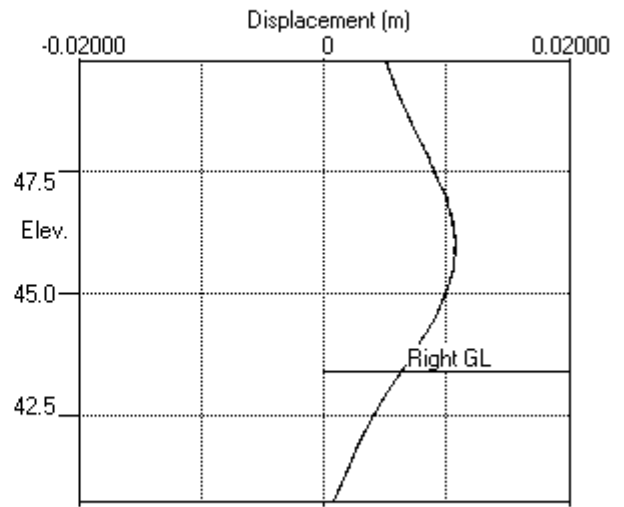
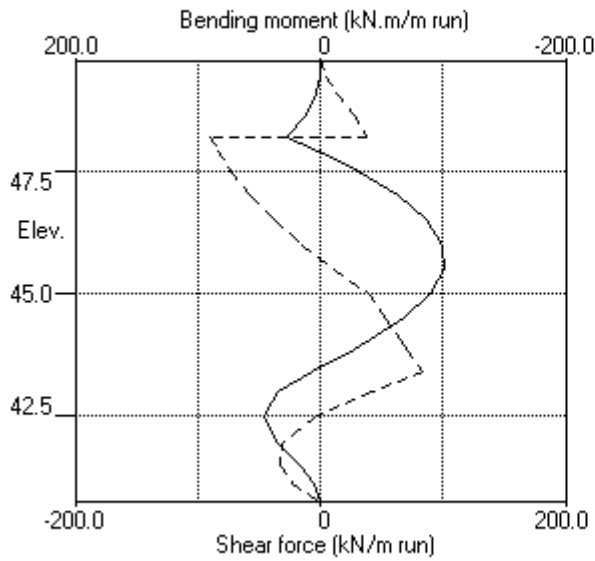

Stage No.7 Excav. to elev. 43.41 on RIGHT side

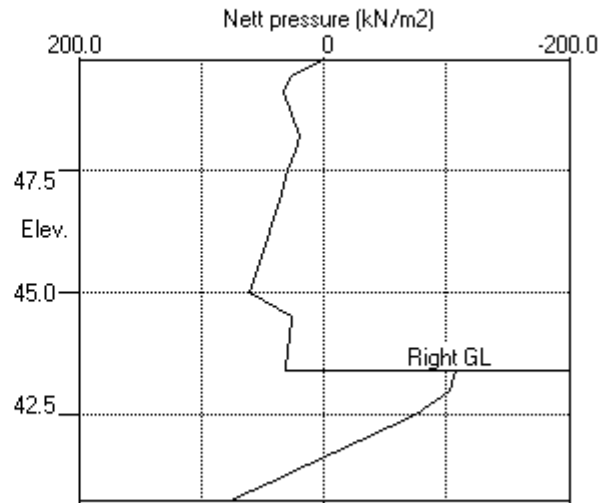
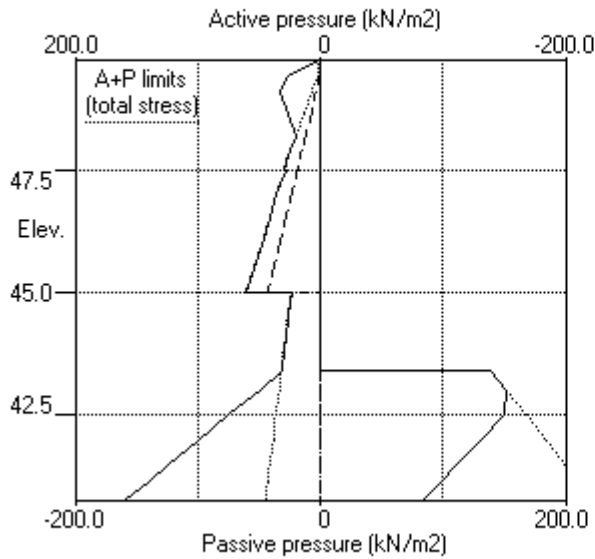

PILEDESIGNS LTD
 Program: WALLAP Version 6.06 Revision A51.B69.R54
 Licensed from GEOSOLVE
 Data filename/Run ID: Hampstead_Wall_3_450mm_rev_01_ULS1
 Hampstead - 24-26 Redington Gardens
 Wall 3, Secant-ULS1, 450 dia @ 650 - run 01

Sheet No.
 Job No. 21495
 Made by : DBS
 Date: 1-10-2018
 Checked :

Units: kN,m

Stage No. 8 Fill to elevation 43.85 on RIGHT side with soil type 1

BENDING MOMENT and DISPLACEMENT ANALYSIS of Fully Embedded Wall

Analysis options

Length of wall perpendicular to section = 50.00m
 Subgrade reaction model - Boussinesq Influence coefficients
 Soil deformations are elastic until the active or passive limit is reached
 Open Tension Crack analysis - No

Rigid boundaries: Left side 50.00 from wall
 Right side 50.00 from wall

Limit State: ULS DA1 Combination 1

Calculated Bending Moments and Strut Forces are to be multiplied by a factor of 1.35 to obtain values for structural design. See summary for factored values.

Node no.	Y coord	Nett pressure kN/m2	Wall disp. m	Wall rotation rad.	Shear force kN/m	Bending moment kN.m/m	Strut forces kN/m	EI of wall kN.m2/m
1	49.75	0.00	0.005	-1.66E-03	0.0	-0.0		60696
2	49.40	26.04	0.006	-1.66E-03	4.6	0.6		60696
3	49.10	33.25	0.006	-1.67E-03	13.4	2.9		60696
4	48.65	26.46	0.007	-1.73E-03	26.9	12.5		60696
5	48.20	20.04	0.008	-1.88E-03	37.3	27.5	128.4	60696
		20.04	0.008	-1.88E-03	-91.0	27.5		
6	47.90	24.07	0.008	-1.95E-03	-84.4	1.2		60696
7	47.50	29.35	0.009	-1.85E-03	-73.7	-30.5		60696
		28.92	0.009	-1.85E-03	-73.7	-30.5		
8	47.00	35.56	0.010	-1.46E-03	-57.6	-63.5		60696
9	46.50	42.13	0.010	-8.45E-04	-38.2	-87.7		60696
10	46.00	48.65	0.011	-7.48E-05	-15.5	-99.5		60696
11	45.50	55.11	0.010	7.53E-04	10.4	-101.6		60696
12	45.00	61.55	0.010	1.54E-03	39.6	-89.7		60696
		24.55	0.010	1.54E-03	39.6	-89.7		
13	44.53	27.27	0.009	2.15E-03	51.9	-68.4		60696
14	44.05	30.07	0.008	2.58E-03	65.5	-40.9		60696
15	43.85	31.27	0.007	2.69E-03	71.7	-27.2		60696
16	43.41	31.26	0.006	2.77E-03	85.4	7.3		60696
		-109.95	0.006	2.77E-03	85.4	7.3		
17	43.00	-104.55	0.005	2.62E-03	41.4	35.1		60696
18	42.50	-76.34	0.004	2.28E-03	-3.8	47.8		60696
19	42.00	-29.61	0.003	1.94E-03	-30.3	36.3		60696
20	41.50	13.48	0.002	1.71E-03	-34.3	17.5		60696
21	41.13	45.21	0.001	1.64E-03	-23.3	5.6		60696
22	40.75	79.00	0.001	1.63E-03	0.0	-0.0		---

At elev. 48.20 Strut force = 128.4 kN/strut = 128.4 kN/m run

Node no.	Y coord	LEFT side						Total earth pressure kN/m2	Coeff. of subgrade reaction kN/m3
		Effective stresses							
		Water press. kN/m2	Vertic -al kN/m2	Active limit kN/m2	Passive limit kN/m2	Earth pressure kN/m2			
1	49.75	0.00	0.00	0.00	0.00	0.00	0.00	6433	
2	49.40	0.00	7.57	2.55	26.07	26.04	26.04	6433	
3	49.10	2.94	12.64	4.25	43.49	30.31	33.25	6433	
4	48.65	7.36	19.23	6.47	66.18	19.10	26.46	6433	
5	48.20	11.77	24.57	8.27	84.58	8.27	20.04a	6433	
6	47.90	14.71	27.77	9.35	95.60	9.35	24.07a	2815	
7	47.50	18.64	31.80	10.71	109.47	10.72	29.35	2815	
		18.64	31.80	10.26	115.98	10.29	28.92	8105	

(continued)

Stage No.8 Fill to elevation 43.85 on RIGHT side with soil type 1

Node no.	Y coord	LEFT side					Total earth pressure	Coeff. of subgrade reaction
		Water press. kN/m2	Vertic -al kN/m2	Effective Active limit kN/m2	Effective Passive limit kN/m2	Earth pressure kN/m2		
8	47.00	23.54	37.07	11.96	135.20	12.02	35.56	8105
9	46.50	28.45	42.09	13.58	153.48	13.68	42.13	8105
10	46.00	33.35	46.85	15.11	170.86	15.29	48.65	8105
11	45.50	38.26	51.39	16.58	187.40	16.85	55.11	8105
12	45.00	43.16	55.74	17.98	203.26	18.38	61.55	8105
		Total>	98.90	23.75m	218.41	24.55	24.55	15984
13	44.53	Total>	108.04	26.12m	233.23	27.27	27.27	16743
14	44.05	Total>	117.09	28.50m	247.96	30.07	30.07	17502
15	43.85	Total>	120.89	29.50m	254.15	31.27	31.27	17822
16	43.41	Total>	129.22	31.70m	267.74	33.93	33.93	18525
17	43.00	Total>	136.97	33.75m	280.39	52.00	52.00	19181
18	42.50	Total>	146.42	36.25m	295.81	78.82	78.82	19980
19	42.00	Total>	155.89	38.75m	311.26	104.05	104.05	20779
20	41.50	Total>	165.38	41.25m	326.72	128.04	128.04	21578
21	41.13	Total>	172.51	43.13m	338.33	145.83	145.83	22178
22	40.75	Total>	179.66	45.00m	349.97	164.49	164.49	22777

Node no.	Y coord	RIGHT side					Total earth pressure	Coeff. of subgrade reaction
		Water press. kN/m2	Vertic -al kN/m2	Effective Active limit kN/m2	Effective Passive limit kN/m2	Earth pressure kN/m2		
1	49.75	0.00	0.00	0.00	0.00	0.00	0.00	0.0
2	49.40	0.00	0.00	0.00	0.00	0.00	0.00	0.0
3	49.10	0.00	0.00	0.00	0.00	0.00	0.00	0.0
4	48.65	0.00	0.00	0.00	0.00	0.00	0.00	0.0
5	48.20	0.00	0.00	0.00	0.00	0.00	0.00	0.0
6	47.90	0.00	0.00	0.00	0.00	0.00	0.00	0.0
7	47.50	0.00	0.00	0.00	0.00	0.00	0.00	0.0
8	47.00	0.00	0.00	0.00	0.00	0.00	0.00	0.0
9	46.50	0.00	0.00	0.00	0.00	0.00	0.00	0.0
10	46.00	0.00	0.00	0.00	0.00	0.00	0.00	0.0
11	45.50	0.00	0.00	0.00	0.00	0.00	0.00	0.0
12	45.00	0.00	0.00	0.00	0.00	0.00	0.00	0.0
13	44.53	0.00	0.00	0.00	0.00	0.00	0.00	0.0
14	44.05	0.00	0.00	0.00	0.00	0.00	0.00	0.0
15	43.85	0.00	0.00	0.00	0.00	0.00	0.00	0.0
		0.00	0.00	0.00	0.00	0.00	0.00	2815
16	43.41	0.00	7.92	2.67	27.26	2.67	2.67a	2815
		Total>	7.92	2.20m	146.42	143.88	143.88	18525
17	43.00	Total>	16.12	4.25m	159.52	156.55	156.55	19181
18	42.50	Total>	26.12	6.75m	175.50	155.15	155.15	19980
19	42.00	Total>	36.12	9.25m	191.48	133.66	133.66	20779
20	41.50	Total>	46.12	11.75m	207.45	114.56	114.56	21578
21	41.13	Total>	53.63	13.62m	219.44	100.62	100.62	22178
22	40.75	Total>	61.13	15.50m	231.42	85.49	85.49	22777

Note: 2.67a Soil pressure at active limit
 123.45p Soil pressure at passive limit

Units: kN,m

Stage No.8 Fill to elev. 43.85 on RIGHT side

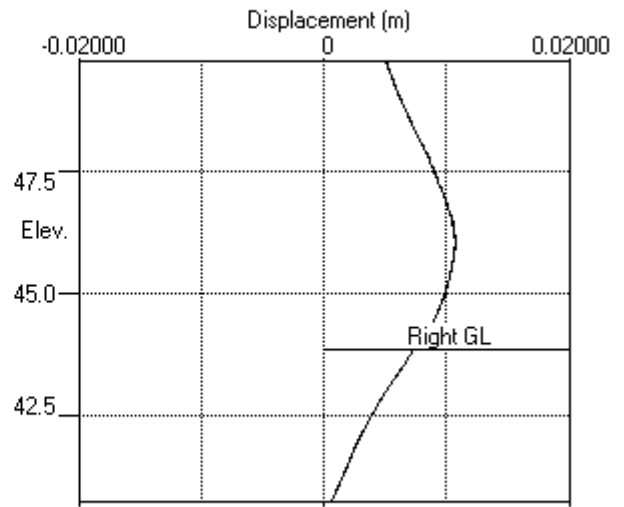
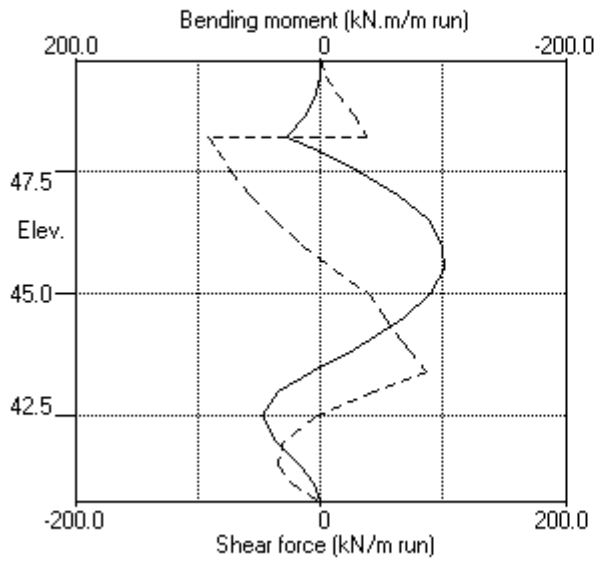

Stage No.8 Fill to elev. 43.85 on RIGHT side

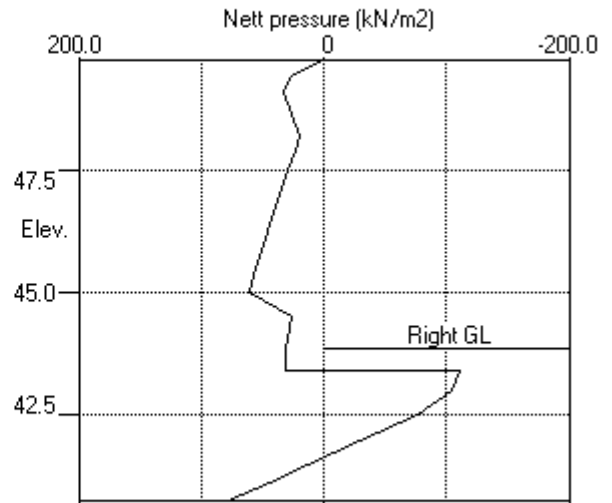
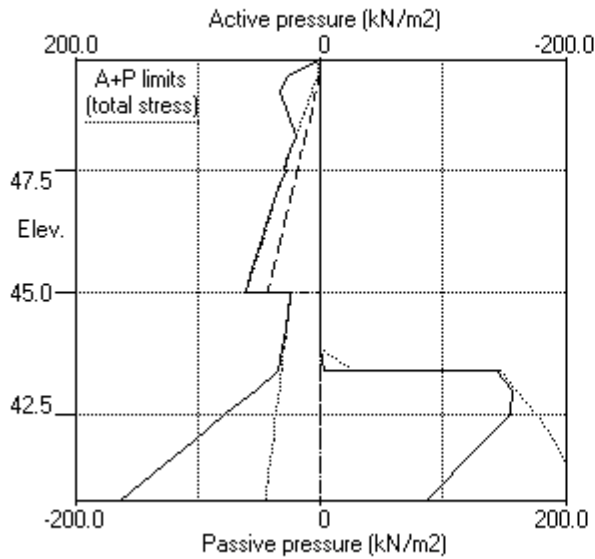

Units: kN,m

Stage No. 10 Change EI of wall to 43355 kN.m2/m run
 Yield moment not defined
 Allow wall to relax with new modulus value

BENDING MOMENT and DISPLACEMENT ANALYSIS of Fully Embedded Wall

Analysis options

Length of wall perpendicular to section = 50.00m
 Subgrade reaction model - Boussinesq Influence coefficients
 Soil deformations are elastic until the active or passive limit is reached
 Open Tension Crack analysis - No

Rigid boundaries: Left side 50.00 from wall
 Right side 50.00 from wall

Limit State: ULS DA1 Combination 1

Calculated Bending Moments and Strut Forces are to be multiplied by a factor of 1.35 to obtain values for structural design. See summary for factored values.

Node no.	Y coord	Nett pressure kN/m2	Wall disp. m	Wall rotation rad.	Shear force kN/m	Bending moment kN.m/m	Strut forces kN/m	EI of wall kN.m2/m
1	49.75	0.00	0.005	-1.93E-03	0.0	-0.0		43355
2	49.40	26.07	0.005	-1.94E-03	4.6	0.6		43355
3	49.10	35.07	0.006	-1.95E-03	13.7	2.9		43355
4	48.65	27.44	0.007	-2.03E-03	27.8	12.8		43355
5	48.20	20.07	0.008	-2.24E-03	38.5	28.1	124.5	43355
		20.07	0.008	-2.24E-03	-86.0	28.1		
6	47.90	24.07	0.008	-2.35E-03	-79.4	3.0		43355
7	47.50	29.35	0.009	-2.25E-03	-68.7	-27.1		43355
		28.90	0.009	-2.25E-03	-68.7	-27.1		
8	47.00	35.50	0.010	-1.77E-03	-52.6	-58.2		43355
9	46.50	42.03	0.011	-9.98E-04	-33.2	-80.4		43355
10	46.00	48.47	0.011	-4.12E-05	-10.6	-90.3		43355
11	45.50	54.83	0.011	9.68E-04	15.2	-90.5		43355
12	45.00	61.14	0.010	1.89E-03	44.2	-76.8		43355
		23.75	0.010	1.89E-03	44.2	-76.8		
13	44.53	26.12	0.009	2.56E-03	56.1	-53.9		43355
14	44.05	29.59	0.008	2.94E-03	69.3	-24.9	21.4	43355
		29.59	0.008	2.94E-03	47.9	-24.9		
15	43.85	32.25	0.007	3.02E-03	54.0	-14.0		43355
16	43.41	35.13	0.006	2.98E-03	68.9	14.5		43355
		-102.22	0.006	2.98E-03	68.9	14.5		
17	43.00	-93.31	0.005	2.72E-03	28.8	37.6		43355
18	42.50	-63.98	0.004	2.24E-03	-10.5	46.5		43355
19	42.00	-19.58	0.003	1.78E-03	-31.4	33.6		43355
20	41.50	18.76	0.002	1.51E-03	-31.6	15.3		43355
21	41.13	46.12	0.001	1.43E-03	-19.5	4.4		43355
22	40.75	57.70	0.001	1.41E-03	0.0	-0.0		---
At elev. 48.20		Strut force =		124.5 kN/strut =		124.5 kN/m run		
At elev. 44.05		Strut force =		21.4 kN/strut =		21.4 kN/m run		

Node no.	Y coord	LEFT side					Total earth pressure	Coeff. of earth reaction
		Water press. kN/m2	Vertic -al kN/m2	Effective Active limit kN/m2	Passive limit kN/m2	Earth pressure kN/m2	kN/m2	kN/m3
1	49.75	0.00	0.00	0.00	0.00	0.00	0.00	6423
2	49.40	0.00	7.57	2.55	26.07	26.07	26.07p	6423
3	49.10	2.94	12.64	4.25	43.49	32.13	35.07	6423
4	48.65	7.36	19.23	6.47	66.18	20.09	27.44	6423

(continued)

Stage No.10 Change EI of wall to 43355 kN.m2/m run
Yield moment not defined
Allow wall to relax with new modulus value

Node no.	Y coord	LEFT side					Total earth pressure	Coeff. of subgrade reaction
		Water press.	Vertic -al	Active limit	Passive limit	Earth pressure		
		kN/m2	kN/m2	kN/m2	kN/m2	kN/m2	kN/m2	kN/m3
5	48.20	11.77	24.57	8.27	84.58	8.30	20.07	6423
6	47.90	14.71	27.77	9.35	95.60	9.35	24.07a	3049
7	47.50	18.64	31.80	10.71	109.47	10.71	29.35a	3049
		18.64	31.80	10.26	115.98	10.26	28.90a	8786
8	47.00	23.54	37.07	11.96	135.20	11.96	35.50a	8786
9	46.50	28.45	42.09	13.58	153.48	13.58	42.03a	8786
10	46.00	33.35	46.85	15.11	170.86	15.11	48.47a	8786
11	45.50	38.26	51.39	16.58	187.40	16.58	54.83a	8786
12	45.00	43.16	55.74	17.98	203.26	17.98	61.14a	8786
		Total>	98.90	23.75m	218.41	23.75	23.75a	17187
13	44.53	Total>	108.04	26.12m	233.23	26.12	26.12a	18003
14	44.05	Total>	117.09	28.50m	247.96	29.59	29.59	18819
15	43.85	Total>	120.89	29.50m	254.15	32.25	32.25	22986
16	43.41	Total>	129.22	31.70m	267.74	37.80	37.80	23893
17	43.00	Total>	136.97	33.75m	280.39	57.62	57.62	24738
18	42.50	Total>	146.42	36.25m	295.81	84.99	84.99	25769
19	42.00	Total>	155.89	38.75m	311.26	109.06	109.06	26800
20	41.50	Total>	165.38	41.25m	326.72	130.68	130.68	27831
21	41.13	Total>	172.51	43.13m	338.33	146.28	146.28	29815
22	40.75	Total>	179.66	45.00m	349.97	153.84	153.84	161890

Node no.	Y coord	RIGHT side					Total earth pressure	Coeff. of subgrade reaction
		Water press.	Vertic -al	Active limit	Passive limit	Earth pressure		
		kN/m2	kN/m2	kN/m2	kN/m2	kN/m2	kN/m2	kN/m3
1	49.75	0.00	0.00	0.00	0.00	0.00	0.00	0.0
2	49.40	0.00	0.00	0.00	0.00	0.00	0.00	0.0
3	49.10	0.00	0.00	0.00	0.00	0.00	0.00	0.0
4	48.65	0.00	0.00	0.00	0.00	0.00	0.00	0.0
5	48.20	0.00	0.00	0.00	0.00	0.00	0.00	0.0
6	47.90	0.00	0.00	0.00	0.00	0.00	0.00	0.0
7	47.50	0.00	0.00	0.00	0.00	0.00	0.00	0.0
8	47.00	0.00	0.00	0.00	0.00	0.00	0.00	0.0
9	46.50	0.00	0.00	0.00	0.00	0.00	0.00	0.0
10	46.00	0.00	0.00	0.00	0.00	0.00	0.00	0.0
11	45.50	0.00	0.00	0.00	0.00	0.00	0.00	0.0
12	45.00	0.00	0.00	0.00	0.00	0.00	0.00	0.0
13	44.53	0.00	0.00	0.00	0.00	0.00	0.00	0.0
14	44.05	0.00	0.00	0.00	0.00	0.00	0.00	0.0
15	43.85	0.00	0.00	0.00	0.00	0.00	0.00	0.0
		0.00	0.00	0.00	0.00	0.00	0.00	3712
16	43.41	0.00	7.92	2.67	27.26	2.67	2.67a	3712
		Total>	7.92	2.20m	146.42	140.01	140.01	23893
17	43.00	Total>	16.12	4.25m	159.52	150.93	150.93	24738
18	42.50	Total>	26.12	6.75m	175.50	148.97	148.97	25769
19	42.00	Total>	36.12	9.25m	191.48	128.64	128.64	26800
20	41.50	Total>	46.12	11.75m	207.45	111.92	111.92	27831
21	41.13	Total>	53.63	13.62m	219.44	100.16	100.16	29815
22	40.75	Total>	61.13	15.50m	231.42	96.14	96.14	161890

Run ID. Hampstead_Wall_3_450mm_rev_01_ULS1
Hampstead - 24-26 Redington Gardens
Wall 3, Secant-ULS1, 450 dia @ 650 - run 01

| Sheet No.
| Date: 1-10-2018
| Checked :

(continued)

Stage No.10 Change EI of wall to 43355 kN.m²/m run
Yield moment not defined
Allow wall to relax with new modulus value
Note: 2.67a Soil pressure at active limit
26.07p Soil pressure at passive limit

Units: kN,m

Stage No.10 Change EI of wall to 43355kN.m²/m run

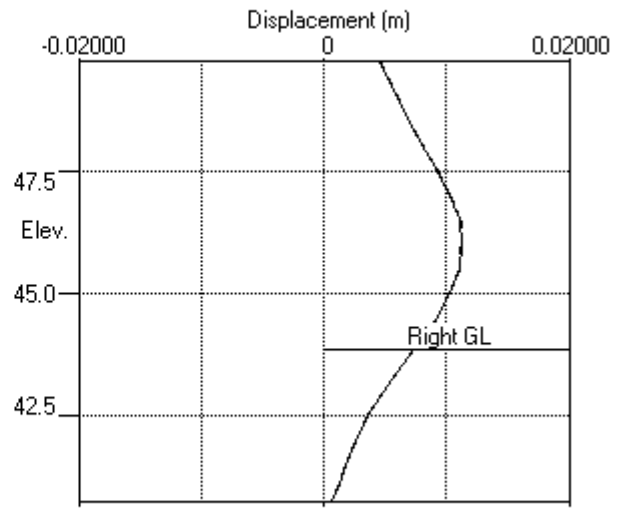
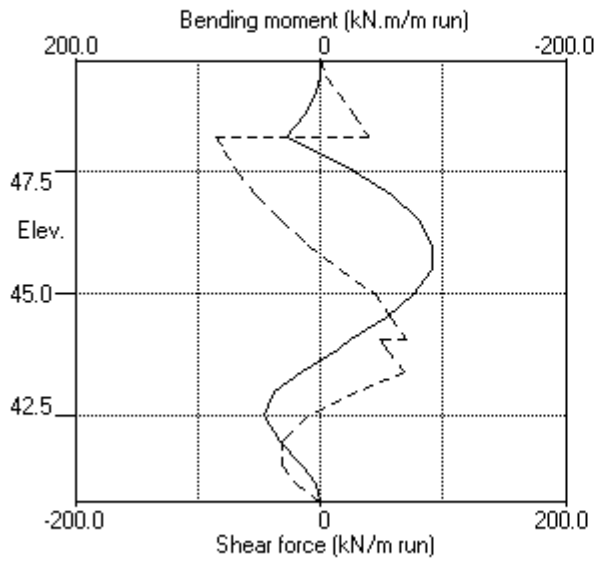

Stage No.10 Change EI of wall to 43355kN.m²/m run

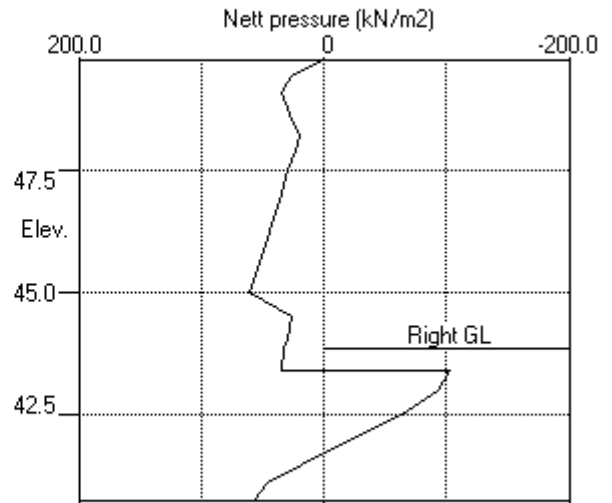
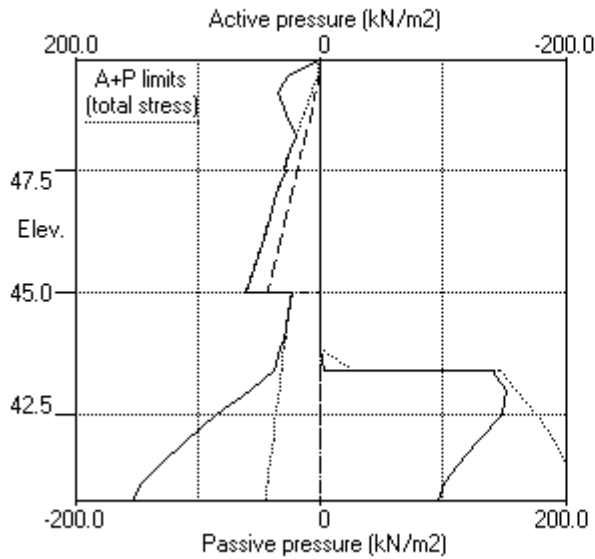

PILEDESIGNS LTD
 Program: WALLAP Version 6.06 Revision A51.B69.R54
 Licensed from GEOSOLVE
 Data filename/Run ID: Hampstead_Wall_3_450mm_rev_01_ULS1
 Hampstead - 24-26 Redington Gardens
 Wall 3, Secant-ULS1, 450 dia @ 650 - run 01

Sheet No.
 Job No. 21495
 Made by : DBS
 Date: 1-10-2018
 Checked :

Units: kN,m

Stage No. 11 Change properties of soil type 3 to soil type 4
 Ko pressures will not be reset

BENDING MOMENT and DISPLACEMENT ANALYSIS of Fully Embedded Wall

Analysis options

Length of wall perpendicular to section = 50.00m
 Subgrade reaction model - Boussinesq Influence coefficients
 Soil deformations are elastic until the active or passive limit is reached
 Open Tension Crack analysis - No

Rigid boundaries: Left side 50.00 from wall
 Right side 50.00 from wall

Limit State: ULS DA1 Combination 1

Calculated Bending Moments and Strut Forces are to be multiplied by a factor of 1.35 to obtain values for structural design. See summary for factored values.

Node no.	Y coord	Nett pressure kN/m2	Wall disp. m	Wall rotation rad.	Shear force kN/m	Bending moment kN.m/m	Strut forces kN/m	EI of wall kN.m2/m
1	49.75	0.00	0.005	-1.64E-03	0.0	-0.0		43355
2	49.40	23.73	0.006	-1.65E-03	4.2	0.6		43355
3	49.10	33.31	0.006	-1.66E-03	12.7	2.7		43355
4	48.65	26.58	0.007	-1.73E-03	26.2	11.9		43355
5	48.20	20.10	0.008	-1.93E-03	36.7	26.5	118.0	43355
		20.10	0.008	-1.93E-03	-81.3	26.5		
6	47.90	24.38	0.008	-2.04E-03	-74.7	2.7		43355
7	47.50	30.04	0.009	-1.94E-03	-63.8	-25.5		43355
		30.90	0.009	-1.94E-03	-63.8	-25.5		
8	47.00	38.81	0.010	-1.50E-03	-46.3	-53.8		43355
9	46.50	46.40	0.011	-7.94E-04	-25.0	-72.5		43355
10	46.00	53.50	0.011	4.46E-05	-0.1	-77.8		43355
11	45.50	59.88	0.010	8.75E-04	28.3	-72.0		43355
12	45.00	65.25	0.010	1.54E-03	59.6	-51.1		43355
		62.74	0.010	1.54E-03	59.6	-51.1		
13	44.53	68.98	0.009	1.87E-03	90.8	-16.4		43355
14	44.05	75.18	0.008	1.72E-03	125.1	34.0	207.8	43355
		75.18	0.008	1.72E-03	-82.7	34.0		
15	43.85	77.79	0.008	1.58E-03	-67.4	19.8		43355
16	43.41	77.27	0.007	1.45E-03	-33.3	-0.7		43355
		57.75	0.007	1.45E-03	-33.3	-0.7		
17	43.00	36.41	0.007	1.48E-03	-14.0	-6.9		43355
18	42.50	21.43	0.006	1.54E-03	0.5	-5.1		43355
19	42.00	6.46	0.005	1.60E-03	7.5	-4.2		43355
20	41.50	-8.52	0.004	1.65E-03	7.0	-2.1		43355
21	41.13	-13.66	0.004	1.66E-03	2.8	0.3		43355
22	40.75	-1.29	0.003	1.66E-03	0.0	0.0		---

At elev. 48.20 Strut force = 118.0 kN/strut = 118.0 kN/m run

At elev. 44.05 Strut force = 207.8 kN/strut = 207.8 kN/m run

Node no.	Y coord	LEFT side					Total earth pressure kN/m2	Coeff. of subgrade reaction kN/m3
		Water press. kN/m2	Effective stresses			Earth pressure kN/m2		
			Vertic -al kN/m2	Active limit kN/m2	Passive limit kN/m2			
1	49.75	0.00	0.00	0.00	0.00	0.00	6763	
2	49.40	0.00	7.57	2.55	26.07	23.73	6763	
3	49.10	2.94	12.64	4.25	43.49	30.37	6763	
4	48.65	7.36	19.23	6.47	66.18	19.22	6763	
5	48.20	11.77	24.57	8.27	84.58	8.33	3060	

(continued)

Stage No.11 Change properties of soil type 3 to soil type 4
Ko pressures will not be reset

Node no.	Y coord	----- LEFT side -----						Total earth pressure kN/m2	Coeff. of subgrade reaction kN/m3
		Water press. kN/m2	Vertic -al kN/m2	Effective stresses		Earth pressure kN/m2			
				Active limit kN/m2	Passive limit kN/m2				
6	47.90	14.71	27.77	9.35	95.60	9.66	24.38	3060	
7	47.50	18.64	31.80	10.71	109.47	11.40	30.04	3060	
		18.64	31.80	10.26	115.98	12.26	30.90	8821	
8	47.00	23.54	37.07	11.96	135.20	15.27	38.81	8821	
9	46.50	28.45	42.09	13.58	153.48	17.95	46.40	8821	
10	46.00	33.35	46.85	15.11	170.86	20.15	53.50	8821	
11	45.50	38.26	51.39	16.58	187.40	21.62	59.88	8821	
12	45.00	43.16	55.74	17.98	203.26	22.08	65.25	8821	
		43.16	55.74	19.58	181.29	19.58	62.74a	9056	
13	44.53	47.82	60.21	21.15	195.86	21.15	68.98a	9486	
14	44.05	52.48	64.61	22.70	210.16	22.70	75.18a	9992	
15	43.85	54.45	66.45	23.34	216.13	23.34	77.79a	10175	
16	43.41	58.76	70.46	24.75	229.19	24.75	83.51a	10576	
17	43.00	62.78	74.19	26.06	241.32	26.06	88.84a	10950	
18	42.50	67.69	78.74	27.66	256.11	27.66	95.35a	11407	
19	42.00	72.59	83.30	29.26	270.94	29.26	101.85a	11863	
20	41.50	77.50	87.88	30.87	285.84	30.87	108.37a	12319	
21	41.13	81.18	91.33	32.08	297.08	35.22	116.39	12661	
22	40.75	84.86	94.80	33.30	308.37	39.49	124.34	13004	

Node no.	Y coord	----- RIGHT side -----						Total earth pressure kN/m2	Coeff. of subgrade reaction kN/m3
		Water press. kN/m2	Vertic -al kN/m2	Effective stresses		Earth pressure kN/m2			
				Active limit kN/m2	Passive limit kN/m2				
1	49.75	0.00	0.00	0.00	0.00	0.00	0.00	0.0	
2	49.40	0.00	0.00	0.00	0.00	0.00	0.00	0.0	
3	49.10	0.00	0.00	0.00	0.00	0.00	0.00	0.0	
4	48.65	0.00	0.00	0.00	0.00	0.00	0.00	0.0	
5	48.20	0.00	0.00	0.00	0.00	0.00	0.00	0.0	
6	47.90	0.00	0.00	0.00	0.00	0.00	0.00	0.0	
7	47.50	0.00	0.00	0.00	0.00	0.00	0.00	0.0	
8	47.00	0.00	0.00	0.00	0.00	0.00	0.00	0.0	
9	46.50	0.00	0.00	0.00	0.00	0.00	0.00	0.0	
10	46.00	0.00	0.00	0.00	0.00	0.00	0.00	0.0	
11	45.50	0.00	0.00	0.00	0.00	0.00	0.00	0.0	
12	45.00	0.00	0.00	0.00	0.00	0.00	0.00	0.0	
13	44.53	0.00	0.00	0.00	0.00	0.00	0.00	0.0	
14	44.05	0.00	0.00	0.00	0.00	0.00	0.00	0.0	
15	43.85	0.00	0.00	0.00	0.00	0.00	0.00	0.0	
		0.00	0.00	0.00	0.00	0.00	0.00	3084	
16	43.41	0.00	7.92	2.67	27.26	6.24	6.24	3084	
		0.00	7.92	2.78	25.76	25.76	25.76p	10576	
17	43.00	0.00	16.12	5.66	52.44	52.44	52.44p	10950	
18	42.50	4.90	21.22	7.45	69.01	69.01	73.92p	11407	
19	42.00	9.81	26.31	9.24	85.59	85.59	95.40p	11863	
20	41.50	14.71	31.41	11.03	102.17	102.17	116.88p	12319	
21	41.13	18.39	35.23	12.38	114.61	111.66	130.05	12661	
22	40.75	22.07	39.06	13.72	127.05	103.56	125.63	13004	

Note: 108.37a Soil pressure at active limit
116.88p Soil pressure at passive limit

Units: kN,m

Stage No.11 Change soil type 3 to soil type 4

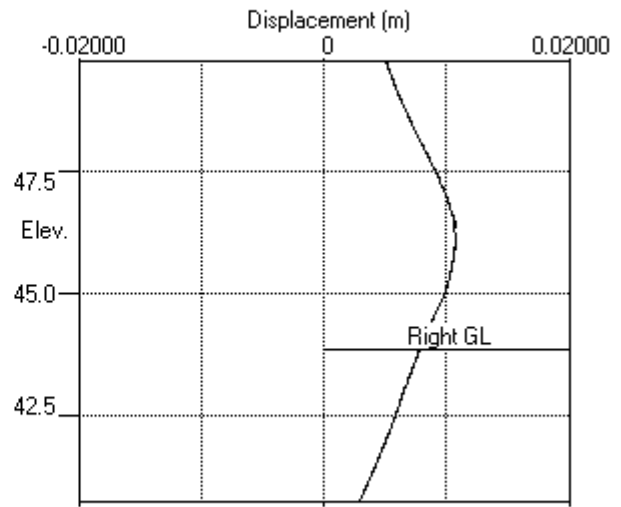
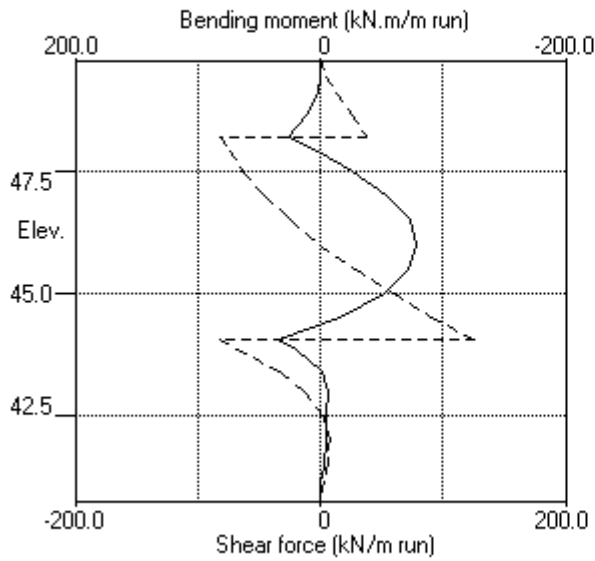

Stage No.11 Change soil type 3 to soil type 4

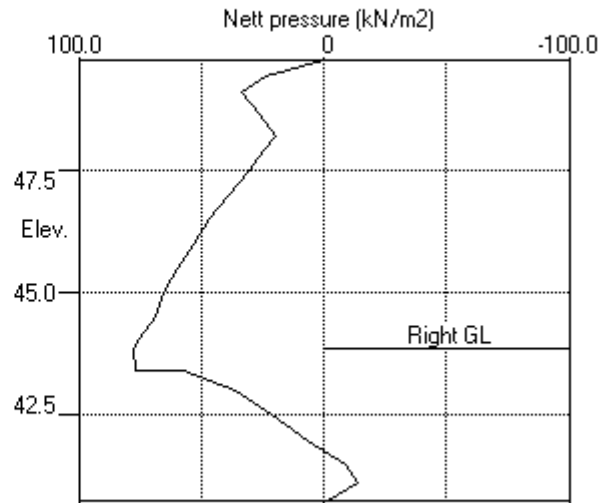
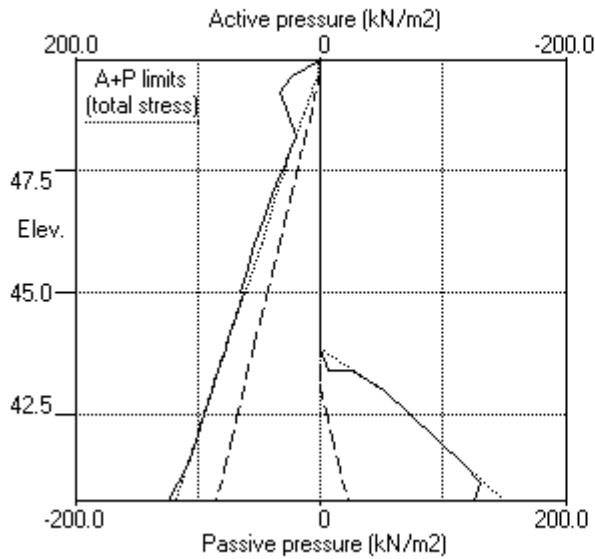

PILEDESIGNS LTD
 Program: WALLAP Version 6.06 Revision A51.B69.R54
 Licensed from GEOSOLVE
 Data filename/Run ID: Hampstead_Wall_3_450mm_rev_01_ULS1
 Hampstead - 24-26 Redington Gardens
 Wall 3, Secant-ULS1, 450 dia @ 650 - run 01

Sheet No.
 Job No. 21495
 Made by : DBS
 Date: 1-10-2018
 Checked :

Units: kN,m

Summary of results

BENDING MOMENT and DISPLACEMENT ANALYSIS of Fully Embedded Wall

Analysis options

Length of wall perpendicular to section = 50.00m
 Subgrade reaction model - Boussinesq Influence coefficients
 Soil deformations are elastic until the active or passive limit is reached
 Open Tension Crack analysis - No

Rigid boundaries: Left side 50.00 from wall
 Right side 50.00 from wall

Limit State: ULS DA1 Combination 1

Calculated Bending Moments and Strut Forces have been multiplied by a factor of 1.35 to obtain values for structural design.

Bending moment, shear force and displacement envelopes

Node no.	Y coord	Displacement		Bending moment				Shear force			
		max. m	min. m	Calculated		Factored		Calculated		Factored	
				max. kN.m/m	min. kN.m/m	max. kN.m/m	min. kN.m/m	max. kN/m	min. kN/m	max. kN/m	min. kN/m
1	49.75	0.012	0.000	0	-0	0	-0	0	0	0	0
2	49.40	0.011	0.000	1	-0	1	-0	5	-1	6	-1
3	49.10	0.010	0.000	3	-0	4	-1	14	-2	19	-3
4	48.65	0.009	0.000	13	-2	17	-2	28	-3	38	-4
5	48.20	0.008	0.000	28	-3	38	-4	38	-91	52	-123
6	47.90	0.008	0.000	12	-3	16	-4	21	-84	28	-114
7	47.50	0.009	0.000	22	-31	30	-41	27	-74	36	-100
8	47.00	0.010	0.000	35	-64	47	-86	24	-58	33	-78
9	46.50	0.011	0.000	45	-88	60	-118	14	-38	19	-52
10	46.00	0.011	0.000	50	-100	67	-134	1	-16	2	-21
11	45.50	0.011	0.000	46	-102	62	-137	28	-11	38	-15
12	45.00	0.010	0.000	39	-90	52	-121	60	-16	80	-22
13	44.53	0.009	0.000	30	-68	40	-92	91	-19	123	-25
14	44.05	0.008	0.000	34	-41	46	-55	125	-83	169	-112
15	43.85	0.008	0.000	20	-27	27	-37	72	-67	97	-91
16	43.41	0.007	0.000	15	-1	20	-1	85	-33	115	-45
17	43.00	0.007	0.000	38	-7	51	-9	41	-14	56	-19
18	42.50	0.006	0.000	48	-5	65	-7	1	-11	1	-14
19	42.00	0.005	0.000	36	-4	49	-6	7	-31	10	-42
20	41.50	0.004	0.000	17	-2	24	-3	7	-34	9	-46
21	41.13	0.004	0.000	6	-0	8	-0	3	-23	4	-31
22	40.75	0.003	0.000	0	-0	0	-0	0	0	0	0

Summary of results (continued)

Calculated Bending Moments and Strut Forces have been multiplied by a factor of 1.35 to obtain values for structural design.

Maximum and minimum bending moment and shear force at each stage

Stage no.	Bending moment				Shear force			
	Calculated		Factored		Calculated		Factored	
min.	max. elev.	min. elev.	max. elev.	max. elev.	min. elev.	max. elev.	min. elev.	max. elev.
	kN.m/m	kN.m/m	kN.m/m	kN/m	kN/m	kN/m	kN/m	kN/m
1	2 43.41	-3 46.50	3 -4	3 45.00	-1 48.20	4		
-2	2 43.41	-4 46.50	2 -6	4 45.00	-2 47.90	6		
-3	4 44.05	-3 47.90	6 -4	5 45.00	-3 48.65	7		
-4	50 46.00	-0 41.13	67 -0	27 47.50	-19 44.53	36		
-25	No calculation at this stage							
5	41 46.00	-0 49.75	56 -0	21 47.50	-14 44.05	28		
-19	47 42.50	-101 45.50	63 -136	84 43.41	-91 48.20	113		
-122	48 42.50	-102 45.50	65 -137	85 43.41	-91 48.20	115		
-123	No calculation at this stage							
9	46 42.50	-90 45.50	63 -122	69 44.05	-86 48.20	94		
-116	34 44.05	-78 46.00	46 -105	125 44.05	-83 44.05	169		
-112	No calculation at this stage							
12	27 48.20	-83 46.00	37 -113	118 44.05	-83 48.20	160		
-113								

Maximum and minimum displacement at each stage

Stage no.	Displacement				Stage description
	maximum elev.	minimum elev.	maximum elev.	minimum elev.	
	m	m	m	m	
1	0.001 49.75	0.000 49.75	0.000 49.75	0.000 49.75	Apply surcharge no.1 at elev. 49.75
2	0.001 47.50	0.000 49.75	0.000 49.75	0.000 49.75	Apply surcharge no.2 at elev. 49.10
3	0.002 49.75	0.000 49.75	0.000 49.75	0.000 49.75	Apply water pressure profile no.1
4	0.012 49.75	0.000 49.75	0.000 49.75	0.000 49.75	Excav. to elev. 47.90 on RIGHT side
5	No calculation at this stage				Install strut no.1 at elev. 48.20
6	0.011 49.75	0.000 49.75	0.000 49.75	0.000 49.75	Apply water pressure profile no.2
7	0.011 46.00	0.000 49.75	0.000 49.75	0.000 49.75	Excav. to elev. 43.41 on RIGHT side
8	0.011 46.00	0.000 49.75	0.000 49.75	0.000 49.75	Fill to elev. 43.85 on RIGHT side
9	No calculation at this stage				Install strut no.2 at elev. 44.05
10	0.011 46.00	0.000 49.75	0.000 49.75	0.000 49.75	Change EI of wall to 43355kN.m ² /m run
11	0.011 46.00	0.000 49.75	0.000 49.75	0.000 49.75	Change soil type 3 to soil type 4
12	No calculation at this stage				Apply surcharge no.3 at elev. 43.85
13	0.011 46.00	0.000 49.75	0.000 49.75	0.000 49.75	Apply water pressure profile no.3

Strut forces at each stage (horizontal components)

Stage no.	Strut no. 1			Strut no. 2		
	at elev. 48.20			at elev. 44.05		
	Calculated	Factored	Calculated	Factored	Factored	
	kN per m run	kN per strut	kN per strut	kN per m run	kN per strut	kN per strut
6	7	7	9	---	---	---
7	128	128	173	---	---	---
8	128	128	173	---	---	---
10	125	125	168	21	21	29
11	118	118	159	208	208	280
13	121	121	163	160	160	217

Units: kN,m

Bending moment, shear force, displacement envelopes

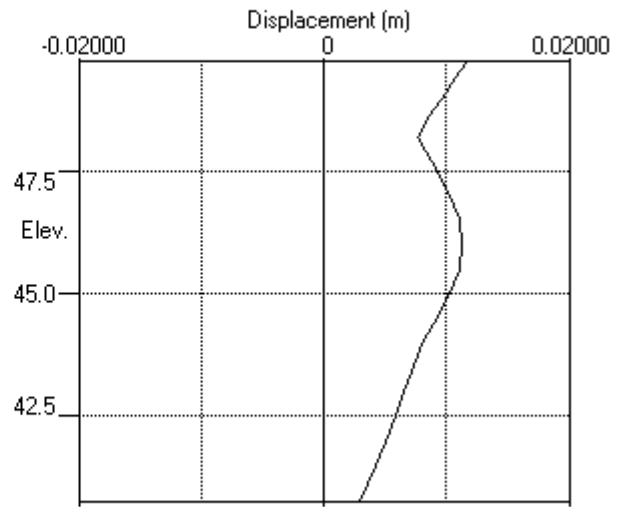
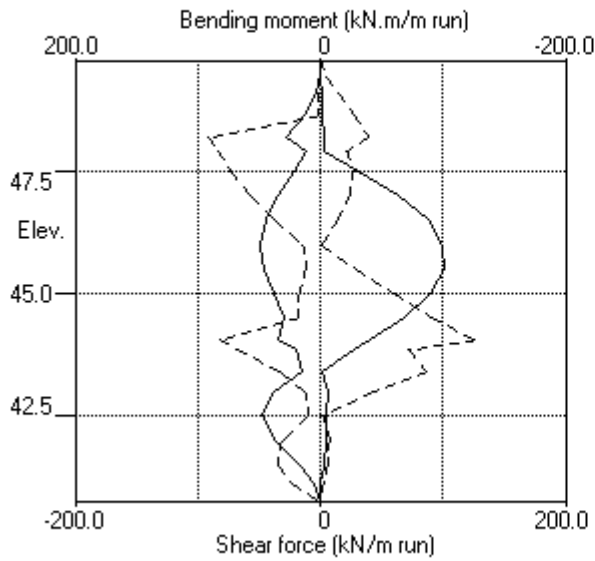



WALLAP

3-ULS2

PILEDESIGNS LTD
 Program: WALLAP Version 6.06 Revision A51.B69.R54
 Licensed from GEOSOLVE
 Data filename/Run ID: Hampstead_Wall_3_450mm_rev_01_ULS2
 Hampstead - 24-26 Redington Gardens
 Wall 3, Secant-ULS2, 450 dia @ 650 - run 01

Sheet No.
 Job No. 21495
 Made by : DBS
 Date: 1-10-2018
 Checked :

Units: kN,m

INPUT DATA

SOIL PROFILE

Stratum no.	Elevation of top of stratum	Soil types	
		Left side	Right side
1	49.75	1 Made Ground dr	1 Made Ground dr
2	47.50	2 Claygate Clay dr	2 Claygate Clay dr
3	45.00	3 London Clay und	3 London Clay und

SOIL PROPERTIES (Unfactored SLS soil strengths)

-- Soil type --	Bulk density	Young's Modulus	At rest coeff.	Consol state.	Active limit	Passive limit	Cohesion
No. Description (Datum elev.)	kN/m3	Eh,kN/m2 (dEh/dy)	Ko (dKo/dy)	NC/OC (Nu)	Ka (Kac)	Kp (Kpc)	kN/m2 (dc/dy)
1 Made Ground dr	18.00	10000	0.530	OC (0.250)	0.337 (0.000)	3.442 (0.000)	
2 Claygate Clay dr	19.00	30000	1.000	NC (0.200)	0.323 (1.330)	3.647 (5.195)	0.0d
3 London Cl.. (45.00)	20.00	40000 (4000)	1.000	OC (0.490)	1.000 (2.476)	1.000 (2.390)	50.00u (5.000)
4 London Cl.. (45.00)	20.00	30800 (3080)	1.000	OC (0.200)	0.351 (1.391)	3.253 (4.831)	0.0d

Additional soil parameters associated with Ka and Kp

No. Description	--- parameters for Ka ---			--- parameters for Kp ---		
	Soil friction angle	Wall adhesion coeff.	Back-fill angle	Soil friction angle	Wall adhesion coeff.	Back-fill angle
1 Made Ground dr	26.00	0.670	0.00	26.00	0.500	0.00
2 Claygate Clay dr	27.00	0.670	0.00	27.00	0.500	0.00
3 London Clay und	0.00	0.670	0.00	0.00	0.500	0.00
4 London Clay dr	25.00	0.670	0.00	25.00	0.500	0.00

GROUND WATER CONDITIONS

Density of water = 9.810 kN/m3

	Left side	Right side
Initial water table elevation	49.40	49.40

Automatic water pressure balancing at toe of wall : No

Water profile no.	Left side				Right side			
	Point no.	Elev. m	Piezo elev. m	Water press. kN/m2	Point no.	Elev. m	Piezo elev. m	Water press. kN/m2
1	1	49.40	49.40	0.0	1	47.50	47.50	0.0 MC+WC
2	1	49.40	49.40	0.0	1	43.00	43.00	0.0 MC+WC
3	1	49.40	49.40	0.0	1	43.85	43.85	0.0 MC+WC
					2	43.85	49.40	54.4

WALL PROPERTIES

Type of structure = Fully Embedded Wall
 Elevation of toe of wall = 40.75
 Maximum finite element length = 0.50 m
 Youngs modulus of wall E = 1.9600E+07 kN/m2
 Moment of inertia of wall I = 3.0968E-03 m4/m run
 E.I = 60696 kN.m2/m run
 Yield Moment of wall = Not defined

STRUTS and ANCHORS

Strut/ anchor no.	Elev.	Strut spacing m	X-section area of strut sq.m	Youngs modulus kN/m ²	Free length m	Inclin -ation (degs)	Pre- stress /strut kN	Tension allowed
1	48.20	1.00	0.300000	1.400E+07	5.00	0.00	0	No
2	44.05	1.00	0.300000	1.400E+07	5.00	0.00	0	No

SURCHARGE LOADS

Surch -arge no.	Elev.	Distance from wall	Length parallel to wall	Width perpend. to wall	Surcharge Near edge kN/m ²	Surcharge Far edge kN/m ²	Equiv. soil type	Partial factor/ Category
1	49.75	0.50(L)	10.00	2.75	13.00	=	N/A	1.30 Var
2	49.10	3.25(L)	10.00	0.50	90.00	=	N/A	1.00 P/U
3	43.85	-0.00(R)	10.00	10.00	55.00	=	N/A	1.00 P/F

Note: L = Left side, R = Right side

Limit State Categories P/U = Permanent Unfavourable
P/F = Permanent Favourable
Var = Variable (unfavourable)

CONSTRUCTION STAGES

Construction stage no.	Stage description
1	Apply surcharge no.1 at elevation 49.75
2	Apply surcharge no.2 at elevation 49.10
3	Apply water pressure profile no.1 (Worst Cred.)
4	Excavate to elevation 47.90 on RIGHT side
5	Install strut or anchor no.1 at elevation 48.20
6	Apply water pressure profile no.2 (Worst Cred.)
7	Excavate to elevation 43.41 on RIGHT side
8	Fill to elevation 43.85 on RIGHT side with soil type 1
9	Install strut or anchor no.2 at elevation 44.05
10	Change EI of wall to 43355 kN.m ² /m run Yield moment not defined Allow wall to relax with new modulus value
11	Change properties of soil type 3 to soil type 4 Ko pressures will not be reset
12	Apply surcharge no.3 at elevation 43.85 No analysis at this stage
13	Apply water pressure profile no.3 (Worst Cred.)

FACTORS OF SAFETY and ANALYSIS OPTIONS

Limit State options: ULS DA1 Combination 2

Water pressures : Worst Credible

Partial factor on C' = 1.250

Partial factor on Phi' = 1.250

Partial factor on Cu = 1.400

Partial factor on Soil Modulus = 1.000

Partial factor on Permanent Unfavourable loads = 1.000

Partial factor on Permanent Favourable loads = 1.000

Partial factor on Variable Unfavourable loads = 1.300

Stability analysis:

Method of analysis - Strength Factor method

Overall factor on soil strength for calculating wall depth = 1.00

Parameters for undrained strata:

Minimum equivalent fluid density = 5.00 kN/m³

Maximum depth of water filled tension crack = 0.00 m

Bending moment and displacement calculation:

Method - Subgrade reaction model using Influence Coefficients

Open Tension Crack analysis? - No

Non-linear Modulus Parameter (L) = 9.000 m

Boundary conditions:

Length of wall (normal to plane of analysis) = 50.00 m

Width of excavation on Left side of wall = 50.00 m

Width of excavation on Right side of wall = 50.00 m

Distance to rigid boundary on Left side = 50.00 m

Distance to rigid boundary on Right side = 50.00 m

OUTPUT OPTIONS

Stage no.	Stage description	Displacement	Active, Passive pressures	Graph. output
1	Apply surcharge no.1 at elev. 49.75	No	No	No
2	Apply surcharge no.2 at elev. 49.10	Yes	Yes	Yes
3	Apply water pressure profile no.1	Yes	Yes	Yes
4	Excav. to elev. 47.90 on RIGHT side	Yes	Yes	Yes
5	Install strut no.1 at elev. 48.20	Yes	Yes	Yes
6	Apply water pressure profile no.2	Yes	Yes	Yes
7	Excav. to elev. 43.41 on RIGHT side	Yes	Yes	Yes
8	Fill to elev. 43.85 on RIGHT side	Yes	Yes	Yes
9	Install strut no.2 at elev. 44.05	Yes	Yes	Yes
10	Change EI of wall to 43355kN.m2/m run	No	No	No
11	Change soil type 3 to soil type 4	No	No	No
12	Apply surcharge no.3 at elev. 43.85	No	No	No
13	Apply water pressure profile no.3	No	No	No
*	Summary output	Yes	-	Yes

Program WALLAP - Copyright (C) 2017 by DL Borin, distributed by GEOSOLVE
 150 St. Alphonsus Road, London SW4 7BW, UK www.geosolve.co.uk

Units: kN,m

Stage No.13 Apply water pressure profile no.3 (Worst Cred.)

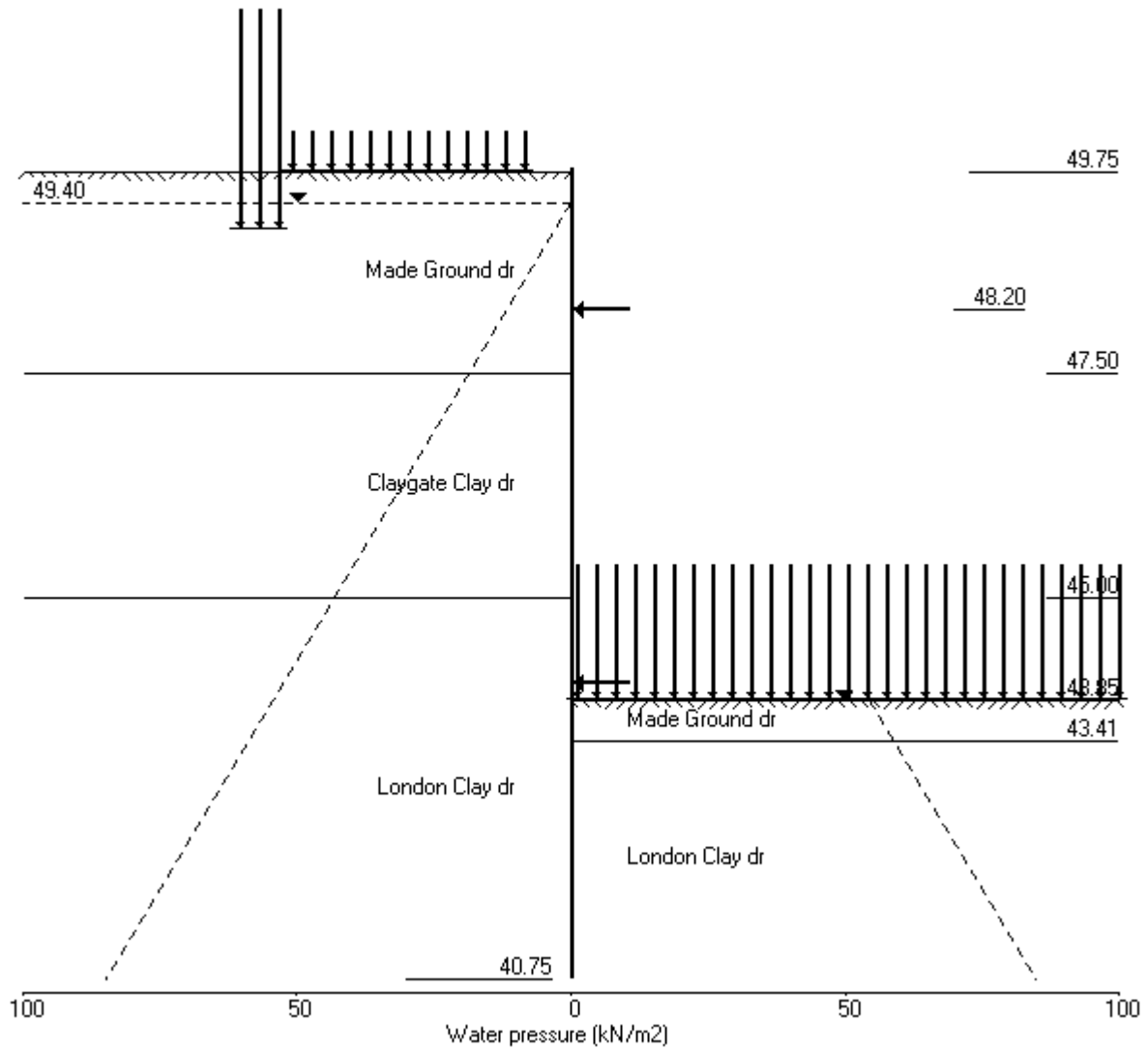

PILEDESIGNS LTD
 Program: WALLAP Version 6.06 Revision A51.B69.R54
 Licensed from GEOSOLVE
 Data filename/Run ID: Hampstead_Wall_3_450mm_rev_01_ULS2
 Hampstead - 24-26 Redington Gardens
 Wall 3, Secant-ULS2, 450 dia @ 650 - run 01

Sheet No.
 Job No. 21495
 Made by : DBS
 Date: 1-10-2018
 Checked :

Units: kN,m

Stage No. 4 Excavate to elevation 47.90 on RIGHT side

STABILITY ANALYSIS of Fully Embedded Wall according to Strength Factor method
 Factor of safety on soil strength

			Overall		Toe elev. for			
			FoS for toe		FoS = 1.000			
			elev. = 40.75					
Stage No.	--- G.L. --- Act. Pass.	Strut Elev.	Factor of Safety	Moment of equil. at elev.	Toe elev.	Wall Penetr-ation	Direction of failure	
4	49.75 47.90	Cant.	1.642	41.78	43.16	4.74	L to R	

BENDING MOMENT and DISPLACEMENT ANALYSIS of Fully Embedded Wall

Analysis options

Length of wall perpendicular to section = 50.00m

Subgrade reaction model - Boussinesq Influence coefficients

Soil deformations are elastic until the active or passive limit is reached

Open Tension Crack analysis - No

Rigid boundaries: Left side 50.00 from wall

Right side 50.00 from wall

Limit State: ULS DA1 Combination 2

Node no.	Y coord	Nett pressure kN/m2	Wall disp. m	Wall rotation rad.	Shear force kN/m	Bending moment kN.m/m	Strut forces kN/m	EI of wall kN.m2/m
1	49.75	0.00	0.023	5.02E-03	0.0	-0.0		60696
2	49.40	3.20	0.022	5.02E-03	0.6	0.2		60696
3	49.10	8.41	0.020	5.02E-03	2.3	0.6		60696
4	48.65	15.75	0.018	5.00E-03	7.7	2.7		60696
5	48.20	22.46	0.016	4.97E-03	16.3	8.0		60696
6	47.90	26.75	0.014	4.91E-03	23.7	14.0		60696
7	47.50	13.17	0.012	4.78E-03	31.7	25.3		60696
		11.79	0.012	4.78E-03	31.7	25.3		
8	47.00	1.06	0.010	4.50E-03	34.9	42.0		60696
9	46.50	-9.80	0.008	4.09E-03	32.7	59.0		60696
10	46.00	-20.76	0.006	3.54E-03	25.1	73.6		60696
11	45.50	-31.82	0.004	2.90E-03	11.9	83.0		60696
12	45.00	-31.04	0.003	2.20E-03	-3.8	86.8		60696
		-63.05	0.003	2.20E-03	-3.8	86.8		
13	44.53	-30.12	0.002	1.55E-03	-25.9	77.9		60696
14	44.05	-7.11	0.001	1.01E-03	-34.7	62.2		60696
15	43.85	-0.16	0.001	8.17E-04	-35.5	55.1		60696
16	43.41	10.23	0.001	4.74E-04	-33.2	39.4		60696
17	43.00	14.98	0.001	2.51E-04	-28.1	26.6		60696
18	42.50	16.29	0.001	8.21E-05	-20.3	14.5		60696
19	42.00	14.56	0.001	-3.52E-06	-12.5	6.3		60696
20	41.50	11.21	0.001	-3.72E-05	-6.1	1.9		60696
21	41.13	8.23	0.001	-4.41E-05	-2.5	0.4		60696
22	40.75	4.88	0.001	-4.52E-05	0.0	0.0		---

(continued)

Stage No.4 Excavate to elevation 47.90 on RIGHT side

Node no.	Y coord	LEFT side					Total earth pressure kN/m2	Coeff. of subgrade reaction kN/m3
		Water press. kN/m2	Vertic -al kN/m2	Effective Active limit kN/m2	Effective Passive limit kN/m2	Earth pressure kN/m2		
1	49.75	0.00	0.00	0.00	0.00	0.00	0.00	3377
2	49.40	0.00	7.81	3.20	20.79	3.20	3.20a	3377
3	49.10	2.94	13.34	5.47	35.54	5.47	8.41a	3377
4	48.65	7.36	20.45	8.39	54.48	8.39	15.75a	3377
5	48.20	11.77	26.06	10.69	69.43	10.69	22.46a	3377
6	47.90	14.71	29.35	12.04	78.19	12.04	26.75a	3377
7	47.50	18.64	33.42	13.71	89.04	13.71	32.35a	3377
		18.64	33.42	13.22	93.19	13.22	31.86a	9743
8	47.00	23.54	38.68	15.30	107.83	15.30	38.85a	9743
9	46.50	28.45	43.63	17.26	121.63	17.26	45.71a	9743
10	46.00	33.35	48.30	19.11	134.65	19.11	52.46a	9743
11	45.50	38.26	52.73	20.86	147.02	20.86	59.12a	9743
12	45.00	43.16	56.98	22.54	158.86	32.32	75.48	9743
		Total>	100.15	23.75m	185.51	51.38	51.38	18883
13	44.53	Total>	109.19	26.12m	198.61	75.22	75.22	19780
14	44.05	Total>	118.16	28.50m	211.64	94.67	94.67	20677
15	43.85	Total>	121.92	29.50m	217.10	101.64	101.64	21055
16	43.41	Total>	130.17	31.70m	229.12	114.81	114.81	21886
17	43.00	Total>	137.86	33.75m	240.30	124.91	124.91	22660
18	42.50	Total>	147.24	36.67	253.95	135.24	135.24	23604
19	42.00	Total>	156.64	41.65	267.62	144.24	144.24	24549
20	41.50	Total>	166.06	46.65	281.31	152.53	152.53	25493
21	41.13	Total>	173.16	50.43	291.61	158.56	158.56	26201
22	40.75	Total>	180.27	54.22	301.92	164.42	164.42	26909

Node no.	Y coord	RIGHT side					Total earth pressure kN/m2	Coeff. of subgrade reaction kN/m3
		Water press. kN/m2	Vertic -al kN/m2	Effective Active limit kN/m2	Effective Passive limit kN/m2	Earth pressure kN/m2		
1	49.75	0.00	0.00	0.00	0.00	0.00	0.00	0.0
2	49.40	0.00	0.00	0.00	0.00	0.00	0.00	0.0
3	49.10	0.00	0.00	0.00	0.00	0.00	0.00	0.0
4	48.65	0.00	0.00	0.00	0.00	0.00	0.00	0.0
5	48.20	0.00	0.00	0.00	0.00	0.00	0.00	0.0
6	47.90	0.00	0.00	0.00	0.00	0.00	0.00	0.0
		0.00	0.00	0.00	0.00	0.00	0.00	4425
7	47.50	0.00	7.20	2.95	19.18	19.18	19.18p	4425
		0.00	7.20	2.85	20.07	20.07	20.07p	12791
8	47.00	4.90	11.80	4.67	32.88	32.88	37.79p	12791
9	46.50	9.81	16.39	6.48	45.70	45.70	55.51p	12791
10	46.00	14.71	20.99	8.30	58.51	58.51	73.22p	12791
11	45.50	19.62	25.58	10.12	71.32	71.32	90.94p	12791
12	45.00	24.52	30.18	11.94	84.13	81.99	106.52	12791
		Total>	54.70	14.50m	140.07	114.42	114.42	24316
13	44.53	Total>	64.20	16.88m	153.62	105.34	105.34	25471
14	44.05	Total>	73.71	19.25m	167.18	101.78	101.78	26626
15	43.85	Total>	77.71	20.25m	172.89	101.80	101.80	27112
16	43.41	Total>	86.51	22.45m	185.45	104.59	104.59	28182
17	43.00	Total>	94.71	24.50m	197.15	109.93	109.93	29179
18	42.50	Total>	104.72	27.00m	211.42	118.95	118.95	30395
19	42.00	Total>	114.72	29.50m	225.70	129.67	129.67	31611
20	41.50	Total>	124.73	32.00m	239.97	141.32	141.32	32826
21	41.13	Total>	132.23	33.88m	250.68	150.32	150.32	33738

Run ID. Hampstead_Wall_3_450mm_rev_01_ULS2
 Hampstead - 24-26 Redington Gardens
 Wall 3, Secant-ULS2, 450 dia @ 650 - run 01

| Sheet No.
 | Date: 1-10-2018
 | Checked :

(continued)

Stage No.4 Excavate to elevation 47.90 on RIGHT side

Node no.	Y coord	----- RIGHT side -----					Total earth pressure kN/m2	Coeff. of subgrade reaction kN/m3
		Water press. kN/m2	Vertic -al kN/m2	Effective Active limit kN/m2	Effective Passive limit kN/m2	Earth pressure kN/m2		
22	40.75	Total>	139.74	35.75m	261.39	159.54	159.54	34650

Note: 59.12a Soil pressure at active limit
 90.94p Soil pressure at passive limit

Units: kN,m

Stage No.4 Excav. to elev. 47.90 on RIGHT side

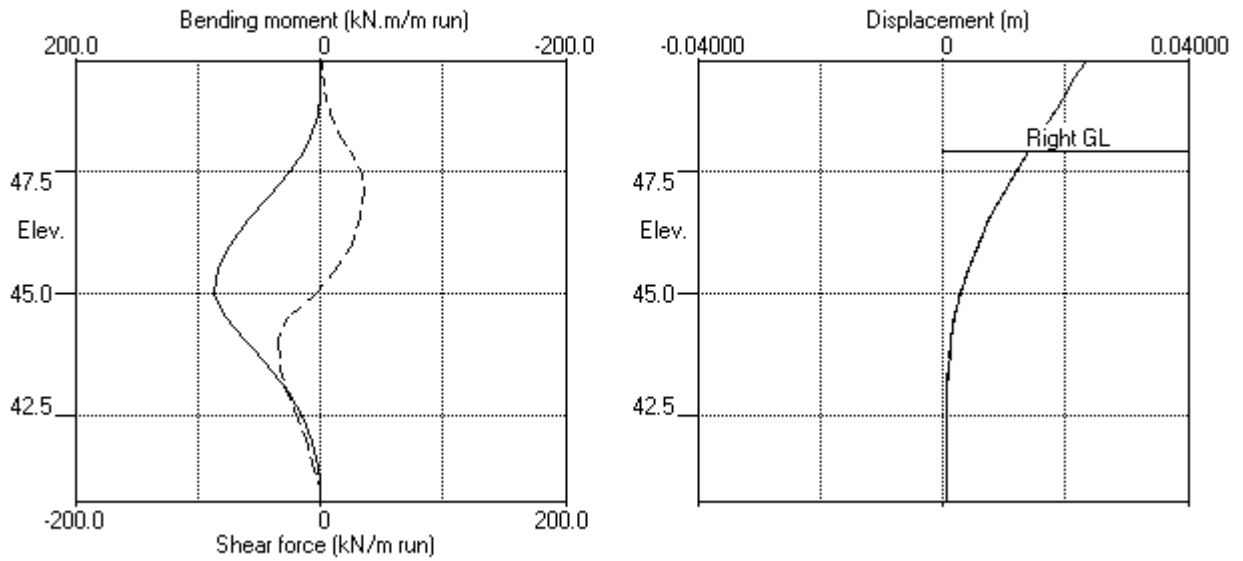

Stage No.4 Excav. to elev. 47.90 on RIGHT side

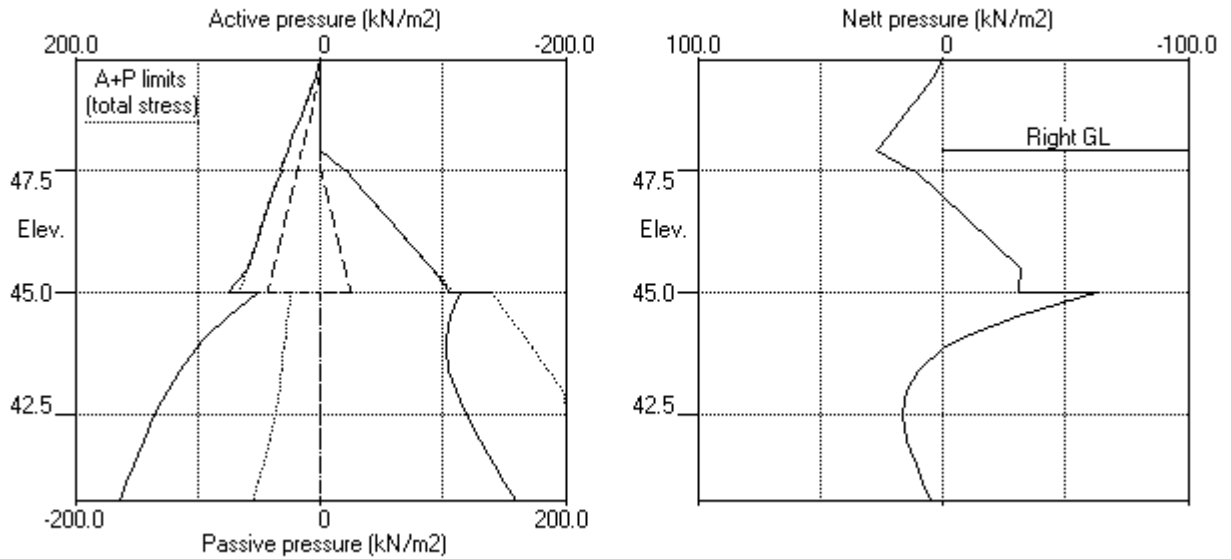

PILEDESIGNS LTD
 Program: WALLAP Version 6.06 Revision A51.B69.R54
 Licensed from GEOSOLVE
 Data filename/Run ID: Hampstead_Wall_3_450mm_rev_01_ULS2
 Hampstead - 24-26 Redington Gardens
 Wall 3, Secant-ULS2, 450 dia @ 650 - run 01

Sheet No.
 Job No. 21495
 Made by : DBS
 Date: 1-10-2018
 Checked :

Units: kN,m

Stage No. 7 Excavate to elevation 43.41 on RIGHT side

STABILITY ANALYSIS of Fully Embedded Wall according to Strength Factor method
 Factor of safety on soil strength

			Overall							
			FoS for toe	Toe elev. for						
			elev. = 40.75	FoS = 1.000						

Stage No.	--- G.L. Act.	--- Pass.	Strut Elev.	Factor of Safety	Moment of equil. at elev.	Toe elev.	Wall Penetr-ation	Direction of failure		
7	49.75	43.41	48.20	1.380	n/a	42.39	1.02	L to R		

BENDING MOMENT and DISPLACEMENT ANALYSIS of Fully Embedded Wall

Analysis options

Length of wall perpendicular to section = 50.00m
 Subgrade reaction model - Boussinesq Influence coefficients
 Soil deformations are elastic until the active or passive limit is reached
 Open Tension Crack analysis - No

Rigid boundaries: Left side 50.00 from wall
 Right side 50.00 from wall

Limit State: ULS DA1 Combination 2

Node no.	Y coord	Nett pressure kN/m2	Wall disp. m	Wall rotation rad.	Shear force kN/m	Bending moment kN.m/m	Strut forces kN/m	EI of wall kN.m2/m
1	49.75	0.00	0.014	-1.10E-03	0.0	-0.0		60696
2	49.40	20.79	0.014	-1.10E-03	3.6	0.5		60696
3	49.10	38.48	0.015	-1.11E-03	12.5	2.8		60696
4	48.65	33.66	0.015	-1.16E-03	28.8	11.6		60696
5	48.20	22.46	0.016	-1.31E-03	41.4	28.2	141.6	60696
		22.46	0.016	-1.31E-03	-100.2	28.2		
6	47.90	26.75	0.016	-1.38E-03	-92.8	-0.8		60696
7	47.50	32.35	0.017	-1.26E-03	-81.0	-35.6		60696
		31.86	0.017	-1.26E-03	-81.0	-35.6		
8	47.00	38.85	0.017	-8.18E-04	-63.3	-71.9		60696
9	46.50	45.71	0.017	-1.16E-04	-42.2	-98.5		60696
10	46.00	52.46	0.017	7.58E-04	-17.7	-113.8		60696
11	45.50	59.12	0.017	1.70E-03	10.2	-115.9		60696
12	45.00	65.71	0.016	2.59E-03	41.4	-101.2		60696
		23.75	0.016	2.59E-03	41.4	-101.2		
13	44.53	26.12	0.014	3.30E-03	53.3	-80.1		60696
14	44.05	28.50	0.012	3.82E-03	66.3	-52.7		60696
15	43.85	29.50	0.012	3.97E-03	72.1	-38.9		60696
16	43.41	31.70	0.010	4.13E-03	85.5	-4.6		60696
		-67.23	0.010	4.13E-03	85.5	-4.6		
17	43.00	-76.88	0.008	4.06E-03	56.0	24.3		60696
18	42.50	-83.65	0.006	3.77E-03	15.8	46.1		60696
19	42.00	-61.59	0.004	3.40E-03	-20.5	43.4		60696
20	41.50	-22.75	0.003	3.11E-03	-41.5	29.4		60696
21	41.13	35.66	0.002	2.98E-03	-39.1	12.2		60696
22	40.75	173.03	0.001	2.94E-03	0.0	0.0		---

At elev. 48.20 Strut force = 141.6 kN/strut = 141.6 kN/m run

(continued)

Stage No.7 Excavate to elevation 43.41 on RIGHT side

Node no.	Y coord	LEFT side					Total earth pressure kN/m2	Coeff. of subgrade reaction kN/m3
		Water press. kN/m2	Vertic -al kN/m2	Effective Active limit kN/m2	Effective Passive limit kN/m2	Earth pressure kN/m2		
1	49.75	0.00	0.00	0.00	0.00	0.00	0.00	6807
2	49.40	0.00	7.81	3.20	20.79	20.79	20.79p	6807
3	49.10	2.94	13.34	5.47	35.54	35.54	38.48p	6807
4	48.65	7.36	20.45	8.39	54.48	26.31	33.66	6807
5	48.20	11.77	26.06	10.69	69.43	10.69	22.46a	2311
6	47.90	14.71	29.35	12.04	78.19	12.04	26.75a	2311
7	47.50	18.64	33.42	13.71	89.04	13.71	32.35a	2311
		18.64	33.42	13.22	93.19	13.22	31.86a	6638
8	47.00	23.54	38.68	15.30	107.83	15.30	38.85a	6638
9	46.50	28.45	43.63	17.26	121.63	17.26	45.71a	6638
10	46.00	33.35	48.30	19.11	134.65	19.11	52.46a	6638
11	45.50	38.26	52.73	20.86	147.02	20.86	59.12a	6638
12	45.00	43.16	56.98	22.54	158.86	22.54	65.71a	6638
		Total>	100.15	23.75m	185.51	23.75	23.75a	13421
13	44.53	Total>	109.19	26.12m	198.61	26.12	26.12a	14058
14	44.05	Total>	118.16	28.50m	211.64	28.50	28.50a	14696
15	43.85	Total>	121.92	29.50m	217.10	29.50	29.50a	14964
16	43.41	Total>	130.17	31.70m	229.12	31.70	31.70a	15555
17	43.00	Total>	137.86	33.75m	240.30	33.75	33.75a	16105
18	42.50	Total>	147.24	36.67	253.95	41.25	41.25	16776
19	42.00	Total>	156.64	41.65	267.62	77.58	77.58	17447
20	41.50	Total>	166.06	46.65	281.31	113.00	113.00	18118
21	41.13	Total>	173.16	50.43	291.61	139.45	139.45	18621
22	40.75	Total>	180.27	54.22	301.92	194.85	194.85	296978

Node no.	Y coord	RIGHT side					Total earth pressure kN/m2	Coeff. of subgrade reaction kN/m3
		Water press. kN/m2	Vertic -al kN/m2	Effective Active limit kN/m2	Effective Passive limit kN/m2	Earth pressure kN/m2		
1	49.75	0.00	0.00	0.00	0.00	0.00	0.00	0.0
2	49.40	0.00	0.00	0.00	0.00	0.00	0.00	0.0
3	49.10	0.00	0.00	0.00	0.00	0.00	0.00	0.0
4	48.65	0.00	0.00	0.00	0.00	0.00	0.00	0.0
5	48.20	0.00	0.00	0.00	0.00	0.00	0.00	0.0
6	47.90	0.00	0.00	0.00	0.00	0.00	0.00	0.0
7	47.50	0.00	0.00	0.00	0.00	0.00	0.00	0.0
8	47.00	0.00	0.00	0.00	0.00	0.00	0.00	0.0
9	46.50	0.00	0.00	0.00	0.00	0.00	0.00	0.0
10	46.00	0.00	0.00	0.00	0.00	0.00	0.00	0.0
11	45.50	0.00	0.00	0.00	0.00	0.00	0.00	0.0
12	45.00	0.00	0.00	0.00	0.00	0.00	0.00	0.0
13	44.53	0.00	0.00	0.00	0.00	0.00	0.00	0.0
14	44.05	0.00	0.00	0.00	0.00	0.00	0.00	0.0
15	43.85	0.00	0.00	0.00	0.00	0.00	0.00	0.0
16	43.41	0.00	0.00	0.00	0.00	0.00	0.00	0.0
		Total>	0.00	0.00	98.93	98.93	98.93p	31406
17	43.00	Total>	8.20	2.05m	110.63	110.63	110.63p	32517
18	42.50	Total>	18.20	4.55m	124.90	124.90	124.90p	33872
19	42.00	Total>	28.20	7.05m	139.17	139.17	139.17p	35227
20	41.50	Total>	38.20	9.55m	153.44	135.75	135.75	36582
21	41.13	Total>	45.70	11.42m	164.14	103.79	103.79	37598
22	40.75	Total>	53.21	13.30m	174.85	21.81	21.81	523196

Run ID. Hampstead_Wall_3_450mm_rev_01_ULS2
Hampstead - 24-26 Redington Gardens
Wall 3, Secant-ULS2, 450 dia @ 650 - run 01

| Sheet No.
| Date: 1-10-2018
| Checked :

(continued)

Stage No.7 Excavate to elevation 43.41 on RIGHT side
Note: 33.75a Soil pressure at active limit
139.17p Soil pressure at passive limit

Units: kN,m

Stage No.7 Excav. to elev. 43.41 on RIGHT side

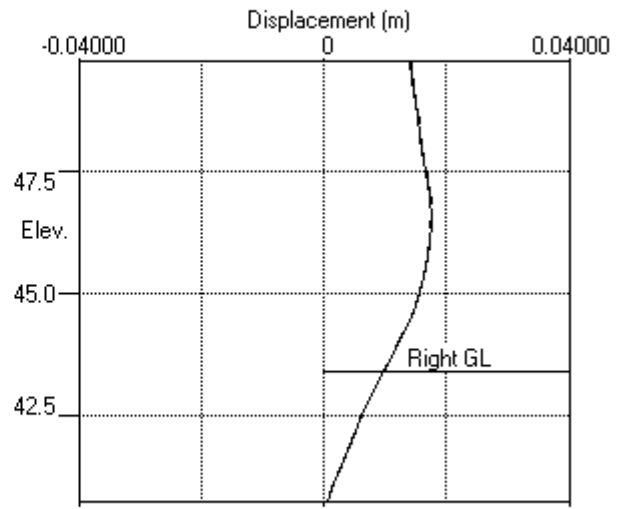
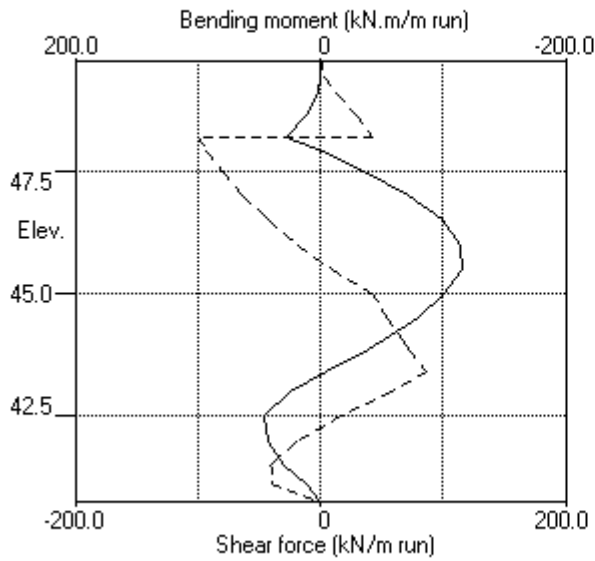

Stage No.7 Excav. to elev. 43.41 on RIGHT side

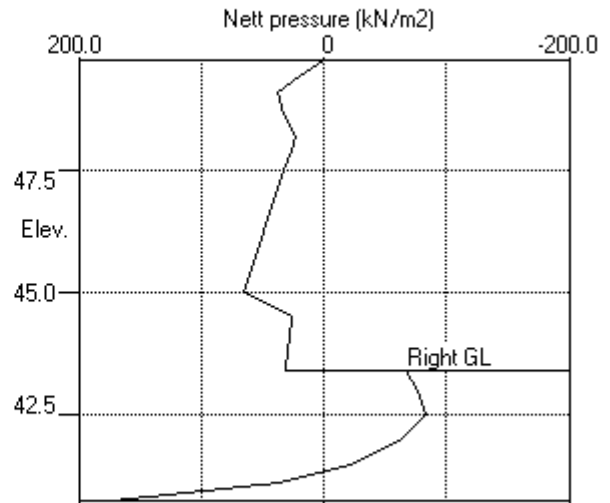
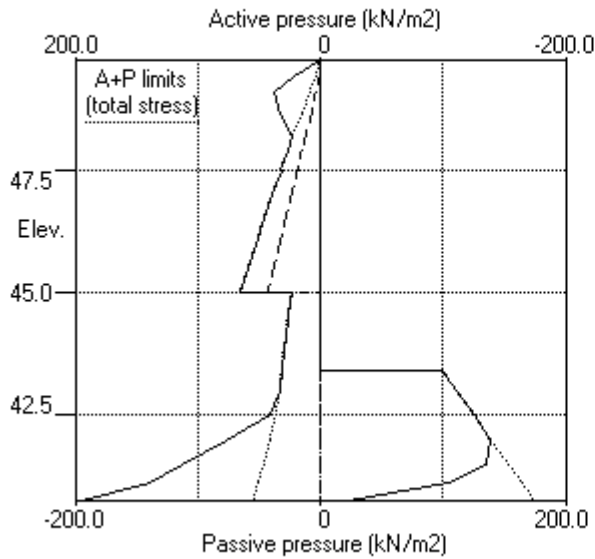

PILEDESIGNS LTD
 Program: WALLAP Version 6.06 Revision A51.B69.R54
 Licensed from GEOSOLVE
 Data filename/Run ID: Hampstead_Wall_3_450mm_rev_01_ULS2
 Hampstead - 24-26 Redington Gardens
 Wall 3, Secant-ULS2, 450 dia @ 650 - run 01

Sheet No.
 Job No. 21495
 Made by : DBS
 Date: 1-10-2018
 Checked :

Units: kN,m

Stage No. 8 Fill to elevation 43.85 on RIGHT side with soil type 1

STABILITY ANALYSIS of Fully Embedded Wall according to Strength Factor method
 Factor of safety on soil strength

		Overall							
		FoS for toe		Toe elev. for					
		elev. = 40.75		FoS = 1.000					
		-----		-----					
Stage	--- G.L. ---	Strut	Factor	Moment	Toe	Wall	Direction		
No.	Act. Pass.	Elev.	of	equilib.	elev.	Penetr	of		
			Safety	at elev.		-ation	failure		
8	49.75 43.85	48.20	1.446	n/a	42.50	1.35	L to R		

BENDING MOMENT and DISPLACEMENT ANALYSIS of Fully Embedded Wall

Analysis options

Length of wall perpendicular to section = 50.00m

Subgrade reaction model - Boussinesq Influence coefficients

Soil deformations are elastic until the active or passive limit is reached

Open Tension Crack analysis - No

Rigid boundaries: Left side 50.00 from wall
 Right side 50.00 from wall

Limit State: ULS DA1 Combination 2

Node no.	Y coord	Nett pressure kN/m2	Wall disp. m	Wall rotation rad.	Shear force kN/m	Bending moment kN.m/m	Strut forces kN/m	EI of wall kN.m2/m
1	49.75	0.00	0.014	-1.09E-03	0.0	-0.0		60696
2	49.40	20.75	0.014	-1.10E-03	3.6	0.5		60696
3	49.10	38.45	0.015	-1.10E-03	12.5	2.8		60696
4	48.65	33.65	0.015	-1.16E-03	28.7	11.6		60696
5	48.20	22.46	0.016	-1.30E-03	41.4	28.1	142.0	60696
		22.46	0.016	-1.30E-03	-100.6	28.1		
6	47.90	26.76	0.016	-1.37E-03	-93.2	-1.0		60696
7	47.50	32.36	0.017	-1.25E-03	-81.4	-35.9		60696
		31.89	0.017	-1.25E-03	-81.4	-35.9		
8	47.00	38.91	0.017	-8.07E-04	-63.7	-72.4		60696
9	46.50	45.82	0.017	-1.01E-04	-42.5	-99.2		60696
10	46.00	52.65	0.017	7.79E-04	-17.9	-114.6		60696
11	45.50	59.41	0.017	1.73E-03	10.1	-116.8		60696
12	45.00	66.12	0.015	2.63E-03	41.5	-102.1		60696
		24.57	0.015	2.63E-03	41.5	-102.1		
13	44.53	27.29	0.014	3.35E-03	53.8	-80.9		60696
14	44.05	30.10	0.012	3.87E-03	67.4	-53.1		60696
15	43.85	31.29	0.012	4.02E-03	73.6	-39.0		60696
16	43.41	30.71	0.010	4.18E-03	87.2	-4.1		60696
		-70.32	0.010	4.18E-03	87.2	-4.1		
17	43.00	-79.11	0.008	4.11E-03	56.6	25.3		60696
18	42.50	-84.92	0.006	3.81E-03	15.6	47.2		60696
19	42.00	-62.00	0.004	3.43E-03	-21.2	44.2		60696
20	41.50	-22.38	0.003	3.13E-03	-42.2	29.7		60696
21	41.13	36.59	0.001	3.00E-03	-39.6	12.3		60696
22	40.75	174.53	0.000	2.96E-03	0.0	0.0		---

At elev. 48.20 Strut force = 142.0 kN/strut = 142.0 kN/m run

(continued)

Stage No.8 Fill to elevation 43.85 on RIGHT side with soil type 1

Node no.	Y coord	LEFT side					Total earth pressure	Coeff. of subgrade reaction
		Water press. kN/m2	Vertic -al kN/m2	Effective Active limit kN/m2	Effective Passive limit kN/m2	Earth pressure kN/m2		
1	49.75	0.00	0.00	0.00	0.00	0.00	0.00	6456
2	49.40	0.00	7.81	3.20	20.79	20.75	20.75	6456
3	49.10	2.94	13.34	5.47	35.54	35.50	38.45	6456
4	48.65	7.36	20.45	8.39	54.48	26.29	33.65	6456
5	48.20	11.77	26.06	10.69	69.43	10.69	22.46a	6456
6	47.90	14.71	29.35	12.04	78.19	12.04	26.76a	2795
7	47.50	18.64	33.42	13.71	89.04	13.72	32.36	2795
		18.64	33.42	13.22	93.19	13.25	31.89	8048
8	47.00	23.54	38.68	15.30	107.83	15.37	38.91	8048
9	46.50	28.45	43.63	17.26	121.63	17.38	45.82	8048
10	46.00	33.35	48.30	19.11	134.65	19.30	52.65	8048
11	45.50	38.26	52.73	20.86	147.02	21.15	59.41	8048
12	45.00	43.16	56.98	22.54	158.86	22.96	66.12	8048
		Total>	100.15	23.75m	185.51	24.57	24.57	15884
13	44.53	Total>	109.19	26.12m	198.61	27.29	27.29	16638
14	44.05	Total>	118.16	28.50m	211.64	30.10	30.10	17393
15	43.85	Total>	121.92	29.50m	217.10	31.29	31.29	17710
16	43.41	Total>	130.17	31.70m	229.12	33.96	33.96	18409
17	43.00	Total>	137.86	33.75m	240.30	36.43	36.43	19061
18	42.50	Total>	147.24	36.67	253.95	44.41	44.41	19855
19	42.00	Total>	156.64	41.65	267.62	81.17	81.17	20649
20	41.50	Total>	166.06	46.65	281.31	116.98	116.98	21443
21	41.13	Total>	173.16	50.43	291.61	143.72	143.72	22039
22	40.75	Total>	180.27	54.22	301.92	199.40	199.40	22634

Node no.	Y coord	RIGHT side					Total earth pressure	Coeff. of subgrade reaction
		Water press. kN/m2	Vertic -al kN/m2	Effective Active limit kN/m2	Effective Passive limit kN/m2	Earth pressure kN/m2		
1	49.75	0.00	0.00	0.00	0.00	0.00	0.00	0.0
2	49.40	0.00	0.00	0.00	0.00	0.00	0.00	0.0
3	49.10	0.00	0.00	0.00	0.00	0.00	0.00	0.0
4	48.65	0.00	0.00	0.00	0.00	0.00	0.00	0.0
5	48.20	0.00	0.00	0.00	0.00	0.00	0.00	0.0
6	47.90	0.00	0.00	0.00	0.00	0.00	0.00	0.0
7	47.50	0.00	0.00	0.00	0.00	0.00	0.00	0.0
8	47.00	0.00	0.00	0.00	0.00	0.00	0.00	0.0
9	46.50	0.00	0.00	0.00	0.00	0.00	0.00	0.0
10	46.00	0.00	0.00	0.00	0.00	0.00	0.00	0.0
11	45.50	0.00	0.00	0.00	0.00	0.00	0.00	0.0
12	45.00	0.00	0.00	0.00	0.00	0.00	0.00	0.0
13	44.53	0.00	0.00	0.00	0.00	0.00	0.00	0.0
14	44.05	0.00	0.00	0.00	0.00	0.00	0.00	0.0
15	43.85	0.00	0.00	0.00	0.00	0.00	0.00	0.0
		0.00	0.00	0.00	0.00	0.00	0.00	2804
16	43.41	0.00	7.92	3.25	21.10	3.25	3.25a	2804
		Total>	7.92	2.20m	106.85	104.27	104.27	18462
17	43.00	Total>	16.12	4.25m	118.55	115.55	115.55	19115
18	42.50	Total>	26.12	6.75m	132.82	129.33	129.33	19912
19	42.00	Total>	36.12	9.25m	147.09	143.17	143.17	20708
20	41.50	Total>	46.12	11.75m	161.36	139.37	139.37	21504
21	41.13	Total>	53.63	13.62m	172.07	107.13	107.13	22102
22	40.75	Total>	61.13	15.50m	182.77	24.86	24.86	22699

Run ID. Hampstead_Wall_3_450mm_rev_01_ULS2
Hampstead - 24-26 Redington Gardens
Wall 3, Secant-ULS2, 450 dia @ 650 - run 01

| Sheet No.
| Date: 1-10-2018
| Checked :

(continued)

Stage No.8 Fill to elevation 43.85 on RIGHT side with soil type 1
Note: 3.25a Soil pressure at active limit
 123.45p Soil pressure at passive limit

Units: kN,m

Stage No.8 Fill to elev. 43.85 on RIGHT side

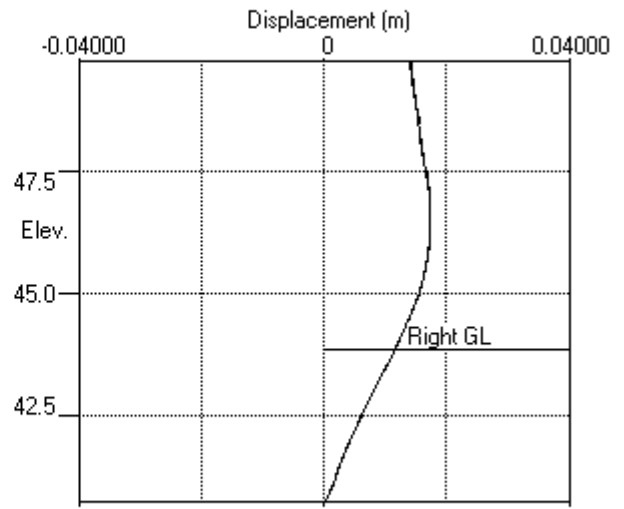
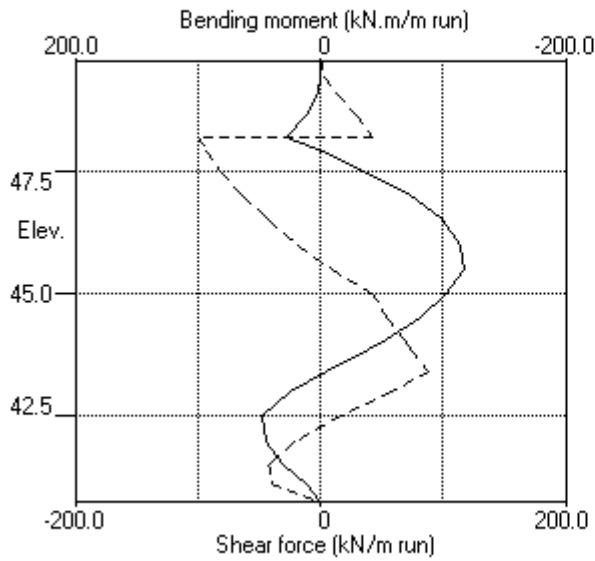

Stage No.8 Fill to elev. 43.85 on RIGHT side

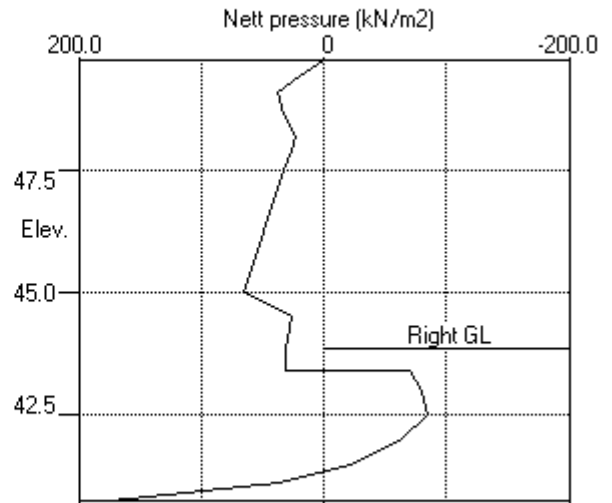
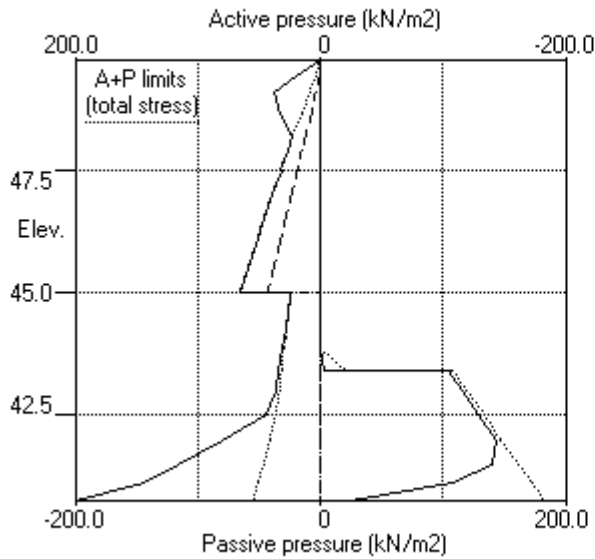

PILEDESIGNS LTD
 Program: WALLAP Version 6.06 Revision A51.B69.R54
 Licensed from GEOSOLVE
 Data filename/Run ID: Hampstead_Wall_3_450mm_rev_01_ULS2
 Hampstead - 24-26 Redington Gardens
 Wall 3, Secant-ULS2, 450 dia @ 650 - run 01

Sheet No.
 Job No. 21495
 Made by : DBS
 Date: 1-10-2018
 Checked :

Units: kN,m

Stage No. 10 Change EI of wall to 43355 kN.m2/m run
 Yield moment not defined
 Allow wall to relax with new modulus value

STABILITY ANALYSIS of Fully Embedded Wall according to Strength Factor method
 Factor of safety on soil strength

		Overall					
		FoS for toe		Toe elev. for			
		elev. = 40.75		FoS = 1.000			
		-----		-----			
Stage No.	--- G.L. --- Act. Pass.	Strut Elev.	Factor of Safety	Moment of equil. at elev.	Toe elev.	Wall Penetr -ation	Direction of failure
10	49.75 43.85		More than one strut.	No FoS calc.			

BENDING MOMENT and DISPLACEMENT ANALYSIS of Fully Embedded Wall

Analysis options

Length of wall perpendicular to section = 50.00m
 Subgrade reaction model - Boussinesq Influence coefficients
 Soil deformations are elastic until the active or passive limit is reached
 Open Tension Crack analysis - No

Rigid boundaries: Left side 50.00 from wall
 Right side 50.00 from wall

Limit State: ULS DA1 Combination 2

Node no.	Y coord	Nett pressure kN/m2	Wall disp. m	Wall rotation rad.	Shear force kN/m	Bending moment kN.m/m	Strut forces kN/m	EI of wall kN.m2/m
1	49.75	0.00	0.013	-1.43E-03	0.0	-0.0		43355
2	49.40	20.79	0.014	-1.44E-03	3.6	0.5		43355
3	49.10	38.48	0.014	-1.45E-03	12.5	2.8		43355
4	48.65	34.83	0.015	-1.52E-03	29.0	11.6		43355
5	48.20	22.51	0.016	-1.73E-03	41.9	28.3	136.2	43355
		22.51	0.016	-1.73E-03	-94.3	28.3		
6	47.90	26.75	0.016	-1.83E-03	-86.9	0.7		43355
7	47.50	32.35	0.017	-1.69E-03	-75.1	-32.3		43355
		31.86	0.017	-1.69E-03	-75.1	-32.3		
8	47.00	38.85	0.018	-1.14E-03	-57.4	-66.3		43355
9	46.50	45.71	0.018	-2.65E-04	-36.3	-90.7		43355
10	46.00	52.46	0.018	8.23E-04	-11.7	-103.6		43355
11	45.50	59.12	0.017	1.97E-03	16.2	-103.5		43355
12	45.00	65.71	0.016	3.02E-03	47.4	-86.5		43355
		23.75	0.016	3.02E-03	47.4	-86.5		
13	44.53	26.12	0.014	3.79E-03	59.2	-63.2		43355
14	44.05	29.53	0.012	4.26E-03	72.4	-33.4	25.2	43355
		29.53	0.012	4.26E-03	47.2	-33.4		
15	43.85	32.27	0.012	4.36E-03	53.4	-22.6		43355
16	43.41	34.71	0.010	4.41E-03	68.1	5.6		43355
		-62.31	0.010	4.41E-03	68.1	5.6		
17	43.00	-67.24	0.008	4.23E-03	41.5	29.4		43355
18	42.50	-71.28	0.006	3.78E-03	6.9	46.6		43355
19	42.00	-50.16	0.004	3.28E-03	-23.4	41.5		43355
20	41.50	-15.40	0.002	2.89E-03	-39.8	27.3		43355
21	41.13	38.81	0.001	2.73E-03	-35.4	11.0		43355
22	40.75	150.24	0.000	2.69E-03	0.0	0.0		---
At elev. 48.20		Strut force =		136.2 kN/strut =		136.2 kN/m run		
At elev. 44.05		Strut force =		25.2 kN/strut =		25.2 kN/m run		

(continued)

Stage No.10 Change EI of wall to 43355 kN.m2/m run
 Yield moment not defined
 Allow wall to relax with new modulus value

Node no.	Y coord	LEFT side					Total earth pressure	Coeff. of subgrade reaction
		Water press.	Vertic -al	Active limit	Passive limit	Earth pressure		
		kN/m2	kN/m2	kN/m2	kN/m2	kN/m2	kN/m2	kN/m3
1	49.75	0.00	0.00	0.00	0.00	0.00	0.00	6486
2	49.40	0.00	7.81	3.20	20.79	20.79	20.79p	6486
3	49.10	2.94	13.34	5.47	35.54	35.54	38.48p	6486
4	48.65	7.36	20.45	8.39	54.48	27.48	34.83	6486
5	48.20	11.77	26.06	10.69	69.43	10.74	22.51	6486
6	47.90	14.71	29.35	12.04	78.19	12.04	26.75a	3047
7	47.50	18.64	33.42	13.71	89.04	13.71	32.35a	3047
		18.64	33.42	13.22	93.19	13.22	31.86a	8781
8	47.00	23.54	38.68	15.30	107.83	15.30	38.85a	8781
9	46.50	28.45	43.63	17.26	121.63	17.26	45.71a	8781
10	46.00	33.35	48.30	19.11	134.65	19.11	52.46a	8781
11	45.50	38.26	52.73	20.86	147.02	20.86	59.12a	8781
12	45.00	43.16	56.98	22.54	158.86	22.54	65.71a	8781
		Total>	100.15	23.75m	185.51	23.75	23.75a	17177
13	44.53	Total>	109.19	26.12m	198.61	26.12	26.12a	17993
14	44.05	Total>	118.16	28.50m	211.64	29.53	29.53	18809
15	43.85	Total>	121.92	29.50m	217.10	32.27	32.27	22606
16	43.41	Total>	130.17	31.70m	229.12	37.96	37.96	23498
17	43.00	Total>	137.86	33.75m	240.30	42.37	42.37	24330
18	42.50	Total>	147.24	36.67	253.95	51.23	51.23	25343
19	42.00	Total>	156.64	41.65	267.62	87.09	87.09	26357
20	41.50	Total>	166.06	46.65	281.31	120.48	120.48	27371
21	41.13	Total>	173.16	50.43	291.61	144.83	144.83	33091
22	40.75	Total>	180.27	54.22	301.92	187.25	187.25	180878

Node no.	Y coord	RIGHT side					Total earth pressure	Coeff. of subgrade reaction
		Water press.	Vertic -al	Active limit	Passive limit	Earth pressure		
		kN/m2	kN/m2	kN/m2	kN/m2	kN/m2	kN/m2	kN/m3
1	49.75	0.00	0.00	0.00	0.00	0.00	0.00	0.0
2	49.40	0.00	0.00	0.00	0.00	0.00	0.00	0.0
3	49.10	0.00	0.00	0.00	0.00	0.00	0.00	0.0
4	48.65	0.00	0.00	0.00	0.00	0.00	0.00	0.0
5	48.20	0.00	0.00	0.00	0.00	0.00	0.00	0.0
6	47.90	0.00	0.00	0.00	0.00	0.00	0.00	0.0
7	47.50	0.00	0.00	0.00	0.00	0.00	0.00	0.0
8	47.00	0.00	0.00	0.00	0.00	0.00	0.00	0.0
9	46.50	0.00	0.00	0.00	0.00	0.00	0.00	0.0
10	46.00	0.00	0.00	0.00	0.00	0.00	0.00	0.0
11	45.50	0.00	0.00	0.00	0.00	0.00	0.00	0.0
12	45.00	0.00	0.00	0.00	0.00	0.00	0.00	0.0
13	44.53	0.00	0.00	0.00	0.00	0.00	0.00	0.0
14	44.05	0.00	0.00	0.00	0.00	0.00	0.00	0.0
15	43.85	0.00	0.00	0.00	0.00	0.00	0.00	0.0
		0.00	0.00	0.00	0.00	0.00	0.00	3646
16	43.41	0.00	7.92	3.25	21.10	3.25	3.25a	3646
		Total>	7.92	2.20m	106.85	100.27	100.27	23498
17	43.00	Total>	16.12	4.25m	118.55	109.61	109.61	24330
18	42.50	Total>	26.12	6.75m	132.82	122.51	122.51	25343
19	42.00	Total>	36.12	9.25m	147.09	137.25	137.25	26357
20	41.50	Total>	46.12	11.75m	161.36	135.88	135.88	27371

Run ID. Hampstead_Wall_3_450mm_rev_01_ULS2
 Hampstead - 24-26 Redington Gardens
 Wall 3, Secant-ULS2, 450 dia @ 650 - run 01

| Sheet No.
 | Date: 1-10-2018
 | Checked :

(continued)

Stage No.10 Change EI of wall to 43355 kN.m2/m run
 Yield moment not defined
 Allow wall to relax with new modulus value

Node no.	Y coord	----- RIGHT side -----						Total earth pressure	Coeff. of subgrade reaction
		Water press.	Vertic -al	Effective Active limit	Effective Passive limit	Earth pressure	Earth pressure		
		kN/m2	kN/m2	kN/m2	kN/m2	kN/m2	kN/m2	kN/m3	
21	41.13	Total>	53.63	13.62m	172.07	106.01	106.01	33091	
22	40.75	Total>	61.13	15.50m	182.77	37.01	37.01	180878	

Note: 3.25a Soil pressure at active limit
 38.48p Soil pressure at passive limit

Units: kN,m

Stage No.10 Change EI of wall to 43355kN.m²/m run

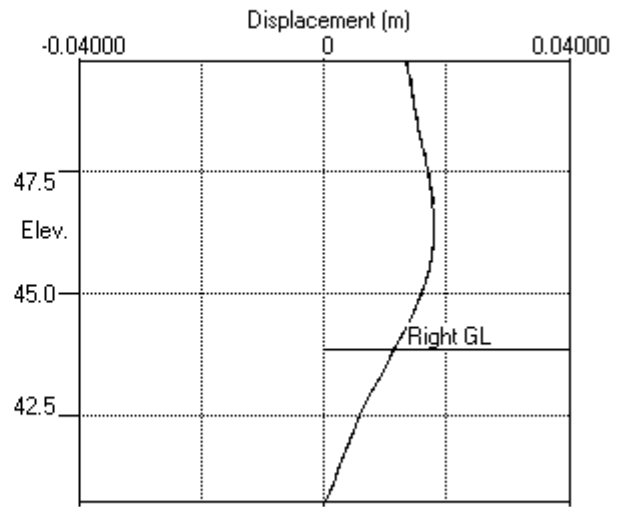
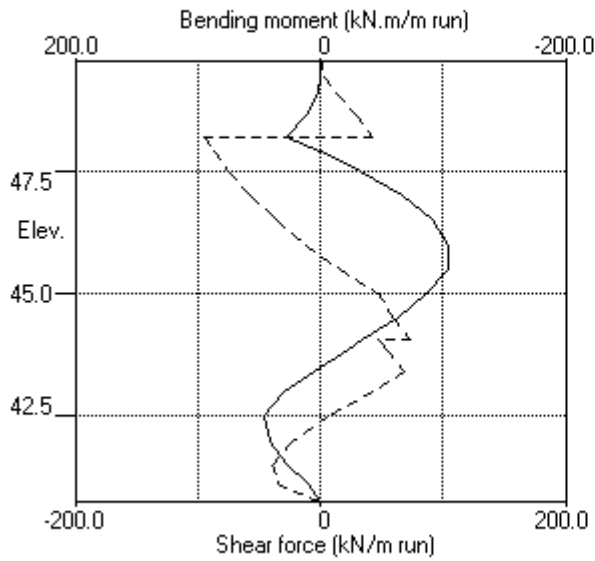

Stage No.10 Change EI of wall to 43355kN.m²/m run

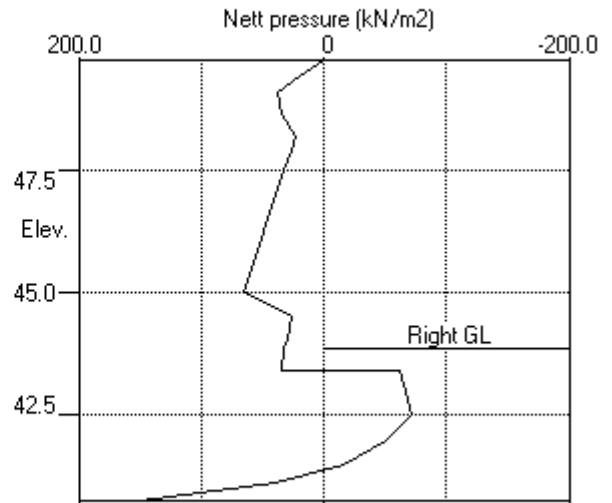
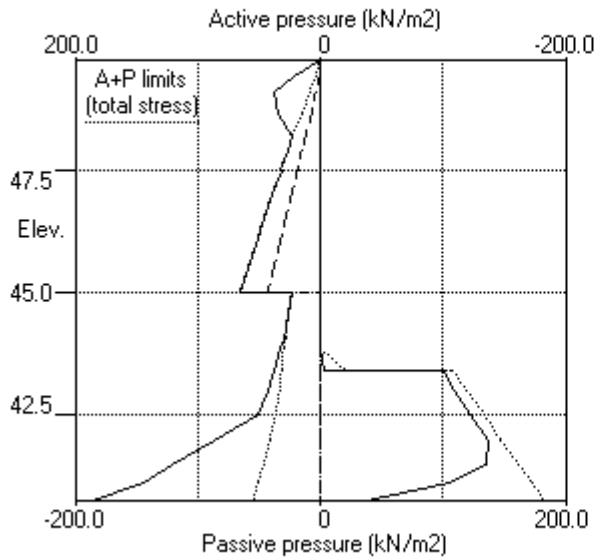

PILEDESIGNS LTD
 Program: WALLAP Version 6.06 Revision A51.B69.R54
 Licensed from GEOSOLVE
 Data filename/Run ID: Hampstead_Wall_3_450mm_rev_01_ULS2
 Hampstead - 24-26 Redington Gardens
 Wall 3, Secant-ULS2, 450 dia @ 650 - run 01

Sheet No.
 Job No. 21495
 Made by : DBS
 Date: 1-10-2018
 Checked :

Units: kN,m

Stage No. 11 Change properties of soil type 3 to soil type 4
 Ko pressures will not be reset

STABILITY ANALYSIS of Fully Embedded Wall according to Strength Factor method
 Factor of safety on soil strength

		Overall						
		FoS for toe	Toe elev. for					
		elev. = 40.75	FoS = 1.000					
Stage No.	--- G.L. --- Act. Pass.	Strut Elev.	Factor of Safety	Moment of equilib. at elev.	Toe elev.	Wall Penetr-ation	Direction of failure	
11	49.75 43.85		More than one strut. No FoS calc.					

** FLOW Warning - Weak strata at or below toe of wall:
 Active limit > Passive limit
 125.42kN/m2 (left) > 121.57kN/m2 (right) at elev. 40.75
 [40.56+84.86(u)] [99.50+22.07(u)]
 The above pressures include water pressure.

Failure and flow of soil BELOW the toe of the wall may occur if the wall is not toed in to a firm stratum. This may occur even when acceptable factors of safety and displacements have been calculated.

BENDING MOMENT and DISPLACEMENT ANALYSIS of Fully Embedded Wall

Analysis options

Length of wall perpendicular to section = 50.00m
 Subgrade reaction model - Boussinesq Influence coefficients
 Soil deformations are elastic until the active or passive limit is reached
 Open Tension Crack analysis - No

Rigid boundaries: Left side 50.00 from wall
 Right side 50.00 from wall

Limit State: ULS DA1 Combination 2

Node no.	Y coord	Nett pressure kN/m2	Wall disp. m	Wall rotation rad.	Shear force kN/m	Bending moment kN.m/m	Strut forces kN/m	EI of wall kN.m2/m
1	49.75	0.00	0.015	-2.26E-04	0.0	-0.0		43355
2	49.40	10.96	0.015	-2.28E-04	1.9	0.5		43355
3	49.10	31.11	0.015	-2.36E-04	8.2	1.8		43355
4	48.65	31.19	0.015	-2.87E-04	22.2	8.0		43355
5	48.20	22.60	0.016	-4.39E-04	34.4	21.3	110.6	43355
		22.60	0.016	-4.39E-04	-76.3	21.3		
6	47.90	28.03	0.016	-5.12E-04	-68.7	-0.9		43355
7	47.50	35.22	0.016	-3.92E-04	-56.0	-26.5		43355
		40.14	0.016	-3.92E-04	-56.0	-26.5		
8	47.00	52.56	0.016	3.29E-05	-32.9	-50.0		43355
9	46.50	64.01	0.016	6.45E-04	-3.7	-60.4		43355
10	46.00	73.80	0.015	1.27E-03	30.7	-54.7		43355
11	45.50	81.00	0.015	1.72E-03	69.4	-30.6		43355
12	45.00	84.45	0.014	1.76E-03	110.8	15.7		43355
		67.39	0.014	1.76E-03	110.8	15.7		
13	44.53	73.91	0.013	1.22E-03	144.4	74.3		43355
14	44.05	80.40	0.013	-6.39E-05	181.0	149.9	320.9	43355
		80.40	0.013	-6.39E-05	-139.9	149.9		
15	43.85	83.13	0.013	-7.20E-04	-123.5	124.4		43355
16	43.41	70.45	0.013	-1.79E-03	-89.8	79.6		43355
		68.94	0.013	-1.79E-03	-89.8	79.6		

(continued)

Stage No.11 Change properties of soil type 3 to soil type 4
 Ko pressures will not be reset

Node no.	Y coord	----- RIGHT side -----						Total earth pressure kN/m2	Coeff. of subgrade reaction kN/m3
		Water press. kN/m2	Vertic -al kN/m2	Effective Active limit kN/m2	Effective Passive limit kN/m2	Earth pressure kN/m2	Effective stresses -----		
12	45.00	0.00	0.00	0.00	0.00	0.00	0.00	0.0	
13	44.53	0.00	0.00	0.00	0.00	0.00	0.00	0.0	
14	44.05	0.00	0.00	0.00	0.00	0.00	0.00	0.0	
15	43.85	0.00	0.00	0.00	0.00	0.00	0.00	0.0	
		0.00	0.00	0.00	0.00	0.00	0.00	4049	
16	43.41	0.00	7.92	3.25	21.10	18.67	18.67	4049	
		0.00	7.92	3.37	20.18	20.18	20.18p	13917	
17	43.00	0.00	16.12	6.85	41.06	41.06	41.06p	14409	
18	42.50	4.90	21.22	9.02	54.05	54.05	58.95p	15009	
19	42.00	9.81	26.31	11.19	67.03	67.03	76.84p	15610	
20	41.50	14.71	31.41	13.35	80.01	80.01	94.73p	16210	
21	41.13	18.39	35.23	14.98	89.76	89.76	108.15p	16660	
22	40.75	22.07	39.06	16.60	99.50	99.50	121.57p	17111	

Note: 125.42a Soil pressure at active limit
 121.57p Soil pressure at passive limit

Units: kN,m

Stage No.11 Change soil type 3 to soil type 4

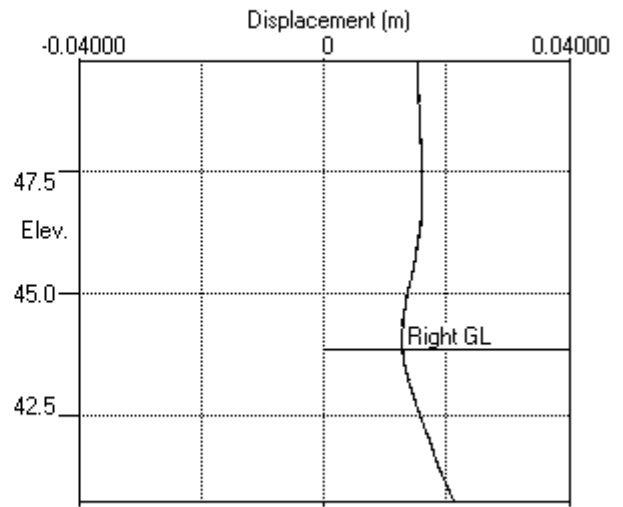
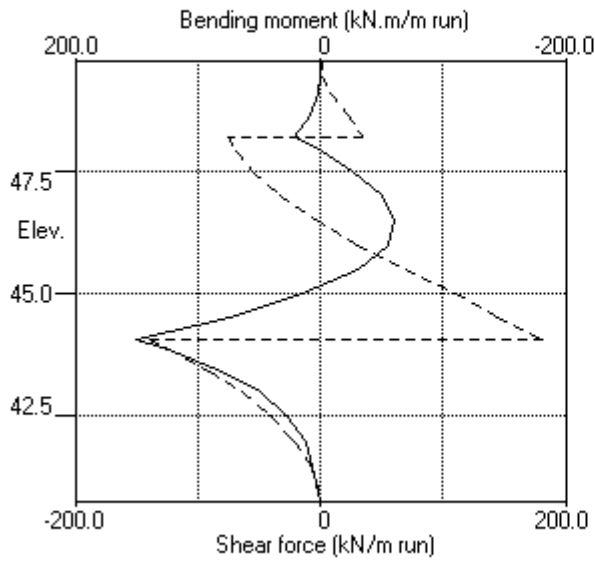

Stage No.11 Change soil type 3 to soil type 4

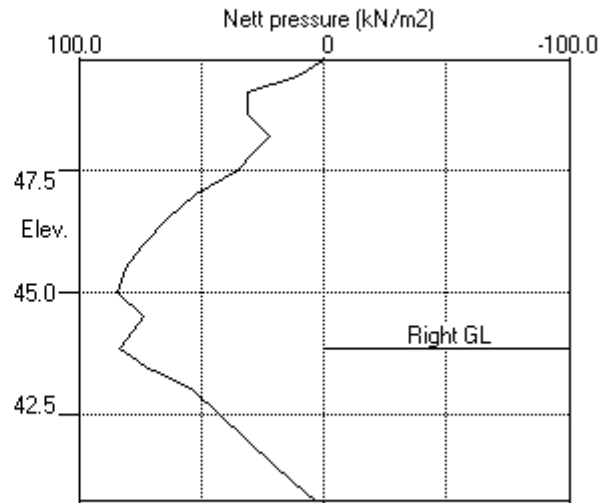
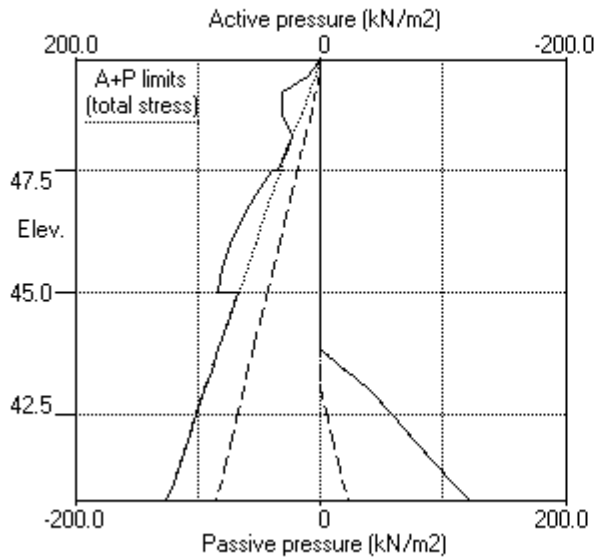

PILEDESIGNS LTD
 Program: WALLAP Version 6.06 Revision A51.B69.R54
 Licensed from GEOSOLVE
 Data filename/Run ID: Hampstead_Wall_3_450mm_rev_01_ULS2
 Hampstead - 24-26 Redington Gardens
 Wall 3, Secant-ULS2, 450 dia @ 650 - run 01

Sheet No.
 Job No. 21495
 Made by : DBS
 Date: 1-10-2018
 Checked :

Units: kN,m

Summary of results

LIMIT STATE PARAMETERS

Limit State: ULS DA1 Combination 2
 Water pressures : Worst Credible
 Partial factor on C' = 1.250
 Partial factor on Phi' = 1.250
 Partial factor on Cu = 1.400
 Partial factor on Soil Modulus = 1.000
 Partial factor on Permanent Unfavourable loads = 1.000
 Partial factor on Permanent Favourable loads = 1.000
 Partial factor on Variable Unfavourable loads = 1.300

STABILITY ANALYSIS of Fully Embedded Wall according to Strength Factor method

Factor of safety on soil strength

			Overall					
			FoS for toe		Toe elev. for			
			elev. = 40.75		FoS = 1.000			

Stage No.	--- G.L. Act.	--- Pass.	Strut Elev.	Factor of Safety	Moment at elev.	Toe elev.	Wall Penetr-ation	Direction of failure
1	49.75	49.75	Cant.	Conditions not suitable for FoS calc.				
2	49.75	49.75	Cant.	Conditions not suitable for FoS calc.				
3	49.75	49.75	Cant.	Conditions not suitable for FoS calc.				
4	49.75	47.90	Cant.	1.642	41.78	43.16	4.74	L to R
5	49.75	47.90	No analysis at this stage					
6	49.75	47.90	48.20	Conditions not suitable for FoS calc.				
7	49.75	43.41	48.20	1.380	n/a	42.39	1.02	L to R
8	49.75	43.85	48.20	1.446	n/a	42.50	1.35	L to R
9	49.75	43.85	No analysis at this stage					
10	49.75	43.85	More than one strut. No FoS calc.					
11	49.75	43.85	More than one strut. No FoS calc. **FLOW Warning					
12	49.75	43.85	No analysis at this stage					
13	49.75	43.85	More than one strut. No FoS calc.					

Legend: **FLOW Warning

Failure and flow of soil BELOW the toe of the wall may occur if the wall is not toed in to a firm stratum. It may occur even when acceptable factors of safety and displacements have been calculated. See individual stage results for details.

Units: kN,m

Summary of results

BENDING MOMENT and DISPLACEMENT ANALYSIS of Fully Embedded Wall

Analysis options

Length of wall perpendicular to section = 50.00m
 Subgrade reaction model - Boussinesq Influence coefficients
 Soil deformations are elastic until the active or passive limit is reached
 Open Tension Crack analysis - No

Rigid boundaries: Left side 50.00 from wall
 Right side 50.00 from wall

Limit State: ULS DA1 Combination 2

Bending moment, shear force and displacement envelopes

Node no.	Y coord	Displacement		Bending moment		Shear force	
		maximum m	minimum m	maximum kN.m/m	minimum kN.m/m	maximum kN/m	minimum kN/m
1	49.75	0.023	0.000	0.0	-0.0	0.0	0.0
2	49.40	0.022	0.000	0.5	-0.0	3.6	-1.0
3	49.10	0.020	0.000	2.8	-0.5	12.5	-2.4
4	48.65	0.018	0.000	11.6	-1.8	29.0	-2.7
5	48.20	0.016	0.000	28.3	-2.7	41.9	-100.6
6	47.90	0.016	0.000	14.0	-2.8	23.7	-93.2
7	47.50	0.017	0.000	25.3	-35.9	31.7	-81.4
8	47.00	0.018	0.000	42.0	-72.4	34.9	-63.7
9	46.50	0.018	0.000	59.0	-99.2	32.7	-42.5
10	46.00	0.018	0.000	73.6	-114.6	30.7	-17.9
11	45.50	0.017	0.000	83.0	-116.8	69.4	0.0
12	45.00	0.016	0.000	86.8	-102.1	110.8	-3.8
13	44.53	0.014	0.000	77.9	-80.9	144.4	-25.9
14	44.05	0.013	0.000	149.9	-53.1	181.0	-139.9
15	43.85	0.013	0.000	124.4	-39.0	73.6	-123.5
16	43.41	0.013	0.000	81.8	-4.6	87.2	-89.8
17	43.00	0.014	0.000	57.6	0.0	56.6	-64.6
18	42.50	0.016	0.000	47.2	0.0	15.8	-41.3
19	42.00	0.017	0.000	44.2	0.0	0.0	-28.3
20	41.50	0.019	0.000	29.7	0.0	0.0	-42.2
21	41.13	0.020	0.000	12.3	0.0	0.0	-39.6
22	40.75	0.021	0.000	0.0	-0.0	0.0	-0.0

Maximum and minimum bending moment and shear force at each stage

Stage no.	Bending moment				Shear force			
	maximum kN.m/m	elev.	minimum kN.m/m	elev.	maximum kN/m	elev.	minimum kN/m	elev.
1	2.4	43.85	-2.2	46.50	3.5	45.00	-1.1	48.65
2	2.2	43.41	-3.3	46.50	4.6	45.00	-1.4	48.20
3	5.6	44.05	-2.8	47.90	5.6	45.00	-2.7	48.65
4	86.8	45.00	-0.0	49.75	34.9	47.00	-35.5	43.85
5	No calculation at this stage							
6	81.6	45.00	-0.0	49.75	29.2	47.00	-32.9	43.85
7	46.1	42.50	-115.9	45.50	85.5	43.41	-100.2	48.20
8	47.2	42.50	-116.8	45.50	87.2	43.41	-100.6	48.20
9	No calculation at this stage							
10	46.6	42.50	-103.6	46.00	72.4	44.05	-94.3	48.20
11	149.9	44.05	-60.4	46.50	181.0	44.05	-139.9	44.05
12	No calculation at this stage							
13	129.4	44.05	-64.3	46.50	173.2	44.05	-97.0	44.05

Summary of results (continued)

Maximum and minimum displacement at each stage

Stage no.	Displacement maximum	elev.	Displacement minimum	elev.	Stage description
	m		m		
1	0.001	49.75	0.000	49.75	Apply surcharge no.1 at elev. 49.75
2	0.001	49.75	0.000	49.75	Apply surcharge no.2 at elev. 49.10
3	0.002	49.75	0.000	49.75	Apply water pressure profile no.1
4	0.023	49.75	0.000	49.75	Excav. to elev. 47.90 on RIGHT side
5	No calculation at this stage				Install strut no.1 at elev. 48.20
6	0.023	49.75	0.000	49.75	Apply water pressure profile no.2
7	0.017	46.50	0.000	49.75	Excav. to elev. 43.41 on RIGHT side
8	0.017	46.50	0.000	49.75	Fill to elev. 43.85 on RIGHT side
9	No calculation at this stage				Install strut no.2 at elev. 44.05
10	0.018	46.50	0.000	49.75	Change EI of wall to 43355kN.m ² /m run
11	0.021	40.75	0.000	49.75	Change soil type 3 to soil type 4
12	No calculation at this stage				Apply surcharge no.3 at elev. 43.85
13	0.019	40.75	0.000	49.75	Apply water pressure profile no.3

Strut forces at each stage (horizontal components)

Stage no.	Strut no. 1 at elev. 48.20		Strut no. 2 at elev. 44.05	
	kN/m run	kN/strut	kN/m run	kN/strut
6	7.46	7.46	---	---
7	141.62	141.62	---	---
8	141.97	141.97	---	---
10	136.24	136.24	25.24	25.24
11	110.62	110.62	320.91	320.91
13	113.89	113.89	270.20	270.20

Units: kN,m

Bending moment, shear force, displacement envelopes

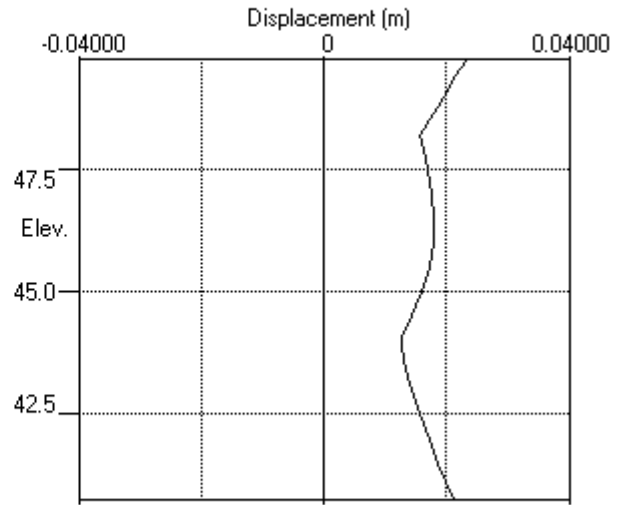
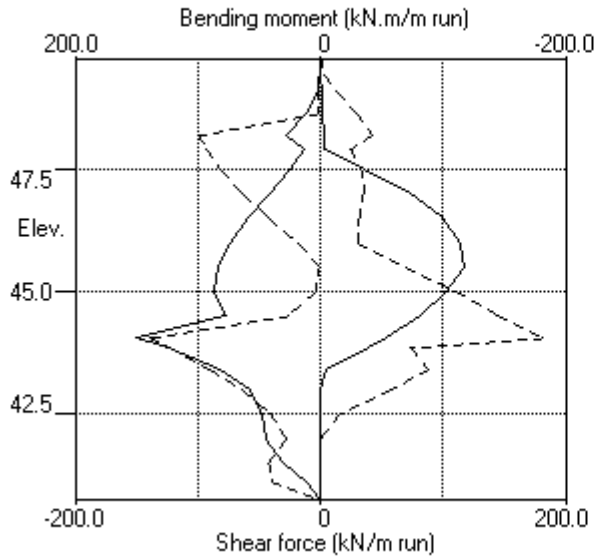



WALLAP

3-SLS

PILEDESIGNS LTD
 Program: WALLAP Version 6.06 Revision A51.B69.R54
 Licensed from GEOSOLVE
 Data filename/Run ID: Hampstead_Wall_3_450mm_rev_01_SLS
 Hampstead - 24-26 Redington Gardens
 Wall 3, Secant-SLS, 450 dia @ 650 - run 01

Sheet No.
 Job No. 21495
 Made by : DBS
 Date: 1-10-2018
 Checked :

Units: kN,m

INPUT DATA

SOIL PROFILE

Stratum no.	Elevation of top of stratum	Soil types	
		Left side	Right side
1	49.75	1 Made Ground dr	1 Made Ground dr
2	47.50	2 Claygate Clay dr	2 Claygate Clay dr
3	45.00	3 London Clay und	3 London Clay und

SOIL PROPERTIES

No. Description	Bulk density kN/m3	Young's Modulus Eh, kN/m2	At rest coeff. Ko	Consol state. NC/OC	Active limit Ka	Passive limit Kp	Cohesion kN/m2
(Datum elev.)		(dEh/dy)	(dKo/dy)	(Nu)	(Kac)	(Kpc)	(dc/dy)
1 Made Ground dr	18.00	10000	0.530	OC (0.250)	0.337 (0.000)	3.442 (0.000)	
2 Claygate Clay dr	19.00	30000	1.000	NC (0.200)	0.323 (1.330)	3.647 (5.195)	0.0d
3 London Cl.. (45.00)	20.00	40000 (4000)	1.000	OC (0.490)	1.000 (2.476)	1.000 (2.390)	50.00u (5.000)
4 London Cl.. (45.00)	20.00	30800 (3080)	1.000	OC (0.200)	0.351 (1.391)	3.253 (4.831)	0.0d

Additional soil parameters associated with Ka and Kp

No. Description	--- parameters for Ka ---			--- parameters for Kp ---		
	Soil friction angle	Wall adhesion coeff.	Back-fill angle	Soil friction angle	Wall adhesion coeff.	Back-fill angle
1 Made Ground dr	26.00	0.670	0.00	26.00	0.500	0.00
2 Claygate Clay dr	27.00	0.670	0.00	27.00	0.500	0.00
3 London Clay und	0.00	0.670	0.00	0.00	0.500	0.00
4 London Clay dr	25.00	0.670	0.00	25.00	0.500	0.00

GROUND WATER CONDITIONS

Density of water = 9.810 kN/m3

	Left side	Right side
Initial water table elevation	49.40	49.40

Automatic water pressure balancing at toe of wall : No

Water profile no.	Left side				Right side			
	Point no.	Elev. m	Piezo elev. m	Water press. kN/m2	Point no.	Elev. m	Piezo elev. m	Water press. kN/m2
1	1	49.40	49.40	0.0	1	47.50	47.50	0.0 MC+WC
2	1	49.40	49.40	0.0	1	43.00	43.00	0.0 MC+WC
3	1	49.40	49.40	0.0	1	43.85	43.85	0.0 MC+WC
					2	43.85	49.40	54.4

WALL PROPERTIES

Type of structure = Fully Embedded Wall
 Elevation of toe of wall = 40.75
 Maximum finite element length = 0.50 m
 Youngs modulus of wall E = 1.9600E+07 kN/m2
 Moment of inertia of wall I = 3.0968E-03 m4/m run
 E.I = 60696 kN.m2/m run
 Yield Moment of wall = Not defined

STRUTS and ANCHORS

Strut/ anchor no.	Elev.	Strut spacing m	X-section area of strut sq.m	Youngs modulus kN/m ²	Free length m	Inclin -ation (degs)	Pre- stress /strut kN	Tension allowed
1	48.20	1.00	0.300000	1.400E+07	5.00	0.00	0	No
2	44.05	1.00	0.300000	1.400E+07	5.00	0.00	0	No

SURCHARGE LOADS

Surch -arge no.	Elev.	Distance from wall	Length parallel to wall	Width perpend. to wall	Surcharge ----- kN/m ² ----- Near edge Far edge		Equiv. soil type	Partial factor/ Category
1	49.75	0.50(L)	10.00	2.75	13.00	=	N/A	1.00 Var
2	49.10	3.25(L)	10.00	0.50	90.00	=	N/A	1.00 P/U
3	43.85	-0.00(R)	10.00	10.00	55.00	=	N/A	1.00 P/F

Note: L = Left side, R = Right side

Limit State Categories P/U = Permanent Unfavourable
P/F = Permanent Favourable
Var = Variable (unfavourable)

CONSTRUCTION STAGES

Construction stage no.	Stage description
1	Apply surcharge no.1 at elevation 49.75
2	Apply surcharge no.2 at elevation 49.10
3	Apply water pressure profile no.1 (Mod. Conserv.)
4	Excavate to elevation 47.90 on RIGHT side
5	Install strut or anchor no.1 at elevation 48.20
6	Apply water pressure profile no.2 (Mod. Conserv.)
7	Excavate to elevation 43.85 on RIGHT side
8	Install strut or anchor no.2 at elevation 44.05
9	Change EI of wall to 43355 kN.m ² /m run Yield moment not defined Allow wall to relax with new modulus value
10	Change properties of soil type 3 to soil type 4 Ko pressures will not be reset
11	Apply surcharge no.3 at elevation 43.85 No analysis at this stage
12	Apply water pressure profile no.3 (Mod. Conserv.)

FACTORS OF SAFETY and ANALYSIS OPTIONS

Limit State options: Serviceability Limit State
All loads and soil strengths are unfactored

Stability analysis:

Method of analysis - Strength Factor method
Factor on soil strength for calculating wall depth = 1.50

Parameters for undrained strata:

Minimum equivalent fluid density = 5.00 kN/m³
Maximum depth of water filled tension crack = 0.00 m

Bending moment and displacement calculation:

Method - Subgrade reaction model using Influence Coefficients
Open Tension Crack analysis? - No
Non-linear Modulus Parameter (L) = 9.000 m

Boundary conditions:

Length of wall (normal to plane of analysis) = 50.00 m

Width of excavation on Left side of wall = 50.00 m
Width of excavation on Right side of wall = 50.00 m

Distance to rigid boundary on Left side = 50.00 m
Distance to rigid boundary on Right side = 50.00 m

OUTPUT OPTIONS

Stage no.	Stage description	Output options		
		Displacement	Active,	Graph.
		Bending mom.	Passive	output
		Shear force	pressures	
1	Apply surcharge no.1 at elev. 49.75	No	No	No
2	Apply surcharge no.2 at elev. 49.10	Yes	Yes	Yes
3	Apply water pressure profile no.1	Yes	Yes	Yes
4	Excav. to elev. 47.90 on RIGHT side	Yes	Yes	Yes
5	Install strut no.1 at elev. 48.20	Yes	Yes	Yes
6	Apply water pressure profile no.2	Yes	Yes	Yes
7	Excav. to elev. 43.85 on RIGHT side	Yes	Yes	Yes
8	Install strut no.2 at elev. 44.05	Yes	Yes	Yes
9	Change EI of wall to 43355kN.m ² /m run	No	No	No
10	Change soil type 3 to soil type 4	No	No	No
11	Apply surcharge no.3 at elev. 43.85	No	No	No
12	Apply water pressure profile no.3	No	No	No
*	Summary output	Yes	-	Yes

Program WALLAP - Copyright (C) 2017 by DL Borin, distributed by GEOSOLVE
 150 St. Alphonsus Road, London SW4 7BW, UK www.geosolve.co.uk

Units: kN,m

Stage No.12 Apply water pressure profile no.3 (Mod. Conserv.)

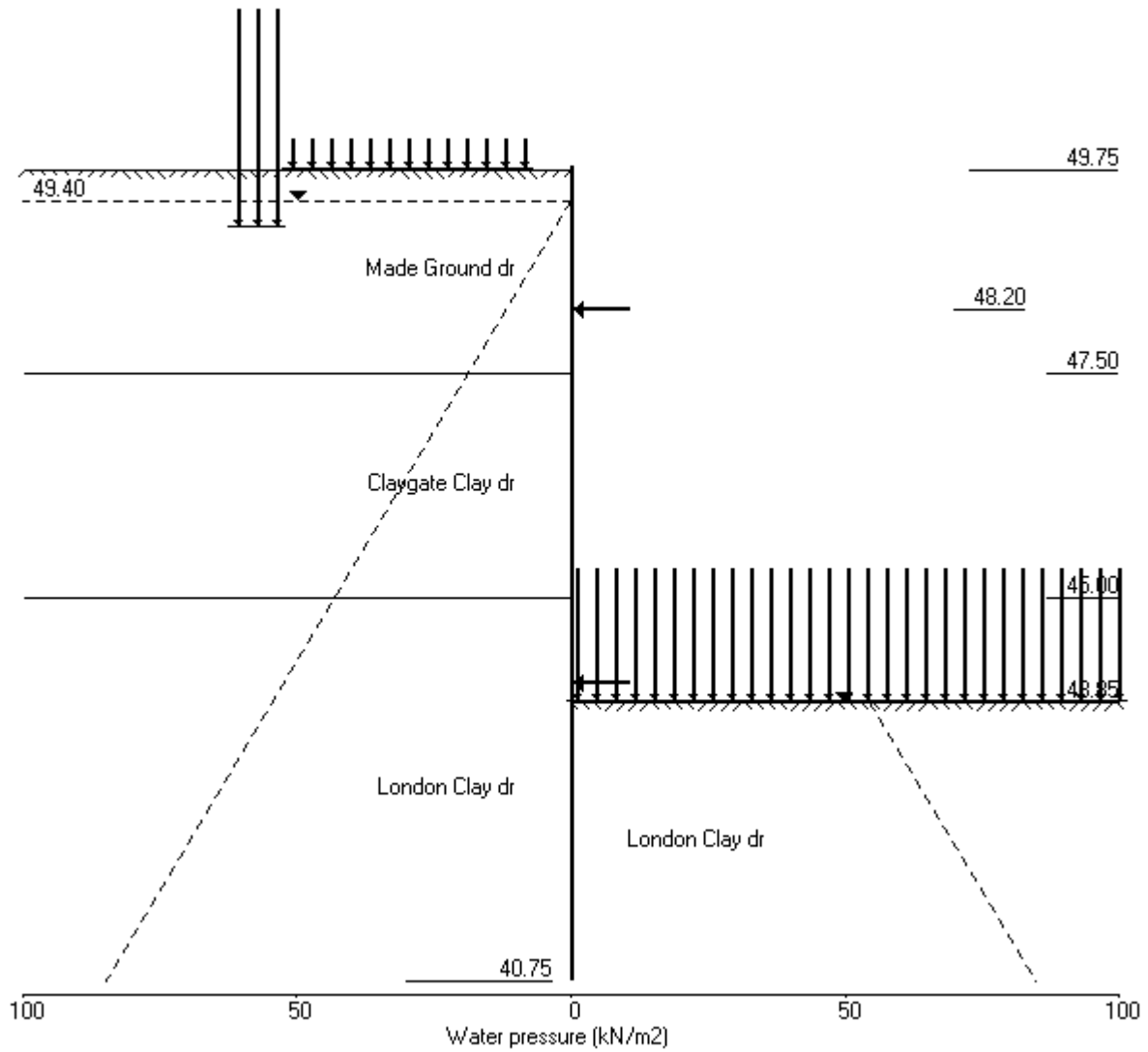

PILEDESIGNS LTD
 Program: WALLAP Version 6.06 Revision A51.B69.R54
 Licensed from GEOSOLVE
 Data filename/Run ID: Hampstead_Wall_3_450mm_rev_01_SLS
 Hampstead - 24-26 Redington Gardens
 Wall 3, Secant-SLS, 450 dia @ 650 - run 01

Sheet No.
 Job No. 21495
 Made by : DBS
 Date: 1-10-2018
 Checked :

Units: kN,m

Stage No. 4 Excavate to elevation 47.90 on RIGHT side

STABILITY ANALYSIS of Fully Embedded Wall according to Strength Factor method
 Factor of safety on soil strength

Stage No.	--- G.L. --- Act.	--- Pass. ---	Strut Elev.	FoS for toe elev. =	Moment of equil. at elev.	Toe elev. for FoS =	Wall Penetr-ation	Direction of failure
4	49.75	47.90	Cant.	2.256	41.80	42.60	5.30	L to R

BENDING MOMENT and DISPLACEMENT ANALYSIS of Fully Embedded Wall

Analysis options

Length of wall perpendicular to section = 50.00m
 Subgrade reaction model - Boussinesq Influence coefficients
 Soil deformations are elastic until the active or passive limit is reached
 Open Tension Crack analysis - No

Rigid boundaries: Left side 50.00 from wall
 Right side 50.00 from wall

Limit State: Serviceability Limit State

Calculated Bending Moments and Strut Forces are to be multiplied by a factor of 1.35 to obtain values for structural design. See summary for factored values.

Node no.	Y coord	Nett pressure kN/m2	Wall disp. m	Wall rotation rad.	Shear force kN/m	Bending moment kN.m/m	Strut forces kN/m	EI of wall kN.m2/m
1	49.75	0.00	0.011	2.60E-03	0.0	0.0		60696
2	49.40	2.51	0.010	2.60E-03	0.4	0.1		60696
3	49.10	7.08	0.010	2.59E-03	1.9	0.5		60696
4	48.65	13.62	0.008	2.58E-03	6.5	2.2		60696
5	48.20	19.79	0.007	2.55E-03	14.1	6.8		60696
6	47.90	23.80	0.006	2.50E-03	20.6	12.0		60696
7	47.50	4.29	0.005	2.39E-03	26.2	21.6		60696
		2.38	0.005	2.39E-03	26.2	21.6		
8	47.00	-12.68	0.004	2.16E-03	23.6	34.3		60696
9	46.50	-27.81	0.003	1.84E-03	13.5	43.8		60696
10	46.00	-28.64	0.003	1.46E-03	-0.6	48.6		60696
11	45.50	-14.30	0.002	1.08E-03	-11.3	44.7		60696
12	45.00	-4.75	0.001	7.46E-04	-16.1	37.2		60696
		-9.25	0.001	7.46E-04	-16.1	37.2		
13	44.53	0.36	0.001	4.88E-04	-18.2	28.5		60696
14	44.05	5.72	0.001	2.99E-04	-16.8	19.9		60696
15	43.85	6.96	0.001	2.39E-04	-15.5	16.7		60696
16	43.42	8.12	0.001	1.43E-04	-12.3	10.7		60696
17	43.00	7.84	0.001	8.45E-05	-8.9	6.2		60696
18	42.50	6.46	0.001	4.79E-05	-5.3	2.7		60696
19	42.00	4.57	0.001	3.34E-05	-2.6	0.8		60696
20	41.50	2.55	0.001	2.96E-05	-0.8	0.1		60696
21	41.13	1.04	0.001	2.94E-05	-0.1	-0.0		60696
22	40.75	-0.46	0.001	2.94E-05	0.0	-0.0		---

(continued)

Stage No.4 Excavate to elevation 47.90 on RIGHT side

Node no.	Y coord	LEFT side					Total earth pressure kN/m2	Coeff. of subgrade reaction kN/m3
		Water press. kN/m2	Vertic -al kN/m2	Effective Active limit kN/m2	Effective Passive limit kN/m2	Earth pressure kN/m2		
1	49.75	0.00	0.00	0.00	0.00	0.00	0.00	3619
2	49.40	0.00	7.46	2.51	25.67	2.51	2.51a	3619
3	49.10	2.94	12.28	4.14	42.28	4.14	7.08a	3619
4	48.65	7.36	18.61	6.27	64.07	6.27	13.62a	3619
5	48.20	11.77	23.83	8.02	82.01	8.02	19.79a	3619
6	47.90	14.71	26.98	9.08	92.89	9.08	23.80a	3619
7	47.50	18.64	30.99	10.43	106.68	10.43	29.07a	3619
		18.64	30.99	10.00	113.02	10.00	28.64a	10446
8	47.00	23.54	36.27	11.70	132.28	11.70	35.24a	10446
9	46.50	28.45	41.32	13.33	150.68	13.33	41.78a	10446
10	46.00	33.35	46.13	14.88	168.21	23.37	56.72	10446
11	45.50	38.26	50.71	16.36	184.94	34.32	72.58	10446
12	45.00	43.16	55.11	17.78	200.99	43.16	86.32	10446
		Total>	98.28	23.75m	217.77	74.34	74.34	20134
13	44.53	Total>	107.46	26.12m	232.64	87.97	87.97	21091
14	44.05	Total>	116.56	28.50m	247.41	99.70	99.70	22047
15	43.85	Total>	120.38	29.50m	253.62	104.19	104.19	22450
16	43.42	Total>	128.46	31.63m	266.78	113.07	113.07	23305
17	43.00	Total>	136.53	33.75m	279.93	121.30	121.30	24161
18	42.50	Total>	146.02	36.25m	295.39	130.51	130.51	25168
19	42.00	Total>	155.52	38.75m	310.86	139.49	139.49	26175
20	41.50	Total>	165.03	41.25m	326.35	148.42	148.42	27181
21	41.13	Total>	172.19	43.13m	337.99	155.13	155.13	27936
22	40.75	Total>	179.36	45.00m	349.64	161.86	161.86	28691

Node no.	Y coord	RIGHT side					Total earth pressure kN/m2	Coeff. of subgrade reaction kN/m3
		Water press. kN/m2	Vertic -al kN/m2	Effective Active limit kN/m2	Effective Passive limit kN/m2	Earth pressure kN/m2		
1	49.75	0.00	0.00	0.00	0.00	0.00	0.00	0.0
2	49.40	0.00	0.00	0.00	0.00	0.00	0.00	0.0
3	49.10	0.00	0.00	0.00	0.00	0.00	0.00	0.0
4	48.65	0.00	0.00	0.00	0.00	0.00	0.00	0.0
5	48.20	0.00	0.00	0.00	0.00	0.00	0.00	0.0
6	47.90	0.00	0.00	0.00	0.00	0.00	0.00	0.0
		0.00	0.00	0.00	0.00	0.00	0.00	4870
7	47.50	0.00	7.20	2.42	24.78	24.78	24.78p	4870
		0.00	7.20	2.32	26.26	26.26	26.26p	14086
8	47.00	4.90	11.80	3.80	43.02	43.02	47.92p	14086
9	46.50	9.81	16.39	5.29	59.77	59.77	69.58p	14086
10	46.00	14.71	20.99	6.77	76.53	70.65	85.36	14086
11	45.50	19.62	25.58	8.25	93.29	67.27	86.89	14086
12	45.00	24.52	30.18	9.73	110.05	66.54	91.07	14086
		Total>	54.70	14.50m	174.20	83.59	83.59	26628
13	44.53	Total>	64.20	16.88m	189.38	87.60	87.60	27893
14	44.05	Total>	73.71	19.25m	204.56	93.98	93.98	29158
15	43.85	Total>	77.71	20.25m	210.95	97.23	97.23	29691
16	43.42	Total>	86.21	22.38m	224.53	104.95	104.95	30822
17	43.00	Total>	94.71	24.50m	238.11	113.46	113.46	31954
18	42.50	Total>	104.72	27.00m	254.09	124.05	124.05	33286
19	42.00	Total>	114.72	29.50m	270.07	134.92	134.92	34617
20	41.50	Total>	124.73	32.00m	286.05	145.87	145.87	35948
21	41.13	Total>	132.23	33.88m	298.04	154.09	154.09	36947

(continued)

Stage No.4 Excavate to elevation 47.90 on RIGHT side

Node no.	Y coord	----- RIGHT side -----					Total earth pressure kN/m2	Coeff. of subgrade reaction kN/m3
		Water press. kN/m2	Vertic -al kN/m2	Effective Active limit kN/m2	Effective Passive limit kN/m2	Earth pressure kN/m2		
22	40.75	Total>	139.74	35.75m	310.02	162.32	162.32	37945

Note: 41.78a Soil pressure at active limit
 69.58p Soil pressure at passive limit

Units: kN,m

Stage No.4 Excav. to elev. 47.90 on RIGHT side

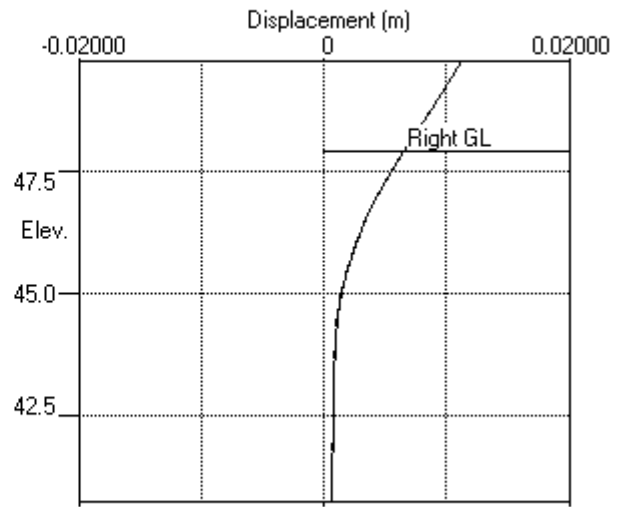
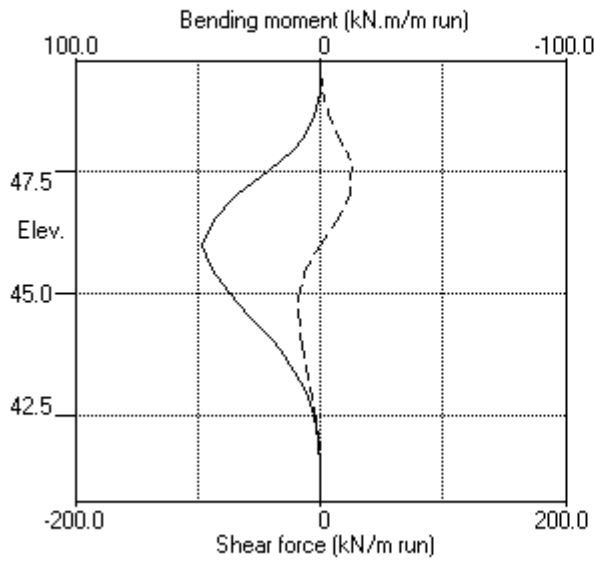

Stage No.4 Excav. to elev. 47.90 on RIGHT side

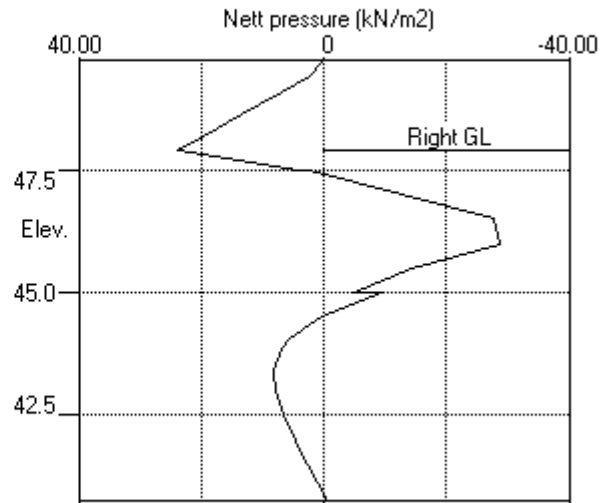
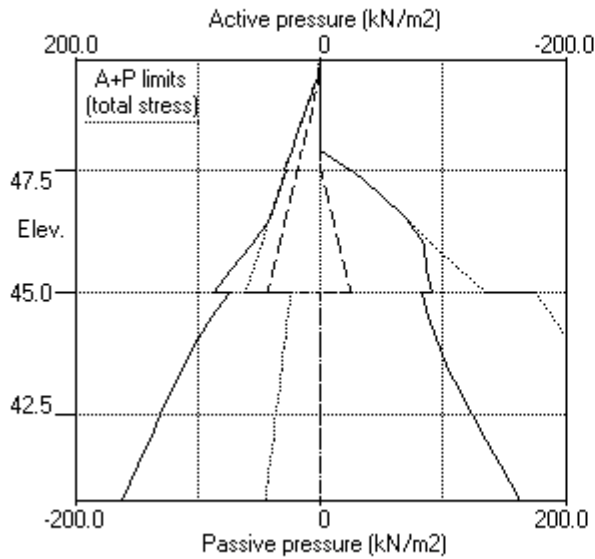

PILEDESIGNS LTD
 Program: WALLAP Version 6.06 Revision A51.B69.R54
 Licensed from GEOSOLVE
 Data filename/Run ID: Hampstead_Wall_3_450mm_rev_01_SLS
 Hampstead - 24-26 Redington Gardens
 Wall 3, Secant-SLS, 450 dia @ 650 - run 01

Sheet No.
 Job No. 21495
 Made by : DBS
 Date: 1-10-2018
 Checked :

Units: kN,m

Stage No. 7 Excavate to elevation 43.85 on RIGHT side

STABILITY ANALYSIS of Fully Embedded Wall according to Strength Factor method
 Factor of safety on soil strength

Stage No.	--- G.L. --- Act.	--- G.L. --- Pass.	Strut Elev.	FoS for toe elev. =	Moment of equil. at elev.	Toe elev. for FoS =	Wall Penetr-ation	Direction of failure
7	49.75	43.85	48.20	40.75	n/a	1.500	1.10	L to R

BENDING MOMENT and DISPLACEMENT ANALYSIS of Fully Embedded Wall

Analysis options

Length of wall perpendicular to section = 50.00m
 Subgrade reaction model - Boussinesq Influence coefficients
 Soil deformations are elastic until the active or passive limit is reached
 Open Tension Crack analysis - No

Rigid boundaries: Left side 50.00 from wall
 Right side 50.00 from wall

Limit State: Serviceability Limit State

Calculated Bending Moments and Strut Forces are to be multiplied by a factor of 1.35 to obtain values for structural design. See summary for factored values.

Node no.	Y coord	Nett pressure kN/m2	Wall disp. m	Wall rotation rad.	Shear force kN/m	Bending moment kN.m/m	Strut forces kN/m	EI of wall kN.m2/m
1	49.75	0.00	0.006	-9.55E-04	0.0	0.0		60696
2	49.40	25.67	0.006	-9.57E-04	4.5	0.6		60696
3	49.10	28.36	0.006	-9.66E-04	12.6	2.8		60696
4	48.65	23.91	0.007	-1.01E-03	24.4	11.6		60696
5	48.20	19.79	0.007	-1.15E-03	34.2	25.2	115.9	60696
		19.79	0.007	-1.15E-03	-81.7	25.2		
6	47.90	23.80	0.008	-1.22E-03	-75.1	1.7		60696
7	47.50	29.07	0.008	-1.14E-03	-64.6	-26.4		60696
		28.64	0.008	-1.14E-03	-64.6	-26.4		
8	47.00	35.24	0.009	-8.06E-04	-48.6	-54.8		60696
9	46.50	41.78	0.009	-2.74E-04	-29.3	-74.5		60696
10	46.00	48.23	0.009	3.70E-04	-6.8	-82.0		60696
11	45.50	54.62	0.009	1.03E-03	18.9	-79.7		60696
12	45.00	60.94	0.008	1.62E-03	47.8	-63.6		60696
		23.75	0.008	1.62E-03	47.8	-63.6		
13	44.53	26.12	0.007	2.02E-03	59.6	-38.6		60696
14	44.05	28.50	0.006	2.20E-03	72.6	-7.5		60696
15	43.85	31.24	0.006	2.20E-03	78.6	8.1		60696
		-102.00	0.006	2.20E-03	78.6	8.1		
16	43.42	-90.26	0.005	2.05E-03	37.7	35.6		60696
17	43.00	-61.14	0.004	1.77E-03	5.5	43.4		60696
18	42.50	-31.33	0.003	1.43E-03	-17.6	38.5		60696
19	42.00	-6.14	0.002	1.17E-03	-26.9	25.8		60696
20	41.50	16.08	0.002	1.01E-03	-24.5	11.6		60696
21	41.13	32.23	0.002	9.72E-04	-15.4	3.5		60696
22	40.75	49.89	0.001	9.61E-04	0.0	-0.0		---

At elev. 48.20 Strut force = 115.9 kN/strut = 115.9 kN/m run

(continued)

Stage No.7 Excavate to elevation 43.85 on RIGHT side

Node no.	Y coord	LEFT side					Total earth pressure kN/m2	Coeff. of subgrade reaction kN/m3
		Water press. kN/m2	Vertic -al kN/m2	Effective Active limit kN/m2	Effective Passive limit kN/m2	Earth pressure kN/m2		
1	49.75	0.00	0.00	0.00	0.00	0.00	6824	
2	49.40	0.00	7.46	2.51	25.67	25.67	6824	
3	49.10	2.94	12.28	4.14	42.28	25.42	6824	
4	48.65	7.36	18.61	6.27	64.07	16.55	6824	
5	48.20	11.77	23.83	8.02	82.01	8.02	2390	
6	47.90	14.71	26.98	9.08	92.89	9.08	2390	
7	47.50	18.64	30.99	10.43	106.68	10.43	2390	
		18.64	30.99	10.00	113.02	10.00	6869	
8	47.00	23.54	36.27	11.70	132.28	11.70	6869	
9	46.50	28.45	41.32	13.33	150.68	13.33	6869	
10	46.00	33.35	46.13	14.88	168.21	14.88	6869	
11	45.50	38.26	50.71	16.36	184.94	16.36	6869	
12	45.00	43.16	55.11	17.78	200.99	17.78	6869	
		Total>	98.28	23.75m	217.77	23.75	13821	
13	44.53	Total>	107.46	26.12m	232.64	26.12	14478	
14	44.05	Total>	116.56	28.50m	247.41	28.50	15134	
15	43.85	Total>	120.38	29.50m	253.62	31.24	15411	
16	43.42	Total>	128.46	31.63m	266.78	50.68	15998	
17	43.00	Total>	136.53	33.75m	279.93	69.40	16585	
18	42.50	Total>	146.02	36.25m	295.39	89.78	17277	
19	42.00	Total>	155.52	38.75m	310.86	108.45	17968	
20	41.50	Total>	165.03	41.25m	326.35	126.06	18659	
21	41.13	Total>	172.19	43.13m	337.99	139.08	19177	
22	40.75	Total>	179.36	45.00m	349.64	152.80	19695	

Node no.	Y coord	RIGHT side					Total earth pressure kN/m2	Coeff. of subgrade reaction kN/m3
		Water press. kN/m2	Vertic -al kN/m2	Effective Active limit kN/m2	Effective Passive limit kN/m2	Earth pressure kN/m2		
1	49.75	0.00	0.00	0.00	0.00	0.00	0.0	
2	49.40	0.00	0.00	0.00	0.00	0.00	0.0	
3	49.10	0.00	0.00	0.00	0.00	0.00	0.0	
4	48.65	0.00	0.00	0.00	0.00	0.00	0.0	
5	48.20	0.00	0.00	0.00	0.00	0.00	0.0	
6	47.90	0.00	0.00	0.00	0.00	0.00	0.0	
7	47.50	0.00	0.00	0.00	0.00	0.00	0.0	
8	47.00	0.00	0.00	0.00	0.00	0.00	0.0	
9	46.50	0.00	0.00	0.00	0.00	0.00	0.0	
10	46.00	0.00	0.00	0.00	0.00	0.00	0.0	
11	45.50	0.00	0.00	0.00	0.00	0.00	0.0	
12	45.00	0.00	0.00	0.00	0.00	0.00	0.0	
13	44.53	0.00	0.00	0.00	0.00	0.00	0.0	
14	44.05	0.00	0.00	0.00	0.00	0.00	0.0	
15	43.85	0.00	0.00	0.00	0.00	0.00	0.0	
		Total>	0.00	0.00	133.24	133.24	28204	
16	43.42	Total>	8.50	2.12m	146.82	140.94	29279	
17	43.00	Total>	17.00	4.25m	160.40	130.54	30354	
18	42.50	Total>	27.00	6.75m	176.37	121.11	31618	
19	42.00	Total>	37.00	9.25m	192.35	114.59	32883	
20	41.50	Total>	47.00	11.75m	208.33	109.97	34148	
21	41.13	Total>	54.51	13.62m	220.31	106.85	35096	
22	40.75	Total>	62.01	15.50m	232.29	102.91	36045	

Run ID. Hampstead_Wall_3_450mm_rev_01_SLS
Hampstead - 24-26 Redington Gardens
Wall 3, Secant-SLS, 450 dia @ 650 - run 01

| Sheet No.
| Date: 1-10-2018
| Checked :

(continued)

Stage No.7 Excavate to elevation 43.85 on RIGHT side
Note: 28.50a Soil pressure at active limit
133.24p Soil pressure at passive limit

Units: kN,m

Stage No.7 Excav. to elev. 43.85 on RIGHT side

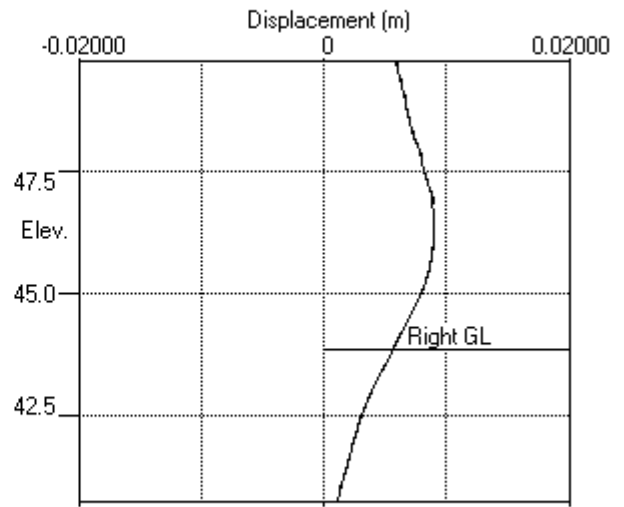
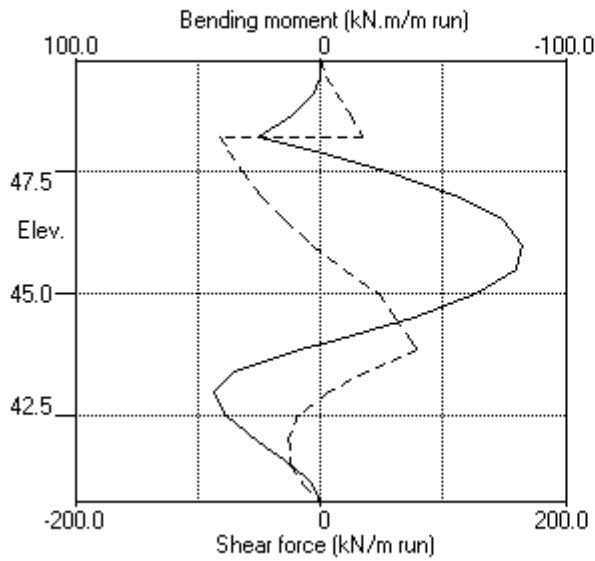

Stage No.7 Excav. to elev. 43.85 on RIGHT side

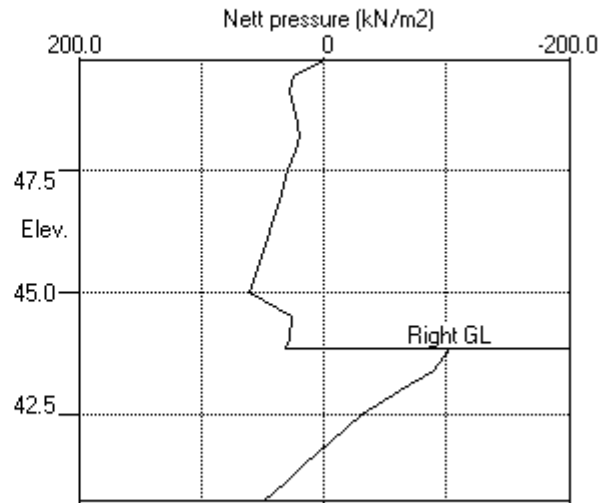
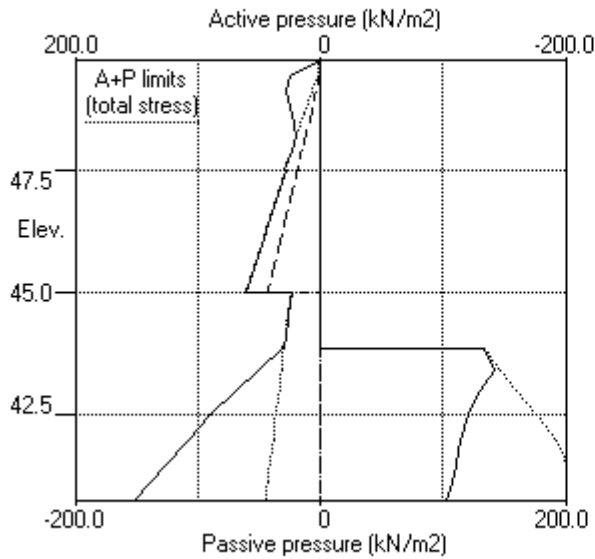

PILEDESIGNS LTD	Sheet No.
Program: WALLAP Version 6.06 Revision A51.B69.R54	Job No. 21495
Licensed from GEOSOLVE	Made by : DBS
Data filename/Run ID: Hampstead_Wall_3_450mm_rev_01_SLS	Date: 1-10-2018
Hampstead - 24-26 Redington Gardens	Checked :
Wall 3, Secant-SLS, 450 dia @ 650 - run 01	

Units: kN,m

Stage No. 9 Change EI of wall to 43355 kN.m²/m run
Yield moment not defined
Allow wall to relax with new modulus value

STABILITY ANALYSIS of Fully Embedded Wall according to Strength Factor method
Factor of safety on soil strength

			FoS for toe elev. = 40.75		Toe elev. for FoS = 1.500		
Stage No.	--- G.L. Act.	--- Pass.	Strut Elev.	Factor of Safety	Moment of equil. at elev.	Toe Wall Penetr-ation	Direction of failure
9	49.75	43.85				No FoS calc.	

BENDING MOMENT and DISPLACEMENT ANALYSIS of Fully Embedded Wall

Analysis options

Length of wall perpendicular to section = 50.00m
Subgrade reaction model - Boussinesq Influence coefficients
Soil deformations are elastic until the active or passive limit is reached
Open Tension Crack analysis - No

Rigid boundaries: Left side 50.00 from wall
Right side 50.00 from wall

Limit State: Serviceability Limit State

Calculated Bending Moments and Strut Forces are to be multiplied by a factor of 1.35 to obtain values for structural design. See summary for factored values.

Node no.	Y coord	Nett pressure kN/m ²	Wall disp. m	Wall rotation rad.	Shear force kN/m	Bending moment kN.m/m	Strut forces kN/m	EI of wall kN.m ² /m
1	49.75	0.00	0.005	-1.24E-03	0.0	0.0		43355
2	49.40	25.67	0.006	-1.24E-03	4.5	0.6		43355
3	49.10	30.24	0.006	-1.25E-03	12.9	2.8		43355
4	48.65	24.91	0.007	-1.33E-03	25.3	11.8		43355
5	48.20	19.81	0.007	-1.52E-03	35.3	25.8	114.3	43355
		19.81	0.007	-1.52E-03	-78.9	25.8		
6	47.90	23.80	0.008	-1.63E-03	-72.4	3.0		43355
7	47.50	29.07	0.008	-1.53E-03	-61.8	-24.2		43355
		28.64	0.008	-1.53E-03	-61.8	-24.2		
8	47.00	35.24	0.009	-1.10E-03	-45.8	-51.6		43355
9	46.50	41.78	0.010	-4.19E-04	-26.6	-70.2		43355
10	46.00	48.23	0.010	4.11E-04	-4.1	-76.6		43355
11	45.50	54.62	0.009	1.25E-03	21.6	-73.3		43355
12	45.00	60.94	0.008	1.98E-03	50.5	-56.1		43355
		23.75	0.008	1.98E-03	50.5	-56.1		
13	44.53	26.12	0.007	2.42E-03	62.4	-30.1		43355
14	44.05	28.50	0.006	2.55E-03	75.3	2.0	16.5	43355
		28.50	0.006	2.55E-03	58.9	2.0		
15	43.85	32.29	0.006	2.50E-03	64.9	15.5		43355
		-99.89	0.006	2.50E-03	64.9	15.5		
16	43.42	-83.21	0.005	2.22E-03	26.0	38.6		43355
17	43.00	-51.59	0.004	1.81E-03	-2.6	43.1		43355
18	42.50	-21.83	0.003	1.36E-03	-21.0	35.9		43355
19	42.00	0.86	0.002	1.03E-03	-26.2	22.8		43355
20	41.50	19.14	0.002	8.61E-04	-21.2	9.5		43355
21	41.13	30.76	0.002	8.12E-04	-11.9	2.6		43355
22	40.75	32.50	0.001	8.03E-04	0.0	-0.0		---
At elev. 48.20		Strut force =		114.3 kN/strut	=	114.3 kN/m run		
At elev. 44.05		Strut force =		16.5 kN/strut	=	16.5 kN/m run		

(continued)

Stage No.9 Change EI of wall to 43355 kN.m2/m run
 Yield moment not defined
 Allow wall to relax with new modulus value

Node no.	Y coord	LEFT side					Total earth pressure	Coeff. of subgrade reaction
		Water press.	Vertic -al	Active limit	Passive limit	Earth pressure		
		kN/m2	kN/m2	kN/m2	kN/m2	kN/m2	kN/m2	kN/m3
1	49.75	0.00	0.00	0.00	0.00	0.00	0.00	6476
2	49.40	0.00	7.46	2.51	25.67	25.67	25.67p	6476
3	49.10	2.94	12.28	4.14	42.28	27.30	30.24	6476
4	48.65	7.36	18.61	6.27	64.07	17.55	24.91	6476
5	48.20	11.77	23.83	8.02	82.01	8.03	19.81	6476
6	47.90	14.71	26.98	9.08	92.89	9.08	23.80a	3050
7	47.50	18.64	30.99	10.43	106.68	10.43	29.07a	3050
		18.64	30.99	10.00	113.02	10.00	28.64a	8791
8	47.00	23.54	36.27	11.70	132.28	11.70	35.24a	8791
9	46.50	28.45	41.32	13.33	150.68	13.33	41.78a	8791
10	46.00	33.35	46.13	14.88	168.21	14.88	48.23a	8791
11	45.50	38.26	50.71	16.36	184.94	16.36	54.62a	8791
12	45.00	43.16	55.11	17.78	200.99	17.78	60.94a	8791
		Total>	98.28	23.75m	217.77	23.75	23.75a	17196
13	44.53	Total>	107.46	26.12m	232.64	26.12	26.12a	18013
14	44.05	Total>	116.56	28.50m	247.41	28.50	28.50a	18830
15	43.85	Total>	120.38	29.50m	253.62	32.29	32.29	23408
16	43.42	Total>	128.46	31.63m	266.78	54.21	54.21	24300
17	43.00	Total>	136.53	33.75m	279.93	74.17	74.17	25192
18	42.50	Total>	146.02	36.25m	295.39	94.53	94.53	26242
19	42.00	Total>	155.52	38.75m	310.86	111.95	111.95	27291
20	41.50	Total>	165.03	41.25m	326.35	127.59	127.59	28341
21	41.13	Total>	172.19	43.13m	337.99	138.35	138.35	129823
22	40.75	Total>	179.36	45.00m	349.64	144.11	144.11	133332

Node no.	Y coord	RIGHT side					Total earth pressure	Coeff. of subgrade reaction
		Water press.	Vertic -al	Active limit	Passive limit	Earth pressure		
		kN/m2	kN/m2	kN/m2	kN/m2	kN/m2	kN/m2	kN/m3
1	49.75	0.00	0.00	0.00	0.00	0.00	0.00	0.0
2	49.40	0.00	0.00	0.00	0.00	0.00	0.00	0.0
3	49.10	0.00	0.00	0.00	0.00	0.00	0.00	0.0
4	48.65	0.00	0.00	0.00	0.00	0.00	0.00	0.0
5	48.20	0.00	0.00	0.00	0.00	0.00	0.00	0.0
6	47.90	0.00	0.00	0.00	0.00	0.00	0.00	0.0
7	47.50	0.00	0.00	0.00	0.00	0.00	0.00	0.0
8	47.00	0.00	0.00	0.00	0.00	0.00	0.00	0.0
9	46.50	0.00	0.00	0.00	0.00	0.00	0.00	0.0
10	46.00	0.00	0.00	0.00	0.00	0.00	0.00	0.0
11	45.50	0.00	0.00	0.00	0.00	0.00	0.00	0.0
12	45.00	0.00	0.00	0.00	0.00	0.00	0.00	0.0
13	44.53	0.00	0.00	0.00	0.00	0.00	0.00	0.0
14	44.05	0.00	0.00	0.00	0.00	0.00	0.00	0.0
15	43.85	0.00	0.00	0.00	0.00	0.00	0.00	0.0
		Total>	0.00	0.00	133.24	132.19	132.19	23408
16	43.42	Total>	8.50	2.12m	146.82	137.42	137.42	24300
17	43.00	Total>	17.00	4.25m	160.40	125.76	125.76	25192
18	42.50	Total>	27.00	6.75m	176.37	116.36	116.36	26242
19	42.00	Total>	37.00	9.25m	192.35	111.10	111.10	27291
20	41.50	Total>	47.00	11.75m	208.33	108.44	108.44	28341
21	41.13	Total>	54.51	13.62m	220.31	107.59	107.59	129823

Run ID. Hampstead_Wall_3_450mm_rev_01_SLS
 Hampstead - 24-26 Redington Gardens
 Wall 3, Secant-SLS, 450 dia @ 650 - run 01

| Sheet No.
 | Date: 1-10-2018
 | Checked :

(continued)

Stage No.9 Change EI of wall to 43355 kN.m2/m run
 Yield moment not defined
 Allow wall to relax with new modulus value

Node no.	Y coord	----- RIGHT side -----					Total earth pressure	Coeff. of subgrade reaction
		Water press.	Vertic -al	Effective Active limit	Effective Passive limit	Earth pressure		
		kN/m2	kN/m2	kN/m2	kN/m2	kN/m2	kN/m2	kN/m3
22	40.75	Total>	62.01	15.50m	232.29	111.60	111.60	133332

Note: 28.50a Soil pressure at active limit
 25.67p Soil pressure at passive limit

Units: kN,m

Stage No.9 Change EI of wall to 43355kN.m2/m run

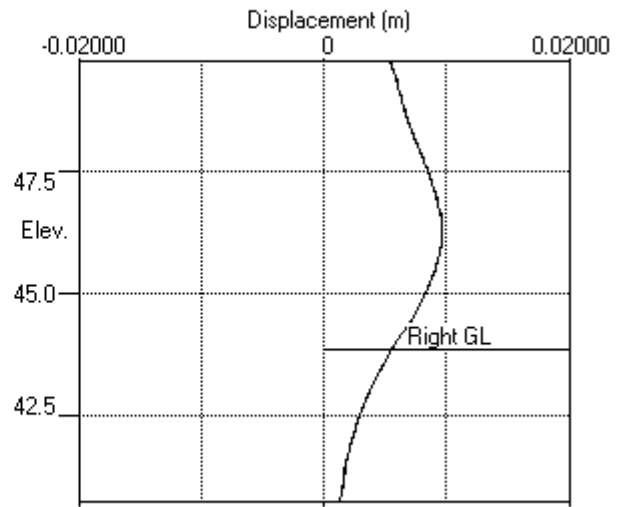
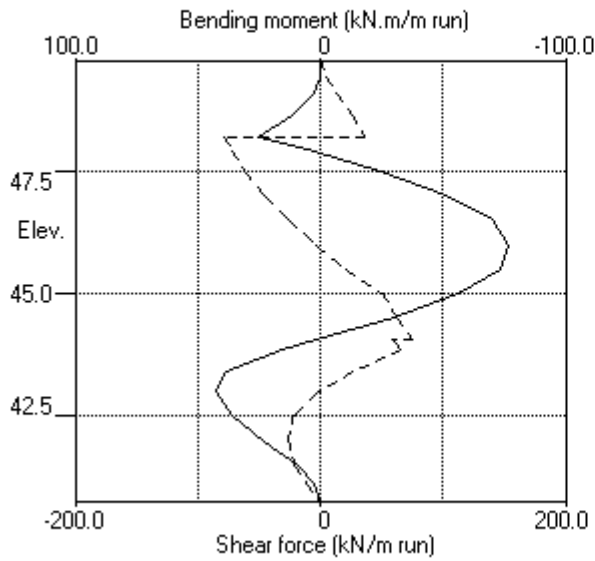

Stage No.9 Change EI of wall to 43355kN.m2/m run

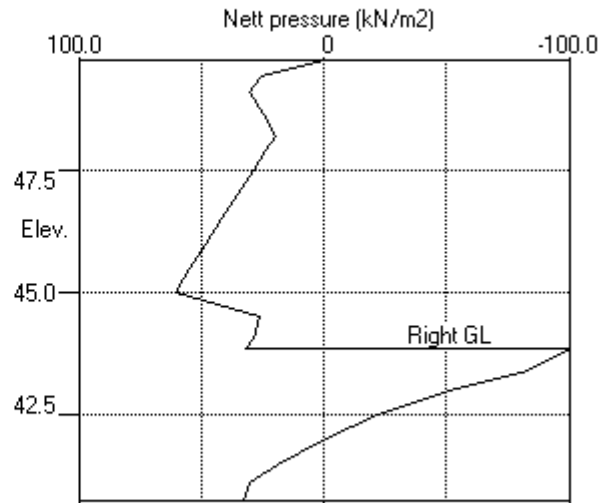
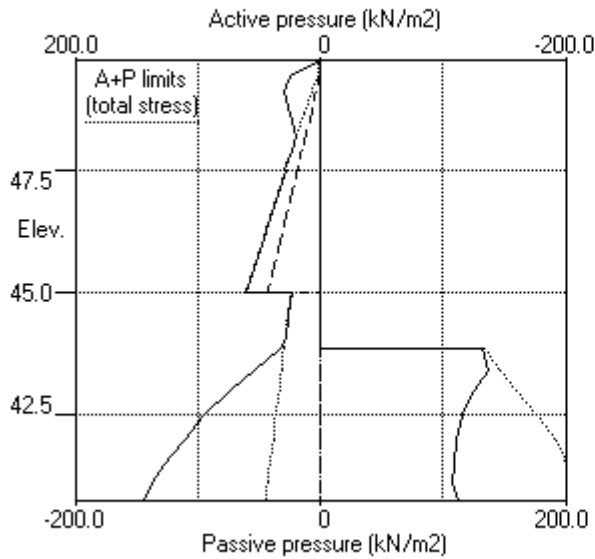

PILEDESIGNS LTD
 Program: WALLAP Version 6.06 Revision A51.B69.R54
 Licensed from GEOSOLVE
 Data filename/Run ID: Hampstead_Wall_3_450mm_rev_01_SLS
 Hampstead - 24-26 Redington Gardens
 Wall 3, Secant-SLS, 450 dia @ 650 - run 01

Sheet No.
 Job No. 21495
 Made by : DBS
 Date: 1-10-2018
 Checked :

Units: kN,m

Stage No. 10 Change properties of soil type 3 to soil type 4
 Ko pressures will not be reset

STABILITY ANALYSIS of Fully Embedded Wall according to Strength Factor method
 Factor of safety on soil strength

Stage No.	--- G.L. --- Act. Pass.	Strut Elev.	FoS for toe elev. = 40.75	Moment of equil. at elev.	Toe elev. for FoS = 1.500	Wall Penetr -ation	Direction of failure
10	49.75 43.85			More than one strut.	No FoS calc.		

BENDING MOMENT and DISPLACEMENT ANALYSIS of Fully Embedded Wall

Analysis options

Length of wall perpendicular to section = 50.00m
 Subgrade reaction model - Boussinesq Influence coefficients
 Soil deformations are elastic until the active or passive limit is reached
 Open Tension Crack analysis - No

Rigid boundaries: Left side 50.00 from wall
 Right side 50.00 from wall

Limit State: Serviceability Limit State

Calculated Bending Moments and Strut Forces are to be multiplied by a factor of 1.35 to obtain values for structural design. See summary for factored values.

Node no.	Y coord	Nett pressure kN/m2	Wall disp. m	Wall rotation rad.	Shear force kN/m	Bending moment kN.m/m	Strut forces kN/m	EI of wall kN.m2/m
1	49.75	0.00	0.006	-1.06E-03	0.0	0.0		43355
2	49.40	24.26	0.006	-1.06E-03	4.2	0.6		43355
3	49.10	29.18	0.006	-1.08E-03	12.3	2.7		43355
4	48.65	24.39	0.007	-1.15E-03	24.3	11.3		43355
5	48.20	19.82	0.007	-1.34E-03	34.3	24.8	110.1	43355
		19.82	0.007	-1.34E-03	-75.8	24.8		
6	47.90	23.99	0.008	-1.44E-03	-69.3	2.9		43355
7	47.50	29.50	0.008	-1.35E-03	-58.6	-23.0		43355
		29.87	0.008	-1.35E-03	-58.6	-23.0		
8	47.00	37.27	0.009	-9.47E-04	-41.8	-48.6		43355
9	46.50	44.44	0.009	-3.04E-04	-21.3	-64.9		43355
10	46.00	51.25	0.009	4.48E-04	2.6	-68.4		43355
11	45.50	57.55	0.009	1.17E-03	29.8	-61.4		43355
12	45.00	63.17	0.008	1.73E-03	60.0	-39.8		43355
		62.52	0.008	1.73E-03	60.0	-39.8		
13	44.53	68.77	0.007	1.95E-03	91.1	-4.7		43355
14	44.05	74.99	0.006	1.70E-03	125.3	46.0	203.8	43355
		74.99	0.006	1.70E-03	-78.5	46.0		
15	43.85	77.61	0.006	1.51E-03	-63.2	32.9		43355
16	43.42	55.50	0.005	1.25E-03	-34.9	16.4		43355
17	43.00	33.39	0.005	1.14E-03	-16.1	5.9		43355
18	42.50	18.43	0.004	1.10E-03	-3.1	0.8		43355
19	42.00	3.46	0.004	1.11E-03	2.4	0.0		43355
20	41.50	-8.56	0.003	1.11E-03	1.1	0.8		43355
21	41.13	-0.36	0.003	1.11E-03	-0.6	0.5		43355
22	40.75	3.45	0.002	1.11E-03	0.0	0.0		---
At elev. 48.20		Strut force =	110.1 kN/strut =		110.1 kN/m run			
At elev. 44.05		Strut force =	203.8 kN/strut =		203.8 kN/m run			

(continued)

Stage No.10 Change properties of soil type 3 to soil type 4
Ko pressures will not be reset

Node no.	Y coord	LEFT side					Total earth pressure kN/m2	Coeff. of subgrade reaction kN/m3
		Water press. kN/m2	Vertical kN/m2	Effective Active limit kN/m2	Effective Passive limit kN/m2	Earth pressure kN/m2		
1	49.75	0.00	0.00	0.00	0.00	0.00	0.00	6769
2	49.40	0.00	7.46	2.51	25.67	24.26	24.26	6769
3	49.10	2.94	12.28	4.14	42.28	26.24	29.18	6769
4	48.65	7.36	18.61	6.27	64.07	17.03	24.39	6769
5	48.20	11.77	23.83	8.02	82.01	8.05	19.82	3124
6	47.90	14.71	26.98	9.08	92.89	9.28	23.99	3124
7	47.50	18.64	30.99	10.43	106.68	10.86	29.50	3124
		18.64	30.99	10.00	113.02	11.23	29.87	9004
8	47.00	23.54	36.27	11.70	132.28	13.73	37.27	9004
9	46.50	28.45	41.32	13.33	150.68	15.99	44.44	9004
10	46.00	33.35	46.13	14.88	168.21	17.89	51.25	9004
11	45.50	38.26	50.71	16.36	184.94	19.29	57.55	9004
12	45.00	43.16	55.11	17.78	200.99	20.01	63.17	9004
		43.16	55.11	19.36	179.27	19.36	62.52a	9244
13	44.53	47.82	59.64	20.95	193.99	20.95	68.77a	9683
14	44.05	52.48	64.08	22.51	208.44	22.51	74.99a	9655
15	43.85	54.45	65.93	23.16	214.46	23.16	77.61a	9831
16	43.42	58.61	69.85	24.54	227.20	24.54	83.15a	10206
17	43.00	62.78	73.75	25.91	239.88	25.91	88.69a	10581
18	42.50	67.69	78.33	27.52	254.79	27.52	95.20a	11022
19	42.00	72.59	82.92	29.13	269.73	29.13	101.72a	11463
20	41.50	77.50	87.53	30.75	284.73	33.68	111.18	11904
21	41.13	81.18	91.01	31.97	296.03	41.61	122.79	12234
22	40.75	84.86	94.50	33.20	307.39	44.72	129.58	12565

Node no.	Y coord	RIGHT side					Total earth pressure kN/m2	Coeff. of subgrade reaction kN/m3
		Water press. kN/m2	Vertical kN/m2	Effective Active limit kN/m2	Effective Passive limit kN/m2	Earth pressure kN/m2		
1	49.75	0.00	0.00	0.00	0.00	0.00	0.00	0.0
2	49.40	0.00	0.00	0.00	0.00	0.00	0.00	0.0
3	49.10	0.00	0.00	0.00	0.00	0.00	0.00	0.0
4	48.65	0.00	0.00	0.00	0.00	0.00	0.00	0.0
5	48.20	0.00	0.00	0.00	0.00	0.00	0.00	0.0
6	47.90	0.00	0.00	0.00	0.00	0.00	0.00	0.0
7	47.50	0.00	0.00	0.00	0.00	0.00	0.00	0.0
8	47.00	0.00	0.00	0.00	0.00	0.00	0.00	0.0
9	46.50	0.00	0.00	0.00	0.00	0.00	0.00	0.0
10	46.00	0.00	0.00	0.00	0.00	0.00	0.00	0.0
11	45.50	0.00	0.00	0.00	0.00	0.00	0.00	0.0
12	45.00	0.00	0.00	0.00	0.00	0.00	0.00	0.0
13	44.53	0.00	0.00	0.00	0.00	0.00	0.00	0.0
14	44.05	0.00	0.00	0.00	0.00	0.00	0.00	0.0
15	43.85	0.00	0.00	0.00	0.00	0.00	0.00	0.0
		0.00	0.00	0.00	0.00	0.00	0.00	9831
16	43.42	0.00	8.50	2.99	27.65	27.65	27.65p	10206
17	43.00	0.00	17.00	5.97	55.30	55.30	55.30p	10581
18	42.50	4.90	22.10	7.76	71.87	71.87	76.78p	11022
19	42.00	9.81	27.19	9.55	88.45	88.45	98.26p	11463
20	41.50	14.71	32.29	11.34	105.03	105.03	119.75p	11904
21	41.13	18.39	36.11	12.69	117.47	104.75	123.14	12234
22	40.75	22.07	39.94	14.03	129.91	104.06	126.13	12565

Run ID. Hampstead_Wall_3_450mm_rev_01_SLS
Hampstead - 24-26 Redington Gardens
Wall 3, Secant-SLS, 450 dia @ 650 - run 01

| Sheet No.
| Date: 1-10-2018
| Checked :

(continued)

Stage No.10 Change properties of soil type 3 to soil type 4
Ko pressures will not be reset
Note: 101.72a Soil pressure at active limit
119.75p Soil pressure at passive limit

Units: kN,m

Stage No.10 Change soil type 3 to soil type 4

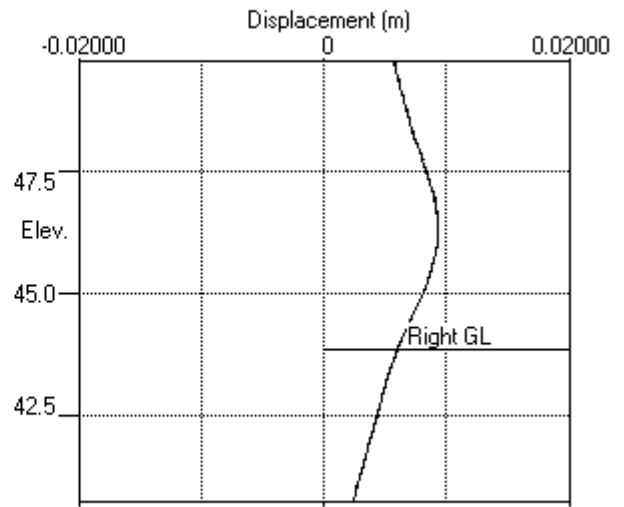
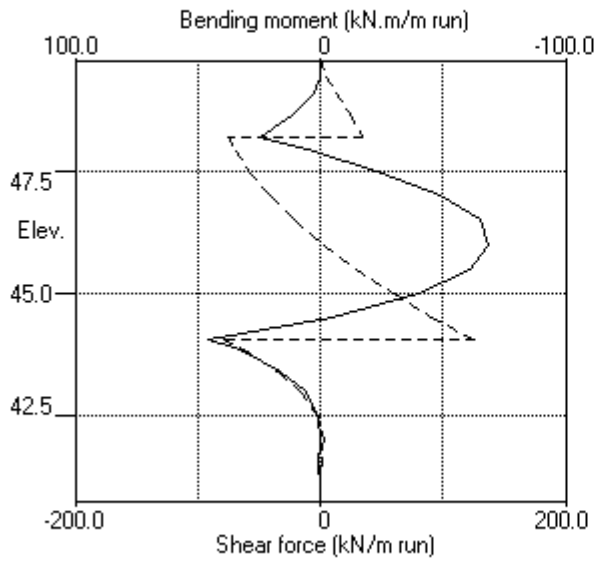

Stage No.10 Change soil type 3 to soil type 4

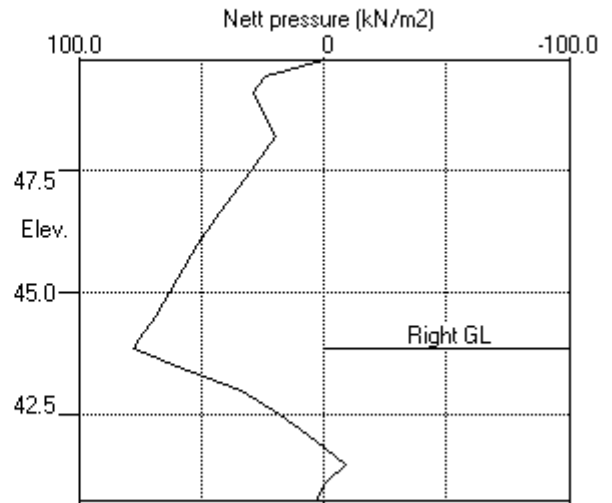
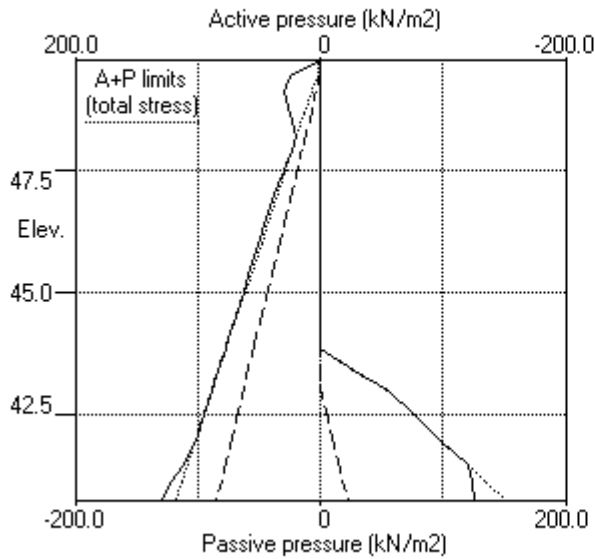

PILEDESIGNS LTD
 Program: WALLAP Version 6.06 Revision A51.B69.R54
 Licensed from GEOSOLVE
 Data filename/Run ID: Hampstead_Wall_3_450mm_rev_01_SLS
 Hampstead - 24-26 Redington Gardens
 Wall 3, Secant-SLS, 450 dia @ 650 - run 01

Sheet No.
 Job No. 21495
 Made by : DBS
 Date: 1-10-2018
 Checked :

 Units: kN,m

Summary of results

LIMIT STATE PARAMETERS

Limit State: Serviceability Limit State
 All loads and soil strengths are unfactored

STABILITY ANALYSIS of Fully Embedded Wall according to Strength Factor method
 Factor of safety on soil strength

Stage No.	G.L.		Strut Elev.	FoS for toe elev. = 40.75		Toe elev. for FoS = 1.500		Direction of failure
	Act.	Pass.		Factor of Safety	Moment at elev.	Toe elev.	Wall Penetration	
1	49.75	49.75	Cant.	Conditions not suitable for FoS calc.				
2	49.75	49.75	Cant.	Conditions not suitable for FoS calc.				
3	49.75	49.75	Cant.	Conditions not suitable for FoS calc.				
4	49.75	47.90	Cant.	2.256	41.80	42.60	5.30	L to R
5	49.75	47.90	No analysis at this stage					
6	49.75	47.90	48.20	6.398	n/a	46.90	1.00	L to R
7	49.75	43.85	48.20	2.138	n/a	42.75	1.10	L to R
8	49.75	43.85	No analysis at this stage					

All remaining stages have more than one strut - FoS calculation n/a

PILEDESIGNS LTD
 Program: WALLAP Version 6.06 Revision A51.B69.R54
 Licensed from GEOSOLVE
 Data filename/Run ID: Hampstead_Wall_3_450mm_rev_01_SLS
 Hampstead - 24-26 Redington Gardens
 Wall 3, Secant-SLS, 450 dia @ 650 - run 01

Sheet No.
 Job No. 21495
 Made by : DBS
 Date: 1-10-2018
 Checked :

Units: kN,m

Summary of results

BENDING MOMENT and DISPLACEMENT ANALYSIS of Fully Embedded Wall

Analysis options

Length of wall perpendicular to section = 50.00m
 Subgrade reaction model - Boussinesq Influence coefficients
 Soil deformations are elastic until the active or passive limit is reached
 Open Tension Crack analysis - No

Rigid boundaries: Left side 50.00 from wall
 Right side 50.00 from wall

Limit State: Serviceability Limit State

Calculated Bending Moments and Strut Forces have been multiplied by a factor of 1.35 to obtain values for structural design.

Bending moment, shear force and displacement envelopes

Node no.	Y coord	Displacement		Bending moment				Shear force			
		max. m	min. m	Calculated kN.m/m		Factored kN.m/m		Calculated kN/m		Factored kN/m	
1	49.75	0.011	0.000	0	0	0	0	0	0	0	0
2	49.40	0.010	0.000	1	-0	1	-0	4	-1	6	-1
3	49.10	0.010	0.000	3	-0	4	-1	13	-2	17	-3
4	48.65	0.008	0.000	12	-2	16	-2	25	-2	34	-3
5	48.20	0.007	0.000	26	-3	35	-3	35	-82	48	-110
6	47.90	0.008	0.000	12	-3	16	-4	21	-75	28	-101
7	47.50	0.008	0.000	22	-26	29	-36	26	-65	35	-87
8	47.00	0.009	0.000	34	-55	46	-74	24	-49	32	-66
9	46.50	0.010	0.000	44	-74	59	-101	14	-29	18	-40
10	46.00	0.010	0.000	49	-82	66	-111	3	-7	3	-9
11	45.50	0.009	0.000	45	-80	60	-108	30	-11	40	-15
12	45.00	0.008	0.000	37	-64	50	-86	60	-16	81	-22
13	44.53	0.007	0.000	29	-39	38	-52	91	-18	123	-25
14	44.05	0.006	0.000	46	-7	62	-10	125	-78	169	-106
15	43.85	0.006	0.000	33	0	44	0	79	-63	106	-85
16	43.42	0.005	0.000	39	0	52	0	38	-35	51	-47
17	43.00	0.005	0.000	43	0	59	0	6	-16	7	-22
18	42.50	0.004	0.000	39	0	52	0	0	-21	0	-28
19	42.00	0.004	0.000	26	0	35	0	2	-27	3	-36
20	41.50	0.003	0.000	12	0	16	0	1	-24	1	-33
21	41.13	0.003	0.000	4	-0	5	-0	0	-15	0	-21
22	40.75	0.002	0.000	0	-0	0	-0	0	0	0	0

Summary of results (continued)

Calculated Bending Moments and Strut Forces have been multiplied by a factor of 1.35 to obtain values for structural design.

Maximum and minimum bending moment and shear force at each stage

Stage no.	Bending moment						Shear force					
	Calculated		Factored		Calculated		Factored					
min.	max. elev.	min. elev.	max. elev.	max. elev.	min. elev.	max. elev.	min. elev.	max. elev.	min. elev.	max. elev.	min. elev.	max. elev.
	kN.m/m		kN.m/m		kN.m/m		kN/m		kN/m		kN/m	
1	2	43.42	-3	46.50	2	-3	3	45.00	-1	48.20	4	
-2	2	43.42	-4	46.50	2	-5	4	45.00	-2	47.90	6	
-2	3	44.05	-3	47.90	5	-4	5	45.00	-2	48.65	7	
-3	4	46.00	-0	41.13	66	-0	26	47.50	-18	44.53	35	
-25	No calculation at this stage											
5	40	46.00	-0	40.75	54	-0	21	47.50	-13	44.05	28	
-18	43	43.00	-82	46.00	59	-111	79	43.85	-82	48.20	106	
-110	No calculation at this stage											
8	43	43.00	-77	46.00	58	-103	75	44.05	-79	48.20	102	
-107	46	44.05	-68	46.00	62	-92	125	44.05	-78	44.05	169	
-106	No calculation at this stage											
11	28	44.05	-74	46.00	38	-100	118	44.05	-78	48.20	160	
-105												

Maximum and minimum displacement at each stage

Stage no.	Displacement				Stage description
	maximum	elev.	minimum	elev.	
	m		m		
1	0.001	49.75	0.000	49.75	Apply surcharge no.1 at elev. 49.75
2	0.001	47.50	0.000	49.75	Apply surcharge no.2 at elev. 49.10
3	0.002	49.75	0.000	49.75	Apply water pressure profile no.1
4	0.011	49.75	0.000	49.75	Excav. to elev. 47.90 on RIGHT side
5	No calculation at this stage				Install strut no.1 at elev. 48.20
6	0.011	49.75	0.000	49.75	Apply water pressure profile no.2
7	0.009	46.50	0.000	49.75	Excav. to elev. 43.85 on RIGHT side
8	No calculation at this stage				Install strut no.2 at elev. 44.05
9	0.010	46.00	0.000	49.75	Change EI of wall to 43355kN.m ² /m run
10	0.009	46.50	0.000	49.75	Change soil type 3 to soil type 4
11	No calculation at this stage				Apply surcharge no.3 at elev. 43.85
12	0.009	46.00	0.000	49.75	Apply water pressure profile no.3

Strut forces at each stage (horizontal components)

Stage no.	Strut no. 1			Strut no. 2		
	at elev. 48.20			at elev. 44.05		
	Calculated	Factored	Calculated	Factored	Calculated	Factored
	kN per m run	kN per strut	kN per m run	kN per strut	kN per m run	kN per strut
6	7	7	9	---	---	---
7	116	116	156	---	---	---
9	114	114	154	16	16	22
10	110	110	149	204	204	275
12	113	113	152	160	160	216

Units: kN,m

Bending moment, shear force, displacement envelopes

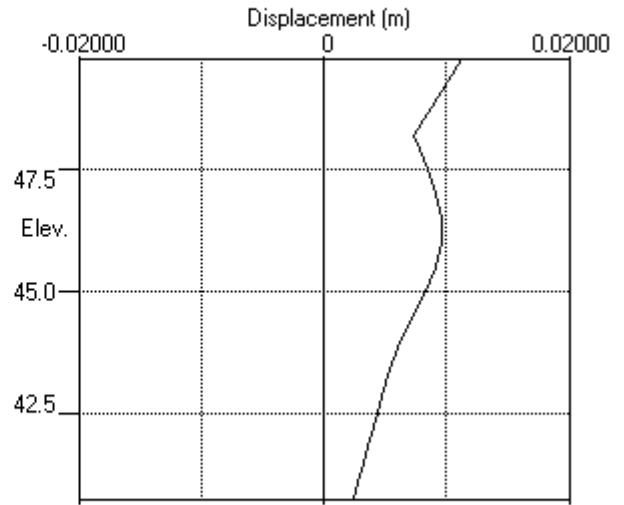
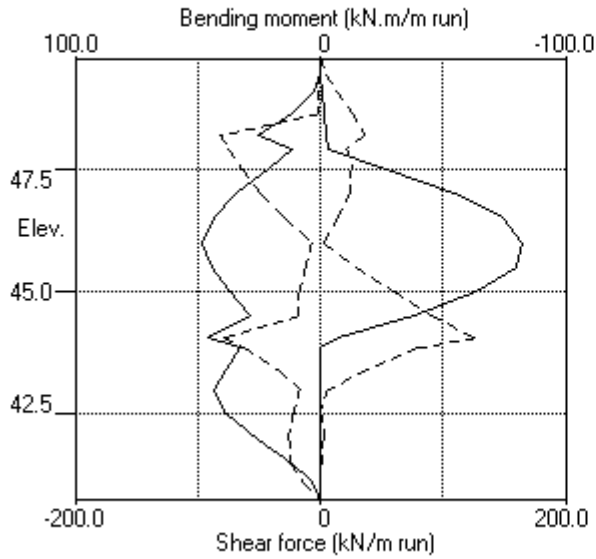



WALLAP

4-ULS1

PILEDESIGNS LTD
 Program: WALLAP Version 6.06 Revision A51.B69.R54
 Licensed from GEOSOLVE
 Data filename/Run ID: Hampstead_Wall_4_450mm_rev_01_ULS1
 Hampstead - 24-26 Redington Gardens
 Wall 4, Secant-ULS1, 450 dia @ 650 - run 01

Sheet No.
 Job No. 21495
 Made by : DBS
 Date: 1-10-2018
 Checked :

Units: kN,m

INPUT DATA

SOIL PROFILE

Stratum no.	Elevation of top of stratum	Soil types	
		Left side	Right side
1	49.75	1 Made Ground dr	1 Made Ground dr
2	47.50	2 Claygate Clay dr	2 Claygate Clay dr
3	45.00	3 London Clay und	3 London Clay und

SOIL PROPERTIES (Unfactored SLS soil strengths)

No. Description (Datum elev.)	Bulk density kN/m3	Young's Modulus Eh, kN/m2 (dEh/dy)	At rest coeff. Ko (dKo/dy)	Consol state. NC/OC (Nu)	Active limit Ka (Kac)	Passive limit Kp (Kpc)	Cohesion kN/m2 (dc/dy)
1 Made Ground dr	18.00	10000	0.530	OC (0.250)	0.337 (0.000)	3.442 (0.000)	
2 Claygate Clay dr	19.00	30000	1.000	NC (0.200)	0.323 (1.330)	3.647 (5.195)	0.0d
3 London Cl.. (45.00)	20.00	40000 (4000)	1.000	OC (0.490)	1.000 (2.476)	1.000 (2.390)	50.00u (5.000)
4 London Cl.. (45.00)	20.00	30800 (3080)	1.000	OC (0.200)	0.351 (1.391)	3.253 (4.831)	0.0d

Additional soil parameters associated with Ka and Kp

No. Description	--- parameters for Ka ---			--- parameters for Kp ---		
	Soil friction angle	Wall adhesion coeff.	Back-fill angle	Soil friction angle	Wall adhesion coeff.	Back-fill angle
1 Made Ground dr	26.00	0.670	0.00	26.00	0.500	0.00
2 Claygate Clay dr	27.00	0.670	0.00	27.00	0.500	0.00
3 London Clay und	0.00	0.670	0.00	0.00	0.500	0.00
4 London Clay dr	25.00	0.670	0.00	25.00	0.500	0.00

GROUND WATER CONDITIONS

Density of water = 9.810 kN/m3

	Left side	Right side
Initial water table elevation	48.30	48.30

Automatic water pressure balancing at toe of wall : No

Water profile no.	Left side				Right side			
	Point no.	Elev. m	Piezo elev. m	Water press. kN/m2	Point no.	Elev. m	Piezo elev. m	Water press. kN/m2
1	1	48.30	48.30	0.0	1	47.50	47.50	0.0 MC+WC
2	1	48.30	48.30	0.0	1	43.00	43.00	0.0 MC+WC
3	1	48.30	48.30	0.0	1	43.65	43.65	0.0 MC+WC
					2	43.65	48.30	45.6

WALL PROPERTIES

Type of structure = Fully Embedded Wall
 Elevation of toe of wall = 40.75
 Maximum finite element length = 0.50 m
 Youngs modulus of wall E = 1.9600E+07 kN/m2
 Moment of inertia of wall I = 3.0968E-03 m4/m run
 E.I = 60696 kN.m2/m run
 Yield Moment of wall = Not defined

STRUTS and ANCHORS

Strut/ anchor no.	Elev.	Strut spacing m	X-section area of strut sq.m	Youngs modulus kN/m2	Free length m	Inclin -ation (degs)	Pre- stress /strut kN	Tension allowed
1	48.21	1.00	0.400000	1.400E+07	5.00	0.00	0	No
2	43.85	1.00	0.300000	1.400E+07	5.00	0.00	0	No

SURCHARGE LOADS

Surch -arge no.	Elev.	Distance from wall	Length parallel to wall	Width perpend. to wall	Surcharge ----- kN/m2 ----- Near edge Far edge		Equiv. soil type	Partial factor/ Category
1	48.30	0.50(L)	10.00	10.00	10.00	=	N/A	1.10 Var
2	43.65	-0.00(R)	10.00	10.00	46.00	=	N/A	1.00 P/F

Note: L = Left side, R = Right side

Limit State Categories P/U = Permanent Unfavourable
P/F = Permanent Favourable
Var = Variable (unfavourable)

CONSTRUCTION STAGES

Construction stage no.	Stage description
1	Excavate to elevation 48.30 on LEFT side
2	Apply surcharge no.1 at elevation 48.30
3	Apply water pressure profile no.1 (Mod. Conserv.)
4	Excavate to elevation 47.70 on RIGHT side
5	Install strut or anchor no.1 at elevation 48.21
6	Apply water pressure profile no.2 (Mod. Conserv.)
7	Excavate to elevation 43.19 on RIGHT side
8	Fill to elevation 43.65 on RIGHT side with soil type 1
9	Install strut or anchor no.2 at elevation 43.85
10	Change EI of wall to 43355 kN.m2/m run Yield moment not defined Allow wall to relax with new modulus value
11	Change properties of soil type 3 to soil type 4 Ko pressures will not be reset
12	Apply surcharge no.2 at elevation 43.65 No analysis at this stage
13	Apply water pressure profile no.3 (Mod. Conserv.)

FACTORS OF SAFETY and ANALYSIS OPTIONS

Limit State options: ULS DA1 Combination 1
Water pressures : Moderately Conservative
Partial factor on C' = 1.000
Partial factor on Phi' = 1.000
Partial factor on Cu = 1.000
Partial factor on Soil Modulus = 1.000
Partial factor on Permanent Unfavourable loads = 1.000
Partial factor on Permanent Favourable loads = 1.000
Partial factor on Variable Unfavourable loads = 1.100
Design factor on calculated Bending Moments = 1.350

Parameters for undrained strata:

Minimum equivalent fluid density = 5.00 kN/m3
Maximum depth of water filled tension crack = 0.00 m

Bending moment and displacement calculation:

Method - Subgrade reaction model using Influence Coefficients
Open Tension Crack analysis? - No
Non-linear Modulus Parameter (L) = 9.000 m

Boundary conditions:

Length of wall (normal to plane of analysis) = 50.00 m

Width of excavation on Left side of wall = 50.00 m
Width of excavation on Right side of wall = 50.00 m

Distance to rigid boundary on Left side = 50.00 m
Distance to rigid boundary on Right side = 50.00 m

OUTPUT OPTIONS

Stage no.	Stage description	Output options		
		Displacement	Active, Graph.	Passive output
		Bending mom.	pressures	
		Shear force		
1	Excav. to elev. 48.30 on LEFT side	Yes	Yes	Yes
2	Apply surcharge no.1 at elev. 48.30	No	No	No
3	Apply water pressure profile no.1	Yes	Yes	Yes
4	Excav. to elev. 47.70 on RIGHT side	Yes	Yes	Yes
5	Install strut no.1 at elev. 48.21	Yes	Yes	Yes
6	Apply water pressure profile no.2	Yes	Yes	Yes
7	Excav. to elev. 43.19 on RIGHT side	Yes	Yes	Yes
8	Fill to elev. 43.65 on RIGHT side	Yes	Yes	Yes
9	Install strut no.2 at elev. 43.85	Yes	Yes	Yes
10	Change EI of wall to 43355kN.m2/m run	No	No	No
11	Change soil type 3 to soil type 4	No	No	No
12	Apply surcharge no.2 at elev. 43.65	No	No	No
13	Apply water pressure profile no.3	No	No	No
*	Summary output	Yes	-	Yes

Program WALLAP - Copyright (C) 2017 by DL Borin, distributed by GEOSOLVE
 150 St. Alphonsus Road, London SW4 7BW, UK www.geosolve.co.uk

Units: kN,m
 Stage No.13 Apply water pressure profile no.3 (Mod. Conserv.)

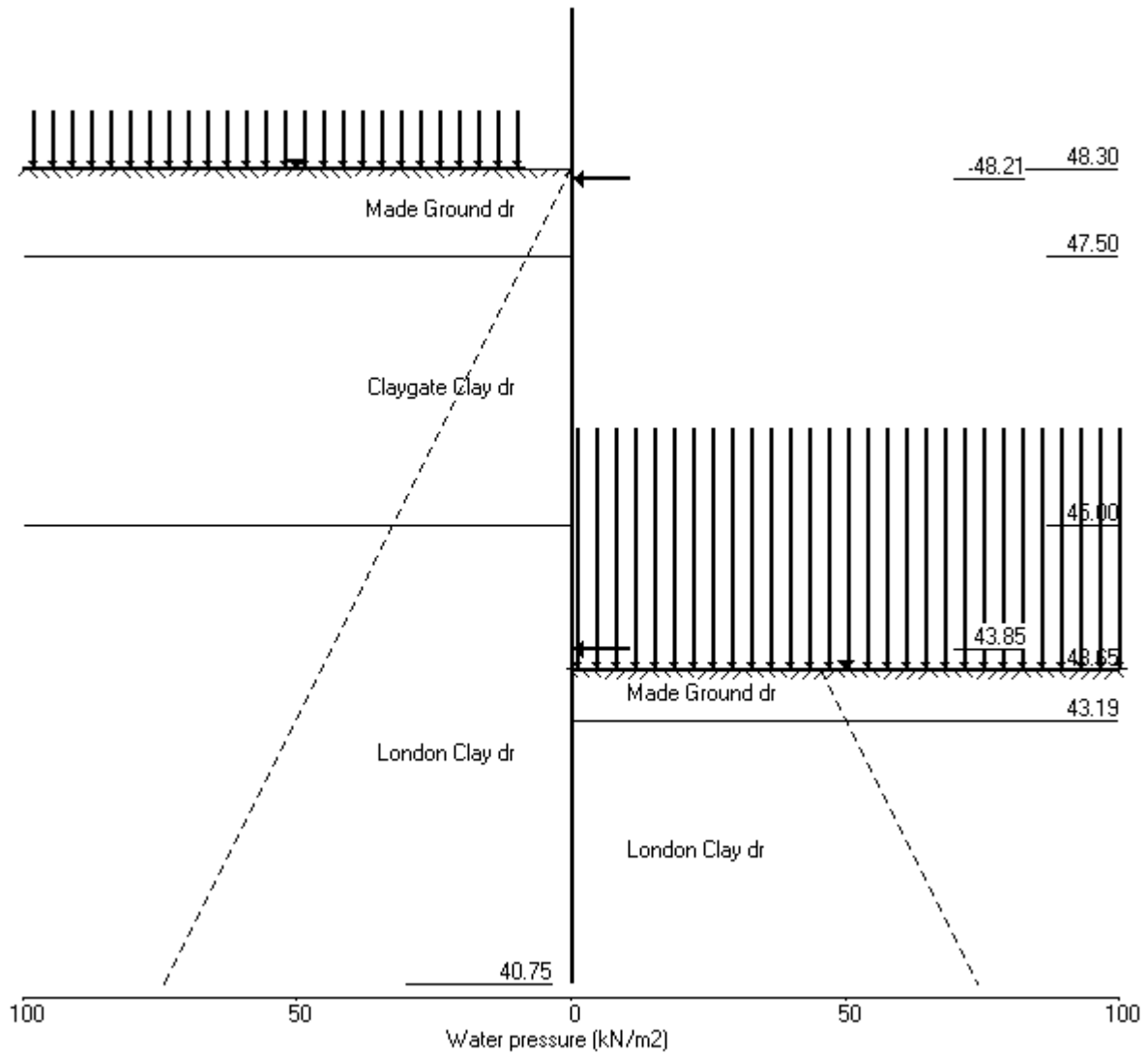

PILEDESIGNS LTD
 Program: WALLAP Version 6.06 Revision A51.B69.R54
 Licensed from GEOSOLVE
 Data filename/Run ID: Hampstead_Wall_4_450mm_rev_01_ULS1
 Hampstead - 24-26 Redington Gardens
 Wall 4, Secant-ULS1, 450 dia @ 650 - run 01

Sheet No.
 Job No. 21495
 Made by : DBS
 Date: 1-10-2018
 Checked :

Units: kN,m

Stage No. 1 Excavate to elevation 48.30 on LEFT side

BENDING MOMENT and DISPLACEMENT ANALYSIS of Fully Embedded Wall

Analysis options

Length of wall perpendicular to section = 50.00m
 Subgrade reaction model - Boussinesq Influence coefficients
 Soil deformations are elastic until the active or passive limit is reached
 Open Tension Crack analysis - No

Rigid boundaries: Left side 50.00 from wall
 Right side 50.00 from wall

Limit State: ULS DA1 Combination 1

Calculated Bending Moments and Strut Forces are to be multiplied by a factor of 1.35 to obtain values for structural design. See summary for factored values.

Node no.	Y coord	Nett pressure kN/m2	Wall disp. m	Wall rotation rad.	Shear force kN/m	Bending moment kN.m/m	Strut forces kN/m	EI of wall kN.m2/m
1	49.75	0.00	-0.002	-5.94E-04	0.0	0.0		60696
2	49.38	-2.27	-0.002	-5.94E-04	-0.4	-0.1		60696
3	49.00	-4.54	-0.002	-5.92E-04	-1.7	-0.4		60696
4	48.65	-6.67	-0.002	-5.87E-04	-3.7	-1.3		60696
5	48.30	-8.79	-0.001	-5.74E-04	-6.4	-3.1		60696
6	48.21	-6.51	-0.001	-5.69E-04	-7.1	-3.7		60696
7	47.96	-0.94	-0.001	-5.50E-04	-8.0	-5.6		60696
8	47.70	0.39	-0.001	-5.22E-04	-8.1	-7.7		60696
9	47.50	-0.41	-0.001	-4.93E-04	-8.1	-9.4		60696
		2.22	-0.001	-4.93E-04	-8.1	-9.4		
10	47.00	12.05	-0.001	-4.03E-04	-4.5	-12.6		60696
11	46.50	8.38	-0.001	-2.94E-04	0.6	-13.8		60696
12	46.00	5.67	-0.001	-1.86E-04	4.1	-12.4		60696
13	45.50	4.09	-0.000	-9.58E-05	6.5	-9.7		60696
14	45.00	3.40	-0.000	-3.17E-05	8.4	-5.9		60696
		-6.06	-0.000	-3.17E-05	8.4	-5.9		
15	44.50	-5.38	-0.000	2.60E-06	5.6	-2.4		60696
16	44.17	-4.65	-0.000	1.16E-05	3.9	-0.9		60696
17	43.85	-3.83	-0.000	1.37E-05	2.5	0.1		60696
18	43.65	-3.32	-0.000	1.27E-05	1.8	0.5		60696
19	43.19	-2.20	-0.000	6.75E-06	0.6	1.0		60696
20	43.00	-1.78	-0.000	3.42E-06	0.2	1.1		60696
21	42.50	-0.83	-0.000	-5.10E-06	-0.5	1.0		60696
22	42.00	-0.10	-0.000	-1.17E-05	-0.7	0.6		60696
23	41.50	0.46	-0.000	-1.54E-05	-0.6	0.3		60696
24	41.13	0.81	-0.000	-1.65E-05	-0.4	0.1		60696
25	40.75	1.13	-0.000	-1.67E-05	-0.0	-0.0		---

Node no.	Y coord	----- LEFT side -----						Total earth pressure kN/m2	Coeff. of subgrade reaction kN/m3
		----- Effective stresses -----							
		Water press. kN/m2	Vertic-al kN/m2	Active limit kN/m2	Passive limit kN/m2	Earth pressure kN/m2			
1	49.75	0.00	0.00	0.00	0.00	0.00	0.00	0.0	
2	49.38	0.00	0.00	0.00	0.00	0.00	0.00	0.0	
3	49.00	0.00	0.00	0.00	0.00	0.00	0.00	0.0	
4	48.65	0.00	0.00	0.00	0.00	0.00	0.00	0.0	
5	48.30	0.00	0.00	0.00	0.00	0.00	0.00	0.0	
		0.00	0.00	0.00	0.00	0.00	0.00	4238	
6	48.21	0.88	0.74	0.25	2.54	2.54	3.42p	4238	
7	47.96	3.38	2.83	0.95	9.73	9.73	13.11p	4238	

(continued)

Stage No.1 Excavate to elevation 48.30 on LEFT side

Node no.	Y coord	----- LEFT side -----					Total earth pressure kN/m2	Coeff. of subgrade reaction kN/m3
		Water press. kN/m2	Vertic -al kN/m2	Effective Active limit kN/m2	Effective Passive limit kN/m2	Earth pressure kN/m2		
8	47.70	5.89	4.91	1.65	16.92	12.66	18.55	4238
9	47.50	7.85	6.55	2.21	22.55	13.10	20.94	4238
		7.85	6.55	2.11	23.89	23.89	31.74p	12247
10	47.00	12.75	11.15	3.60	40.65	40.65	53.41p	12247
11	46.50	17.66	15.74	5.08	57.41	43.39	61.05	12247
12	46.00	22.56	20.34	6.56	74.17	46.52	69.08	12247
13	45.50	27.47	24.93	8.04	90.93	50.26	77.73	12247
14	45.00	32.37	29.53	9.53	107.69	54.48	86.85	12247
		Total>	61.90	16.50m	181.41	73.17	73.17	23345
15	44.50	Total>	71.90	19.00m	197.39	83.54	83.54	24513
16	44.17	Total>	78.41	20.63m	207.77	90.43	90.43	25271
17	43.85	Total>	84.91	22.25m	218.16	97.38	97.38	26030
18	43.65	Total>	88.91	23.25m	224.55	101.65	101.65	26497
19	43.19	Total>	98.11	25.55m	239.25	111.46	111.46	27571
20	43.00	Total>	101.91	26.50m	245.32	115.48	115.48	28015
21	42.50	Total>	111.92	29.00m	261.30	126.00	126.00	29182
22	42.00	Total>	121.92	31.50m	277.28	136.39	136.39	30349
23	41.50	Total>	131.93	34.00m	293.26	146.70	146.70	31516
24	41.13	Total>	139.43	35.87m	305.25	154.39	154.39	32392
25	40.75	Total>	146.94	37.75m	317.24	162.06	162.06	33267

Node no.	Y coord	----- RIGHT side -----					Total earth pressure kN/m2	Coeff. of subgrade reaction kN/m3
		Water press. kN/m2	Vertic -al kN/m2	Effective Active limit kN/m2	Effective Passive limit kN/m2	Earth pressure kN/m2		
1	49.75	0.00	0.00	0.00	0.00	0.00	0.00	3589
2	49.38	0.00	6.75	2.27	23.23	2.27	2.27a	3589
3	49.00	0.00	13.50	4.54	46.47	4.54	4.54a	3589
4	48.65	0.00	19.80	6.67	68.16	6.67	6.67a	3589
5	48.30	0.00	26.10	8.79	89.84	8.79	8.79a	3589
6	48.21	0.88	26.84	9.03	92.38	9.05	9.93	3589
7	47.96	3.38	28.93	9.74	99.57	10.67	14.06	3589
8	47.70	5.89	31.01	10.44	106.76	12.27	18.15	3589
9	47.50	7.85	32.65	10.99	112.40	13.50	21.35	3589
		7.85	32.65	10.53	119.08	21.67	29.52	10359
10	47.00	12.75	37.25	12.01	135.83	28.61	41.36	10359
11	46.50	17.66	41.84	13.50	152.59	35.01	52.67	10359
12	46.00	22.56	46.44	14.98	169.35	40.85	63.41	10359
13	45.50	27.47	51.03	16.46	186.11	46.17	73.64	10359
14	45.00	32.37	55.63	17.94	202.86	51.08	83.45	10359
		Total>	88.00	23.75m	207.51	79.23	79.23	19981
15	44.50	Total>	98.00	26.25m	223.49	88.92	88.92	20980
16	44.17	Total>	104.50	27.88m	233.87	95.08	95.08	21629
17	43.85	Total>	111.00	29.50m	244.26	101.21	101.21	22278
18	43.65	Total>	115.00	30.50m	250.65	104.97	104.97	22678
19	43.19	Total>	124.20	32.80m	265.34	113.65	113.65	23597
20	43.00	Total>	128.00	33.75m	271.41	117.26	117.26	23977
21	42.50	Total>	138.00	36.25m	287.39	126.82	126.82	24976
22	42.00	Total>	148.00	38.75m	303.37	136.49	136.49	25975
23	41.50	Total>	158.00	41.25m	319.34	146.23	146.23	26974
24	41.13	Total>	165.50	43.13m	331.33	153.57	153.57	27723
25	40.75	Total>	173.00	45.00m	343.31	160.93	160.93	28472

Run ID. Hampstead_Wall_4_450mm_rev_01_ULS1
Hampstead - 24-26 Redington Gardens
Wall 4, Secant-ULS1, 450 dia @ 650 - run 01

| Sheet No.
| Date: 1-10-2018
| Checked :

(continued)

Stage No.1 Excavate to elevation 48.30 on LEFT side
Note: 8.79a Soil pressure at active limit
53.41p Soil pressure at passive limit

Units: kN,m

Stage No.1 Excav. to elev. 48.30 on LEFT side

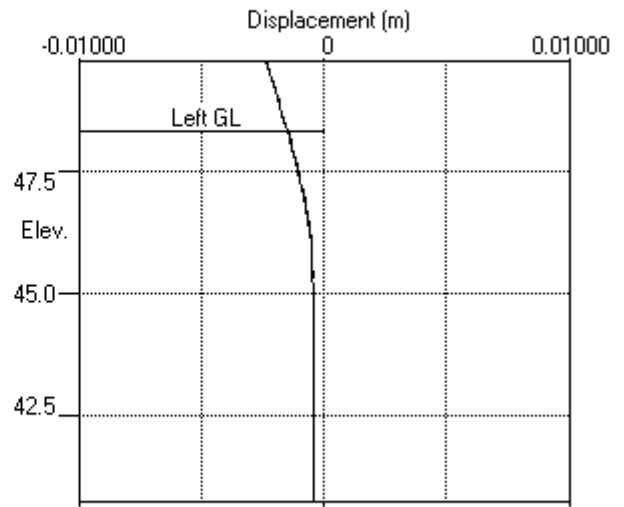
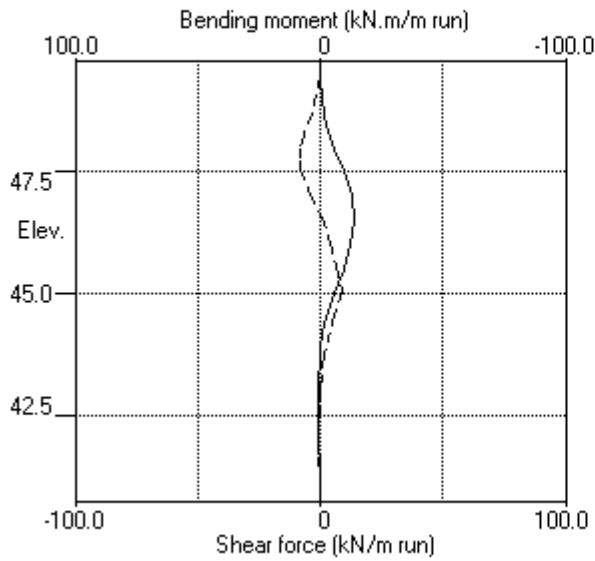

Stage No.1 Excav. to elev. 48.30 on LEFT side

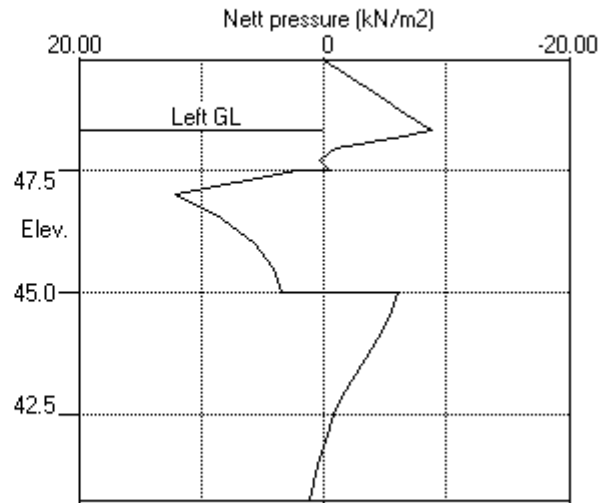
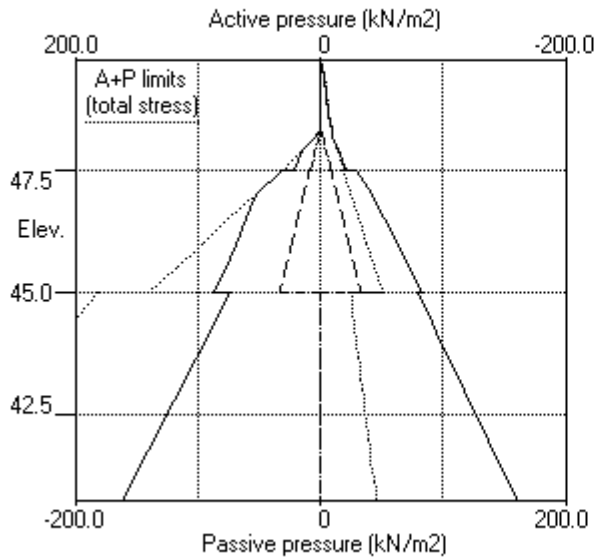

PILEDESIGNS LTD
 Program: WALLAP Version 6.06 Revision A51.B69.R54
 Licensed from GEOSOLVE
 Data filename/Run ID: Hampstead_Wall_4_450mm_rev_01_ULS1
 Hampstead - 24-26 Redington Gardens
 Wall 4, Secant-ULS1, 450 dia @ 650 - run 01

Sheet No.
 Job No. 21495
 Made by : DBS
 Date: 1-10-2018
 Checked :

Units: kN,m

Stage No. 4 Excavate to elevation 47.70 on RIGHT side

BENDING MOMENT and DISPLACEMENT ANALYSIS of Fully Embedded Wall

Analysis options

Length of wall perpendicular to section = 50.00m
 Subgrade reaction model - Boussinesq Influence coefficients
 Soil deformations are elastic until the active or passive limit is reached
 Open Tension Crack analysis - No

Rigid boundaries: Left side 50.00 from wall
 Right side 50.00 from wall

Limit State: ULS DA1 Combination 1

Calculated Bending Moments and Strut Forces are to be multiplied by a factor of 1.35 to obtain values for structural design. See summary for factored values.

Node no.	Y coord	Nett pressure kN/m2	Wall disp. m	Wall rotation rad.	Shear force kN/m	Bending moment kN.m/m	Strut forces kN/m	EI of wall kN.m2/m
1	49.75	0.00	0.001	2.57E-04	0.0	0.0		60696
2	49.38	0.00	0.001	2.57E-04	0.0	0.0		60696
3	49.00	0.00	0.001	2.57E-04	0.0	0.0		60696
4	48.65	0.00	0.001	2.57E-04	0.0	0.0		60696
5	48.30	0.00	0.001	2.57E-04	0.0	0.0		60696
6	48.21	1.14	0.001	2.57E-04	0.1	0.0		60696
7	47.96	4.66	0.001	2.57E-04	0.8	0.1		60696
8	47.70	11.15	0.001	2.55E-04	2.8	0.6		60696
9	47.50	2.94	0.001	2.52E-04	4.2	1.3		60696
		-1.90	0.001	2.52E-04	4.2	1.3		
10	47.00	2.53	0.001	2.30E-04	4.4	4.2		60696
11	46.50	-7.62	0.001	1.89E-04	3.1	5.8		60696
12	46.00	-6.29	0.001	1.36E-04	-0.4	6.9		60696
13	45.50	-4.42	0.000	8.34E-05	-3.1	5.9		60696
14	45.00	-3.32	0.000	4.30E-05	-5.0	3.9		60696
		2.74	0.000	4.30E-05	-5.0	3.9		
15	44.50	2.98	0.000	2.00E-05	-3.6	1.7		60696
16	44.17	2.80	0.000	1.36E-05	-2.6	0.7		60696
17	43.85	2.46	0.000	1.16E-05	-1.8	0.0		60696
18	43.65	2.20	0.000	1.21E-05	-1.3	-0.3		60696
19	43.19	1.55	0.000	1.58E-05	-0.4	-0.7		60696
20	43.00	1.29	0.000	1.80E-05	-0.2	-0.7		60696
21	42.50	0.64	0.000	2.38E-05	0.3	-0.7		60696
22	42.00	0.10	0.000	2.84E-05	0.5	-0.4		60696
23	41.50	-0.33	0.000	3.10E-05	0.4	-0.2		60696
24	41.13	-0.60	0.000	3.17E-05	0.3	-0.1		60696
25	40.75	-0.83	0.000	3.19E-05	0.0	-0.0		---

Node no.	Y coord	----- LEFT side -----						Total earth pressure kN/m2	Coeff. of subgrade reaction kN/m3
		----- Effective stresses -----							
		Water press. kN/m2	Vertic-al kN/m2	Active limit kN/m2	Passive limit kN/m2	Earth pressure kN/m2			
1	49.75	0.00	0.00	0.00	0.00	0.00	0.00	0.0	
2	49.38	0.00	0.00	0.00	0.00	0.00	0.00	0.0	
3	49.00	0.00	0.00	0.00	0.00	0.00	0.00	0.0	
4	48.65	0.00	0.00	0.00	0.00	0.00	0.00	0.0	
5	48.30	0.00	0.00	0.00	0.00	0.00	0.00	0.0	
		0.00	0.00	0.00	0.00	0.00	0.00	4224	
6	48.21	0.88	0.76	0.26	2.63	0.26	1.14a	4224	
7	47.96	3.38	3.78	1.27	13.01	1.27	4.66a	4224	

(continued)

Stage No.4 Excavate to elevation 47.70 on RIGHT side

Node no.	Y coord	LEFT side					Total earth pressure kN/m2	Coeff. of subgrade reaction kN/m3
		Water press. kN/m2	Vertic -al kN/m2	Effective Active limit kN/m2	Effective Passive limit kN/m2	Earth pressure kN/m2		
8	47.70	5.89	7.60	2.56	26.15	5.26	11.15	4224
9	47.50	7.85	10.48	3.53	36.06	6.78	14.63	4224
		7.85	10.48	3.38	38.20	3.38	11.23a	12207
10	47.00	12.75	17.16	5.53	62.57	24.56	37.32	12207
11	46.50	17.66	22.86	7.37	83.37	31.18	48.84	12207
12	46.00	22.56	28.04	9.04	102.26	37.08	59.64	12207
13	45.50	27.47	32.92	10.62	120.04	42.55	70.02	12207
14	45.00	32.37	37.60	12.13	137.11	47.67	80.04	12207
		Total>	69.97	16.50m	189.48	63.84	63.84	23274
15	44.50	Total>	79.93	19.00m	205.41	73.97	73.97	24437
16	44.17	Total>	86.35	20.63m	215.71	80.38	80.38	25194
17	43.85	Total>	92.74	22.25m	225.99	86.70	86.70	25950
18	43.65	Total>	96.66	23.25m	232.30	90.56	90.56	26416
19	43.19	Total>	105.66	25.55m	246.80	99.40	99.40	27486
20	43.00	Total>	109.36	26.50m	252.78	103.04	103.04	27928
21	42.50	Total>	119.11	29.00m	268.49	112.65	112.65	29092
22	42.00	Total>	128.83	31.50m	284.20	122.29	122.29	30256
23	41.50	Total>	138.56	34.00m	299.90	131.97	131.97	31419
24	41.13	Total>	145.85	35.87m	311.67	139.26	139.26	32292
25	40.75	Total>	153.14	37.75m	323.45	146.56	146.56	33165

Node no.	Y coord	RIGHT side					Total earth pressure kN/m2	Coeff. of subgrade reaction kN/m3
		Water press. kN/m2	Vertic -al kN/m2	Effective Active limit kN/m2	Effective Passive limit kN/m2	Earth pressure kN/m2		
1	49.75	0.00	0.00	0.00	0.00	0.00	0.00	0.0
2	49.38	0.00	0.00	0.00	0.00	0.00	0.00	0.0
3	49.00	0.00	0.00	0.00	0.00	0.00	0.00	0.0
4	48.65	0.00	0.00	0.00	0.00	0.00	0.00	0.0
5	48.30	0.00	0.00	0.00	0.00	0.00	0.00	0.0
6	48.21	0.00	0.00	0.00	0.00	0.00	0.00	0.0
7	47.96	0.00	0.00	0.00	0.00	0.00	0.00	0.0
8	47.70	0.00	0.00	0.00	0.00	0.00	0.00	0.0
		0.00	0.00	0.00	0.00	0.00	0.00	4413
9	47.50	0.00	3.60	1.21	12.39	11.70	11.70	4413
		0.00	3.60	1.16	13.13	13.13	13.13p	12754
10	47.00	4.90	8.20	2.64	29.89	29.89	34.79p	12754
11	46.50	9.81	12.79	4.13	46.64	46.64	56.45p	12754
12	46.00	14.71	17.39	5.61	63.40	51.22	65.93	12754
13	45.50	19.62	21.98	7.09	80.16	54.82	74.44	12754
14	45.00	24.52	26.58	8.57	96.92	58.84	83.36	12754
		Total>	51.10	13.50m	170.61	61.10	61.10	24251
15	44.50	Total>	61.10	16.00m	186.58	70.99	70.99	25464
16	44.17	Total>	67.61	17.63m	196.97	77.58	77.58	26252
17	43.85	Total>	74.11	19.25m	207.36	84.24	84.24	27040
18	43.65	Total>	78.11	20.25m	213.75	88.36	88.36	27525
19	43.19	Total>	87.31	22.55m	228.45	97.85	97.85	28641
20	43.00	Total>	91.11	23.50m	234.52	101.76	101.76	29102
21	42.50	Total>	101.12	26.00m	250.50	112.01	112.01	30314
22	42.00	Total>	111.12	28.50m	266.48	122.18	122.18	31527
23	41.50	Total>	121.13	31.00m	282.47	132.30	132.30	32739
24	41.13	Total>	128.63	32.88m	294.45	139.85	139.85	33649
25	40.75	Total>	136.14	34.75m	306.44	147.39	147.39	34558

Run ID. Hampstead_Wall_4_450mm_rev_01_ULS1
Hampstead - 24-26 Redington Gardens
Wall 4, Secant-ULS1, 450 dia @ 650 - run 01

| Sheet No.
| Date: 1-10-2018
| Checked :

(continued)

Stage No.4 Excavate to elevation 47.70 on RIGHT side
Note: 11.23a Soil pressure at active limit
56.45p Soil pressure at passive limit

Units: kN,m

Stage No.4 Excav. to elev. 47.70 on RIGHT side

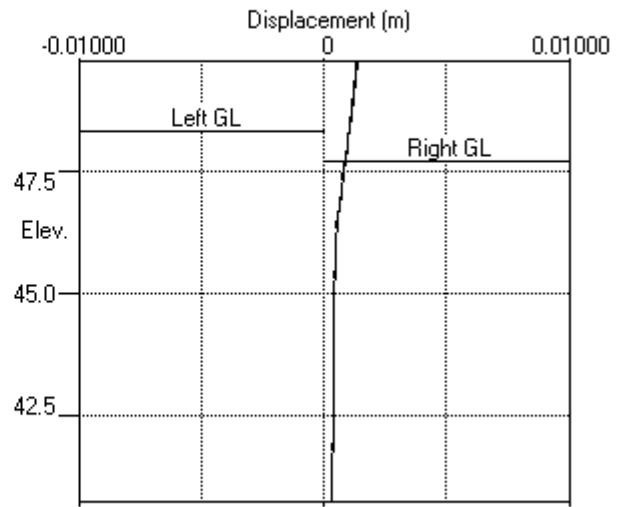
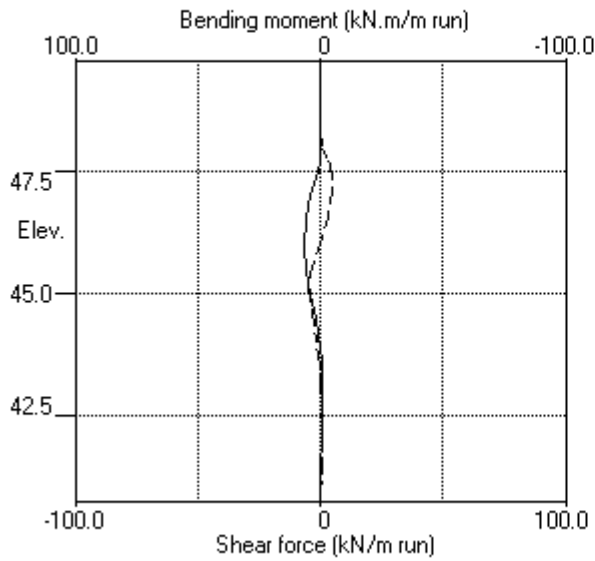

Stage No.4 Excav. to elev. 47.70 on RIGHT side

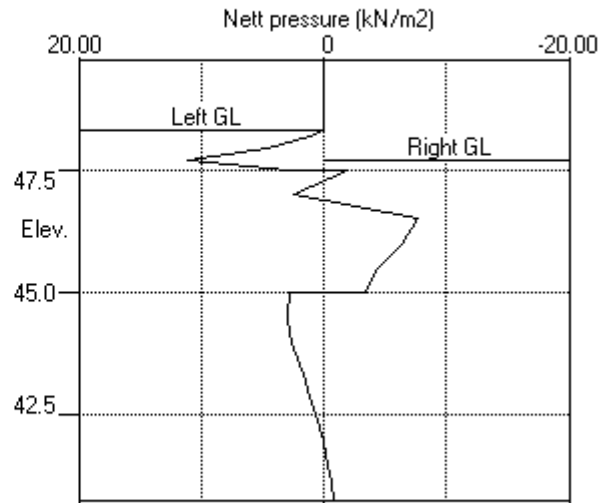
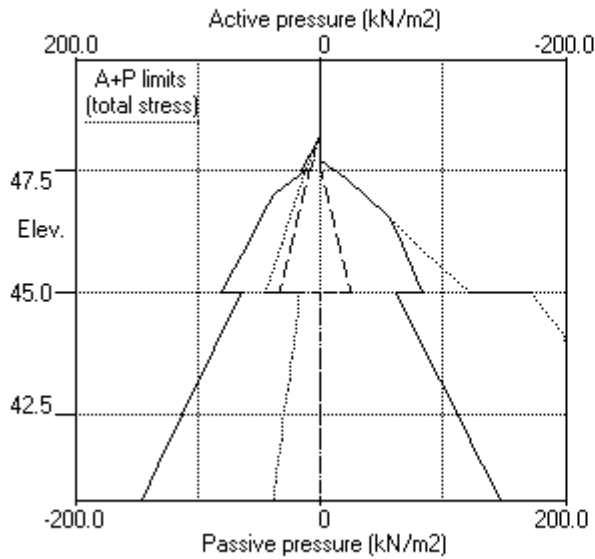

PILEDESIGNS LTD
 Program: WALLAP Version 6.06 Revision A51.B69.R54
 Licensed from GEOSOLVE
 Data filename/Run ID: Hampstead_Wall_4_450mm_rev_01_ULS1
 Hampstead - 24-26 Redington Gardens
 Wall 4, Secant-ULS1, 450 dia @ 650 - run 01

Sheet No.
 Job No. 21495
 Made by : DBS
 Date: 1-10-2018
 Checked :

Units: kN,m

Stage No. 7 Excavate to elevation 43.19 on RIGHT side

BENDING MOMENT and DISPLACEMENT ANALYSIS of Fully Embedded Wall

Analysis options

Length of wall perpendicular to section = 50.00m
 Subgrade reaction model - Boussinesq Influence coefficients
 Soil deformations are elastic until the active or passive limit is reached
 Open Tension Crack analysis - No

Rigid boundaries: Left side 50.00 from wall
 Right side 50.00 from wall

Limit State: ULS DA1 Combination 1

Calculated Bending Moments and Strut Forces are to be multiplied by a factor of 1.35 to obtain values for structural design. See summary for factored values.

Node no.	Y coord	Nett pressure kN/m2	Wall disp. m	Wall rotation rad.	Shear force kN/m	Bending moment kN.m/m	Strut forces kN/m	EI of wall kN.m2/m
1	49.75	0.00	-0.003	-2.91E-03	0.0	0.0		60696
2	49.38	0.00	-0.002	-2.91E-03	0.0	0.0		60696
3	49.00	0.00	-0.001	-2.91E-03	0.0	0.0		60696
4	48.65	0.00	-0.000	-2.91E-03	0.0	0.0		60696
5	48.30	0.00	0.001	-2.91E-03	0.0	0.0		60696
6	48.21	1.14	0.001	-2.91E-03	0.1	0.0	51.2	60696
		1.14	0.001	-2.91E-03	-51.1	0.0		
7	47.96	4.66	0.002	-2.89E-03	-50.4	-13.0		60696
8	47.70	8.44	0.003	-2.81E-03	-48.7	-25.6		60696
9	47.50	11.37	0.003	-2.71E-03	-46.7	-35.1		60696
		11.23	0.003	-2.71E-03	-46.7	-35.1		
10	47.00	18.29	0.004	-2.33E-03	-39.4	-55.8		60696
11	46.50	25.03	0.005	-1.80E-03	-28.5	-73.3		60696
12	46.00	31.61	0.006	-1.15E-03	-14.4	-83.7		60696
13	45.50	38.09	0.007	-4.55E-04	3.0	-86.8		60696
14	45.00	44.50	0.007	2.32E-04	23.7	-80.3		60696
		16.50	0.007	2.32E-04	23.7	-80.3		
15	44.50	19.00	0.006	8.36E-04	32.6	-66.3		60696
16	44.17	20.63	0.006	1.16E-03	39.0	-54.7		60696
17	43.85	22.25	0.006	1.41E-03	46.0	-41.0		60696
18	43.65	23.25	0.005	1.53E-03	50.5	-31.3		60696
19	43.19	35.08	0.005	1.66E-03	63.9	-3.0		60696
		-97.29	0.005	1.66E-03	63.9	-3.0		
20	43.00	-86.30	0.004	1.65E-03	46.5	7.4		60696
21	42.50	-56.67	0.003	1.54E-03	10.8	19.8		60696
22	42.00	-27.54	0.003	1.39E-03	-10.3	18.1		60696
23	41.50	0.80	0.002	1.27E-03	-17.0	9.5		60696
24	41.13	22.24	0.002	1.23E-03	-12.7	3.2		60696
25	40.75	45.27	0.001	1.22E-03	0.0	0.0		---
At elev. 48.21		Strut force =		51.2 kN/strut =		51.2 kN/m run		

Node no.	Y coord	LEFT side					Total earth pressure kN/m2	Coeff. of subgrade reaction kN/m3
		Water press. kN/m2	Vertical kN/m2	Effective Active limit kN/m2	Effective Passive limit kN/m2	Earth pressure kN/m2		
1	49.75	0.00	0.00	0.00	0.00	0.00	0.0	
2	49.38	0.00	0.00	0.00	0.00	0.00	0.0	
3	49.00	0.00	0.00	0.00	0.00	0.00	0.0	
4	48.65	0.00	0.00	0.00	0.00	0.00	0.0	
5	48.30	0.00	0.00	0.00	0.00	0.00	0.0	
		0.00	0.00	0.00	0.00	0.00	71606	

(continued)

Stage No.7 Excavate to elevation 43.19 on RIGHT side

Node no.	Y coord	LEFT side					Total earth pressure kN/m2	Coeff. of subgrade reaction kN/m3
		Water press. kN/m2	Vertic -al kN/m2	Effective Active limit kN/m2	Effective Passive limit kN/m2	Earth pressure kN/m2		
6	48.21	0.88	0.76	0.26	2.63	0.26	1.14a	2255
7	47.96	3.38	3.78	1.27	13.01	1.27	4.66a	2255
8	47.70	5.89	7.60	2.56	26.15	2.56	8.44a	2255
9	47.50	7.85	10.48	3.53	36.06	3.53	11.37a	2255
		7.85	10.48	3.38	38.20	3.38	11.23a	6476
10	47.00	12.75	17.16	5.53	62.57	5.53	18.29a	6476
11	46.50	17.66	22.86	7.37	83.37	7.37	25.03a	6476
12	46.00	22.56	28.04	9.04	102.26	9.04	31.61a	6476
13	45.50	27.47	32.92	10.62	120.04	10.62	38.09a	6476
14	45.00	32.37	37.60	12.13	137.11	12.13	44.50a	6476
		Total>	69.97	16.50m	189.48	16.50	16.50a	13142
15	44.50	Total>	79.93	19.00m	205.41	19.00	19.00a	13799
16	44.17	Total>	86.35	20.63m	215.71	20.63	20.63a	14226
17	43.85	Total>	92.74	22.25m	225.99	22.25	22.25a	14654
18	43.65	Total>	96.66	23.25m	232.30	23.25	23.25a	14916
19	43.19	Total>	105.66	25.55m	246.80	35.08	35.08	15521
20	43.00	Total>	109.36	26.50m	252.78	42.66	42.66	15771
21	42.50	Total>	119.11	29.00m	268.49	62.87	62.87	16428
22	42.00	Total>	128.83	31.50m	284.20	82.89	82.89	17085
23	41.50	Total>	138.56	34.00m	299.90	102.62	102.62	17742
24	41.13	Total>	145.85	35.87m	311.67	117.48	117.48	18235
25	40.75	Total>	153.14	37.75m	323.45	133.01	133.01	18728

Node no.	Y coord	RIGHT side					Total earth pressure kN/m2	Coeff. of subgrade reaction kN/m3
		Water press. kN/m2	Vertic -al kN/m2	Effective Active limit kN/m2	Effective Passive limit kN/m2	Earth pressure kN/m2		
1	49.75	0.00	0.00	0.00	0.00	0.00	0.00	0.0
2	49.38	0.00	0.00	0.00	0.00	0.00	0.00	0.0
3	49.00	0.00	0.00	0.00	0.00	0.00	0.00	0.0
4	48.65	0.00	0.00	0.00	0.00	0.00	0.00	0.0
5	48.30	0.00	0.00	0.00	0.00	0.00	0.00	0.0
6	48.21	0.00	0.00	0.00	0.00	0.00	0.00	0.0
7	47.96	0.00	0.00	0.00	0.00	0.00	0.00	0.0
8	47.70	0.00	0.00	0.00	0.00	0.00	0.00	0.0
9	47.50	0.00	0.00	0.00	0.00	0.00	0.00	0.0
10	47.00	0.00	0.00	0.00	0.00	0.00	0.00	0.0
11	46.50	0.00	0.00	0.00	0.00	0.00	0.00	0.0
12	46.00	0.00	0.00	0.00	0.00	0.00	0.00	0.0
13	45.50	0.00	0.00	0.00	0.00	0.00	0.00	0.0
14	45.00	0.00	0.00	0.00	0.00	0.00	0.00	0.0
15	44.50	0.00	0.00	0.00	0.00	0.00	0.00	0.0
16	44.17	0.00	0.00	0.00	0.00	0.00	0.00	0.0
17	43.85	0.00	0.00	0.00	0.00	0.00	0.00	0.0
18	43.65	0.00	0.00	0.00	0.00	0.00	0.00	0.0
19	43.19	0.00	0.00	0.00	0.00	0.00	0.00	0.0
		Total>	0.00	0.00	141.13	132.37	132.37	29410
20	43.00	Total>	3.80	0.95m	147.20	128.95	128.95	29884
21	42.50	Total>	13.80	3.45m	163.17	119.54	119.54	31129
22	42.00	Total>	23.80	5.95m	179.15	110.43	110.43	32374
23	41.50	Total>	33.80	8.45m	195.13	101.82	101.82	33619
24	41.13	Total>	41.30	10.33m	207.11	95.24	95.24	34553
25	40.75	Total>	48.81	12.20m	219.10	87.75	87.75	35487

Run ID. Hampstead_Wall_4_450mm_rev_01_ULS1
Hampstead - 24-26 Redington Gardens
Wall 4, Secant-ULS1, 450 dia @ 650 - run 01

| Sheet No.
| Date: 1-10-2018
| Checked :

(continued)

Stage No.7 Excavate to elevation 43.19 on RIGHT side
Note: 23.25a Soil pressure at active limit
123.45p Soil pressure at passive limit

Units: kN,m

Stage No.7 Excav. to elev. 43.19 on RIGHT side

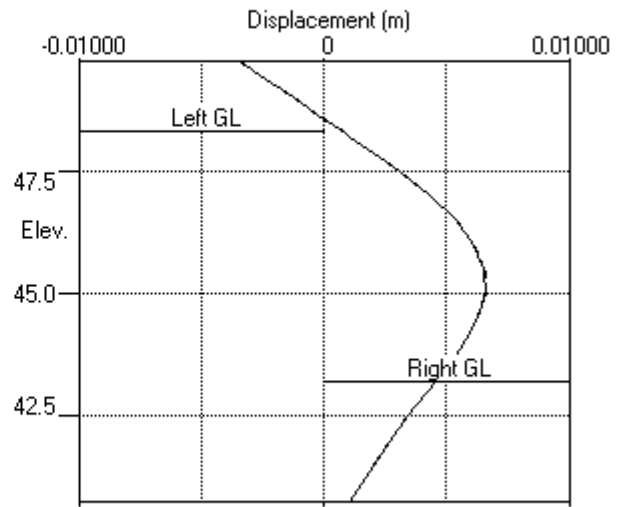
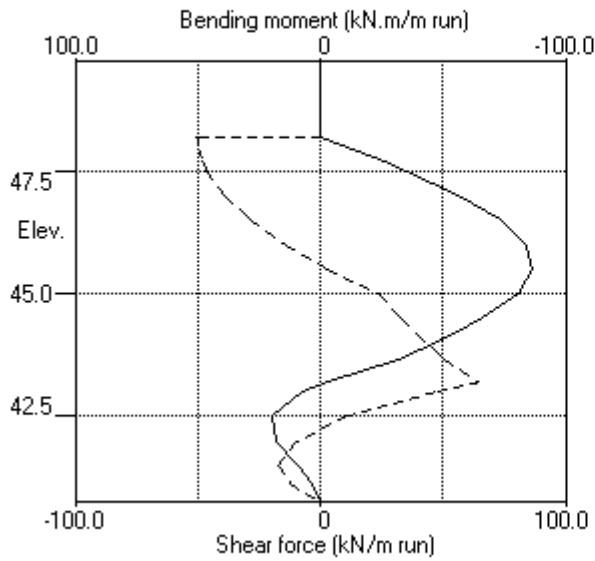

Stage No.7 Excav. to elev. 43.19 on RIGHT side

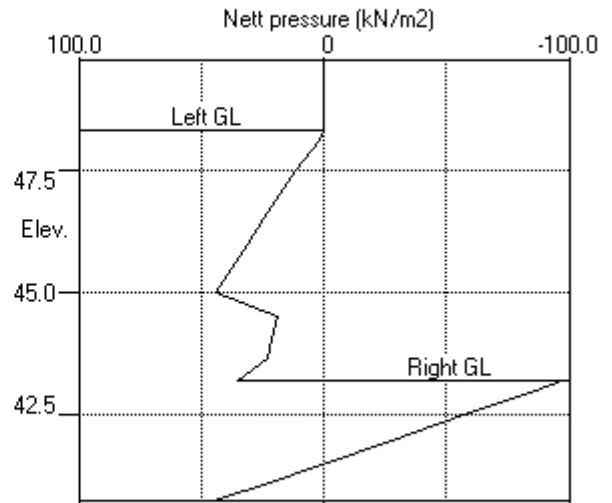
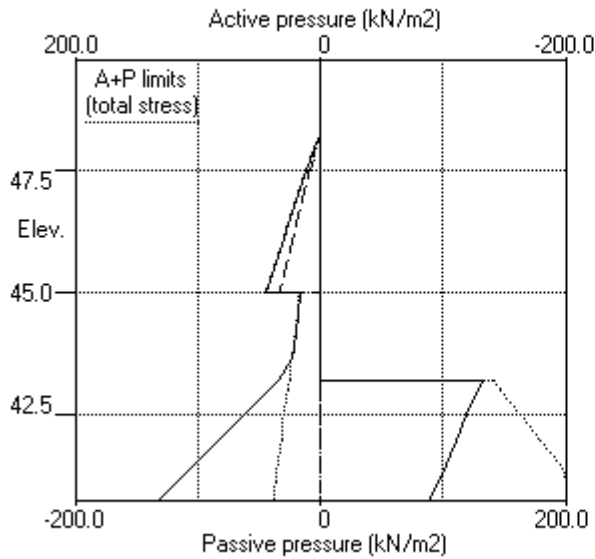

PILEDESIGNS LTD
 Program: WALLAP Version 6.06 Revision A51.B69.R54
 Licensed from GEOSOLVE
 Data filename/Run ID: Hampstead_Wall_4_450mm_rev_01_ULS1
 Hampstead - 24-26 Redington Gardens
 Wall 4, Secant-ULS1, 450 dia @ 650 - run 01

Sheet No.
 Job No. 21495
 Made by : DBS
 Date: 1-10-2018
 Checked :

Units: kN,m

Stage No. 8 Fill to elevation 43.65 on RIGHT side with soil type 1

BENDING MOMENT and DISPLACEMENT ANALYSIS of Fully Embedded Wall

Analysis options

Length of wall perpendicular to section = 50.00m
 Subgrade reaction model - Boussinesq Influence coefficients
 Soil deformations are elastic until the active or passive limit is reached
 Open Tension Crack analysis - No

Rigid boundaries: Left side 50.00 from wall
 Right side 50.00 from wall

Limit State: ULS DA1 Combination 1

Calculated Bending Moments and Strut Forces are to be multiplied by a factor of 1.35 to obtain values for structural design. See summary for factored values.

Node no.	Y coord	Nett pressure kN/m2	Wall disp. m	Wall rotation rad.	Shear force kN/m	Bending moment kN.m/m	Strut forces kN/m	EI of wall kN.m2/m
1	49.75	0.00	-0.003	-2.91E-03	0.0	0.0		60696
2	49.38	0.00	-0.002	-2.91E-03	0.0	0.0		60696
3	49.00	0.00	-0.001	-2.91E-03	0.0	0.0		60696
4	48.65	0.00	-0.000	-2.91E-03	0.0	0.0		60696
5	48.30	0.00	0.001	-2.91E-03	0.0	0.0		60696
6	48.21	1.14	0.001	-2.91E-03	0.1	0.0	51.6	60696
		1.14	0.001	-2.91E-03	-51.5	0.0		
7	47.96	4.66	0.002	-2.89E-03	-50.8	-13.0		60696
8	47.70	8.45	0.003	-2.80E-03	-49.1	-25.8		60696
9	47.50	11.38	0.003	-2.70E-03	-47.1	-35.3		60696
		11.24	0.003	-2.70E-03	-47.1	-35.3		
10	47.00	18.31	0.004	-2.33E-03	-39.7	-56.3		60696
11	46.50	25.09	0.005	-1.79E-03	-28.9	-74.0		60696
12	46.00	31.72	0.006	-1.14E-03	-14.7	-84.5		60696
13	45.50	38.29	0.007	-4.32E-04	2.8	-87.7		60696
14	45.00	44.82	0.007	2.64E-04	23.6	-81.3		60696
		17.12	0.007	2.64E-04	23.6	-81.3		
15	44.50	19.97	0.006	8.76E-04	32.9	-67.3		60696
16	44.17	21.87	0.006	1.20E-03	39.7	-55.6		60696
17	43.85	23.82	0.005	1.46E-03	47.1	-41.5		60696
18	43.65	25.04	0.005	1.58E-03	52.0	-31.6		60696
19	43.19	34.61	0.004	1.71E-03	65.7	-2.6		60696
		-100.62	0.004	1.71E-03	65.7	-2.6		
20	43.00	-89.18	0.004	1.70E-03	47.7	8.1		60696
21	42.50	-58.42	0.003	1.58E-03	10.8	20.8		60696
22	42.00	-28.25	0.002	1.42E-03	-10.9	18.9		60696
23	41.50	1.05	0.002	1.30E-03	-17.7	9.9		60696
24	41.13	23.20	0.001	1.26E-03	-13.2	3.3		60696
25	40.75	46.94	0.001	1.25E-03	0.0	0.0		---

At elev. 48.21 Strut force = 51.6 kN/strut = 51.6 kN/m run

Node no.	Y coord	LEFT side					Total earth pressure kN/m2	Coeff. of subgrade reaction kN/m3
		Water press. kN/m2	Vertical limit kN/m2	Active limit kN/m2	Passive limit kN/m2	Earth pressure kN/m2		
1	49.75	0.00	0.00	0.00	0.00	0.00	0.0	
2	49.38	0.00	0.00	0.00	0.00	0.00	0.0	
3	49.00	0.00	0.00	0.00	0.00	0.00	0.0	
4	48.65	0.00	0.00	0.00	0.00	0.00	0.0	
5	48.30	0.00	0.00	0.00	0.00	0.00	0.0	
		0.00	0.00	0.00	0.00	0.00	20888	

(continued)

Stage No.8 Fill to elevation 43.65 on RIGHT side with soil type 1

Node no.	Y coord	LEFT side					Total earth pressure kN/m2	Coeff. of subgrade reaction kN/m3
		Water press. kN/m2	Vertic -al kN/m2	Effective Active limit kN/m2	Effective Passive limit kN/m2	Earth pressure kN/m2		
6	48.21	0.88	0.76	0.26	2.63	0.26	1.14a	20888
7	47.96	3.38	3.78	1.27	13.01	1.27	4.66a	2991
8	47.70	5.89	7.60	2.56	26.15	2.56	8.45a	2991
9	47.50	7.85	10.48	3.53	36.06	3.53	11.38a	2991
		7.85	10.48	3.38	38.20	3.39	11.24	8619
10	47.00	12.75	17.16	5.53	62.57	5.56	18.31	8619
11	46.50	17.66	22.86	7.37	83.37	7.43	25.09	8619
12	46.00	22.56	28.04	9.04	102.26	9.16	31.72	8619
13	45.50	27.47	32.92	10.62	120.04	10.82	38.29	8619
14	45.00	32.37	37.60	12.13	137.11	12.45	44.82	8619
		Total>	69.97	16.50m	189.48	17.12	17.12	16891
15	44.50	Total>	79.93	19.00m	205.41	19.97	19.97	17736
16	44.17	Total>	86.35	20.63m	215.71	21.87	21.87	18285
17	43.85	Total>	92.74	22.25m	225.99	23.82	23.82	18834
18	43.65	Total>	96.66	23.25m	232.30	25.04	25.04	19172
19	43.19	Total>	105.66	25.55m	246.80	37.40	37.40	19949
20	43.00	Total>	109.36	26.50m	252.78	45.19	45.19	20270
21	42.50	Total>	119.11	29.00m	268.49	65.98	65.98	21114
22	42.00	Total>	128.83	31.50m	284.20	86.51	86.51	21959
23	41.50	Total>	138.56	34.00m	299.90	106.72	106.72	22803
24	41.13	Total>	145.85	35.87m	311.67	121.94	121.94	23437
25	40.75	Total>	153.14	37.75m	323.45	137.83	137.83	24070

Node no.	Y coord	RIGHT side					Total earth pressure kN/m2	Coeff. of subgrade reaction kN/m3
		Water press. kN/m2	Vertic -al kN/m2	Effective Active limit kN/m2	Effective Passive limit kN/m2	Earth pressure kN/m2		
1	49.75	0.00	0.00	0.00	0.00	0.00	0.00	0.0
2	49.38	0.00	0.00	0.00	0.00	0.00	0.00	0.0
3	49.00	0.00	0.00	0.00	0.00	0.00	0.00	0.0
4	48.65	0.00	0.00	0.00	0.00	0.00	0.00	0.0
5	48.30	0.00	0.00	0.00	0.00	0.00	0.00	0.0
6	48.21	0.00	0.00	0.00	0.00	0.00	0.00	0.0
7	47.96	0.00	0.00	0.00	0.00	0.00	0.00	0.0
8	47.70	0.00	0.00	0.00	0.00	0.00	0.00	0.0
9	47.50	0.00	0.00	0.00	0.00	0.00	0.00	0.0
10	47.00	0.00	0.00	0.00	0.00	0.00	0.00	0.0
11	46.50	0.00	0.00	0.00	0.00	0.00	0.00	0.0
12	46.00	0.00	0.00	0.00	0.00	0.00	0.00	0.0
13	45.50	0.00	0.00	0.00	0.00	0.00	0.00	0.0
14	45.00	0.00	0.00	0.00	0.00	0.00	0.00	0.0
15	44.50	0.00	0.00	0.00	0.00	0.00	0.00	0.0
16	44.17	0.00	0.00	0.00	0.00	0.00	0.00	0.0
17	43.85	0.00	0.00	0.00	0.00	0.00	0.00	0.0
18	43.65	0.00	0.00	0.00	0.00	0.00	0.00	0.0
		0.00	0.00	0.00	0.00	0.00	0.00	2991
19	43.19	0.00	8.28	2.79	28.50	2.79	2.79a	2991
		Total>	8.28	2.30m	149.41	138.01	138.01	19949
20	43.00	Total>	12.08	3.25m	155.48	134.37	134.37	20270
21	42.50	Total>	22.08	5.75m	171.46	124.40	124.40	21114
22	42.00	Total>	32.08	8.25m	187.43	114.76	114.76	21959
23	41.50	Total>	42.08	10.75m	203.41	105.67	105.67	22803
24	41.13	Total>	49.59	12.63m	215.40	98.74	98.74	23437

Run ID. Hampstead_Wall_4_450mm_rev_01_ULS1
 Hampstead - 24-26 Redington Gardens
 Wall 4, Secant-ULS1, 450 dia @ 650 - run 01

| Sheet No.
 | Date: 1-10-2018
 | Checked :

(continued)

Stage No.8 Fill to elevation 43.65 on RIGHT side with soil type 1

Node no.	Y coord	----- RIGHT side -----					Total earth pressure	Coeff. of subgrade reaction
		Water press. kN/m2	Vertic -al kN/m2	Effective Active limit kN/m2	Effective Passive limit kN/m2	Earth pressure kN/m2		
25	40.75	Total>	57.09	14.50m	227.38	90.89	90.89	24070

Note: 2.79a Soil pressure at active limit
 123.45p Soil pressure at passive limit

Units: kN,m

Stage No.8 Fill to elev. 43.65 on RIGHT side

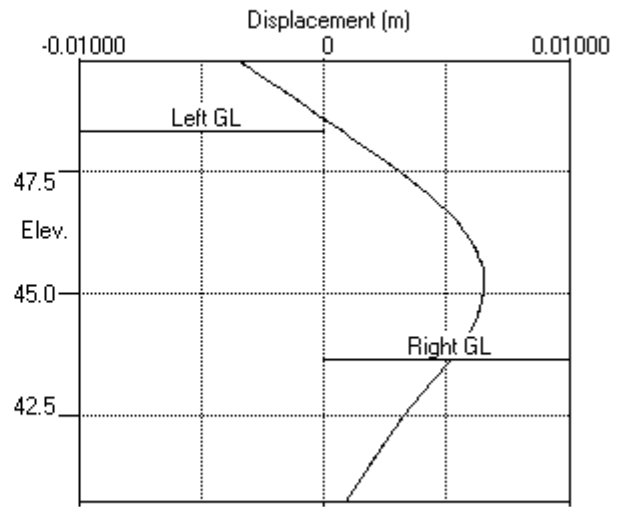
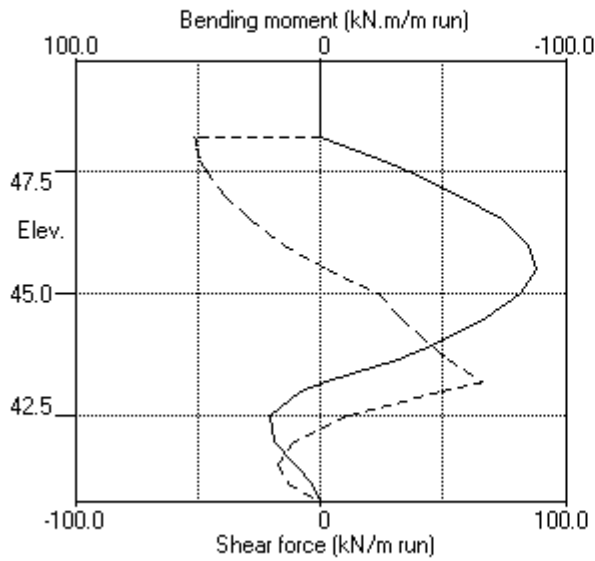

Stage No.8 Fill to elev. 43.65 on RIGHT side

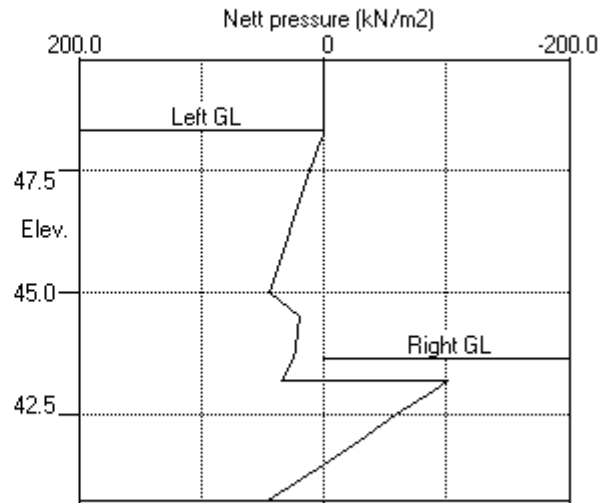
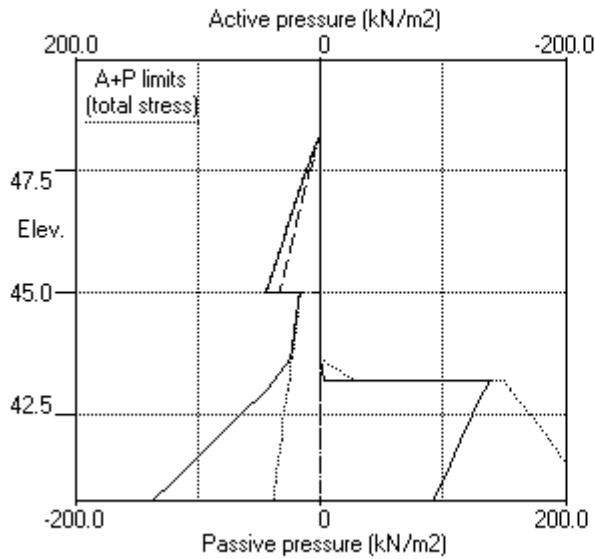

PILEDESIGNS LTD
 Program: WALLAP Version 6.06 Revision A51.B69.R54
 Licensed from GEOSOLVE
 Data filename/Run ID: Hampstead_Wall_4_450mm_rev_01_ULS1
 Hampstead - 24-26 Redington Gardens
 Wall 4, Secant-ULS1, 450 dia @ 650 - run 01

Sheet No.
 Job No. 21495
 Made by : DBS
 Date: 1-10-2018
 Checked :

Units: kN,m

Stage No. 10 Change EI of wall to 43355 kN.m2/m run
 Yield moment not defined
 Allow wall to relax with new modulus value

BENDING MOMENT and DISPLACEMENT ANALYSIS of Fully Embedded Wall

Analysis options

Length of wall perpendicular to section = 50.00m
 Subgrade reaction model - Boussinesq Influence coefficients
 Soil deformations are elastic until the active or passive limit is reached
 Open Tension Crack analysis - No

Rigid boundaries: Left side 50.00 from wall
 Right side 50.00 from wall

Limit State: ULS DA1 Combination 1

Calculated Bending Moments and Strut Forces are to be multiplied by a factor of 1.35 to obtain values for structural design. See summary for factored values.

Node no.	Y coord	Nett pressure kN/m2	Wall disp. m	Wall rotation rad.	Shear force kN/m	Bending moment kN.m/m	Strut forces kN/m	EI of wall kN.m2/m
1	49.75	0.00	-0.004	-3.33E-03	0.0	0.0		43355
2	49.38	0.00	-0.003	-3.33E-03	0.0	0.0		43355
3	49.00	0.00	-0.002	-3.33E-03	0.0	0.0		43355
4	48.65	0.00	-0.000	-3.33E-03	0.0	0.0		43355
5	48.30	0.00	0.001	-3.33E-03	0.0	0.0		43355
6	48.21	1.38	0.001	-3.33E-03	0.1	0.0	46.7	43355
		1.38	0.001	-3.33E-03	-46.7	0.0		
7	47.96	4.66	0.002	-3.29E-03	-45.9	-12.1		43355
8	47.70	8.44	0.003	-3.19E-03	-44.2	-23.8		43355
9	47.50	11.37	0.003	-3.06E-03	-42.2	-32.7		43355
		11.23	0.003	-3.06E-03	-42.2	-32.7		
10	47.00	18.29	0.005	-2.59E-03	-34.9	-51.7		43355
11	46.50	25.03	0.006	-1.92E-03	-24.0	-67.5		43355
12	46.00	31.61	0.007	-1.11E-03	-9.9	-76.2		43355
13	45.50	38.09	0.007	-2.62E-04	7.5	-77.5		43355
14	45.00	44.50	0.007	5.47E-04	28.2	-69.3		43355
		16.50	0.007	5.47E-04	28.2	-69.3		
15	44.50	19.00	0.006	1.21E-03	37.1	-53.6		43355
16	44.17	20.63	0.006	1.53E-03	43.5	-40.8		43355
17	43.85	23.42	0.005	1.75E-03	50.7	-25.8	18.1	43355
		23.42	0.005	1.75E-03	32.6	-25.8		
18	43.65	25.79	0.005	1.83E-03	37.5	-18.2		43355
19	43.19	37.67	0.004	1.86E-03	52.1	5.8		43355
		-94.50	0.004	1.86E-03	52.1	5.8		
20	43.00	-81.73	0.004	1.81E-03	35.4	14.5		43355
21	42.50	-49.33	0.003	1.58E-03	2.6	23.1		43355
22	42.00	-20.08	0.002	1.33E-03	-14.7	18.9		43355
23	41.50	6.46	0.002	1.17E-03	-18.1	9.2		43355
24	41.13	25.86	0.001	1.12E-03	-12.1	2.8		43355
25	40.75	38.51	0.001	1.11E-03	-0.0	0.0		---
At elev. 48.21		Strut force =		46.7 kN/strut =		46.7 kN/m run		
At elev. 43.85		Strut force =		18.1 kN/strut =		18.1 kN/m run		

(continued)

Stage No.10 Change EI of wall to 43355 kN.m2/m run
 Yield moment not defined
 Allow wall to relax with new modulus value

Node no.	Y coord	RIGHT side						
		Water press. kN/m2	Vertic -al kN/m2	Effective Active limit kN/m2	Effective Passive limit kN/m2	Earth pressure kN/m2	Total earth pressure kN/m2	Coeff. of subgrade reaction kN/m3
19	43.19	0.00	8.28	2.79	28.50	2.79	2.79a	3689
		Total>	8.28	2.30m	149.41	134.95	134.95	24210
20	43.00	Total>	12.08	3.25m	155.48	130.65	130.65	24599
21	42.50	Total>	22.08	5.75m	171.46	119.85	119.85	25624
22	42.00	Total>	32.08	8.25m	187.43	110.68	110.68	26649
23	41.50	Total>	42.08	10.75m	203.41	102.97	102.97	27674
24	41.13	Total>	49.59	12.63m	215.40	97.41	97.41	28443
25	40.75	Total>	57.09	14.50m	227.38	95.10	95.10	713980

Note: 2.79a Soil pressure at active limit
 123.45p Soil pressure at passive limit

Units: kN,m

Stage No.10 Change EI of wall to 43355kN.m²/m run

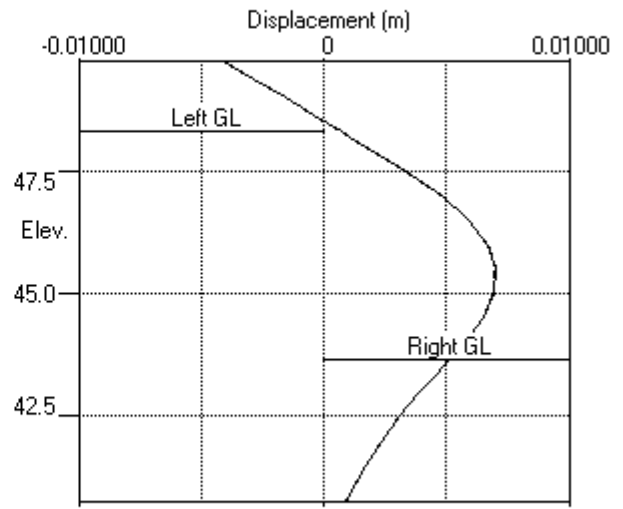
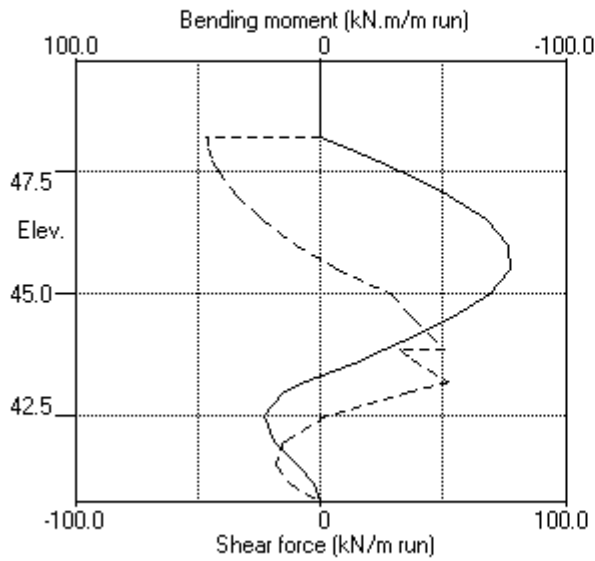

Stage No.10 Change EI of wall to 43355kN.m²/m run

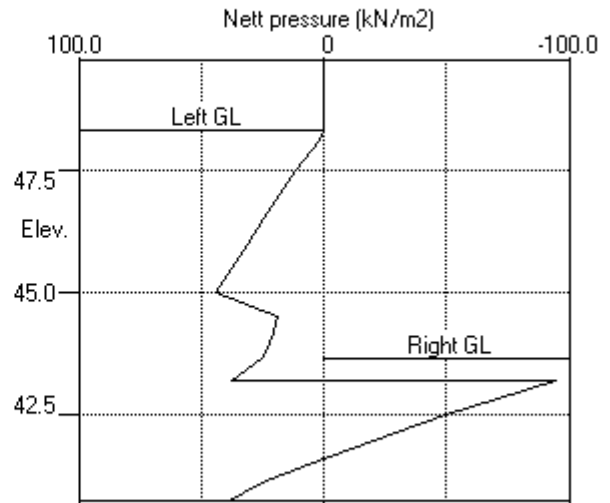
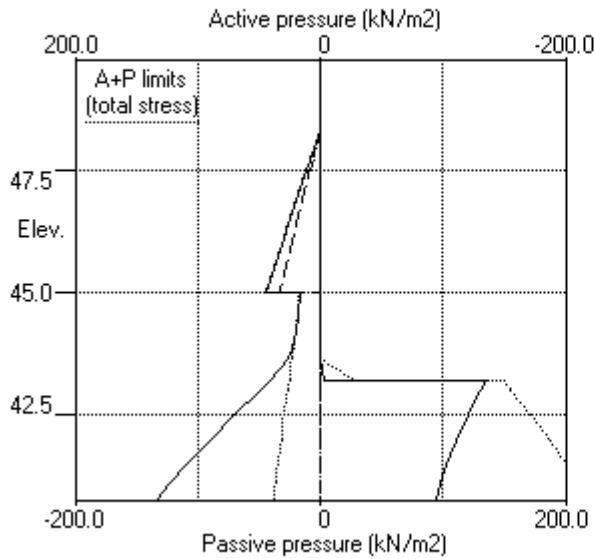

PILEDESIGNS LTD
 Program: WALLAP Version 6.06 Revision A51.B69.R54
 Licensed from GEOSOLVE
 Data filename/Run ID: Hampstead_Wall_4_450mm_rev_01_ULS1
 Hampstead - 24-26 Redington Gardens
 Wall 4, Secant-ULS1, 450 dia @ 650 - run 01

Sheet No.
 Job No. 21495
 Made by : DBS
 Date: 1-10-2018
 Checked :

Units: kN,m

Stage No. 11 Change properties of soil type 3 to soil type 4
 Ko pressures will not be reset

BENDING MOMENT and DISPLACEMENT ANALYSIS of Fully Embedded Wall

Analysis options

Length of wall perpendicular to section = 50.00m
 Subgrade reaction model - Boussinesq Influence coefficients
 Soil deformations are elastic until the active or passive limit is reached
 Open Tension Crack analysis - No

Rigid boundaries: Left side 50.00 from wall
 Right side 50.00 from wall

Limit State: ULS DA1 Combination 1

Calculated Bending Moments and Strut Forces are to be multiplied by a factor
 of 1.35 to obtain values for structural design. See summary for factored values.

Node no.	Y coord	Nett pressure kN/m ²	Wall disp. m	Wall rotation rad.	Shear force kN/m	Bending moment kN.m/m	Strut forces kN/m	EI of wall kN.m ² /m
1	49.75	0.00	-0.004	-3.17E-03	0.0	0.0		43355
2	49.38	0.00	-0.003	-3.17E-03	0.0	0.0		43355
3	49.00	0.00	-0.001	-3.17E-03	0.0	0.0		43355
4	48.65	0.00	-0.000	-3.17E-03	0.0	0.0		43355
5	48.30	0.00	0.001	-3.17E-03	0.0	0.0		43355
6	48.21	1.39	0.001	-3.17E-03	0.1	0.0	45.2	43355
		1.39	0.001	-3.17E-03	-45.1	0.0		
7	47.96	4.78	0.002	-3.13E-03	-44.3	-11.7		43355
8	47.70	8.69	0.003	-3.03E-03	-42.6	-23.0		43355
9	47.50	11.71	0.003	-2.91E-03	-40.6	-31.5		43355
		12.20	0.003	-2.91E-03	-40.6	-31.5		
10	47.00	19.87	0.005	-2.45E-03	-32.6	-49.7		43355
11	46.50	27.12	0.006	-1.82E-03	-20.8	-64.1		43355
12	46.00	34.04	0.006	-1.06E-03	-5.5	-70.9		43355
13	45.50	40.58	0.007	-2.85E-04	13.1	-69.8		43355
14	45.00	46.68	0.007	4.16E-04	34.9	-58.5		43355
		45.58	0.007	4.16E-04	34.9	-58.5		
15	44.50	52.26	0.006	9.16E-04	59.4	-35.6		43355
16	44.17	56.58	0.006	1.07E-03	77.1	-13.7		43355
17	43.85	60.90	0.006	1.03E-03	96.2	14.1	153.8	43355
		60.90	0.006	1.03E-03	-57.7	14.1		
18	43.65	63.55	0.005	9.74E-04	-45.2	4.4		43355
19	43.19	64.46	0.005	9.50E-04	-15.8	-6.0		43355
		42.70	0.005	9.50E-04	-15.8	-6.0		
20	43.00	32.85	0.005	9.71E-04	-8.6	-7.8		43355
21	42.50	17.98	0.004	1.05E-03	4.1	-8.8		43355
22	42.00	3.09	0.004	1.13E-03	9.4	-5.7		43355
23	41.50	-11.79	0.003	1.17E-03	7.2	-2.2		43355
24	41.13	-12.99	0.003	1.18E-03	2.6	0.1		43355
25	40.75	-0.67	0.002	1.18E-03	-0.0	0.0		---
At elev. 48.21		Strut force =		45.2 kN/strut =	45.2 kN/m run			
At elev. 43.85		Strut force =		153.8 kN/strut =	153.8 kN/m run			

(continued)

Stage No.11 Change properties of soil type 3 to soil type 4
 Ko pressures will not be reset

Node no.	Y coord	----- RIGHT side -----						Total earth pressure	Coeff. of subgrade reaction
		Water press.	Vertical	Effective Active limit	Effective Passive limit	Earth pressure	Earth pressure		
		kN/m2	kN/m2	kN/m2	kN/m2	kN/m2	kN/m2	kN/m3	
19	43.19	0.00	8.28	2.79	28.50	5.18	5.18	3212	
		0.00	8.28	2.91	26.93	26.93	26.93p	11229	
20	43.00	0.00	12.08	4.24	39.29	39.29	39.29p	11410	
21	42.50	4.90	17.18	6.03	55.87	55.87	60.77p	11885	
22	42.00	9.81	22.27	7.82	72.44	72.44	82.25p	12360	
23	41.50	14.71	27.37	9.61	89.02	89.02	103.74p	12836	
24	41.13	18.39	31.19	10.96	101.46	98.45	116.84	13192	
25	40.75	22.07	35.02	12.30	113.90	92.62	114.69	13549	

Note: 91.95a Soil pressure at active limit
 103.74p Soil pressure at passive limit

Units: kN,m

Stage No.11 Change soil type 3 to soil type 4

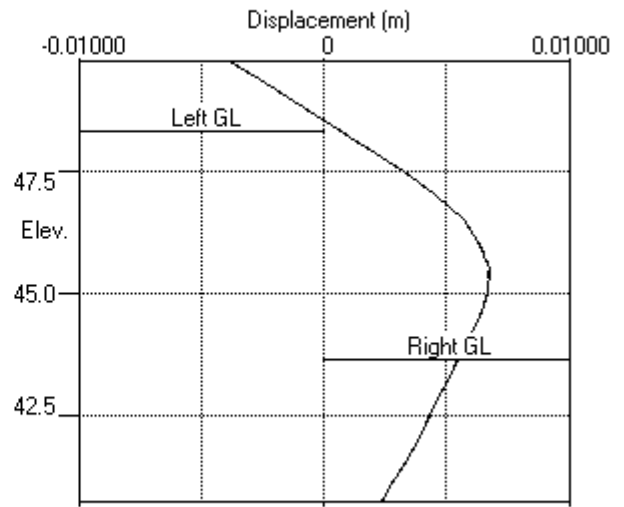
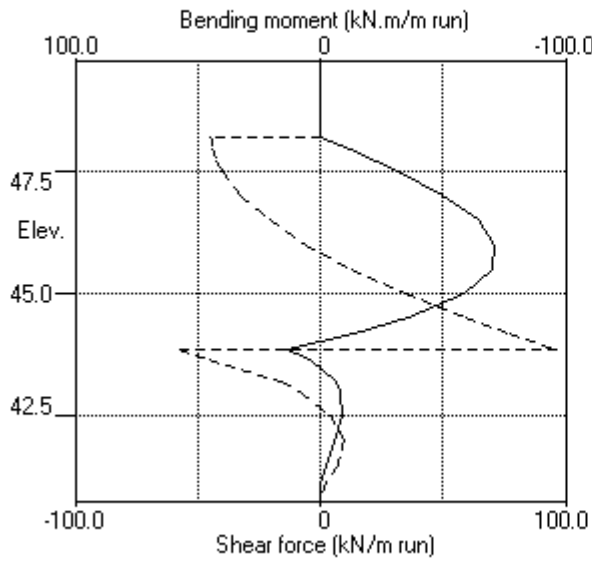

Stage No.11 Change soil type 3 to soil type 4

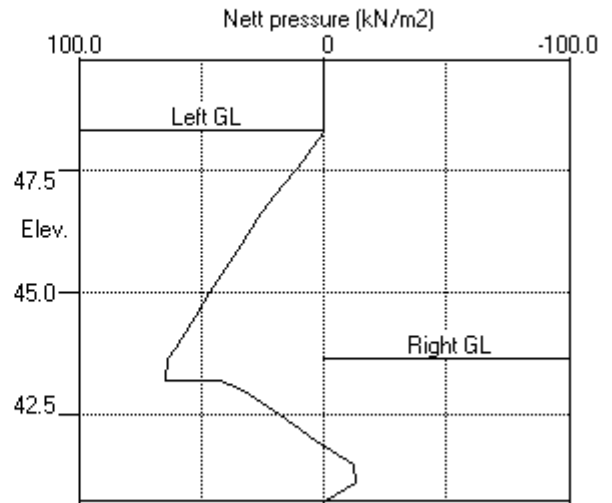
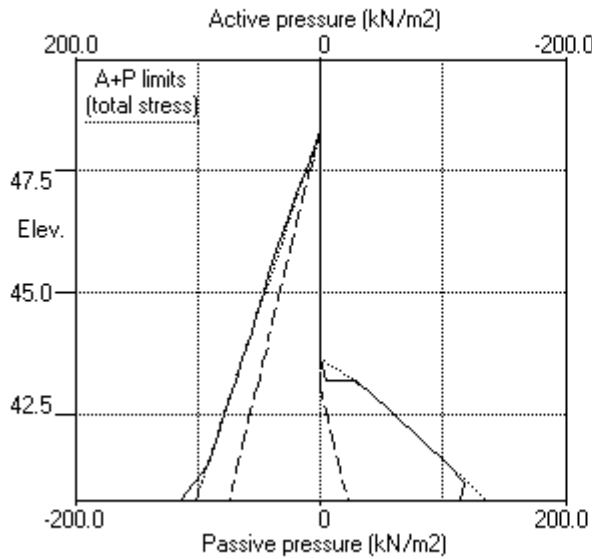

PILEDESIGNS LTD
 Program: WALLAP Version 6.06 Revision A51.B69.R54
 Licensed from GEOSOLVE
 Data filename/Run ID: Hampstead_Wall_4_450mm_rev_01_ULS1
 Hampstead - 24-26 Redington Gardens
 Wall 4, Secant-ULS1, 450 dia @ 650 - run 01

Sheet No.
 Job No. 21495
 Made by : DBS
 Date: 1-10-2018
 Checked :

Units: kN,m

Summary of results

BENDING MOMENT and DISPLACEMENT ANALYSIS of Fully Embedded Wall

Analysis options

Length of wall perpendicular to section = 50.00m
 Subgrade reaction model - Boussinesq Influence coefficients
 Soil deformations are elastic until the active or passive limit is reached
 Open Tension Crack analysis - No

Rigid boundaries: Left side 50.00 from wall
 Right side 50.00 from wall

Limit State: ULS DA1 Combination 1

Calculated Bending Moments and Strut Forces have been multiplied by a factor of 1.35 to obtain values for structural design.

Bending moment, shear force and displacement envelopes

Node no.	Y coord	Displacement		Bending moment				Shear force			
		max. m	min. m	Calculated		Factored		Calculated		Factored	
				max. kN.m/m	min. kN.m/m	max. kN.m/m	min. kN.m/m	max. kN/m	min. kN/m	max. kN/m	min. kN/m
1	49.75	0.001	-0.004	0	0	0	0	0	0	0	0
2	49.38	0.001	-0.003	0	-0	0	-0	0	-0	0	-1
3	49.00	0.001	-0.002	0	-0	0	-1	0	-2	0	-3
4	48.65	0.001	-0.002	0	-2	0	-2	0	-4	0	-5
5	48.30	0.001	-0.001	0	-3	0	-5	0	-7	0	-9
6	48.21	0.001	-0.001	0	-4	0	-5	0	-52	0	-70
7	47.96	0.002	-0.001	0	-13	0	-18	1	-51	1	-69
8	47.70	0.003	-0.001	1	-26	1	-35	3	-49	4	-66
9	47.50	0.003	-0.001	1	-35	2	-48	4	-47	6	-64
10	47.00	0.005	-0.001	4	-56	6	-76	4	-40	6	-54
11	46.50	0.006	-0.001	6	-74	8	-100	3	-29	4	-39
12	46.00	0.007	-0.001	7	-85	9	-114	4	-15	6	-20
13	45.50	0.007	-0.000	6	-88	8	-118	13	-3	18	-4
14	45.00	0.007	-0.000	4	-81	5	-110	35	-5	47	-7
15	44.50	0.006	-0.000	2	-67	2	-91	59	-4	80	-5
16	44.17	0.006	-0.000	1	-56	2	-75	77	-3	104	-4
17	43.85	0.006	-0.000	14	-42	19	-56	96	-58	130	-78
18	43.65	0.005	-0.000	4	-32	6	-43	52	-45	70	-61
19	43.19	0.005	-0.000	6	-6	8	-8	66	-16	89	-21
20	43.00	0.005	-0.000	15	-8	20	-11	48	-9	64	-12
21	42.50	0.004	-0.000	23	-9	31	-12	11	-1	15	-1
22	42.00	0.004	-0.000	19	-6	26	-8	9	-15	13	-20
23	41.50	0.003	-0.000	10	-2	13	-3	7	-18	10	-24
24	41.13	0.003	-0.000	3	-0	4	-0	3	-13	3	-18
25	40.75	0.002	-0.000	0	-0	0	-0	0	-0	0	-0

Summary of results (continued)

Calculated Bending Moments and Strut Forces have been multiplied by a factor of 1.35 to obtain values for structural design.

Maximum and minimum bending moment and shear force at each stage

Stage no.	Bending moment				Shear force					
	Calculated		Factored		Calculated		Factored			
min.	max. elev.	min. elev.	max. elev.	max. elev.	min. elev.	max. elev.	min. elev.	max. elev.		
	kN.m/m	kN.m/m	kN.m/m	kN/m	kN/m	kN/m	kN/m	kN/m		
1	43.00	-14	46.50	1	-19	8	45.00	-8	47.50	11
-11	42.50	-14	46.50	0	-19	7	45.00	-8	47.70	10
3	42.50	-14	46.50	0	-18	7	45.00	-8	47.96	10
-11	46.00	-1	43.00	9	-1	4	47.00	-5	45.00	6
5	No calculation at this stage									
6	43.65	-2	45.50	2	-2	4	45.00	-4	48.21	6
-6	42.50	-87	45.50	27	-117	64	43.19	-51	48.21	86
-69	42.50	-88	45.50	28	-118	66	43.19	-52	48.21	89
-70	No calculation at this stage									
10	42.50	-78	45.50	31	-105	52	43.19	-47	48.21	70
-63	43.85	-71	46.00	19	-96	96	43.85	-58	43.85	130
-78	No calculation at this stage									
13	41.13	-76	45.50	0	-102	91	43.85	-46	48.21	123
-62										

Maximum and minimum displacement at each stage

Stage no.	Displacement				Stage description
	maximum elev.	minimum elev.	maximum elev.	minimum elev.	
	m	m	m	m	
1	0.000	49.75	-0.002	49.75	Excav. to elev. 48.30 on LEFT side
2	0.000	49.75	-0.002	49.75	Apply surcharge no.1 at elev. 48.30
3	0.000	49.75	-0.002	49.75	Apply water pressure profile no.1
4	0.001	49.75	0.000	49.75	Excav. to elev. 47.70 on RIGHT side
5	No calculation at this stage				Install strut no.1 at elev. 48.21
6	0.001	49.75	0.000	49.75	Apply water pressure profile no.2
7	0.007	45.00	-0.003	49.75	Excav. to elev. 43.19 on RIGHT side
8	0.007	45.00	-0.003	49.75	Fill to elev. 43.65 on RIGHT side
9	No calculation at this stage				Install strut no.2 at elev. 43.85
10	0.007	45.50	-0.004	49.75	Change EI of wall to 43355kN.m2/m run
11	0.007	45.50	-0.004	49.75	Change soil type 3 to soil type 4
12	No calculation at this stage				Apply surcharge no.2 at elev. 43.65
13	0.007	45.50	-0.004	49.75	Apply water pressure profile no.3

Strut forces at each stage (horizontal components)

Stage no.	Strut no. 1			Strut no. 2		
	at elev. 48.21			at elev. 43.85		
	Calculated	Factored	Calculated	Factored	Factored	
	kN per m run	kN per strut	kN per strut	kN per m run	kN per strut	kN per strut
6	4	4	6	---	---	---
7	51	51	69	---	---	---
8	52	52	70	---	---	---
10	47	47	63	18	18	24
11	45	45	61	154	154	208
13	46	46	63	116	116	157

Units: kN,m

Bending moment, shear force, displacement envelopes

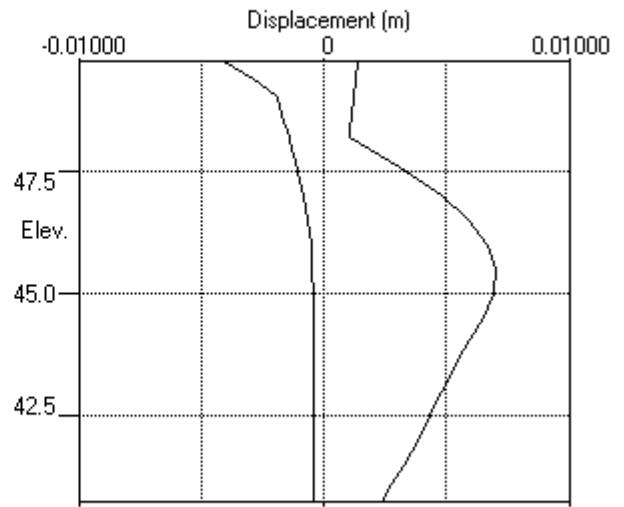
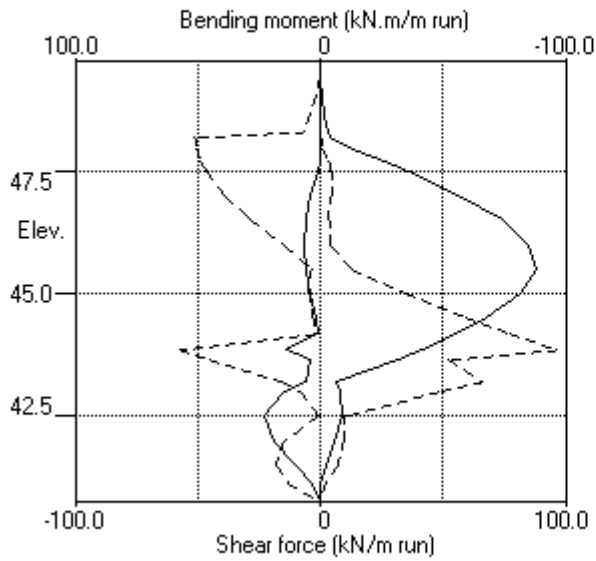



WALLAP

4-ULS2

PILEDESIGNS LTD
 Program: WALLAP Version 6.06 Revision A51.B69.R54
 Licensed from GEOSOLVE
 Data filename/Run ID: Hampstead_Wall_4_450mm_rev_01_ULS2
 Hampstead - 24-26 Redington Gardens
 Wall 4, Secant-ULS2, 450 dia @ 650 - run 01

Sheet No.
 Job No. 21495
 Made by : DBS
 Date: 1-10-2018
 Checked :

Units: kN,m

INPUT DATA

SOIL PROFILE

Stratum no.	Elevation of top of stratum	Soil types	
		Left side	Right side
1	49.75	1 Made Ground dr	1 Made Ground dr
2	47.50	2 Claygate Clay dr	2 Claygate Clay dr
3	45.00	3 London Clay und	3 London Clay und

SOIL PROPERTIES (Unfactored SLS soil strengths)

-- Soil type --	Bulk density	Young's Modulus	At rest coeff.	Consol state.	Active limit	Passive limit	Cohesion
No. Description (Datum elev.)	kN/m3	Eh,kN/m2 (dEh/dy)	Ko (dKo/dy)	NC/OC (Nu)	Ka (Kac)	Kp (Kpc)	kN/m2 (dc/dy)
1 Made Ground dr	18.00	10000	0.530	OC (0.250)	0.337 (0.000)	3.442 (0.000)	
2 Claygate Clay dr	19.00	30000	1.000	NC (0.200)	0.323 (1.330)	3.647 (5.195)	0.0d
3 London Cl.. (45.00)	20.00	40000 (4000)	1.000	OC (0.490)	1.000 (2.476)	1.000 (2.390)	50.00u (5.000)
4 London Cl.. (45.00)	20.00	30800 (3080)	1.000	OC (0.200)	0.351 (1.391)	3.253 (4.831)	0.0d

Additional soil parameters associated with Ka and Kp

No. Description	--- parameters for Ka ---			--- parameters for Kp ---		
	Soil friction angle	Wall adhesion coeff.	Back-fill angle	Soil friction angle	Wall adhesion coeff.	Back-fill angle
1 Made Ground dr	26.00	0.670	0.00	26.00	0.500	0.00
2 Claygate Clay dr	27.00	0.670	0.00	27.00	0.500	0.00
3 London Clay und	0.00	0.670	0.00	0.00	0.500	0.00
4 London Clay dr	25.00	0.670	0.00	25.00	0.500	0.00

GROUND WATER CONDITIONS

Density of water = 9.810 kN/m3

	Left side	Right side
Initial water table elevation	48.30	48.30

Automatic water pressure balancing at toe of wall : No

Water profile no.	Left side				Right side			
	Point no.	Elev. m	Piezo elev. m	Water press. kN/m2	Point no.	Elev. m	Piezo elev. m	Water press. kN/m2
1	1	48.30	48.30	0.0	1	47.50	47.50	0.0 MC+WC
2	1	48.30	48.30	0.0	1	43.00	43.00	0.0 MC+WC
3	1	48.30	48.30	0.0	1	43.65	43.65	0.0 MC+WC
					2	43.65	48.30	45.6

WALL PROPERTIES

Type of structure = Fully Embedded Wall
 Elevation of toe of wall = 40.75
 Maximum finite element length = 0.50 m
 Youngs modulus of wall E = 1.9600E+07 kN/m2
 Moment of inertia of wall I = 3.0968E-03 m4/m run
 E.I = 60696 kN.m2/m run
 Yield Moment of wall = Not defined

STRUTS and ANCHORS

Strut/ anchor no.	Elev.	Strut spacing m	X-section area of strut sq.m	Youngs modulus kN/m ²	Free length m	Inclin -ation (degs)	Pre- stress /strut kN	Tension allowed
1	48.21	1.00	0.400000	1.400E+07	5.00	0.00	0	No
2	43.85	1.00	0.300000	1.400E+07	5.00	0.00	0	No

SURCHARGE LOADS

Surch -arge no.	Elev.	Distance from wall	Length parallel to wall	Width perpend. to wall	Surcharge Near edge kN/m ²	Surcharge Far edge kN/m ²	Equiv. soil type	Partial factor/ Category
1	48.30	0.50(L)	10.00	10.00	10.00	=	N/A	1.30 Var
2	43.65	-0.00(R)	10.00	10.00	46.00	=	N/A	1.00 P/F

Note: L = Left side, R = Right side

Limit State Categories P/U = Permanent Unfavourable
P/F = Permanent Favourable
Var = Variable (unfavourable)

CONSTRUCTION STAGES

Construction stage no.	Stage description
1	Excavate to elevation 48.30 on LEFT side
2	Apply surcharge no.1 at elevation 48.30
3	Apply water pressure profile no.1 (Worst Cred.)
4	Excavate to elevation 47.70 on RIGHT side
5	Install strut or anchor no.1 at elevation 48.21
6	Apply water pressure profile no.2 (Worst Cred.)
7	Excavate to elevation 43.19 on RIGHT side
8	Fill to elevation 43.65 on RIGHT side with soil type 1
9	Install strut or anchor no.2 at elevation 43.85
10	Change EI of wall to 43355 kN.m ² /m run Yield moment not defined Allow wall to relax with new modulus value
11	Change properties of soil type 3 to soil type 4 Ko pressures will not be reset
12	Apply surcharge no.2 at elevation 43.65 No analysis at this stage
13	Apply water pressure profile no.3 (Worst Cred.)

FACTORS OF SAFETY and ANALYSIS OPTIONS

Limit State options: ULS DA1 Combination 2

Water pressures : Worst Credible

Partial factor on C' = 1.250

Partial factor on Phi' = 1.250

Partial factor on Cu = 1.400

Partial factor on Soil Modulus = 1.000

Partial factor on Permanent Unfavourable loads = 1.000

Partial factor on Permanent Favourable loads = 1.000

Partial factor on Variable Unfavourable loads = 1.300

Stability analysis:

Method of analysis - Strength Factor method

Overall factor on soil strength for calculating wall depth = 1.00

Parameters for undrained strata:

Minimum equivalent fluid density = 5.00 kN/m³

Maximum depth of water filled tension crack = 0.00 m

Bending moment and displacement calculation:

Method - Subgrade reaction model using Influence Coefficients

Open Tension Crack analysis? - No

Non-linear Modulus Parameter (L) = 9.000 m

Boundary conditions:

Length of wall (normal to plane of analysis) = 50.00 m

Width of excavation on Left side of wall = 50.00 m

Width of excavation on Right side of wall = 50.00 m

Distance to rigid boundary on Left side = 50.00 m

Distance to rigid boundary on Right side = 50.00 m

OUTPUT OPTIONS

Stage no.	Stage description	Displacement	Active, Passive pressures	Graph. output
1	Excav. to elev. 48.30 on LEFT side	Yes	Yes	Yes
2	Apply surcharge no.1 at elev. 48.30	No	No	No
3	Apply water pressure profile no.1	Yes	Yes	Yes
4	Excav. to elev. 47.70 on RIGHT side	Yes	Yes	Yes
5	Install strut no.1 at elev. 48.21	Yes	Yes	Yes
6	Apply water pressure profile no.2	Yes	Yes	Yes
7	Excav. to elev. 43.19 on RIGHT side	Yes	Yes	Yes
8	Fill to elev. 43.65 on RIGHT side	Yes	Yes	Yes
9	Install strut no.2 at elev. 43.85	Yes	Yes	Yes
10	Change EI of wall to 43355kN.m2/m run	No	No	No
11	Change soil type 3 to soil type 4	No	No	No
12	Apply surcharge no.2 at elev. 43.65	No	No	No
13	Apply water pressure profile no.3	No	No	No
*	Summary output	Yes	-	Yes

Program WALLAP - Copyright (C) 2017 by DL Borin, distributed by GEOSOLVE
 150 St. Alphonsus Road, London SW4 7BW, UK www.geosolve.co.uk

Units: kN,m

Stage No.13 Apply water pressure profile no.3 (Worst Cred.)

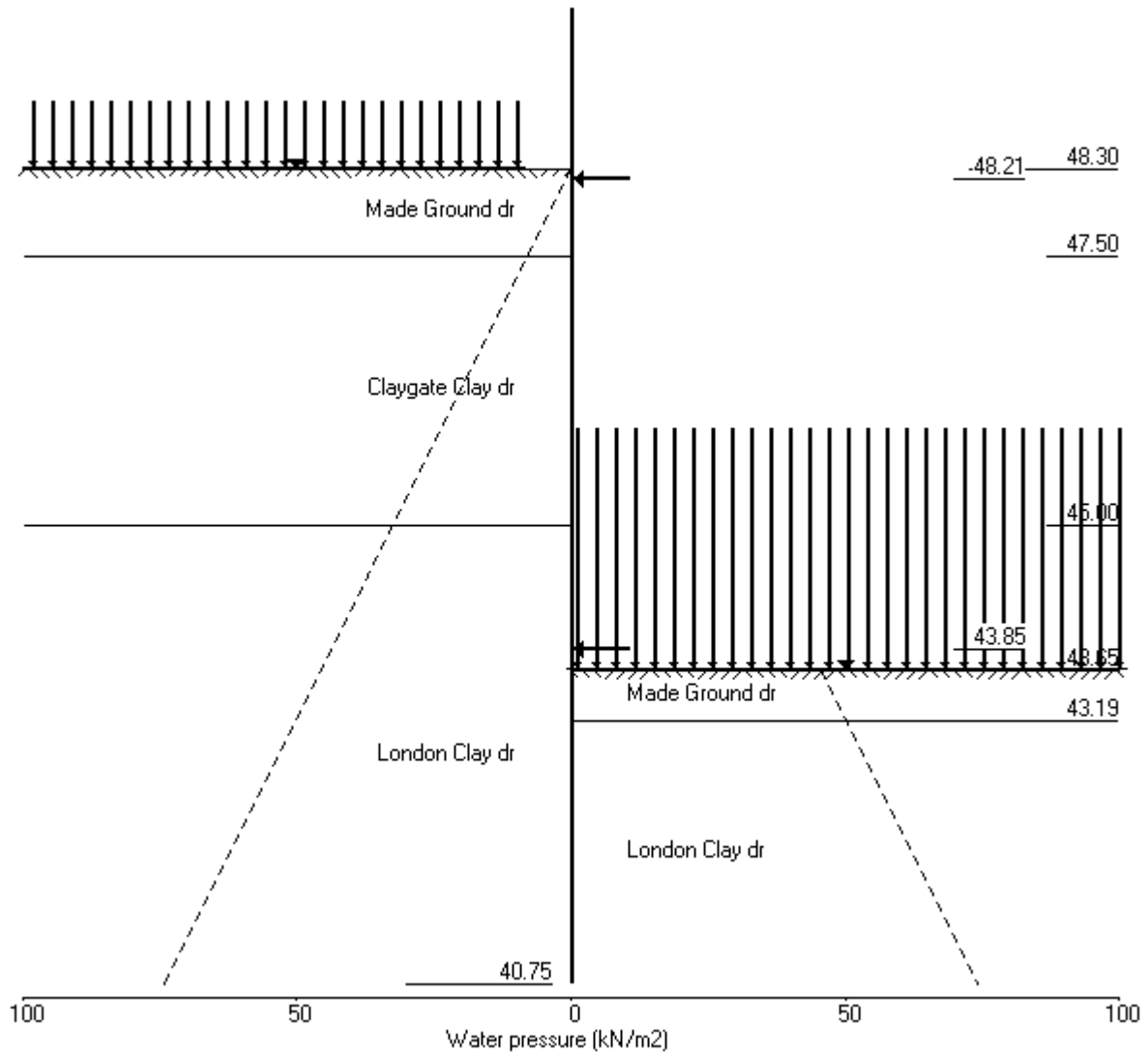

PILEDESIGNS LTD
 Program: WALLAP Version 6.06 Revision A51.B69.R54
 Licensed from GEOSOLVE
 Data filename/Run ID: Hampstead_Wall_4_450mm_rev_01_ULS2
 Hampstead - 24-26 Redington Gardens
 Wall 4, Secant-ULS2, 450 dia @ 650 - run 01

Sheet No.
 Job No. 21495
 Made by : DBS
 Date: 1-10-2018
 Checked :

Units: kN,m

Stage No. 1 Excavate to elevation 48.30 on LEFT side

STABILITY ANALYSIS of Fully Embedded Wall according to Strength Factor method
 Factor of safety on soil strength

			Overall		Toe elev. for			
			FoS for toe		FoS = 1.000			
			elev. = 40.75					
Stage No.	--- G.L. Act.	--- Pass.	Strut Elev.	Factor of Safety	Moment of equil. at elev.	Toe elev.	Wall Penetr-ation	Direction of failure
1	49.75	48.30	Cant.	2.711	41.78	45.46	2.84	R to L

BENDING MOMENT and DISPLACEMENT ANALYSIS of Fully Embedded Wall

Analysis options

Length of wall perpendicular to section = 50.00m

Subgrade reaction model - Boussinesq Influence coefficients

Soil deformations are elastic until the active or passive limit is reached

Open Tension Crack analysis - No

Rigid boundaries: Left side 50.00 from wall
 Right side 50.00 from wall

Limit State: ULS DA1 Combination 2

Node no.	Y coord	Nett pressure kN/m ²	Wall disp. m	Wall rotation rad.	Shear force kN/m	Bending moment kN.m/m	Strut forces kN/m	EI of wall kN.m ² /m
1	49.75	0.00	-0.004	-9.52E-04	0.0	-0.0		60696
2	49.38	-2.77	-0.003	-9.52E-04	-0.5	-0.1		60696
3	49.00	-5.54	-0.003	-9.50E-04	-2.1	-0.5		60696
4	48.65	-8.12	-0.003	-9.44E-04	-4.5	-1.6		60696
5	48.30	-10.71	-0.002	-9.29E-04	-7.8	-3.8		60696
6	48.21	-9.04	-0.002	-9.23E-04	-8.7	-4.5		60696
7	47.96	-4.34	-0.002	-8.99E-04	-10.4	-6.9		60696
8	47.70	0.37	-0.002	-8.64E-04	-10.9	-9.7		60696
9	47.50	2.68	-0.002	-8.28E-04	-10.6	-11.9		60696
		3.28	-0.002	-8.28E-04	-10.6	-11.9		
10	47.00	7.49	-0.001	-7.12E-04	-7.9	-16.4		60696
11	46.50	12.39	-0.001	-5.66E-04	-2.9	-19.1		60696
12	46.00	10.85	-0.001	-4.08E-04	2.9	-19.3		60696
13	45.50	7.02	-0.001	-2.60E-04	7.4	-16.5		60696
14	45.00	4.73	-0.000	-1.43E-04	10.3	-11.9		60696
		-3.53	-0.000	-1.43E-04	10.3	-11.9		
15	44.50	-4.79	-0.000	-6.47E-05	8.2	-7.2		60696
16	44.17	-4.89	-0.000	-3.25E-05	6.7	-4.8		60696
17	43.85	-4.63	-0.000	-1.19E-05	5.1	-2.9		60696
18	43.65	-4.34	-0.000	-3.98E-06	4.2	-2.0		60696
19	43.19	-3.46	-0.000	5.26E-06	2.4	-0.5		60696
20	43.00	-3.05	-0.000	6.14E-06	1.8	-0.1		60696
21	42.50	-1.97	-0.000	4.67E-06	0.5	0.4		60696
22	42.00	-0.96	-0.000	9.56E-07	-0.2	0.5		60696
23	41.50	-0.05	-0.000	-2.00E-06	-0.4	0.3		60696
24	41.13	0.59	-0.000	-3.04E-06	-0.3	0.1		60696
25	40.75	1.21	-0.000	-3.31E-06	-0.0	-0.0		---

(continued)

Stage No.1 Excavate to elevation 48.30 on LEFT side

Node no.	Y coord	LEFT side					Total earth pressure kN/m2	Coeff. of subgrade reaction kN/m3
		Water press. kN/m2	Vertic -al kN/m2	Effective Active limit kN/m2	Effective Passive limit kN/m2	Earth pressure kN/m2		
1	49.75	0.00	0.00	0.00	0.00	0.00	0.00	0.0
2	49.38	0.00	0.00	0.00	0.00	0.00	0.00	0.0
3	49.00	0.00	0.00	0.00	0.00	0.00	0.00	0.0
4	48.65	0.00	0.00	0.00	0.00	0.00	0.00	0.0
5	48.30	0.00	0.00	0.00	0.00	0.00	0.00	0.0
		0.00	0.00	0.00	0.00	0.00	0.00	4380
6	48.21	0.88	0.74	0.30	1.96	1.96	2.85p	4380
7	47.96	3.38	2.83	1.16	7.53	7.53	10.91p	4380
8	47.70	5.89	4.91	2.02	13.09	13.09	18.98p	4380
9	47.50	7.85	6.55	2.69	17.45	16.08	23.92	4380
		7.85	6.55	2.59	18.27	18.27	26.11p	12659
10	47.00	12.75	11.15	4.41	31.08	31.08	43.83p	12659
11	46.50	17.66	15.74	6.23	43.89	43.89	61.55p	12659
12	46.00	22.56	20.34	8.05	56.70	49.47	72.03	12659
13	45.50	27.47	24.93	9.86	69.51	51.96	79.43	12659
14	45.00	32.37	29.53	11.68	82.33	55.29	87.67	12659
		Total>	61.90	16.50m	147.27	74.70	74.70	24080
15	44.50	Total>	71.90	19.00m	161.54	84.02	84.02	25284
16	44.17	Total>	78.41	20.63m	170.81	90.46	90.46	26067
17	43.85	Total>	84.91	22.25m	180.09	97.10	97.10	26849
18	43.65	Total>	88.91	23.25m	185.80	101.26	101.26	27331
19	43.19	Total>	98.11	25.55m	198.93	110.95	110.95	28439
20	43.00	Total>	101.91	26.50m	204.35	114.97	114.97	28896
21	42.50	Total>	111.92	29.00m	218.62	125.56	125.56	30100
22	42.00	Total>	121.92	31.50m	232.90	136.11	136.11	31304
23	41.50	Total>	131.93	34.00m	247.17	146.62	146.62	32508
24	41.13	Total>	139.43	35.87m	257.88	154.47	154.47	33411
25	40.75	Total>	146.94	37.75m	268.59	162.31	162.31	34314

Node no.	Y coord	RIGHT side					Total earth pressure kN/m2	Coeff. of subgrade reaction kN/m3
		Water press. kN/m2	Vertic -al kN/m2	Effective Active limit kN/m2	Effective Passive limit kN/m2	Earth pressure kN/m2		
1	49.75	0.00	0.00	0.00	0.00	0.00	0.00	3588
2	49.38	0.00	6.75	2.77	17.98	2.77	2.77a	3588
3	49.00	0.00	13.50	5.54	35.96	5.54	5.54a	3588
4	48.65	0.00	19.80	8.12	52.74	8.12	8.12a	3588
5	48.30	0.00	26.10	10.71	69.52	10.71	10.71a	3588
6	48.21	0.88	26.84	11.01	71.49	11.01	11.89a	3588
7	47.96	3.38	28.93	11.86	77.05	11.86	15.25a	3588
8	47.70	5.89	31.01	12.72	82.61	12.72	18.61a	3588
9	47.50	7.85	32.65	13.39	86.98	13.39	21.24a	3588
		7.85	32.65	12.92	91.03	14.99	22.84	10354
10	47.00	12.75	37.25	14.74	103.84	23.59	36.34	10354
11	46.50	17.66	41.84	16.55	116.65	31.50	49.16	10354
12	46.00	22.56	46.44	18.37	129.46	38.62	61.18	10354
13	45.50	27.47	51.03	20.19	142.27	44.94	72.41	10354
14	45.00	32.37	55.63	22.01	155.08	50.56	82.94	10354
		Total>	88.00	23.75m	173.37	78.23	78.23	19971
15	44.50	Total>	98.00	26.25m	187.64	88.80	88.80	20970
16	44.17	Total>	104.50	27.88m	196.91	95.35	95.35	21619
17	43.85	Total>	111.00	29.50m	206.19	101.73	101.73	22268
18	43.65	Total>	115.00	30.50m	211.89	105.60	105.60	22667

(continued)

Stage No.1 Excavate to elevation 48.30 on LEFT side

Node no.	Y coord	----- RIGHT side -----					Total earth pressure kN/m2	Coeff. of subgrade reaction kN/m3
		Water press. kN/m2	Vertic -al kN/m2	Effective Active limit kN/m2	Effective Passive limit kN/m2	Earth pressure kN/m2		
19	43.19	Total>	124.20	32.80m	225.02	114.40	114.40	23586
20	43.00	Total>	128.00	33.75m	230.44	118.02	118.02	23965
21	42.50	Total>	138.00	36.25m	244.71	127.53	127.53	24964
22	42.00	Total>	148.00	38.75m	258.98	137.08	137.08	25963
23	41.50	Total>	158.00	41.25m	273.25	146.67	146.67	26961
24	41.13	Total>	165.50	43.13m	283.95	153.88	153.88	27710
25	40.75	Total>	173.00	46.95	294.65	161.10	161.10	28459

Note: 21.24a Soil pressure at active limit
 61.55p Soil pressure at passive limit

Units: kN,m

Stage No.1 Excav. to elev. 48.30 on LEFT side

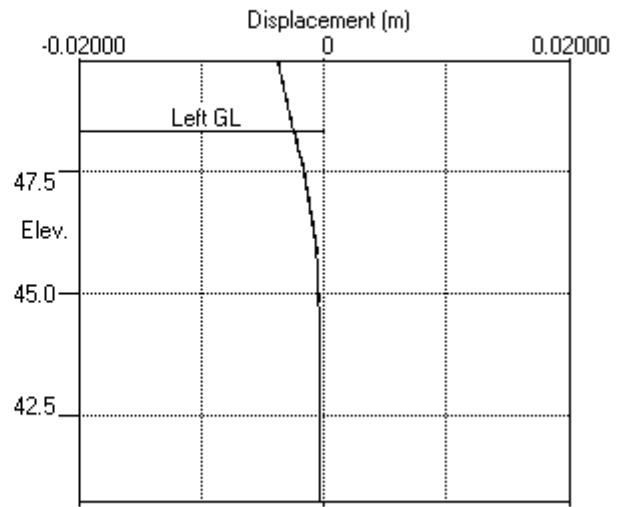
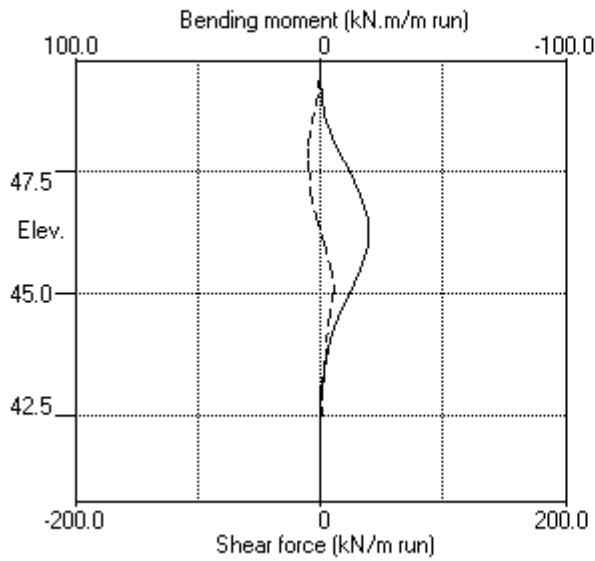

Stage No.1 Excav. to elev. 48.30 on LEFT side

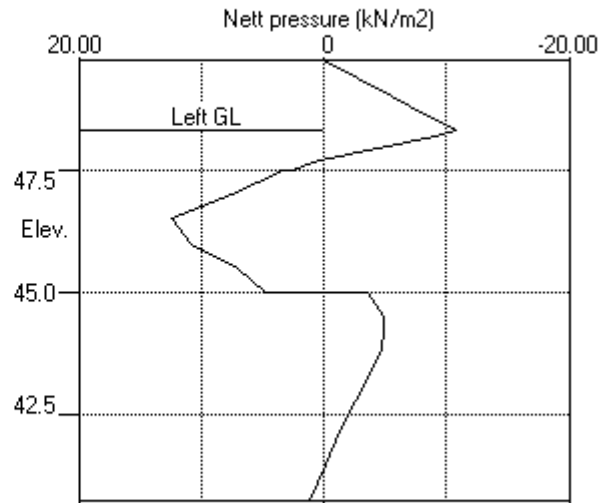
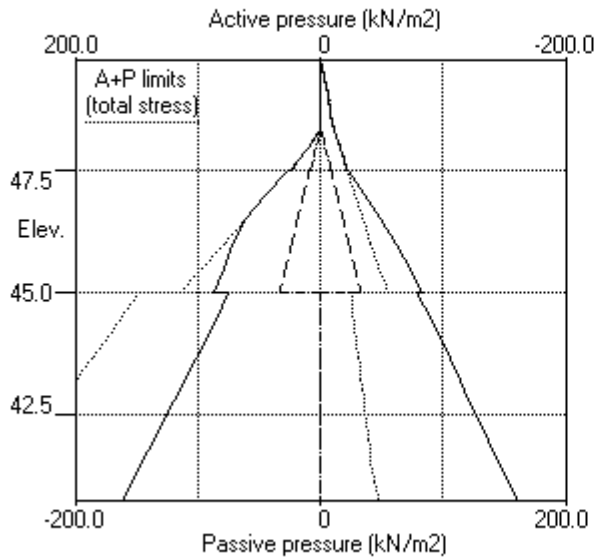

PILEDESIGNS LTD
 Program: WALLAP Version 6.06 Revision A51.B69.R54
 Licensed from GEOSOLVE
 Data filename/Run ID: Hampstead_Wall_4_450mm_rev_01_ULS2
 Hampstead - 24-26 Redington Gardens
 Wall 4, Secant-ULS2, 450 dia @ 650 - run 01

Sheet No.
 Job No. 21495
 Made by : DBS
 Date: 1-10-2018
 Checked :

Units: kN,m

Stage No. 4 Excavate to elevation 47.70 on RIGHT side

STABILITY ANALYSIS of Fully Embedded Wall according to Strength Factor method
 Factor of safety on soil strength

			Overall		Toe elev. for			
			FoS for toe		FoS = 1.000			
			elev. = 40.75					
Stage No.	--- G.L. Act.	--- Pass.	Strut Elev.	Factor of Safety	Moment at elev.	Toe elev.	Wall Penetr-ation	Direction of failure
4	48.30	47.70	Cant.	4.176	41.64	46.07	1.63	L to R

BENDING MOMENT and DISPLACEMENT ANALYSIS of Fully Embedded Wall

Analysis options

Length of wall perpendicular to section = 50.00m

Subgrade reaction model - Boussinesq Influence coefficients

Soil deformations are elastic until the active or passive limit is reached

Open Tension Crack analysis - No

Rigid boundaries: Left side 50.00 from wall

Right side 50.00 from wall

Limit State: ULS DA1 Combination 2

Node no.	Y coord	Nett pressure kN/m ²	Wall disp. m	Wall rotation rad.	Shear force kN/m	Bending moment kN.m/m	Strut forces kN/m	EI of wall kN.m ² /m
1	49.75	0.00	0.001	2.38E-04	0.0	0.0		60696
2	49.38	0.00	0.001	2.38E-04	0.0	0.0		60696
3	49.00	0.00	0.001	2.38E-04	0.0	0.0		60696
4	48.65	0.00	0.001	2.38E-04	0.0	0.0		60696
5	48.30	0.00	0.001	2.38E-04	0.0	0.0		60696
6	48.21	1.20	0.001	2.38E-04	0.1	0.0		60696
7	47.96	5.01	0.001	2.38E-04	0.8	0.1		60696
8	47.70	9.20	0.001	2.37E-04	2.7	0.5		60696
9	47.50	5.27	0.001	2.34E-04	4.1	1.2		60696
		2.24	0.001	2.34E-04	4.1	1.2		
10	47.00	-6.36	0.001	2.11E-04	3.1	4.3		60696
11	46.50	-0.64	0.001	1.71E-04	1.3	5.2		60696
12	46.00	-3.53	0.001	1.29E-04	0.3	5.2		60696
13	45.50	-5.57	0.001	8.56E-05	-2.0	5.3		60696
14	45.00	-4.12	0.000	4.87E-05	-4.4	3.6		60696
		1.88	0.000	4.87E-05	-4.4	3.6		
15	44.50	2.51	0.000	2.70E-05	-3.3	1.7		60696
16	44.17	2.50	0.000	2.06E-05	-2.5	0.7		60696
17	43.85	2.29	0.000	1.87E-05	-1.7	0.0		60696
18	43.65	2.09	0.000	1.91E-05	-1.3	-0.3		60696
19	43.19	1.53	0.000	2.26E-05	-0.5	-0.7		60696
20	43.00	1.28	0.000	2.48E-05	-0.2	-0.7		60696
21	42.50	0.66	0.000	3.04E-05	0.3	-0.7		60696
22	42.00	0.12	0.000	3.50E-05	0.5	-0.4		60696
23	41.50	-0.32	0.000	3.75E-05	0.4	-0.2		60696
24	41.13	-0.60	0.000	3.83E-05	0.3	-0.1		60696
25	40.75	-0.84	0.000	3.85E-05	0.0	0.0		---

(continued)

Stage No.4 Excavate to elevation 47.70 on RIGHT side

Node no.	Y coord	LEFT side					Total earth pressure kN/m2	Coeff. of subgrade reaction kN/m3
		Water press. kN/m2	Vertic -al kN/m2	Effective Active limit kN/m2	Effective Passive limit kN/m2	Earth pressure kN/m2		
1	49.75	0.00	0.00	0.00	0.00	0.00	0.00	0.0
2	49.38	0.00	0.00	0.00	0.00	0.00	0.00	0.0
3	49.00	0.00	0.00	0.00	0.00	0.00	0.00	0.0
4	48.65	0.00	0.00	0.00	0.00	0.00	0.00	0.0
5	48.30	0.00	0.00	0.00	0.00	0.00	0.00	0.0
		0.00	0.00	0.00	0.00	0.00	0.00	4306
6	48.21	0.88	0.77	0.32	2.05	0.32	1.20a	4306
7	47.96	3.38	3.95	1.62	10.53	1.62	5.01a	4306
8	47.70	5.89	8.09	3.32	21.54	3.32	9.20a	4306
9	47.50	7.85	11.19	4.59	29.80	7.01	14.86	4306
		7.85	11.19	4.43	31.19	4.43	12.27a	12446
10	47.00	12.75	18.25	7.22	50.88	8.64	21.39	12446
11	46.50	17.66	24.15	9.56	67.34	27.17	44.83	12446
12	46.00	22.56	29.44	11.65	82.08	37.09	59.66	12446
13	45.50	27.47	34.37	13.60	95.81	42.58	70.05	12446
14	45.00	32.37	39.06	15.45	108.90	47.74	80.11	12446
		Total>	71.44	16.50m	156.80	64.63	64.63	23700
15	44.50	Total>	81.38	19.00m	171.02	74.82	74.82	24885
16	44.17	Total>	87.79	20.63m	180.20	81.27	81.27	25656
17	43.85	Total>	94.16	22.25m	189.35	87.62	87.62	26426
18	43.65	Total>	98.07	23.25m	194.96	91.49	91.49	26900
19	43.19	Total>	107.03	25.55m	207.85	100.35	100.35	27990
20	43.00	Total>	110.72	26.50m	213.16	104.01	104.01	28440
21	42.50	Total>	120.41	29.00m	227.12	113.62	113.62	29625
22	42.00	Total>	130.09	31.50m	241.07	123.26	123.26	30810
23	41.50	Total>	139.76	34.00m	255.01	132.95	132.95	31995
24	41.13	Total>	147.02	35.87m	265.46	140.24	140.24	32884
25	40.75	Total>	154.27	37.75m	275.92	147.55	147.55	33773

Node no.	Y coord	RIGHT side					Total earth pressure kN/m2	Coeff. of subgrade reaction kN/m3
		Water press. kN/m2	Vertic -al kN/m2	Effective Active limit kN/m2	Effective Passive limit kN/m2	Earth pressure kN/m2		
1	49.75	0.00	0.00	0.00	0.00	0.00	0.00	0.0
2	49.38	0.00	0.00	0.00	0.00	0.00	0.00	0.0
3	49.00	0.00	0.00	0.00	0.00	0.00	0.00	0.0
4	48.65	0.00	0.00	0.00	0.00	0.00	0.00	0.0
5	48.30	0.00	0.00	0.00	0.00	0.00	0.00	0.0
6	48.21	0.00	0.00	0.00	0.00	0.00	0.00	0.0
7	47.96	0.00	0.00	0.00	0.00	0.00	0.00	0.0
8	47.70	0.00	0.00	0.00	0.00	0.00	0.00	0.0
		0.00	0.00	0.00	0.00	0.00	0.00	4624
9	47.50	0.00	3.60	1.48	9.59	9.59	9.59p	4624
		0.00	3.60	1.42	10.04	10.04	10.04p	13368
10	47.00	4.90	8.20	3.24	22.85	22.85	27.75p	13368
11	46.50	9.81	12.79	5.06	35.66	35.66	45.47p	13368
12	46.00	14.71	17.39	6.88	48.47	48.47	63.18p	13368
13	45.50	19.62	21.98	8.70	61.28	56.00	75.62	13368
14	45.00	24.52	26.58	10.52	74.10	59.71	84.23	13368
		Total>	51.10	13.50m	136.46	62.75	62.75	25348
15	44.50	Total>	61.10	16.00m	150.73	72.32	72.32	26615
16	44.17	Total>	67.61	17.63m	160.01	78.76	78.76	27439
17	43.85	Total>	74.11	19.25m	169.29	85.32	85.32	28263

(continued)

Stage No.4 Excavate to elevation 47.70 on RIGHT side

Node no.	Y coord	----- RIGHT side -----					Total earth pressure	Coeff. of subgrade reaction
		Water press. kN/m2	Vertic -al kN/m2	Effective Active limit kN/m2	Effective Passive limit kN/m2	Earth pressure kN/m2		
18	43.65	Total>	78.11	20.25m	175.00	89.40	89.40	28770
19	43.19	Total>	87.31	22.55m	188.13	98.82	98.82	29936
20	43.00	Total>	91.11	23.50m	193.55	102.72	102.72	30417
21	42.50	Total>	101.12	26.00m	207.82	112.96	112.96	31685
22	42.00	Total>	111.12	28.50m	222.10	123.15	123.15	32952
23	41.50	Total>	121.13	31.00m	236.37	133.27	133.27	34219
24	41.13	Total>	128.63	32.88m	247.08	140.84	140.84	35170
25	40.75	Total>	136.14	34.75m	257.79	148.38	148.38	36120

Note: 12.27a Soil pressure at active limit
 63.18p Soil pressure at passive limit

Units: kN,m

Stage No.4 Excav. to elev. 47.70 on RIGHT side

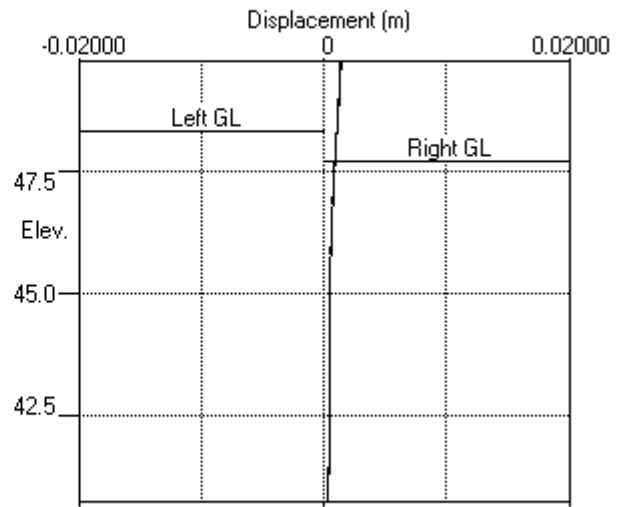
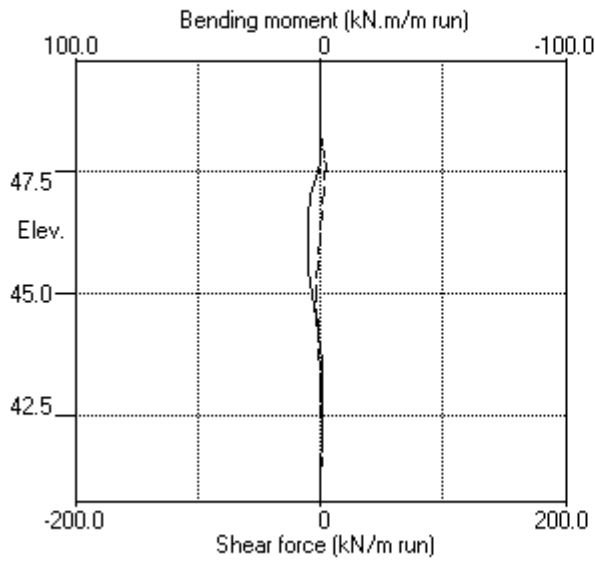

Stage No.4 Excav. to elev. 47.70 on RIGHT side

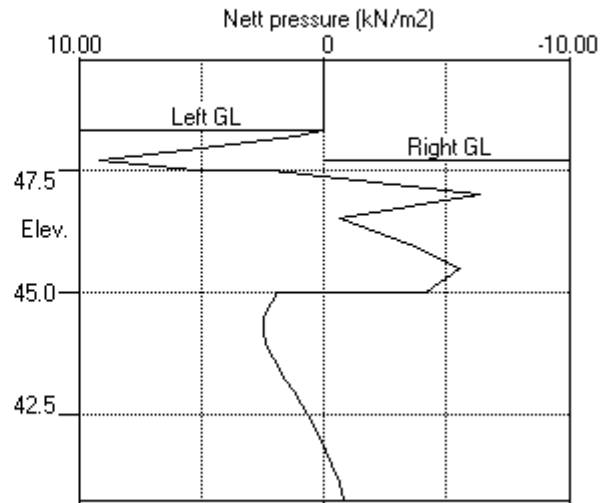
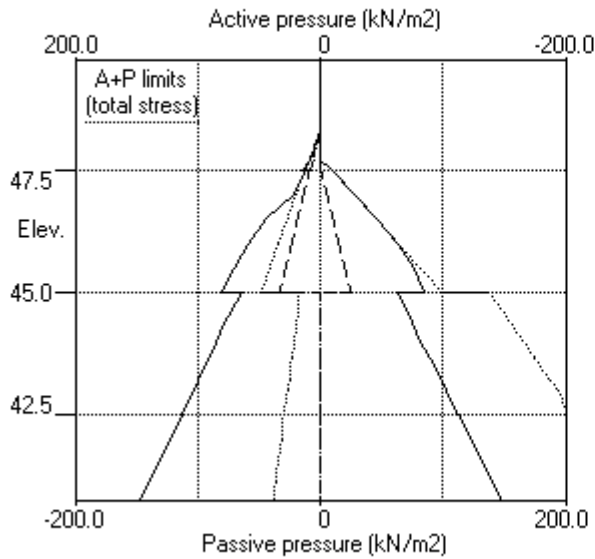

PILEDESIGNS LTD
 Program: WALLAP Version 6.06 Revision A51.B69.R54
 Licensed from GEOSOLVE
 Data filename/Run ID: Hampstead_Wall_4_450mm_rev_01_ULS2
 Hampstead - 24-26 Redington Gardens
 Wall 4, Secant-ULS2, 450 dia @ 650 - run 01

Sheet No.
 Job No. 21495
 Made by : DBS
 Date: 1-10-2018
 Checked :

Units: kN,m

Stage No. 7 Excavate to elevation 43.19 on RIGHT side

STABILITY ANALYSIS of Fully Embedded Wall according to Strength Factor method
 Factor of safety on soil strength

			Overall						
			FoS for toe	Toe elev. for					
			elev. = 40.75	FoS = 1.000					

Stage No.	--- G.L. Act.	--- Pass.	Strut Elev.	Factor of Safety	Moment of equil. at elev.	Toe elev.	Wall Penetr-ation	Direction of failure	
7	48.30	43.19	48.21	1.686	n/a	42.47	0.72	L to R	

BENDING MOMENT and DISPLACEMENT ANALYSIS of Fully Embedded Wall

Analysis options

Length of wall perpendicular to section = 50.00m

Subgrade reaction model - Boussinesq Influence coefficients

Soil deformations are elastic until the active or passive limit is reached

Open Tension Crack analysis - No

Rigid boundaries: Left side 50.00 from wall

Right side 50.00 from wall

Limit State: ULS DA1 Combination 2

Node no.	Y coord	Nett pressure kN/m2	Wall disp. m	Wall rotation rad.	Shear force kN/m	Bending moment kN.m/m	Strut forces kN/m	EI of wall kN.m2/m
1	49.75	0.00	-0.004	-3.26E-03	0.0	0.0		60696
2	49.38	0.00	-0.003	-3.26E-03	0.0	0.0		60696
3	49.00	0.00	-0.002	-3.26E-03	0.0	0.0		60696
4	48.65	0.00	-0.000	-3.26E-03	0.0	0.0		60696
5	48.30	0.00	0.001	-3.26E-03	0.0	0.0		60696
6	48.21	1.20	0.001	-3.26E-03	0.1	0.0	56.4	60696
		1.20	0.001	-3.26E-03	-56.3	0.0		
7	47.96	5.01	0.002	-3.23E-03	-55.6	-14.3		60696
8	47.70	9.20	0.003	-3.15E-03	-53.7	-28.2		60696
9	47.50	12.44	0.003	-3.04E-03	-51.6	-38.8		60696
		12.27	0.003	-3.04E-03	-51.6	-38.8		
10	47.00	19.97	0.005	-2.62E-03	-43.5	-61.5		60696
11	46.50	27.21	0.006	-2.04E-03	-31.7	-80.4		60696
12	46.00	34.21	0.007	-1.32E-03	-16.4	-93.1		60696
13	45.50	41.06	0.007	-5.48E-04	2.5	-96.2		60696
14	45.00	47.83	0.007	2.16E-04	24.7	-89.6		60696
		16.50	0.007	2.16E-04	24.7	-89.6		
15	44.50	19.00	0.007	8.95E-04	33.6	-75.2		60696
16	44.17	20.63	0.007	1.26E-03	40.0	-63.3		60696
17	43.85	22.25	0.006	1.56E-03	47.0	-49.2		60696
18	43.65	23.25	0.006	1.71E-03	51.5	-39.3		60696
19	43.19	28.03	0.005	1.90E-03	63.3	-10.6		60696
		-72.77	0.005	1.90E-03	63.3	-10.6		
20	43.00	-70.00	0.005	1.91E-03	49.7	0.2		60696
21	42.50	-62.02	0.004	1.85E-03	16.7	16.1		60696
22	42.00	-39.44	0.003	1.70E-03	-8.6	20.5		60696
23	41.50	-2.74	0.002	1.57E-03	-19.2	11.2		60696
24	41.13	25.10	0.001	1.52E-03	-15.0	3.9		60696
25	40.75	54.80	0.001	1.51E-03	0.0	0.0		---
At elev. 48.21 Strut force =			56.4 kN/strut =		56.4 kN/m run			

(continued)

Stage No.7 Excavate to elevation 43.19 on RIGHT side

Node no.	Y coord	LEFT side					Total earth pressure kN/m2	Coeff. of subgrade reaction kN/m3
		Water press. kN/m2	Vertic -al kN/m2	Effective Active limit kN/m2	Effective Passive limit kN/m2	Earth pressure kN/m2		
1	49.75	0.00	0.00	0.00	0.00	0.00	0.00	0.0
2	49.38	0.00	0.00	0.00	0.00	0.00	0.00	0.0
3	49.00	0.00	0.00	0.00	0.00	0.00	0.00	0.0
4	48.65	0.00	0.00	0.00	0.00	0.00	0.00	0.0
5	48.30	0.00	0.00	0.00	0.00	0.00	0.00	0.0
		0.00	0.00	0.00	0.00	0.00	0.00	71613
6	48.21	0.88	0.77	0.32	2.05	0.32	1.20a	2264
7	47.96	3.38	3.95	1.62	10.53	1.62	5.01a	2264
8	47.70	5.89	8.09	3.32	21.54	3.32	9.20a	2264
9	47.50	7.85	11.19	4.59	29.80	4.59	12.44a	2264
		7.85	11.19	4.43	31.19	4.43	12.27a	6502
10	47.00	12.75	18.25	7.22	50.88	7.22	19.97a	6502
11	46.50	17.66	24.15	9.56	67.34	9.56	27.21a	6502
12	46.00	22.56	29.44	11.65	82.08	11.65	34.21a	6502
13	45.50	27.47	34.37	13.60	95.81	13.60	41.06a	6502
14	45.00	32.37	39.06	15.45	108.90	15.45	47.83a	6502
		Total>	71.44	16.50m	156.80	16.50	16.50a	13187
15	44.50	Total>	81.38	19.00m	171.02	19.00	19.00a	13847
16	44.17	Total>	87.79	20.63m	180.20	20.63	20.63a	14275
17	43.85	Total>	94.16	22.25m	189.35	22.25	22.25a	14704
18	43.65	Total>	98.07	23.25m	194.96	23.25	23.25a	14967
19	43.19	Total>	107.03	25.55m	207.85	28.03	28.03	15574
20	43.00	Total>	110.72	26.50m	213.16	36.23	36.23	15825
21	42.50	Total>	120.41	29.00m	227.12	58.47	58.47	16484
22	42.00	Total>	130.09	31.50m	241.07	80.93	80.93	17143
23	41.50	Total>	139.76	34.00m	255.01	103.20	103.20	17803
24	41.13	Total>	147.02	35.87m	265.46	120.02	120.02	18297
25	40.75	Total>	154.27	37.75m	275.92	137.59	137.59	18792

Node no.	Y coord	RIGHT side					Total earth pressure kN/m2	Coeff. of subgrade reaction kN/m3
		Water press. kN/m2	Vertic -al kN/m2	Effective Active limit kN/m2	Effective Passive limit kN/m2	Earth pressure kN/m2		
1	49.75	0.00	0.00	0.00	0.00	0.00	0.00	0.0
2	49.38	0.00	0.00	0.00	0.00	0.00	0.00	0.0
3	49.00	0.00	0.00	0.00	0.00	0.00	0.00	0.0
4	48.65	0.00	0.00	0.00	0.00	0.00	0.00	0.0
5	48.30	0.00	0.00	0.00	0.00	0.00	0.00	0.0
6	48.21	0.00	0.00	0.00	0.00	0.00	0.00	0.0
7	47.96	0.00	0.00	0.00	0.00	0.00	0.00	0.0
8	47.70	0.00	0.00	0.00	0.00	0.00	0.00	0.0
9	47.50	0.00	0.00	0.00	0.00	0.00	0.00	0.0
10	47.00	0.00	0.00	0.00	0.00	0.00	0.00	0.0
11	46.50	0.00	0.00	0.00	0.00	0.00	0.00	0.0
12	46.00	0.00	0.00	0.00	0.00	0.00	0.00	0.0
13	45.50	0.00	0.00	0.00	0.00	0.00	0.00	0.0
14	45.00	0.00	0.00	0.00	0.00	0.00	0.00	0.0
15	44.50	0.00	0.00	0.00	0.00	0.00	0.00	0.0
16	44.17	0.00	0.00	0.00	0.00	0.00	0.00	0.0
17	43.85	0.00	0.00	0.00	0.00	0.00	0.00	0.0
18	43.65	0.00	0.00	0.00	0.00	0.00	0.00	0.0
19	43.19	0.00	0.00	0.00	0.00	0.00	0.00	0.0
		Total>	0.00	0.00	100.80	100.80	100.80p	30792

(continued)

Stage No.7 Excavate to elevation 43.19 on RIGHT side

Node no.	Y coord	----- RIGHT side -----					Total earth pressure kN/m2	Coeff. of subgrade reaction kN/m3
		Water press. kN/m2	Vertic -al kN/m2	Effective Active limit kN/m2	Effective Passive limit kN/m2	Earth pressure kN/m2		
20	43.00	Total>	3.80	0.95m	106.23	106.23	106.23p	31287
21	42.50	Total>	13.80	3.45m	120.50	120.50	120.50p	32591
22	42.00	Total>	23.80	5.95m	134.77	120.37	120.37	33895
23	41.50	Total>	33.80	8.45m	149.04	105.95	105.95	35198
24	41.13	Total>	41.30	10.33m	159.74	94.92	94.92	36176
25	40.75	Total>	48.81	12.20m	170.44	82.79	82.79	37154

Note: 23.25a Soil pressure at active limit
 120.50p Soil pressure at passive limit

Units: kN,m

Stage No.7 Excav. to elev. 43.19 on RIGHT side

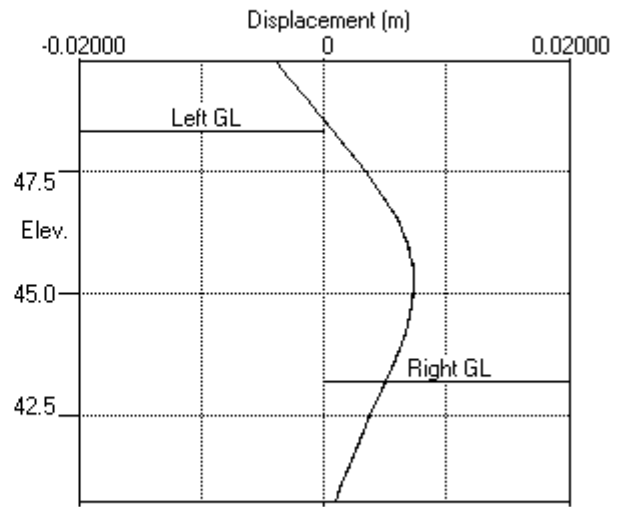
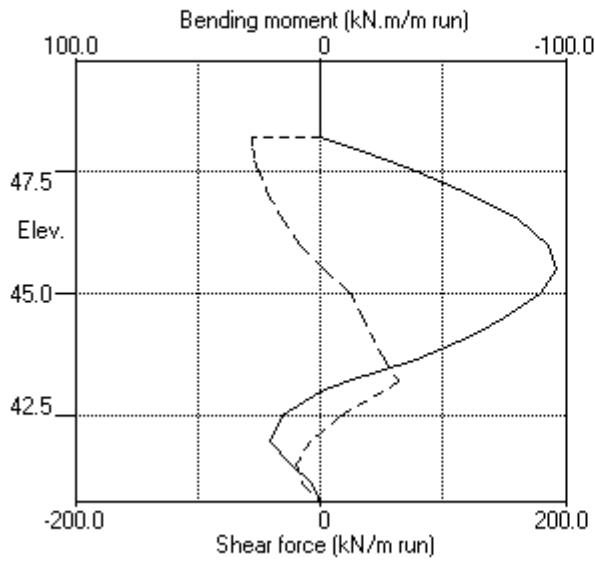

Stage No.7 Excav. to elev. 43.19 on RIGHT side

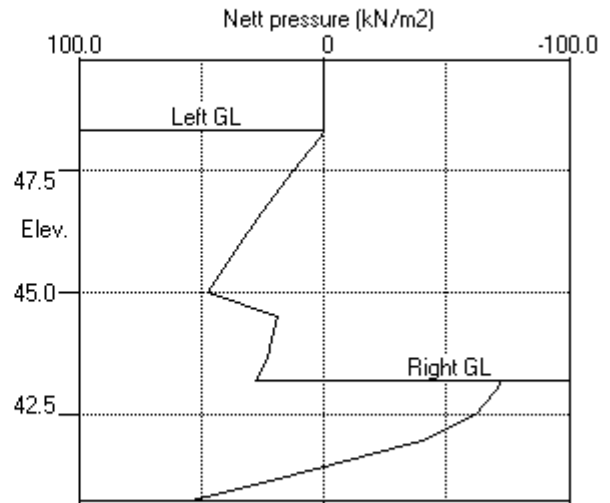
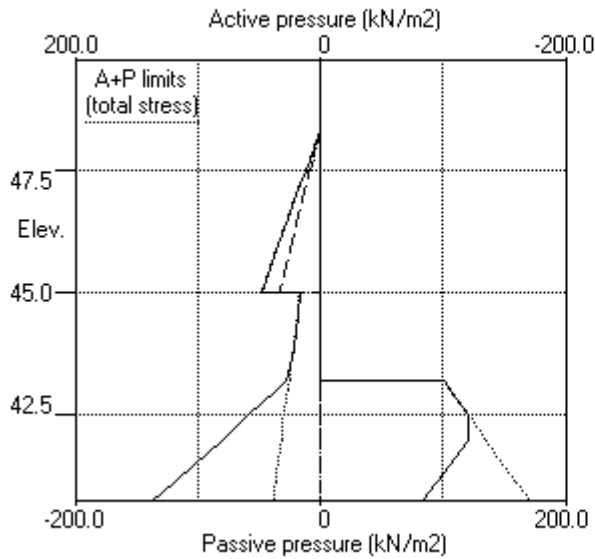

PILEDESIGNS LTD
 Program: WALLAP Version 6.06 Revision A51.B69.R54
 Licensed from GEOSOLVE
 Data filename/Run ID: Hampstead_Wall_4_450mm_rev_01_ULS2
 Hampstead - 24-26 Redington Gardens
 Wall 4, Secant-ULS2, 450 dia @ 650 - run 01

Sheet No.
 Job No. 21495
 Made by : DBS
 Date: 1-10-2018
 Checked :

Units: kN,m

Stage No. 8 Fill to elevation 43.65 on RIGHT side with soil type 1

STABILITY ANALYSIS of Fully Embedded Wall according to Strength Factor method
 Factor of safety on soil strength

			Overall					
			FoS for toe		Toe elev. for			
			elev. = 40.75		FoS = 1.000			

Stage No.	--- G.L. Act.	--- Pass.	Strut Elev.	Factor of Safety	Moment of equil. at elev.	Toe elev.	Wall Penetr-ation	Direction of failure
8	48.30	43.65	48.21	1.785	n/a	42.57	1.08	L to R

BENDING MOMENT and DISPLACEMENT ANALYSIS of Fully Embedded Wall

Analysis options

Length of wall perpendicular to section = 50.00m

Subgrade reaction model - Boussinesq Influence coefficients

Soil deformations are elastic until the active or passive limit is reached

Open Tension Crack analysis - No

Rigid boundaries: Left side 50.00 from wall

Right side 50.00 from wall

Limit State: ULS DA1 Combination 2

Node no.	Y coord	Nett pressure kN/m ²	Wall disp. m	Wall rotation rad.	Shear force kN/m	Bending moment kN.m/m	Strut forces kN/m	EI of wall kN.m ² /m
1	49.75	0.00	-0.004	-3.26E-03	0.0	0.0		60696
2	49.38	0.00	-0.003	-3.26E-03	0.0	0.0		60696
3	49.00	0.00	-0.002	-3.26E-03	0.0	0.0		60696
4	48.65	0.00	-0.000	-3.26E-03	0.0	0.0		60696
5	48.30	0.00	0.001	-3.26E-03	0.0	0.0		60696
6	48.21	1.20	0.001	-3.26E-03	0.1	0.0	56.8	60696
		1.20	0.001	-3.26E-03	-56.7	0.0		
7	47.96	5.01	0.002	-3.23E-03	-55.9	-14.4		60696
8	47.70	9.20	0.003	-3.14E-03	-54.1	-28.4		60696
9	47.50	12.44	0.003	-3.03E-03	-52.0	-39.0		60696
		12.29	0.003	-3.03E-03	-52.0	-39.0		
10	47.00	20.00	0.005	-2.62E-03	-43.9	-62.0		60696
11	46.50	27.28	0.006	-2.03E-03	-32.1	-81.1		60696
12	46.00	34.34	0.007	-1.31E-03	-16.7	-93.9		60696
13	45.50	41.28	0.007	-5.24E-04	2.2	-97.1		60696
14	45.00	48.16	0.007	2.48E-04	24.6	-90.6		60696
		17.15	0.007	2.48E-04	24.6	-90.6		
15	44.50	20.00	0.007	9.35E-04	33.9	-76.2		60696
16	44.17	21.90	0.007	1.31E-03	40.7	-64.1		60696
17	43.85	23.85	0.006	1.61E-03	48.1	-49.7		60696
18	43.65	25.07	0.006	1.76E-03	53.0	-39.6		60696
19	43.19	26.98	0.005	1.95E-03	65.0	-10.0		60696
		-76.03	0.005	1.95E-03	65.0	-10.0		
20	43.00	-72.82	0.005	1.96E-03	50.9	0.9		60696
21	42.50	-63.73	0.004	1.89E-03	16.7	17.1		60696
22	42.00	-40.12	0.003	1.73E-03	-9.2	21.3		60696
23	41.50	-2.48	0.002	1.59E-03	-19.9	11.6		60696
24	41.13	26.06	0.001	1.54E-03	-15.5	4.0		60696
25	40.75	56.46	0.001	1.53E-03	0.0	0.0		---
At elev. 48.21			Strut force =		56.8 kN/strut =		56.8 kN/m run	

(continued)

Stage No.8 Fill to elevation 43.65 on RIGHT side with soil type 1

Node no.	Y coord	LEFT side					Total earth pressure kN/m2	Coeff. of subgrade reaction kN/m3
		Water press. kN/m2	Vertic -al kN/m2	Effective Active limit kN/m2	Effective Passive limit kN/m2	Earth pressure kN/m2		
1	49.75	0.00	0.00	0.00	0.00	0.00	0.00	0.0
2	49.38	0.00	0.00	0.00	0.00	0.00	0.00	0.0
3	49.00	0.00	0.00	0.00	0.00	0.00	0.00	0.0
4	48.65	0.00	0.00	0.00	0.00	0.00	0.00	0.0
5	48.30	0.00	0.00	0.00	0.00	0.00	0.00	0.0
		0.00	0.00	0.00	0.00	0.00	0.00	24141
6	48.21	0.88	0.77	0.32	2.05	0.32	1.20a	24141
7	47.96	3.38	3.95	1.62	10.53	1.62	5.01a	2970
8	47.70	5.89	8.09	3.32	21.54	3.32	9.20a	2970
9	47.50	7.85	11.19	4.59	29.80	4.59	12.44a	2970
		7.85	11.19	4.43	31.19	4.44	12.29	8556
10	47.00	12.75	18.25	7.22	50.88	7.25	20.00	8556
11	46.50	17.66	24.15	9.56	67.34	9.62	27.28	8556
12	46.00	22.56	29.44	11.65	82.08	11.77	34.34	8556
13	45.50	27.47	34.37	13.60	95.81	13.81	41.28	8556
14	45.00	32.37	39.06	15.45	108.90	15.79	48.16	8556
		Total>	71.44	16.50m	156.80	17.15	17.15	16780
15	44.50	Total>	81.38	19.00m	171.02	20.00	20.00	17619
16	44.17	Total>	87.79	20.63m	180.20	21.90	21.90	18164
17	43.85	Total>	94.16	22.25m	189.35	23.85	23.85	18710
18	43.65	Total>	98.07	23.25m	194.96	25.07	25.07	19045
19	43.19	Total>	107.03	25.55m	207.85	30.38	30.38	19817
20	43.00	Total>	110.72	26.50m	213.16	38.79	38.79	20136
21	42.50	Total>	120.41	29.00m	227.12	61.60	61.60	20975
22	42.00	Total>	130.09	31.50m	241.07	84.57	84.57	21814
23	41.50	Total>	139.76	34.00m	255.01	107.32	107.32	22653
24	41.13	Total>	147.02	35.87m	265.46	124.48	124.48	23282
25	40.75	Total>	154.27	37.75m	275.92	142.40	142.40	23911

Node no.	Y coord	RIGHT side					Total earth pressure kN/m2	Coeff. of subgrade reaction kN/m3
		Water press. kN/m2	Vertic -al kN/m2	Effective Active limit kN/m2	Effective Passive limit kN/m2	Earth pressure kN/m2		
1	49.75	0.00	0.00	0.00	0.00	0.00	0.00	0.0
2	49.38	0.00	0.00	0.00	0.00	0.00	0.00	0.0
3	49.00	0.00	0.00	0.00	0.00	0.00	0.00	0.0
4	48.65	0.00	0.00	0.00	0.00	0.00	0.00	0.0
5	48.30	0.00	0.00	0.00	0.00	0.00	0.00	0.0
6	48.21	0.00	0.00	0.00	0.00	0.00	0.00	0.0
7	47.96	0.00	0.00	0.00	0.00	0.00	0.00	0.0
8	47.70	0.00	0.00	0.00	0.00	0.00	0.00	0.0
9	47.50	0.00	0.00	0.00	0.00	0.00	0.00	0.0
10	47.00	0.00	0.00	0.00	0.00	0.00	0.00	0.0
11	46.50	0.00	0.00	0.00	0.00	0.00	0.00	0.0
12	46.00	0.00	0.00	0.00	0.00	0.00	0.00	0.0
13	45.50	0.00	0.00	0.00	0.00	0.00	0.00	0.0
14	45.00	0.00	0.00	0.00	0.00	0.00	0.00	0.0
15	44.50	0.00	0.00	0.00	0.00	0.00	0.00	0.0
16	44.17	0.00	0.00	0.00	0.00	0.00	0.00	0.0
17	43.85	0.00	0.00	0.00	0.00	0.00	0.00	0.0
18	43.65	0.00	0.00	0.00	0.00	0.00	0.00	0.0
		0.00	0.00	0.00	0.00	0.00	0.00	2970
19	43.19	0.00	8.28	3.40	22.06	3.40	3.40a	2970
		Total>	8.28	2.30m	109.09	106.41	106.41	19817

(continued)

Stage No.8 Fill to elevation 43.65 on RIGHT side with soil type 1

Node no.	Y coord	----- RIGHT side -----					Total earth pressure	Coeff. of subgrade reaction
		Water press. kN/m2	Vertical	Effective Active limit kN/m2	Effective Passive limit kN/m2	Earth pressure kN/m2		
20	43.00	Total>	12.08	3.25m	114.51	111.62	111.62	20136
21	42.50	Total>	22.08	5.75m	128.78	125.33	125.33	20975
22	42.00	Total>	32.08	8.25m	143.05	124.68	124.68	21814
23	41.50	Total>	42.08	10.75m	157.32	109.79	109.79	22653
24	41.13	Total>	49.59	12.63m	168.02	98.42	98.42	23282
25	40.75	Total>	57.09	14.50m	178.73	85.94	85.94	23911

Note: 3.40a Soil pressure at active limit
 123.45p Soil pressure at passive limit

Units: kN,m

Stage No.8 Fill to elev. 43.65 on RIGHT side

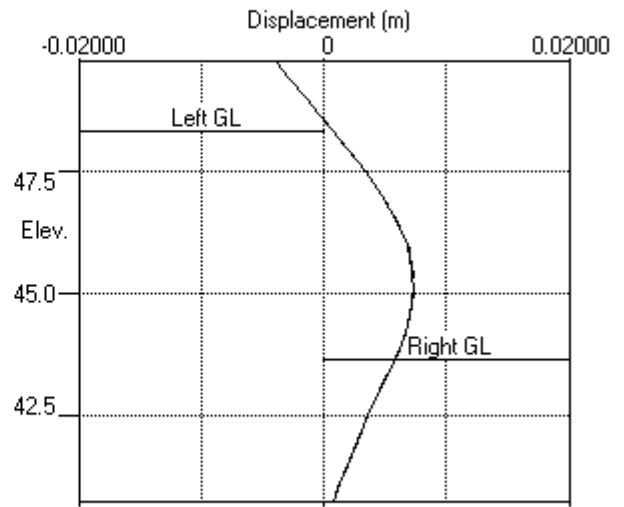
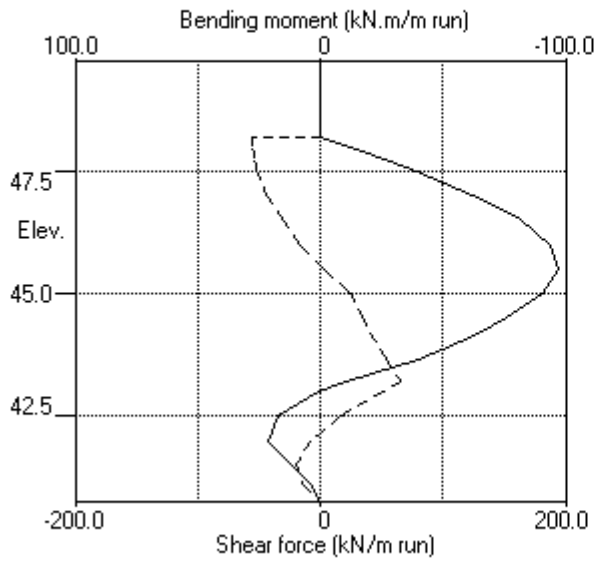

Stage No.8 Fill to elev. 43.65 on RIGHT side

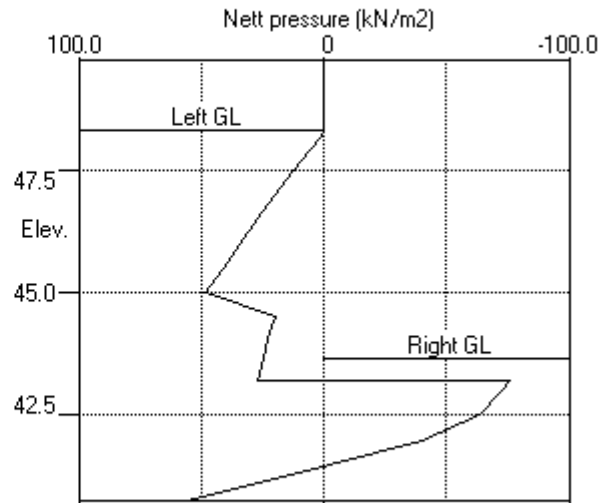
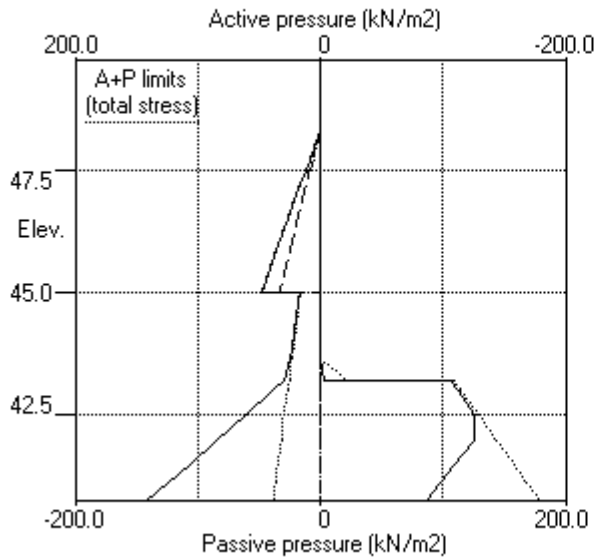

PILEDESIGNS LTD
 Program: WALLAP Version 6.06 Revision A51.B69.R54
 Licensed from GEOSOLVE
 Data filename/Run ID: Hampstead_Wall_4_450mm_rev_01_ULS2
 Hampstead - 24-26 Redington Gardens
 Wall 4, Secant-ULS2, 450 dia @ 650 - run 01

Sheet No.
 Job No. 21495
 Made by : DBS
 Date: 1-10-2018
 Checked :

Units: kN,m

Stage No. 10 Change EI of wall to 43355 kN.m2/m run
 Yield moment not defined
 Allow wall to relax with new modulus value

STABILITY ANALYSIS of Fully Embedded Wall according to Strength Factor method
 Factor of safety on soil strength

		Overall					
		FoS for toe		Toe elev. for			
		elev. = 40.75		FoS = 1.000			

Stage No.	--- G.L. --- Act. Pass.	Strut Elev.	Factor of Safety	Moment of equilib. at elev.	Toe elev.	Wall Penetr -ation	Direction of failure
10	48.30 43.65		More than one strut.	No FoS calc.			

BENDING MOMENT and DISPLACEMENT ANALYSIS of Fully Embedded Wall

Analysis options

Length of wall perpendicular to section = 50.00m
 Subgrade reaction model - Boussinesq Influence coefficients
 Soil deformations are elastic until the active or passive limit is reached
 Open Tension Crack analysis - No

Rigid boundaries: Left side 50.00 from wall
 Right side 50.00 from wall

Limit State: ULS DA1 Combination 2

Node no.	Y coord	Nett pressure kN/m2	Wall disp. m	Wall rotation rad.	Shear force kN/m	Bending moment kN.m/m	Strut forces kN/m	EI of wall kN.m2/m
1	49.75	0.00	-0.005	-3.70E-03	0.0	0.0		43355
2	49.38	0.00	-0.003	-3.70E-03	0.0	0.0		43355
3	49.00	0.00	-0.002	-3.70E-03	0.0	0.0		43355
4	48.65	0.00	-0.001	-3.70E-03	0.0	0.0		43355
5	48.30	0.00	0.001	-3.70E-03	0.0	0.0		43355
6	48.21	1.48	0.001	-3.70E-03	0.1	0.0	51.2	43355
		1.48	0.001	-3.70E-03	-51.2	0.0		
7	47.96	5.01	0.002	-3.67E-03	-50.3	-13.3		43355
8	47.70	9.20	0.003	-3.55E-03	-48.5	-26.2		43355
9	47.50	12.44	0.004	-3.41E-03	-46.4	-35.9		43355
		12.27	0.004	-3.41E-03	-46.4	-35.9		
10	47.00	19.97	0.005	-2.89E-03	-38.3	-56.7		43355
11	46.50	27.21	0.006	-2.16E-03	-26.5	-73.7		43355
12	46.00	34.21	0.007	-1.28E-03	-11.1	-84.3		43355
13	45.50	41.06	0.008	-3.41E-04	7.7	-85.4		43355
14	45.00	47.83	0.008	5.52E-04	29.9	-76.8		43355
		16.50	0.008	5.52E-04	29.9	-76.8		
15	44.50	19.00	0.007	1.29E-03	38.8	-60.4		43355
16	44.17	20.63	0.007	1.66E-03	45.2	-47.1		43355
17	43.85	23.41	0.006	1.91E-03	52.4	-31.6	20.2	43355
		23.41	0.006	1.91E-03	32.2	-31.6		
18	43.65	25.82	0.006	2.02E-03	37.1	-24.0		43355
19	43.19	30.12	0.005	2.11E-03	50.0	-0.1		43355
		-69.75	0.005	2.11E-03	50.0	-0.1		
20	43.00	-65.13	0.004	2.08E-03	37.2	8.8		43355
21	42.50	-54.14	0.003	1.89E-03	7.3	20.3		43355
22	42.00	-31.20	0.003	1.64E-03	-14.0	21.8		43355
23	41.50	3.64	0.002	1.45E-03	-20.9	11.2		43355
24	41.13	29.24	0.001	1.39E-03	-14.7	3.6		43355

(continued)

Stage No.10 Change EI of wall to 43355 kN.m2/m run
 Yield moment not defined
 Allow wall to relax with new modulus value

Node no.	Y coord	----- RIGHT side -----						
		Water press. kN/m2	Vertic -al kN/m2	Effective Active limit kN/m2	Effective Passive limit kN/m2	Earth pressure kN/m2	Total earth pressure kN/m2	Coeff. of subgrade reaction kN/m3
12	46.00	0.00	0.00	0.00	0.00	0.00	0.00	0.0
13	45.50	0.00	0.00	0.00	0.00	0.00	0.00	0.0
14	45.00	0.00	0.00	0.00	0.00	0.00	0.00	0.0
15	44.50	0.00	0.00	0.00	0.00	0.00	0.00	0.0
16	44.17	0.00	0.00	0.00	0.00	0.00	0.00	0.0
17	43.85	0.00	0.00	0.00	0.00	0.00	0.00	0.0
18	43.65	0.00	0.00	0.00	0.00	0.00	0.00	0.0
19	43.19	0.00	8.28	3.40	22.06	3.40	3.40a	3644
		Total>	8.28	2.30m	109.09	103.27	103.27	23931
20	43.00	Total>	12.08	3.25m	114.51	107.77	107.77	24316
21	42.50	Total>	22.08	5.75m	128.78	120.53	120.53	25329
22	42.00	Total>	32.08	8.25m	143.05	120.23	120.23	26342
23	41.50	Total>	42.08	10.75m	157.32	106.73	106.73	27355
24	41.13	Total>	49.59	12.63m	168.02	96.83	96.83	28115
25	40.75	Total>	57.09	14.50m	178.73	89.56	89.56	2635845

Note: 3.40a Soil pressure at active limit
 123.45p Soil pressure at passive limit

Units: kN,m

Stage No.10 Change EI of wall to 43355kN.m²/m run

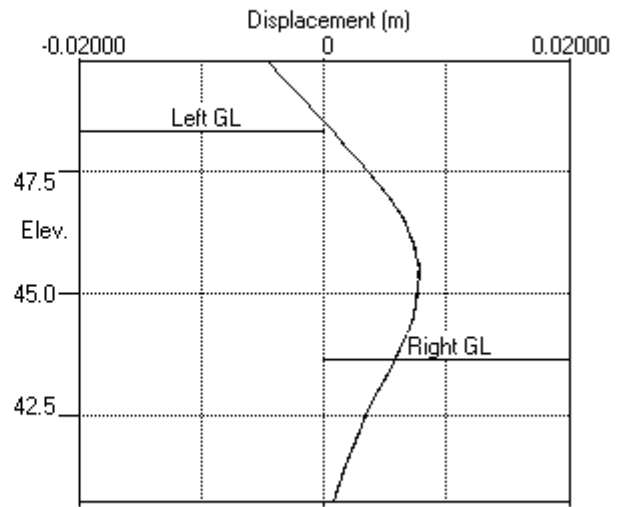
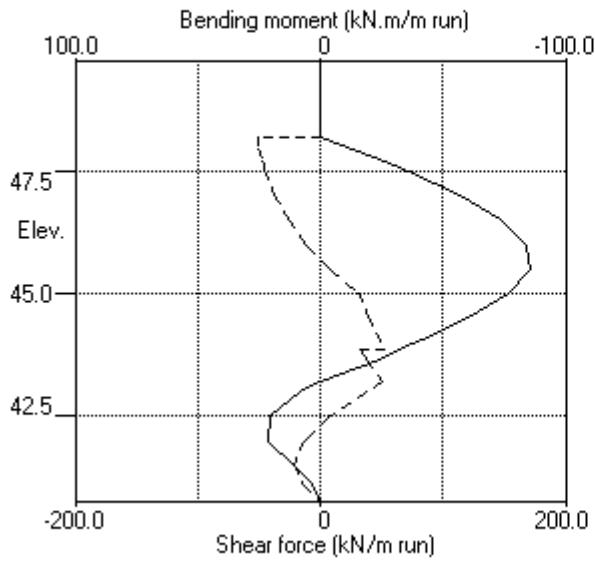

Stage No.10 Change EI of wall to 43355kN.m²/m run

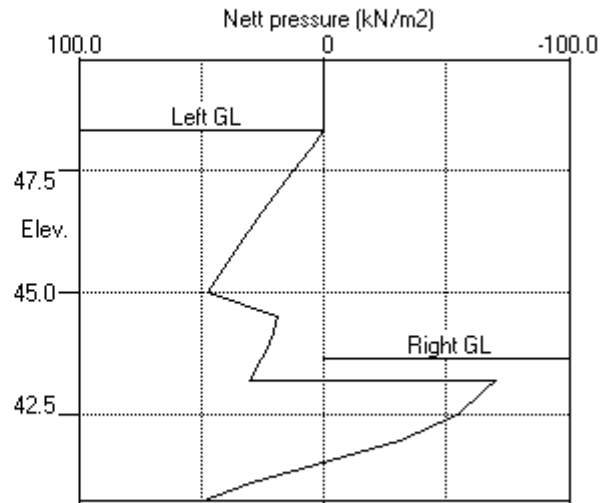
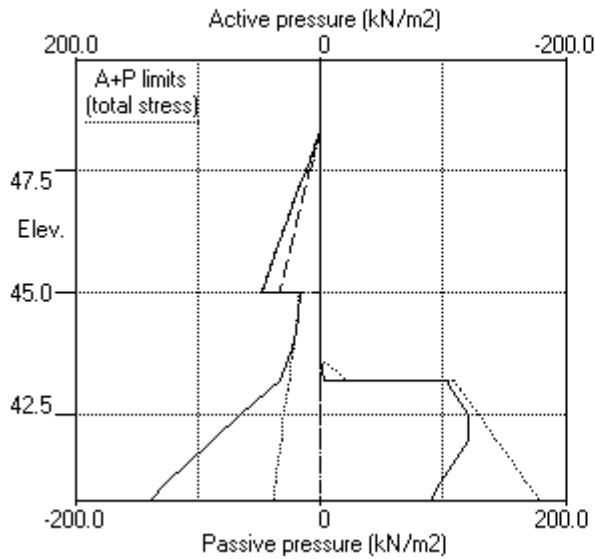

Units: kN,m

Stage No. 11 Change properties of soil type 3 to soil type 4
Ko pressures will not be reset

STABILITY ANALYSIS of Fully Embedded Wall according to Strength Factor method
Factor of safety on soil strength

		Overall					
		FoS for toe		Toe elev. for			
		elev. = 40.75		FoS = 1.000			
		-----		-----			
Stage	--- G.L. ---	Strut	Factor	Moment	Toe	Wall	Direction
No.	Act. Pass.	Elev.	of	equilib.	elev.	Penetr	of
			Safety	at elev.	-ation	-ation	failure
11	48.30 43.65		More than one strut.	No FoS calc.			

BENDING MOMENT and DISPLACEMENT ANALYSIS of Fully Embedded Wall
Analysis options

Length of wall perpendicular to section = 50.00m
Subgrade reaction model - Boussinesq Influence coefficients
Soil deformations are elastic until the active or passive limit is reached
Open Tension Crack analysis - No

Rigid boundaries: Left side 50.00 from wall
Right side 50.00 from wall

Limit State: ULS DA1 Combination 2

Node no.	Y coord	Nett pressure kN/m2	Wall disp. m	Wall rotation rad.	Shear force kN/m	Bending moment kN.m/m	Strut forces kN/m	EI of wall kN.m2/m
1	49.75	0.00	-0.003	-2.84E-03	0.0	0.0		43355
2	49.38	0.00	-0.002	-2.84E-03	0.0	0.0		43355
3	49.00	0.00	-0.001	-2.84E-03	0.0	0.0		43355
4	48.65	0.00	-0.000	-2.84E-03	0.0	0.0		43355
5	48.30	0.00	0.001	-2.84E-03	0.0	0.0		43355
6	48.21	1.50	0.001	-2.84E-03	0.1	0.0	44.1	43355
		1.50	0.001	-2.84E-03	-44.0	0.0		
7	47.96	5.67	0.002	-2.81E-03	-43.1	-11.4		43355
8	47.70	10.51	0.002	-2.71E-03	-41.1	-22.5		43355
9	47.50	14.23	0.003	-2.59E-03	-38.6	-30.7		43355
		17.44	0.003	-2.59E-03	-38.6	-30.7		
10	47.00	28.46	0.004	-2.16E-03	-27.1	-47.0		43355
11	46.50	38.53	0.005	-1.58E-03	-10.4	-57.3		43355
12	46.00	47.53	0.006	-9.41E-04	11.2	-58.4		43355
13	45.50	55.10	0.006	-3.70E-04	36.8	-46.7		43355
14	45.00	60.67	0.006	-1.72E-05	65.8	-21.8		43355
		48.98	0.006	-1.72E-05	65.8	-21.8		
15	44.50	56.03	0.006	-3.71E-05	92.0	16.8		43355
16	44.17	60.58	0.006	-3.20E-04	111.0	49.4		43355
17	43.85	65.13	0.006	-8.74E-04	131.4	88.4	232.0	43355
		65.13	0.006	-8.74E-04	-100.7	88.4		
18	43.65	67.92	0.007	-1.26E-03	-87.4	70.3		43355
19	43.19	60.09	0.007	-1.89E-03	-57.9	41.4		43355
		53.23	0.007	-1.89E-03	-57.9	41.4		
20	43.00	46.19	0.008	-2.06E-03	-48.5	31.8		43355
21	42.50	35.24	0.009	-2.34E-03	-28.1	13.6		43355
22	42.00	24.29	0.010	-2.47E-03	-13.2	7.1		43355
23	41.50	13.33	0.011	-2.52E-03	-3.8	1.9		43355
24	41.13	5.11	0.012	-2.53E-03	-0.4	0.6		43355
25	40.75	-3.11	0.013	-2.53E-03	-0.0	0.0		---
At elev. 48.21		Strut force =		44.1 kN/strut =		44.1 kN/m run		
At elev. 43.85		Strut force =		232.0 kN/strut =		232.0 kN/m run		

(continued)

Stage No.11 Change properties of soil type 3 to soil type 4
Ko pressures will not be reset

Node no.	Y coord	----- RIGHT side -----						Total earth pressure	Coeff. of subgrade reaction
		Water press.	Vertical	Effective Active limit	Effective Passive limit	Earth pressure	Earth pressure		
		kN/m2	kN/m2	kN/m2	kN/m2	kN/m2	kN/m2	kN/m3	
19	43.19	0.00	8.28	3.40	22.06	14.23	14.23	4228	
		0.00	8.28	3.52	21.09	21.09	21.09p	14813	
20	43.00	0.00	12.08	5.14	30.77	30.77	30.77p	15051	
21	42.50	4.90	17.18	7.30	43.75	43.75	48.66p	15678	
22	42.00	9.81	22.27	9.47	56.74	56.74	66.55p	16306	
23	41.50	14.71	27.37	11.63	69.72	69.72	84.43p	16933	
24	41.13	18.39	31.19	13.26	79.46	79.46	97.85p	17403	
25	40.75	22.07	35.02	14.89	89.20	89.20	111.28p	17873	

Note: 108.16a Soil pressure at active limit
111.28p Soil pressure at passive limit

Units: kN,m

Stage No.11 Change soil type 3 to soil type 4

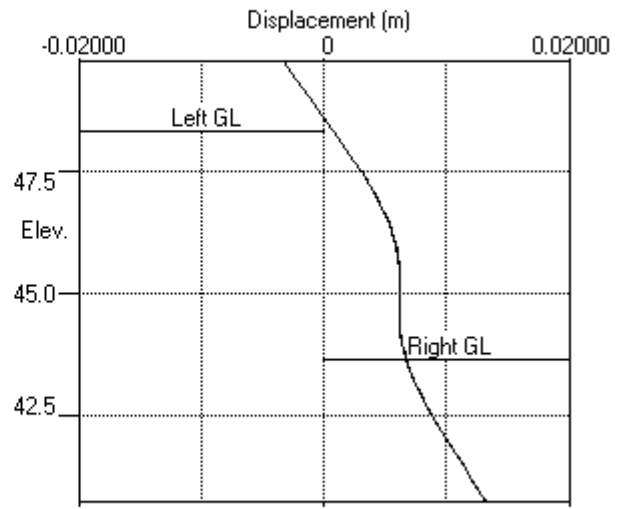
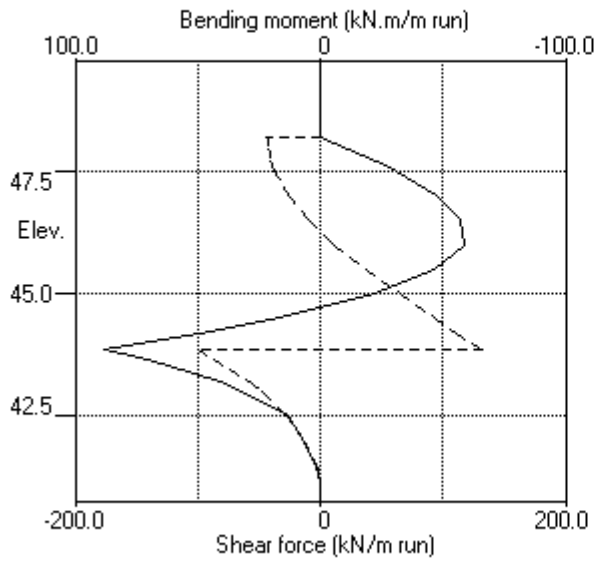

Stage No.11 Change soil type 3 to soil type 4

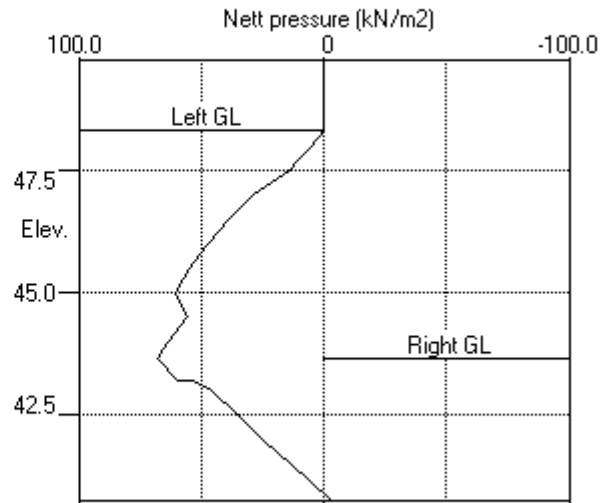
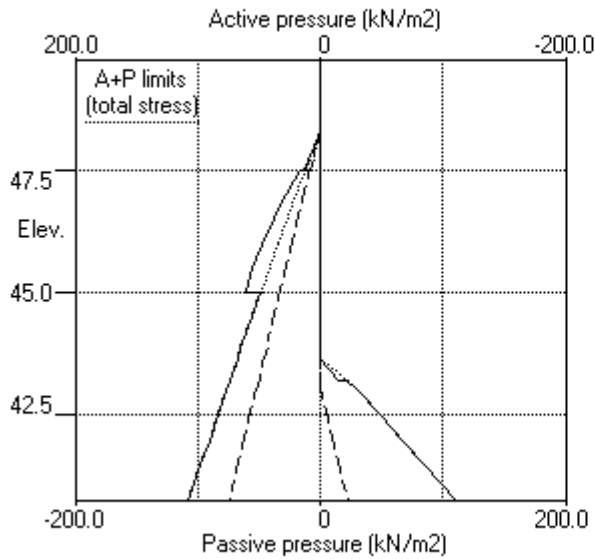

PILEDESIGNS LTD
 Program: WALLAP Version 6.06 Revision A51.B69.R54
 Licensed from GEOSOLVE
 Data filename/Run ID: Hampstead_Wall_4_450mm_rev_01_ULS2
 Hampstead - 24-26 Redington Gardens
 Wall 4, Secant-ULS2, 450 dia @ 650 - run 01

Sheet No.
 Job No. 21495
 Made by : DBS
 Date: 1-10-2018
 Checked :

Units: kN,m

Summary of results

LIMIT STATE PARAMETERS

Limit State: ULS DA1 Combination 2
 Water pressures : Worst Credible
 Partial factor on C' = 1.250
 Partial factor on Phi' = 1.250
 Partial factor on Cu = 1.400
 Partial factor on Soil Modulus = 1.000
 Partial factor on Permanent Unfavourable loads = 1.000
 Partial factor on Permanent Favourable loads = 1.000
 Partial factor on Variable Unfavourable loads = 1.300

STABILITY ANALYSIS of Fully Embedded Wall according to Strength Factor method

Factor of safety on soil strength

				Overall					
				FoS for toe		Toe elev. for			
				elev. = 40.75		FoS = 1.000			
				-----		-----			
Stage No.	--- G.L. Act.	--- Pass.	Strut Elev.	Factor of Safety	Moment at elev.	Toe elev.	Wall Penetr-ation	Direction of failure	
1	49.75	48.30	Cant.	2.711	41.78	45.46	2.84	R to L	
2	49.75	48.30	Cant.	3.617	41.88	46.16	2.14	R to L	
3	49.75	48.30	Cant.	3.805	41.86	46.35	1.95	R to L	
4	48.30	47.70	Cant.	4.176	41.64	46.07	1.63	L to R	
5	48.30	47.70		No analysis at this stage					
6	48.30	47.70	48.21	9.703	n/a	47.30	0.40	L to R	
7	48.30	43.19	48.21	1.686	n/a	42.47	0.72	L to R	
8	48.30	43.65	48.21	1.785	n/a	42.57	1.08	L to R	
9	48.30	43.65		No analysis at this stage					
All remaining stages have more than one strut - FoS calculation n/a									

PILEDESIGNS LTD
 Program: WALLAP Version 6.06 Revision A51.B69.R54
 Licensed from GEOSOLVE
 Data filename/Run ID: Hampstead_Wall_4_450mm_rev_01_ULS2
 Hampstead - 24-26 Redington Gardens
 Wall 4, Secant-ULS2, 450 dia @ 650 - run 01

Sheet No.
 Job No. 21495
 Made by : DBS
 Date: 1-10-2018
 Checked :

 Units: kN,m

Summary of results

BENDING MOMENT and DISPLACEMENT ANALYSIS of Fully Embedded Wall

Analysis options

Length of wall perpendicular to section = 50.00m
 Subgrade reaction model - Boussinesq Influence coefficients
 Soil deformations are elastic until the active or passive limit is reached
 Open Tension Crack analysis - No

Rigid boundaries: Left side 50.00 from wall
 Right side 50.00 from wall

Limit State: ULS DA1 Combination 2

Bending moment, shear force and displacement envelopes

Node no.	Y coord	Displacement		Bending moment		Shear force	
		maximum m	minimum m	maximum kN.m/m	minimum kN.m/m	maximum kN/m	minimum kN/m
1	49.75	0.001	-0.005	0.0	-0.0	0.0	0.0
2	49.38	0.001	-0.003	0.0	-0.1	0.0	-0.6
3	49.00	0.001	-0.003	0.0	-0.6	0.0	-2.3
4	48.65	0.001	-0.003	0.0	-1.8	0.0	-4.8
5	48.30	0.001	-0.002	0.0	-4.1	0.0	-8.3
6	48.21	0.001	-0.002	0.0	-4.9	0.1	-56.7
7	47.96	0.002	-0.002	0.1	-14.4	0.8	-55.9
8	47.70	0.003	-0.002	0.5	-28.4	2.7	-54.1
9	47.50	0.004	-0.002	1.2	-39.0	4.1	-52.0
10	47.00	0.005	-0.001	4.3	-62.0	3.1	-43.9
11	46.50	0.006	-0.001	5.2	-81.1	1.3	-32.1
12	46.00	0.007	-0.001	5.2	-93.9	11.2	-16.7
13	45.50	0.008	-0.001	5.3	-97.1	36.8	-2.0
14	45.00	0.008	-0.000	3.6	-90.6	65.8	-4.4
15	44.50	0.007	-0.000	16.8	-76.2	92.0	-3.3
16	44.17	0.007	-0.000	49.4	-64.1	111.0	-2.5
17	43.85	0.006	-0.000	88.4	-49.7	131.4	-100.7
18	43.65	0.007	-0.000	70.3	-39.6	53.0	-87.4
19	43.19	0.007	-0.000	43.5	-10.6	65.0	-57.9
20	43.00	0.008	-0.000	36.5	-1.3	50.9	-48.5
21	42.50	0.009	-0.000	20.8	-0.7	16.7	-28.1
22	42.00	0.010	-0.000	21.8	-0.4	0.5	-17.5
23	41.50	0.011	-0.000	11.6	-0.2	0.4	-20.9
24	41.13	0.012	-0.000	4.0	-0.1	0.3	-15.5
25	40.75	0.013	-0.000	0.0	-0.0	0.0	-0.0

Summary of results (continued)

Maximum and minimum bending moment and shear force at each stage

Stage no.	Bending moment				Shear force			
	maximum kN.m/m	elev.	minimum kN.m/m	elev.	maximum kN/m	elev.	minimum kN/m	elev.
1	0.5	42.00	-19.3	46.00	10.3	45.00	-10.9	47.70
2	0.1	41.50	-20.0	46.00	9.0	45.00	-11.1	47.70
3	0.1	41.50	-19.4	46.00	8.8	45.00	-10.8	47.96
4	5.3	45.50	-0.7	43.00	4.1	47.50	-4.4	45.00
5	No calculation at this stage							
6	1.6	43.65	-2.9	46.00	4.8	45.00	-4.3	48.21
7	20.5	42.00	-96.2	45.50	63.3	43.19	-56.3	48.21
8	21.3	42.00	-97.1	45.50	65.0	43.19	-56.7	48.21
9	No calculation at this stage							
10	21.8	42.00	-85.4	45.50	52.4	43.85	-51.2	48.21
11	88.4	43.85	-58.4	46.00	131.4	43.85	-100.7	43.85
12	No calculation at this stage							
13	71.9	43.85	-62.9	46.00	125.4	43.85	-65.6	43.85

Maximum and minimum displacement at each stage

Stage no.	Displacement				Stage description
	maximum m	elev.	minimum m	elev.	
1	0.000	49.75	-0.004	49.75	Excav. to elev. 48.30 on LEFT side
2	0.000	49.75	-0.004	49.75	Apply surcharge no.1 at elev. 48.30
3	0.000	49.75	-0.004	49.75	Apply water pressure profile no.1
4	0.001	49.75	0.000	49.75	Excav. to elev. 47.70 on RIGHT side
5	No calculation at this stage				Install strut no.1 at elev. 48.21
6	0.001	49.75	0.000	49.75	Apply water pressure profile no.2
7	0.007	45.00	-0.004	49.75	Excav. to elev. 43.19 on RIGHT side
8	0.007	45.00	-0.004	49.75	Fill to elev. 43.65 on RIGHT side
9	No calculation at this stage				Install strut no.2 at elev. 43.85
10	0.008	45.50	-0.005	49.75	Change EI of wall to 43355kN.m ² /m run
11	0.013	40.75	-0.003	49.75	Change soil type 3 to soil type 4
12	No calculation at this stage				Apply surcharge no.2 at elev. 43.65
13	0.012	40.75	-0.004	49.75	Apply water pressure profile no.3

Strut forces at each stage (horizontal components)

Stage no.	Strut no. 1		Strut no. 2	
	at elev. 48.21 kN/m run	kN/strut	at elev. 43.85 kN/m run	kN/strut
6	4.36	4.36	---	---
7	56.40	56.40	---	---
8	56.78	56.78	---	---
10	51.23	51.23	20.18	20.18
11	44.10	44.10	232.05	232.05
13	45.37	45.37	191.00	191.00

Units: kN,m

Bending moment, shear force, displacement envelopes

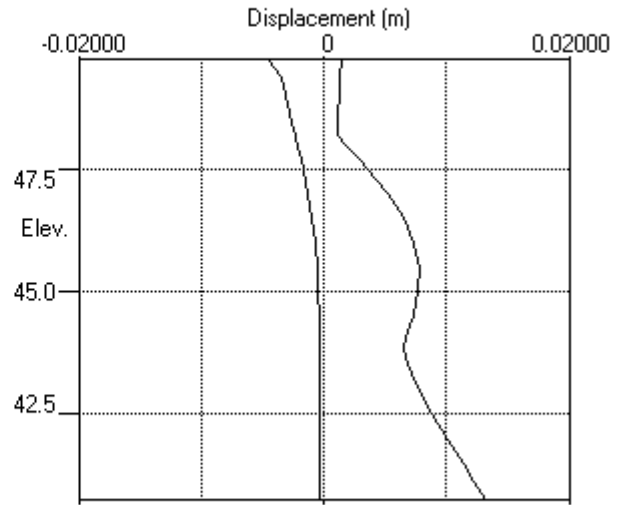
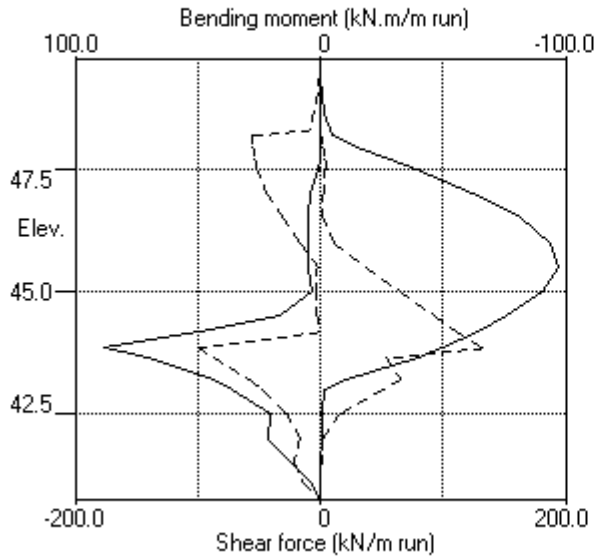



WALLAP

4-SLS

Units: kN,m

INPUT DATA

SOIL PROFILE

Stratum no.	Elevation of top of stratum	Soil types	
		Left side	Right side
1	49.75	1 Made Ground dr	1 Made Ground dr
2	47.50	2 Claygate Clay dr	2 Claygate Clay dr
3	45.00	3 London Clay und	3 London Clay und

SOIL PROPERTIES

-- Soil type --	Bulk density	Young's Modulus	At rest coeff.	Consol state.	Active limit	Passive limit	Cohesion
No. Description (Datum elev.)	kN/m3	Eh,kN/m2 (dEh/dy)	Ko (dKo/dy)	NC/OC (Nu)	Ka (Kac)	Kp (Kpc)	kN/m2 (dc/dy)
1 Made Ground dr	18.00	10000	0.530	OC (0.250)	0.337 (0.000)	3.442 (0.000)	
2 Claygate Clay dr	19.00	30000	1.000	NC (0.200)	0.323 (1.330)	3.647 (5.195)	0.0d
3 London Cl.. (45.00)	20.00	40000 (4000)	1.000	OC (0.490)	1.000 (2.476)	1.000 (2.390)	50.00u (5.000)
4 London Cl.. (45.00)	20.00	30800 (3080)	1.000	OC (0.200)	0.351 (1.391)	3.253 (4.831)	0.0d

Additional soil parameters associated with Ka and Kp

No. Description	--- parameters for Ka ---			--- parameters for Kp ---		
	Soil friction angle	Wall adhesion coeff.	Back-fill angle	Soil friction angle	Wall adhesion coeff.	Back-fill angle
1 Made Ground dr	26.00	0.670	0.00	26.00	0.500	0.00
2 Claygate Clay dr	27.00	0.670	0.00	27.00	0.500	0.00
3 London Clay und	0.00	0.670	0.00	0.00	0.500	0.00
4 London Clay dr	25.00	0.670	0.00	25.00	0.500	0.00

GROUND WATER CONDITIONS

Density of water = 9.810 kN/m3

	Left side	Right side
Initial water table elevation	48.30	48.30

Automatic water pressure balancing at toe of wall : No

Water profile no.	Left side				Right side			
	Point no.	Elev. m	Piezo elev. m	Water press. kN/m2	Point no.	Elev. m	Piezo elev. m	Water press. kN/m2
1	1	48.30	48.30	0.0	1	47.50	47.50	0.0 MC+WC
2	1	48.30	48.30	0.0	1	43.00	43.00	0.0 MC+WC
3	1	48.30	48.30	0.0	1	43.65	43.65	0.0 MC+WC
					2	43.65	48.30	45.6

WALL PROPERTIES

Type of structure = Fully Embedded Wall
 Elevation of toe of wall = 40.75
 Maximum finite element length = 0.50 m
 Youngs modulus of wall E = 1.9600E+07 kN/m2
 Moment of inertia of wall I = 3.0968E-03 m4/m run
 E.I = 60696 kN.m2/m run
 Yield Moment of wall = Not defined

STRUTS and ANCHORS

Strut/ anchor no.	Elev.	Strut spacing m	X-section area of strut sq.m	Youngs modulus kN/m ²	Free length m	Inclin -ation (degs)	Pre- stress /strut kN	Tension allowed
1	48.21	1.00	0.400000	1.400E+07	5.00	0.00	0	No
2	43.85	1.00	0.300000	1.400E+07	5.00	0.00	0	No

SURCHARGE LOADS

Surch -arge no.	Elev.	Distance from wall	Length parallel to wall	Width perpend. to wall	Surcharge ----- kN/m ² ----- Near edge Far edge		Equiv. soil type	Partial factor/ Category
1	48.30	0.50(L)	10.00	10.00	10.00	=	N/A	1.00 Var
2	43.65	-0.00(R)	10.00	10.00	46.00	=	N/A	1.00 P/F

Note: L = Left side, R = Right side

Limit State Categories P/U = Permanent Unfavourable
P/F = Permanent Favourable
Var = Variable (unfavourable)

CONSTRUCTION STAGES

Construction stage no.	Stage description
1	Excavate to elevation 48.30 on LEFT side
2	Apply surcharge no.1 at elevation 48.30
3	Apply water pressure profile no.1 (Mod. Conserv.)
4	Excavate to elevation 47.70 on RIGHT side
5	Install strut or anchor no.1 at elevation 48.21
6	Apply water pressure profile no.2 (Mod. Conserv.)
7	Excavate to elevation 43.65 on RIGHT side
8	Install strut or anchor no.2 at elevation 43.85
9	Change EI of wall to 43355 kN.m ² /m run Yield moment not defined Allow wall to relax with new modulus value
10	Change properties of soil type 3 to soil type 4 Ko pressures will not be reset
11	Apply surcharge no.2 at elevation 43.65 No analysis at this stage
12	Apply water pressure profile no.3 (Mod. Conserv.)

FACTORS OF SAFETY and ANALYSIS OPTIONS

Limit State options: Serviceability Limit State
All loads and soil strengths are unfactored

Stability analysis:

Method of analysis - Strength Factor method
Factor on soil strength for calculating wall depth = 1.50

Parameters for undrained strata:

Minimum equivalent fluid density = 5.00 kN/m³
Maximum depth of water filled tension crack = 0.00 m

Bending moment and displacement calculation:

Method - Subgrade reaction model using Influence Coefficients
Open Tension Crack analysis? - No
Non-linear Modulus Parameter (L) = 9.000 m

Boundary conditions:

Length of wall (normal to plane of analysis) = 50.00 m

Width of excavation on Left side of wall = 50.00 m
Width of excavation on Right side of wall = 50.00 m

Distance to rigid boundary on Left side = 50.00 m
Distance to rigid boundary on Right side = 50.00 m

OUTPUT OPTIONS

Stage no.	Stage description	Output options		
		Displacement	Active, Graph.	Passive output
		Bending mom.	pressures	
		Shear force		
1	Excav. to elev. 48.30 on LEFT side	Yes	Yes	Yes
2	Apply surcharge no.1 at elev. 48.30	No	No	No
3	Apply water pressure profile no.1	Yes	Yes	Yes
4	Excav. to elev. 47.70 on RIGHT side	Yes	Yes	Yes
5	Install strut no.1 at elev. 48.21	Yes	Yes	Yes
6	Apply water pressure profile no.2	Yes	Yes	Yes
7	Excav. to elev. 43.65 on RIGHT side	Yes	Yes	Yes
8	Install strut no.2 at elev. 43.85	Yes	Yes	Yes
9	Change EI of wall to 43355kN.m ² /m run	No	No	No
10	Change soil type 3 to soil type 4	No	No	No
11	Apply surcharge no.2 at elev. 43.65	No	No	No
12	Apply water pressure profile no.3	No	No	No
*	Summary output	Yes	-	Yes

Program WALLAP - Copyright (C) 2017 by DL Borin, distributed by GEOSOLVE
 150 St. Alphonsus Road, London SW4 7BW, UK www.geosolve.co.uk

Units: kN,m

Stage No.12 Apply water pressure profile no.3 (Mod. Conserv.)

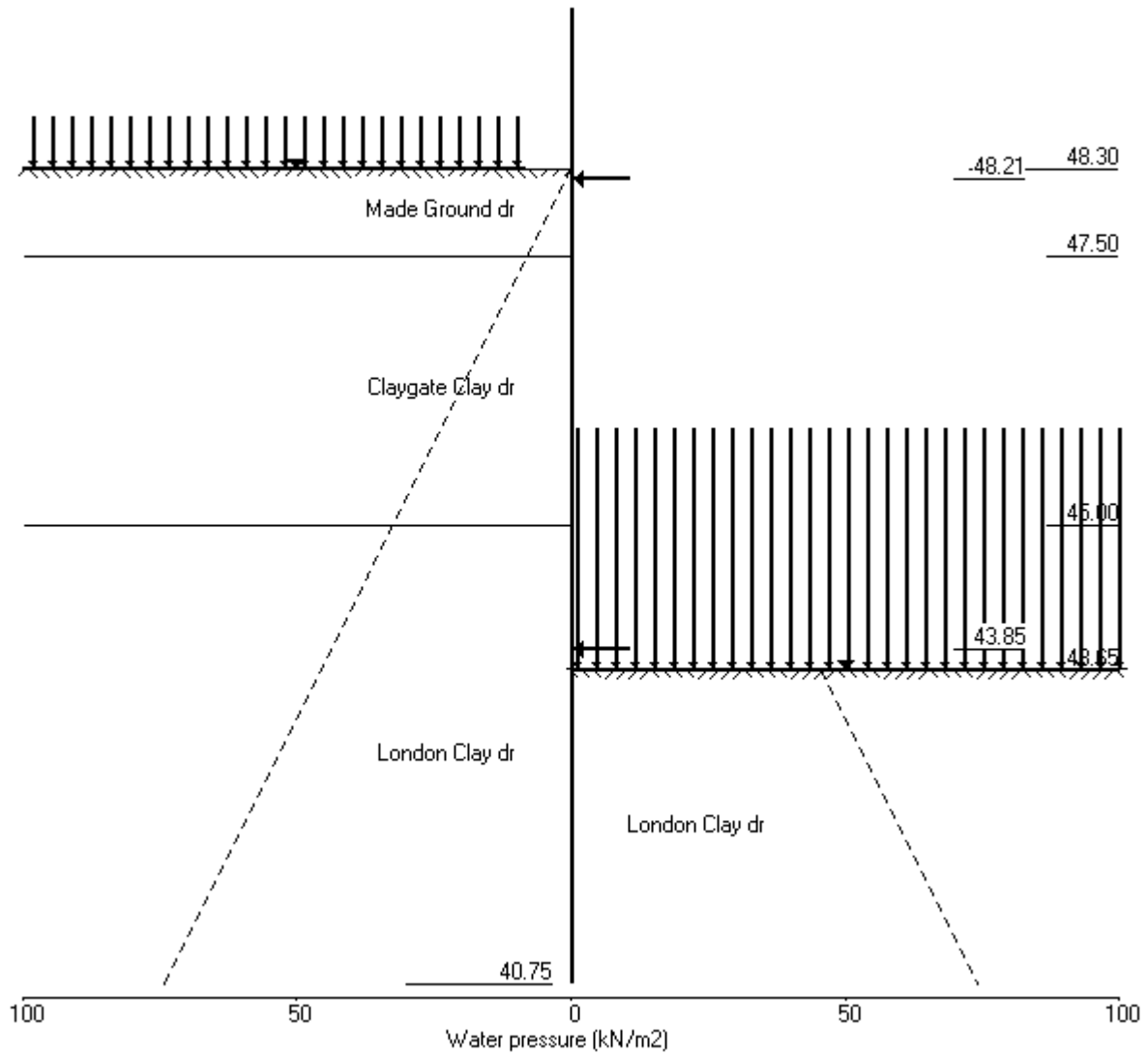

PILEDESIGNS LTD
 Program: WALLAP Version 6.06 Revision A51.B69.R54
 Licensed from GEOSOLVE
 Data filename/Run ID: Hampstead_Wall_4_450mm_rev_01_SLS
 Hampstead - 24-26 Redington Gardens
 Wall 4, Secant-SLS, 450 dia @ 650 - run 01

Sheet No.
 Job No. 21495
 Made by : DBS
 Date: 1-10-2018
 Checked :

Units: kN,m

Stage No. 1 Excavate to elevation 48.30 on LEFT side

STABILITY ANALYSIS of Fully Embedded Wall according to Strength Factor method
 Factor of safety on soil strength

Stage No.	--- G.L. --- Act.	--- G.L. --- Pass.	Strut Elev.	FoS for toe elev. =	Moment of equil. at elev.	Toe elev. for FoS =	Wall Penetr-ation	Direction of failure
1	49.75	48.30	Cant.	3.598	41.81	44.66	3.64	R to L

BENDING MOMENT and DISPLACEMENT ANALYSIS of Fully Embedded Wall

Analysis options

Length of wall perpendicular to section = 50.00m
 Subgrade reaction model - Boussinesq Influence coefficients
 Soil deformations are elastic until the active or passive limit is reached
 Open Tension Crack analysis - No

Rigid boundaries: Left side 50.00 from wall
 Right side 50.00 from wall

Limit State: Serviceability Limit State

Calculated Bending Moments and Strut Forces are to be multiplied by a factor of 1.35 to obtain values for structural design. See summary for factored values.

Node no.	Y coord	Nett pressure kN/m2	Wall disp. m	Wall rotation rad.	Shear force kN/m	Bending moment kN.m/m	Strut forces kN/m	EI of wall kN.m2/m
1	49.75	0.00	-0.002	-5.94E-04	0.0	-0.0		60696
2	49.38	-2.27	-0.002	-5.94E-04	-0.4	-0.1		60696
3	49.00	-4.54	-0.002	-5.92E-04	-1.7	-0.4		60696
4	48.65	-6.67	-0.002	-5.87E-04	-3.7	-1.3		60696
5	48.30	-8.79	-0.001	-5.74E-04	-6.4	-3.1		60696
6	48.21	-6.51	-0.001	-5.69E-04	-7.1	-3.7		60696
7	47.96	-0.94	-0.001	-5.50E-04	-8.0	-5.6		60696
8	47.70	0.39	-0.001	-5.22E-04	-8.1	-7.7		60696
9	47.50	-0.41	-0.001	-4.93E-04	-8.1	-9.4		60696
		2.22	-0.001	-4.93E-04	-8.1	-9.4		
10	47.00	12.05	-0.001	-4.03E-04	-4.5	-12.6		60696
11	46.50	8.38	-0.001	-2.94E-04	0.6	-13.8		60696
12	46.00	5.66	-0.001	-1.86E-04	4.1	-12.4		60696
13	45.50	4.09	-0.000	-9.58E-05	6.5	-9.7		60696
14	45.00	3.40	-0.000	-3.17E-05	8.4	-5.9		60696
		-6.06	-0.000	-3.17E-05	8.4	-5.9		
15	44.50	-5.38	-0.000	2.65E-06	5.5	-2.4		60696
16	44.17	-4.65	-0.000	1.16E-05	3.9	-0.9		60696
17	43.85	-3.83	-0.000	1.39E-05	2.5	0.1		60696
18	43.65	-3.32	-0.000	1.28E-05	1.8	0.5		60696
19	43.33	-2.51	-0.000	8.90E-06	0.9	0.9		60696
20	43.00	-1.77	-0.000	3.41E-06	0.2	1.1		60696
21	42.50	-0.83	-0.000	-5.12E-06	-0.5	1.0		60696
22	42.00	-0.09	-0.000	-1.17E-05	-0.7	0.6		60696
23	41.50	0.47	-0.000	-1.54E-05	-0.6	0.3		60696
24	41.13	0.82	-0.000	-1.65E-05	-0.4	0.1		60696
25	40.75	1.13	-0.000	-1.68E-05	-0.0	0.0		---

(continued)

Stage No.1 Excavate to elevation 48.30 on LEFT side

Node no.	Y coord	Effective stresses					Total earth pressure	Coeff. of subgrade reaction
		Water press. kN/m2	Vertic -al kN/m2	Active limit kN/m2	Passive limit kN/m2	Earth pressure kN/m2		
1	49.75	0.00	0.00	0.00	0.00	0.00	0.00	0.0
2	49.38	0.00	0.00	0.00	0.00	0.00	0.00	0.0
3	49.00	0.00	0.00	0.00	0.00	0.00	0.00	0.0
4	48.65	0.00	0.00	0.00	0.00	0.00	0.00	0.0
5	48.30	0.00	0.00	0.00	0.00	0.00	0.00	0.0
		0.00	0.00	0.00	0.00	0.00	0.00	4238
6	48.21	0.88	0.74	0.25	2.54	2.54	3.42p	4238
7	47.96	3.38	2.83	0.95	9.73	9.73	13.11p	4238
8	47.70	5.89	4.91	1.65	16.92	12.66	18.55	4238
9	47.50	7.85	6.55	2.21	22.55	13.10	20.94	4238
		7.85	6.55	2.11	23.89	23.89	31.74p	12248
10	47.00	12.75	11.15	3.60	40.65	40.65	53.41p	12248
11	46.50	17.66	15.74	5.08	57.41	43.39	61.05	12248
12	46.00	22.56	20.34	6.56	74.17	46.52	69.08	12248
13	45.50	27.47	24.93	8.04	90.93	50.26	77.72	12248
14	45.00	32.37	29.53	9.53	107.69	54.48	86.85	12248
		Total>	61.90	16.50m	181.40	73.17	73.17	23347
15	44.50	Total>	71.90	19.00m	197.38	83.54	83.54	24515
16	44.17	Total>	78.41	20.63m	207.76	90.43	90.43	25273
17	43.85	Total>	84.91	22.25m	218.15	97.38	97.38	26032
18	43.65	Total>	88.91	23.25m	224.54	101.65	101.65	26499
19	43.33	Total>	95.41	24.87m	234.92	108.59	108.59	27258
20	43.00	Total>	101.91	26.50m	245.31	115.49	115.49	28017
21	42.50	Total>	111.92	29.00m	261.29	126.00	126.00	29184
22	42.00	Total>	121.92	31.50m	277.27	136.39	136.39	30351
23	41.50	Total>	131.93	34.00m	293.25	146.70	146.70	31519
24	41.13	Total>	139.43	35.87m	305.23	154.39	154.39	32394
25	40.75	Total>	146.94	37.75m	317.22	162.06	162.06	33270

Node no.	Y coord	Effective stresses					Total earth pressure	Coeff. of subgrade reaction
		Water press. kN/m2	Vertic -al kN/m2	Active limit kN/m2	Passive limit kN/m2	Earth pressure kN/m2		
1	49.75	0.00	0.00	0.00	0.00	0.00	0.00	3589
2	49.38	0.00	6.75	2.27	23.24	2.27	2.27a	3589
3	49.00	0.00	13.50	4.54	46.47	4.54	4.54a	3589
4	48.65	0.00	19.80	6.67	68.16	6.67	6.67a	3589
5	48.30	0.00	26.10	8.79	89.84	8.79	8.79a	3589
6	48.21	0.88	26.84	9.04	92.38	9.05	9.93	3589
7	47.96	3.38	28.93	9.74	99.57	10.67	14.06	3589
8	47.70	5.89	31.01	10.44	106.76	12.27	18.16	3589
9	47.50	7.85	32.65	10.99	112.40	13.50	21.35	3589
		7.85	32.65	10.53	119.08	21.67	29.52	10360
10	47.00	12.75	37.25	12.02	135.84	28.61	41.36	10360
11	46.50	17.66	41.84	13.50	152.59	35.01	52.67	10360
12	46.00	22.56	46.44	14.98	169.35	40.85	63.41	10360
13	45.50	27.47	51.03	16.46	186.11	46.17	73.64	10360
14	45.00	32.37	55.63	17.94	202.86	51.08	83.45	10360
		Total>	88.00	23.75m	207.50	79.23	79.23	19981
15	44.50	Total>	98.00	26.25m	223.47	88.92	88.92	20980
16	44.17	Total>	104.50	27.88m	233.86	95.08	95.08	21630
17	43.85	Total>	111.00	29.50m	244.24	101.21	101.21	22279
18	43.65	Total>	115.00	30.50m	250.63	104.97	104.97	22679

(continued)

Stage No.1 Excavate to elevation 48.30 on LEFT side

Node no.	Y coord	----- RIGHT side -----					Total earth pressure	Coeff. of subgrade reaction
		Water press. kN/m2	Vertic -al kN/m2	Effective Active limit kN/m2	Effective Passive limit kN/m2	Earth pressure kN/m2		
19	43.33	Total>	121.50	32.12m	261.01	111.10	111.10	23328
20	43.00	Total>	128.00	33.75m	271.40	117.26	117.26	23977
21	42.50	Total>	138.00	36.25m	287.37	126.82	126.82	24977
22	42.00	Total>	148.00	38.75m	303.35	136.49	136.49	25976
23	41.50	Total>	158.00	41.25m	319.32	146.23	146.23	26975
24	41.13	Total>	165.50	43.13m	331.30	153.57	153.57	27724
25	40.75	Total>	173.00	45.00m	343.28	160.93	160.93	28473

Note: 8.79a Soil pressure at active limit
 53.41p Soil pressure at passive limit

Units: kN,m

Stage No.1 Excav. to elev. 48.30 on LEFT side

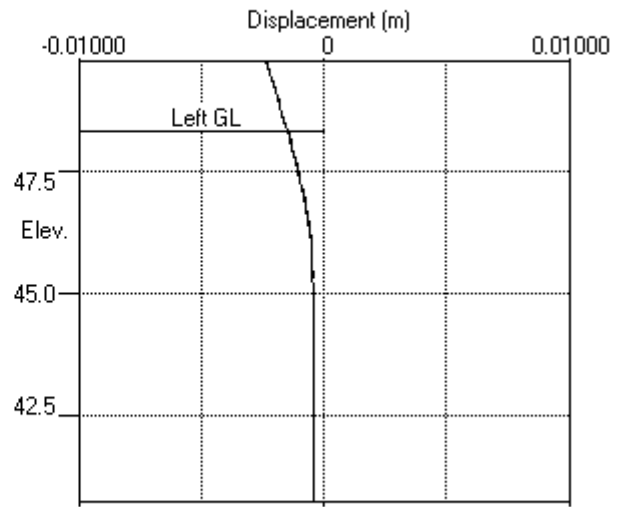
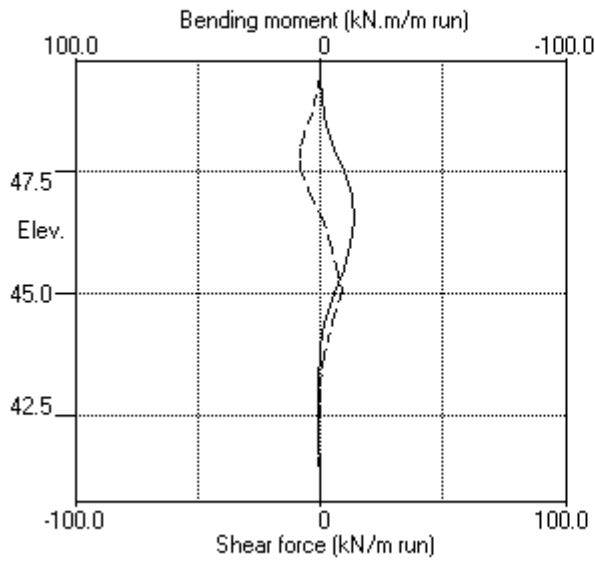

Stage No.1 Excav. to elev. 48.30 on LEFT side

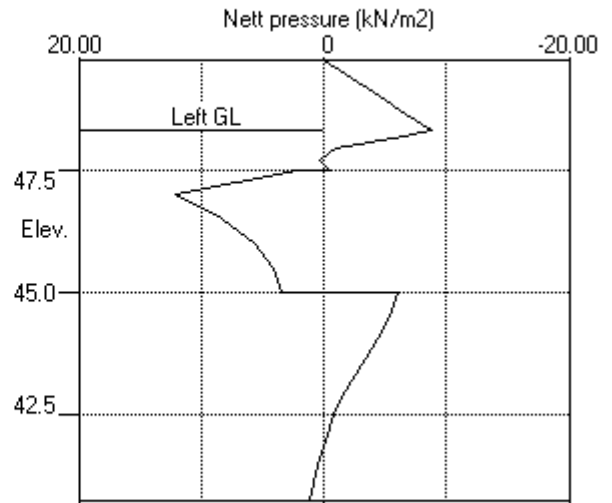
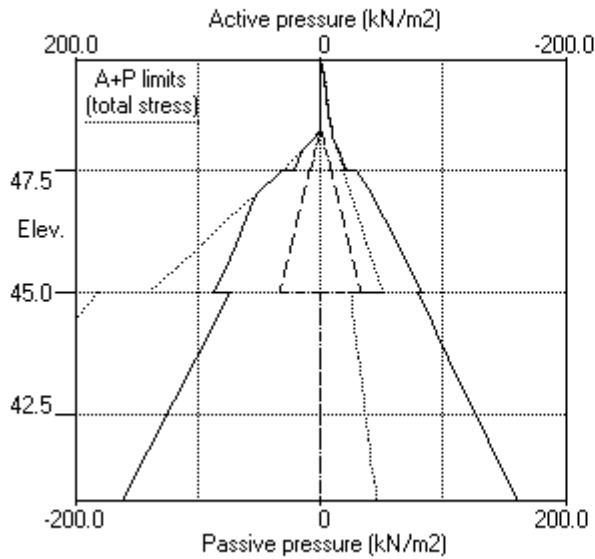

PILEDESIGNS LTD
 Program: WALLAP Version 6.06 Revision A51.B69.R54
 Licensed from GEOSOLVE
 Data filename/Run ID: Hampstead_Wall_4_450mm_rev_01_SLS
 Hampstead - 24-26 Redington Gardens
 Wall 4, Secant-SLS, 450 dia @ 650 - run 01

Sheet No.
 Job No. 21495
 Made by : DBS
 Date: 1-10-2018
 Checked :

Units: kN,m

Stage No. 4 Excavate to elevation 47.70 on RIGHT side

STABILITY ANALYSIS of Fully Embedded Wall according to Strength Factor method
 Factor of safety on soil strength

Stage No.	--- G.L. --- Act.	--- G.L. --- Pass.	Strut Elev.	FoS for toe elev. =	Moment of equil. at elev.	Toe elev. for FoS =	Wall Penetr-ation	Direction of failure
4	48.30	47.70	Cant.	6.146	41.68	45.59	2.11	L to R

BENDING MOMENT and DISPLACEMENT ANALYSIS of Fully Embedded Wall

Analysis options

Length of wall perpendicular to section = 50.00m
 Subgrade reaction model - Boussinesq Influence coefficients
 Soil deformations are elastic until the active or passive limit is reached
 Open Tension Crack analysis - No

Rigid boundaries: Left side 50.00 from wall
 Right side 50.00 from wall

Limit State: Serviceability Limit State

Calculated Bending Moments and Strut Forces are to be multiplied by a factor of 1.35 to obtain values for structural design. See summary for factored values.

Node no.	Y coord	Nett pressure kN/m2	Wall disp. m	Wall rotation rad.	Shear force kN/m	Bending moment kN.m/m	Strut forces kN/m	EI of wall kN.m2/m
1	49.75	0.00	0.001	2.57E-04	0.0	0.0		60696
2	49.38	0.00	0.001	2.57E-04	0.0	0.0		60696
3	49.00	0.00	0.001	2.57E-04	0.0	0.0		60696
4	48.65	0.00	0.001	2.57E-04	0.0	0.0		60696
5	48.30	0.00	0.001	2.57E-04	0.0	0.0		60696
6	48.21	1.14	0.001	2.57E-04	0.1	0.0		60696
7	47.96	4.63	0.001	2.57E-04	0.8	0.1		60696
8	47.70	11.14	0.001	2.56E-04	2.8	0.6		60696
9	47.50	2.96	0.001	2.53E-04	4.2	1.3		60696
		-2.02	0.001	2.53E-04	4.2	1.3		
10	47.00	2.57	0.001	2.30E-04	4.3	4.1		60696
11	46.50	-7.62	0.001	1.89E-04	3.1	5.8		60696
12	46.00	-6.16	0.000	1.37E-04	-0.4	6.9		60696
13	45.50	-4.31	0.000	8.45E-05	-3.0	5.9		60696
14	45.00	-3.23	0.000	4.40E-05	-4.9	3.9		60696
		2.60	0.000	4.40E-05	-4.9	3.9		
15	44.50	2.87	0.000	2.05E-05	-3.5	1.8		60696
16	44.17	2.70	0.000	1.36E-05	-2.6	0.8		60696
17	43.85	2.38	0.000	1.12E-05	-1.8	0.1		60696
18	43.65	2.14	0.000	1.13E-05	-1.3	-0.2		60696
19	43.33	1.70	0.000	1.33E-05	-0.7	-0.5		60696
20	43.00	1.26	0.000	1.64E-05	-0.2	-0.7		60696
21	42.50	0.64	0.000	2.17E-05	0.3	-0.6		60696
22	42.00	0.12	0.000	2.60E-05	0.5	-0.4		60696
23	41.50	-0.30	0.000	2.84E-05	0.4	-0.2		60696
24	41.13	-0.56	0.000	2.91E-05	0.3	-0.1		60696
25	40.75	-0.79	0.000	2.93E-05	0.0	-0.0		---

(continued)

Stage No.4 Excavate to elevation 47.70 on RIGHT side

Node no.	Y coord	LEFT side					Total earth pressure kN/m2	Coeff. of subgrade reaction kN/m3
		Water press. kN/m2	Vertic -al kN/m2	Effective Active limit kN/m2	Effective Passive limit kN/m2	Earth pressure kN/m2		
1	49.75	0.00	0.00	0.00	0.00	0.00	0.00	0.0
2	49.38	0.00	0.00	0.00	0.00	0.00	0.00	0.0
3	49.00	0.00	0.00	0.00	0.00	0.00	0.00	0.0
4	48.65	0.00	0.00	0.00	0.00	0.00	0.00	0.0
5	48.30	0.00	0.00	0.00	0.00	0.00	0.00	0.0
		0.00	0.00	0.00	0.00	0.00	0.00	4222
6	48.21	0.88	0.76	0.26	2.62	0.26	1.14a	4222
7	47.96	3.38	3.69	1.24	12.71	1.24	4.63a	4222
8	47.70	5.89	7.35	2.48	25.31	5.25	11.14	4222
9	47.50	7.85	10.12	3.41	34.83	6.73	14.58	4222
		7.85	10.12	3.26	36.90	3.26	11.11a	12201
10	47.00	12.75	16.61	5.36	60.58	24.60	37.36	12201
11	46.50	17.66	22.21	7.17	81.01	31.18	48.83	12201
12	46.00	22.56	27.34	8.82	99.70	37.05	59.61	12201
13	45.50	27.47	32.19	10.38	117.39	42.51	69.98	12201
14	45.00	32.37	36.86	11.89	134.43	47.62	79.99	12201
		Total>	69.24	16.50m	188.73	63.41	63.41	23263
15	44.50	Total>	79.20	19.00m	204.67	73.56	73.56	24427
16	44.17	Total>	85.62	20.63m	214.98	79.98	79.98	25183
17	43.85	Total>	92.03	22.25m	225.27	86.32	86.32	25939
18	43.65	Total>	95.96	23.25m	231.59	90.19	90.19	26404
19	43.33	Total>	102.33	24.87m	241.84	96.45	96.45	27160
20	43.00	Total>	108.69	26.50m	252.08	102.70	102.70	27916
21	42.50	Total>	118.45	29.00m	267.82	112.33	112.33	29079
22	42.00	Total>	128.21	31.50m	283.55	121.99	121.99	30242
23	41.50	Total>	137.95	34.00m	299.28	131.69	131.69	31406
24	41.13	Total>	145.27	35.87m	311.07	138.99	138.99	32278
25	40.75	Total>	152.58	37.75m	322.86	146.30	146.30	33150

Node no.	Y coord	RIGHT side					Total earth pressure kN/m2	Coeff. of subgrade reaction kN/m3
		Water press. kN/m2	Vertic -al kN/m2	Effective Active limit kN/m2	Effective Passive limit kN/m2	Earth pressure kN/m2		
1	49.75	0.00	0.00	0.00	0.00	0.00	0.00	0.0
2	49.38	0.00	0.00	0.00	0.00	0.00	0.00	0.0
3	49.00	0.00	0.00	0.00	0.00	0.00	0.00	0.0
4	48.65	0.00	0.00	0.00	0.00	0.00	0.00	0.0
5	48.30	0.00	0.00	0.00	0.00	0.00	0.00	0.0
6	48.21	0.00	0.00	0.00	0.00	0.00	0.00	0.0
7	47.96	0.00	0.00	0.00	0.00	0.00	0.00	0.0
8	47.70	0.00	0.00	0.00	0.00	0.00	0.00	0.0
		0.00	0.00	0.00	0.00	0.00	0.00	4407
9	47.50	0.00	3.60	1.21	12.39	11.62	11.62	4407
		0.00	3.60	1.16	13.13	13.13	13.13p	12739
10	47.00	4.90	8.20	2.64	29.89	29.89	34.79p	12739
11	46.50	9.81	12.79	4.13	46.64	46.64	56.45p	12739
12	46.00	14.71	17.39	5.61	63.40	51.06	65.78	12739
13	45.50	19.62	21.98	7.09	80.16	54.67	74.29	12739
14	45.00	24.52	26.58	8.57	96.92	58.69	83.22	12739
		Total>	51.10	13.50m	170.60	60.81	60.81	24224
15	44.50	Total>	61.10	16.00m	186.58	70.69	70.69	25435
16	44.17	Total>	67.61	17.63m	196.96	77.28	77.28	26222
17	43.85	Total>	74.11	19.25m	207.35	83.93	83.93	27010

(continued)

Stage No.4 Excavate to elevation 47.70 on RIGHT side

Node no.	Y coord	----- RIGHT side -----					Total earth pressure	Coeff. of subgrade reaction
		Water press. kN/m2	Vertic -al kN/m2	Effective Active limit kN/m2	Effective Passive limit kN/m2	Earth pressure kN/m2		
18	43.65	Total>	78.11	20.25m	213.74	88.05	88.05	27494
19	43.33	Total>	84.61	21.88m	224.12	94.75	94.75	28281
20	43.00	Total>	91.11	23.50m	234.51	101.44	101.44	29069
21	42.50	Total>	101.12	26.00m	250.49	111.69	111.69	30280
22	42.00	Total>	111.12	28.50m	266.47	121.87	121.87	31491
23	41.50	Total>	121.13	31.00m	282.45	131.99	131.99	32702
24	41.13	Total>	128.63	32.88m	294.44	139.55	139.55	33611
25	40.75	Total>	136.14	34.75m	306.42	147.09	147.09	34519

Note: 11.11a Soil pressure at active limit
 56.45p Soil pressure at passive limit

Units: kN,m

Stage No.4 Excav. to elev. 47.70 on RIGHT side

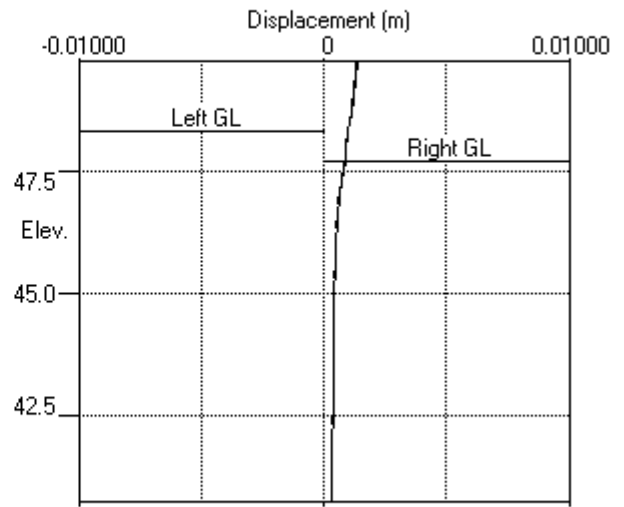
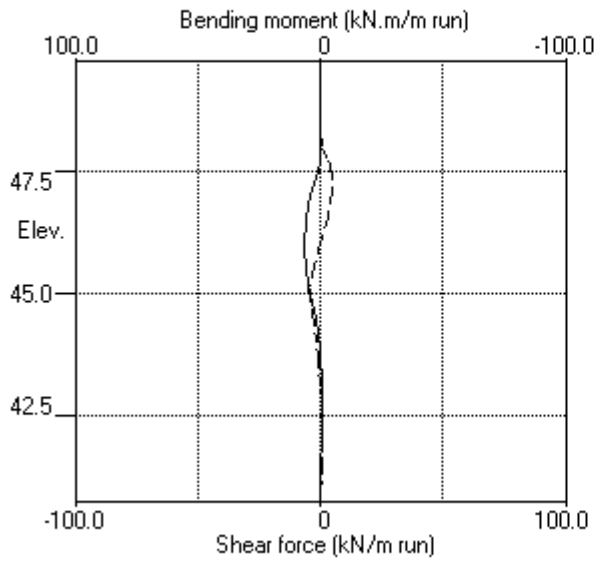

Stage No.4 Excav. to elev. 47.70 on RIGHT side

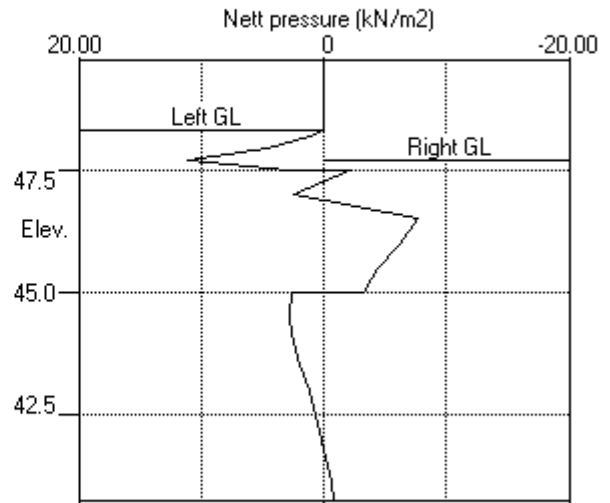
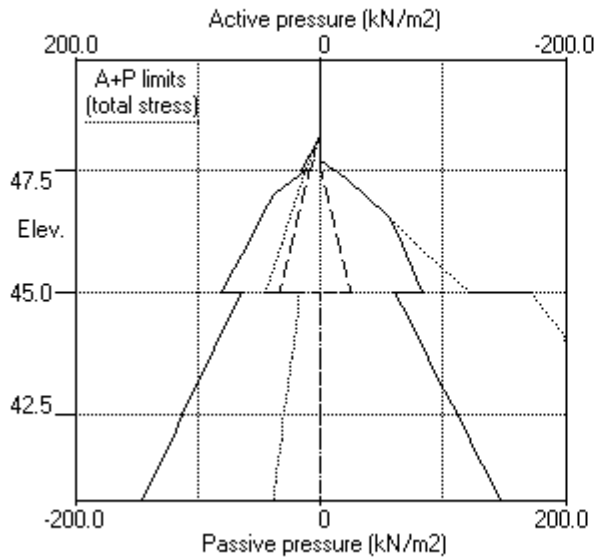

PILEDESIGNS LTD
 Program: WALLAP Version 6.06 Revision A51.B69.R54
 Licensed from GEOSOLVE
 Data filename/Run ID: Hampstead_Wall_4_450mm_rev_01_SLS
 Hampstead - 24-26 Redington Gardens
 Wall 4, Secant-SLS, 450 dia @ 650 - run 01

Sheet No.
 Job No. 21495
 Made by : DBS
 Date: 1-10-2018
 Checked :

Units: kN,m

Stage No. 7 Excavate to elevation 43.65 on RIGHT side

STABILITY ANALYSIS of Fully Embedded Wall according to Strength Factor method
 Factor of safety on soil strength

Stage No.	--- G.L. --- Act. Pass.	Strut Elev.	FoS for toe elev. =	Moment of equil. at elev.	Toe elev. for FoS =	Wall Penetr-ation	Direction of failure
7	48.30 43.65	48.21	40.75	n/a	1.500	0.74	L to R

BENDING MOMENT and DISPLACEMENT ANALYSIS of Fully Embedded Wall

Analysis options

Length of wall perpendicular to section = 50.00m
 Subgrade reaction model - Boussinesq Influence coefficients
 Soil deformations are elastic until the active or passive limit is reached
 Open Tension Crack analysis - No

Rigid boundaries: Left side 50.00 from wall
 Right side 50.00 from wall

Limit State: Serviceability Limit State

Calculated Bending Moments and Strut Forces are to be multiplied by a factor of 1.35 to obtain values for structural design. See summary for factored values.

Node no.	Y coord	Nett pressure kN/m ²	Wall disp. m	Wall rotation rad.	Shear force kN/m	Bending moment kN.m/m	Strut forces kN/m	EI of wall kN.m ² /m
1	49.75	0.00	-0.003	-2.44E-03	0.0	0.0		60696
2	49.38	0.00	-0.002	-2.44E-03	0.0	0.0		60696
3	49.00	0.00	-0.001	-2.44E-03	0.0	0.0		60696
4	48.65	0.00	-0.000	-2.44E-03	0.0	0.0		60696
5	48.30	0.00	0.001	-2.44E-03	0.0	0.0		60696
6	48.21	1.14	0.001	-2.44E-03	0.1	0.0	46.9	60696
		1.14	0.001	-2.44E-03	-46.8	0.0		
7	47.96	4.63	0.002	-2.41E-03	-46.1	-11.8		60696
8	47.70	8.36	0.002	-2.34E-03	-44.4	-23.4		60696
9	47.50	11.25	0.003	-2.25E-03	-42.5	-32.0		60696
		11.11	0.003	-2.25E-03	-42.5	-32.0		
10	47.00	18.11	0.004	-1.91E-03	-35.1	-50.7		60696
11	46.50	24.82	0.005	-1.43E-03	-24.4	-66.1		60696
12	46.00	31.38	0.005	-8.54E-04	-10.4	-74.4		60696
13	45.50	37.85	0.005	-2.37E-04	6.9	-75.5		60696
14	45.00	47.43	0.005	3.44E-04	28.3	-65.7		60696
		16.50	0.005	3.44E-04	28.3	-65.7		
15	44.50	19.00	0.005	8.18E-04	37.1	-49.4		60696
16	44.17	20.63	0.005	1.04E-03	43.6	-36.3		60696
17	43.85	26.62	0.004	1.19E-03	51.3	-20.0		60696
18	43.65	33.05	0.004	1.24E-03	57.2	-9.2		60696
		-71.23	0.004	1.24E-03	57.2	-9.2		
19	43.33	-59.61	0.004	1.25E-03	36.0	5.7		60696
20	43.00	-47.44	0.003	1.20E-03	18.6	14.2		60696
21	42.50	-29.20	0.003	1.07E-03	-0.6	17.5		60696
22	42.00	-12.02	0.002	9.44E-04	-10.9	13.6		60696
23	41.50	4.38	0.002	8.60E-04	-12.8	6.6		60696
24	41.13	16.75	0.002	8.33E-04	-8.8	2.1		60696
25	40.75	30.37	0.001	8.27E-04	0.0	-0.0		---
At elev. 48.21 Strut force =			46.9 kN/strut =		46.9 kN/m run			

(continued)

Stage No.7 Excavate to elevation 43.65 on RIGHT side

Node no.	Y coord	LEFT side					Total earth pressure kN/m2	Coeff. of subgrade reaction kN/m3
		Water press. kN/m2	Vertic -al kN/m2	Effective Active limit kN/m2	Effective Passive limit kN/m2	Earth pressure kN/m2		
1	49.75	0.00	0.00	0.00	0.00	0.00	0.00	0.0
2	49.38	0.00	0.00	0.00	0.00	0.00	0.00	0.0
3	49.00	0.00	0.00	0.00	0.00	0.00	0.00	0.0
4	48.65	0.00	0.00	0.00	0.00	0.00	0.00	0.0
5	48.30	0.00	0.00	0.00	0.00	0.00	0.00	0.0
		0.00	0.00	0.00	0.00	0.00	0.00	72533
6	48.21	0.88	0.76	0.26	2.62	0.26	1.14a	2242
7	47.96	3.38	3.69	1.24	12.71	1.24	4.63a	2242
8	47.70	5.89	7.35	2.48	25.31	2.48	8.36a	2242
9	47.50	7.85	10.12	3.41	34.83	3.41	11.25a	2242
		7.85	10.12	3.26	36.90	3.26	11.11a	6436
10	47.00	12.75	16.61	5.36	60.58	5.36	18.11a	6436
11	46.50	17.66	22.21	7.17	81.01	7.17	24.82a	6436
12	46.00	22.56	27.34	8.82	99.70	8.82	31.38a	6436
13	45.50	27.47	32.19	10.38	117.39	10.38	37.85a	6436
14	45.00	32.37	36.86	11.89	134.43	15.06	47.43	6436
		Total>	69.24	16.50m	188.73	16.50	16.50a	13073
15	44.50	Total>	79.20	19.00m	204.67	19.00	19.00a	13727
16	44.17	Total>	85.62	20.63m	214.98	20.63	20.63a	14152
17	43.85	Total>	92.03	22.25m	225.27	26.62	26.62	14577
18	43.65	Total>	95.96	23.25m	231.59	33.05	33.05	14838
19	43.33	Total>	102.33	24.87m	241.84	43.92	43.92	15263
20	43.00	Total>	108.69	26.50m	252.08	54.97	54.97	15688
21	42.50	Total>	118.45	29.00m	267.82	71.82	71.82	16341
22	42.00	Total>	128.21	31.50m	283.55	88.26	88.26	16995
23	41.50	Total>	137.95	34.00m	299.28	104.39	104.39	17649
24	41.13	Total>	145.27	35.87m	311.07	116.51	116.51	18139
25	40.75	Total>	152.58	37.75m	322.86	129.19	129.19	18629

Node no.	Y coord	RIGHT side					Total earth pressure kN/m2	Coeff. of subgrade reaction kN/m3
		Water press. kN/m2	Vertic -al kN/m2	Effective Active limit kN/m2	Effective Passive limit kN/m2	Earth pressure kN/m2		
1	49.75	0.00	0.00	0.00	0.00	0.00	0.00	0.0
2	49.38	0.00	0.00	0.00	0.00	0.00	0.00	0.0
3	49.00	0.00	0.00	0.00	0.00	0.00	0.00	0.0
4	48.65	0.00	0.00	0.00	0.00	0.00	0.00	0.0
5	48.30	0.00	0.00	0.00	0.00	0.00	0.00	0.0
6	48.21	0.00	0.00	0.00	0.00	0.00	0.00	0.0
7	47.96	0.00	0.00	0.00	0.00	0.00	0.00	0.0
8	47.70	0.00	0.00	0.00	0.00	0.00	0.00	0.0
9	47.50	0.00	0.00	0.00	0.00	0.00	0.00	0.0
10	47.00	0.00	0.00	0.00	0.00	0.00	0.00	0.0
11	46.50	0.00	0.00	0.00	0.00	0.00	0.00	0.0
12	46.00	0.00	0.00	0.00	0.00	0.00	0.00	0.0
13	45.50	0.00	0.00	0.00	0.00	0.00	0.00	0.0
14	45.00	0.00	0.00	0.00	0.00	0.00	0.00	0.0
15	44.50	0.00	0.00	0.00	0.00	0.00	0.00	0.0
16	44.17	0.00	0.00	0.00	0.00	0.00	0.00	0.0
17	43.85	0.00	0.00	0.00	0.00	0.00	0.00	0.0
18	43.65	0.00	0.00	0.00	0.00	0.00	0.00	0.0
		Total>	0.00	0.00	135.63	104.28	104.28	24530
19	43.33	Total>	6.50	1.63m	146.01	103.52	103.52	25233

(continued)

Stage No.7 Excavate to elevation 43.65 on RIGHT side

Node no.	Y coord	----- RIGHT side -----					Total earth pressure kN/m2	Coeff. of subgrade reaction kN/m3
		Water press. kN/m2	Vertical kN/m2	Effective Active limit kN/m2	Effective Passive limit kN/m2	Earth pressure kN/m2		
20	43.00	Total>	13.00	3.25m	156.40	102.40	25935	
21	42.50	Total>	23.00	5.75m	172.37	101.02	27016	
22	42.00	Total>	33.00	8.25m	188.35	100.27	28096	
23	41.50	Total>	43.00	10.75m	204.33	100.00	29177	
24	41.13	Total>	50.51	12.63m	216.31	99.75	29987	
25	40.75	Total>	58.01	14.50m	228.29	98.82	30798	

Note: 20.63a Soil pressure at active limit
 123.45p Soil pressure at passive limit

Units: kN,m

Stage No.7 Excav. to elev. 43.65 on RIGHT side

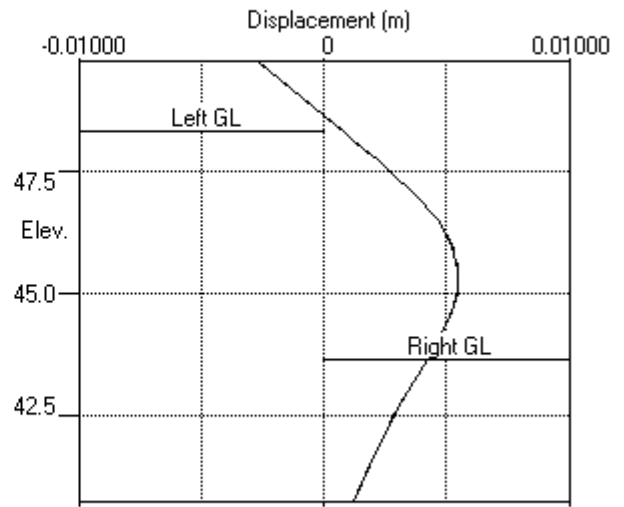
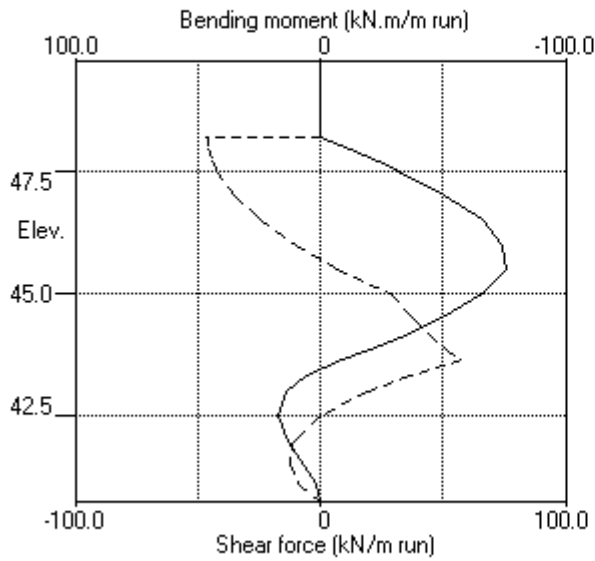

Stage No.7 Excav. to elev. 43.65 on RIGHT side

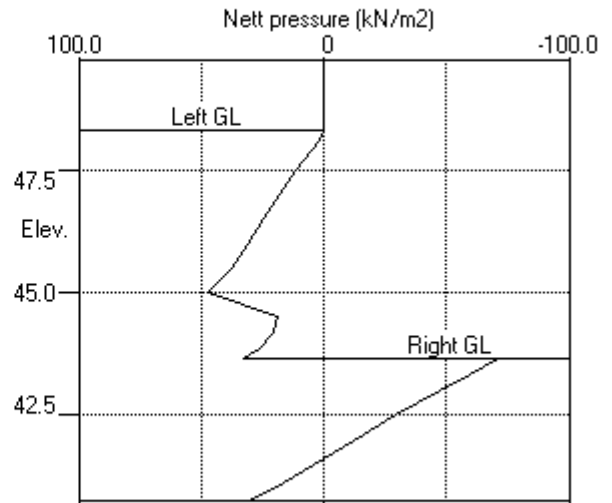
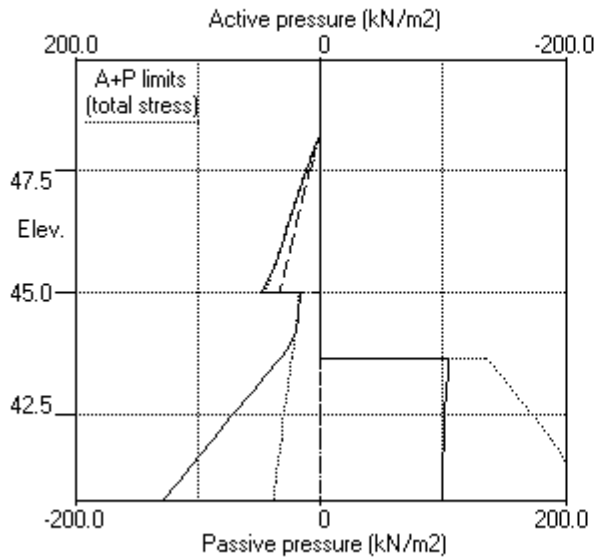

Units: kN,m

Stage No. 9 Change EI of wall to 43355 kN.m²/m run
Yield moment not defined
Allow wall to relax with new modulus value

STABILITY ANALYSIS of Fully Embedded Wall according to Strength Factor method
Factor of safety on soil strength

			FoS for toe elev. = 40.75	Toe elev. for FoS = 1.500			
Stage No.	--- G.L. Act.	--- Pass.	Strut Elev.	Factor of Safety	Moment of equil. at elev.	Toe Wall Penetr-ation elev. No FoS calc.	Direction of failure
9	48.30	43.65					

BENDING MOMENT and DISPLACEMENT ANALYSIS of Fully Embedded Wall

Analysis options

Length of wall perpendicular to section = 50.00m
Subgrade reaction model - Boussinesq Influence coefficients
Soil deformations are elastic until the active or passive limit is reached
Open Tension Crack analysis - No

Rigid boundaries: Left side 50.00 from wall
Right side 50.00 from wall

Limit State: Serviceability Limit State

Calculated Bending Moments and Strut Forces are to be multiplied by a factor of 1.35 to obtain values for structural design. See summary for factored values.

Node no.	Y coord	Nett pressure kN/m ²	Wall disp. m	Wall rotation rad.	Shear force kN/m	Bending moment kN.m/m	Strut forces kN/m	EI of wall kN.m ² /m
1	49.75	0.00	-0.003	-2.84E-03	0.0	0.0		43355
2	49.38	0.00	-0.002	-2.84E-03	0.0	0.0		43355
3	49.00	0.00	-0.001	-2.84E-03	0.0	0.0		43355
4	48.65	0.00	-0.000	-2.84E-03	0.0	0.0		43355
5	48.30	0.00	0.001	-2.84E-03	0.0	0.0		43355
6	48.21	1.33	0.001	-2.84E-03	0.1	0.0	43.2	43355
		1.33	0.001	-2.84E-03	-43.2	0.0		
7	47.96	4.63	0.002	-2.81E-03	-42.4	-11.1		43355
8	47.70	8.36	0.002	-2.71E-03	-40.8	-21.9		43355
9	47.50	11.25	0.003	-2.60E-03	-38.8	-30.0		43355
		11.11	0.003	-2.60E-03	-38.8	-30.0		
10	47.00	18.11	0.004	-2.16E-03	-31.5	-47.2		43355
11	46.50	24.82	0.005	-1.55E-03	-20.7	-61.2		43355
12	46.00	31.38	0.006	-8.26E-04	-6.7	-68.1		43355
13	45.50	37.85	0.006	-6.63E-05	10.6	-67.8		43355
14	45.00	44.26	0.006	6.23E-04	31.1	-56.6		43355
		16.50	0.006	6.23E-04	31.1	-56.6		
15	44.50	19.00	0.005	1.14E-03	40.0	-39.3		43355
16	44.17	20.63	0.005	1.36E-03	46.5	-25.5		43355
17	43.85	26.29	0.004	1.46E-03	54.1	-8.4	14.8	43355
		26.29	0.004	1.46E-03	39.3	-8.4		
18	43.65	33.79	0.004	1.47E-03	45.3	0.6		43355
		-69.75	0.004	1.47E-03	45.3	0.6		
19	43.33	-55.17	0.004	1.40E-03	25.0	12.4		43355
20	43.00	-41.10	0.003	1.27E-03	9.4	18.4		43355
21	42.50	-21.94	0.003	1.05E-03	-6.4	18.8		43355
22	42.00	-5.81	0.002	8.68E-04	-13.3	13.3		43355
23	41.50	8.30	0.002	7.58E-04	-12.7	6.0		43355

(continued)

Stage No.9 Change EI of wall to 43355 kN.m2/m run
Yield moment not defined
Allow wall to relax with new modulus value

Node no.	Y coord	RIGHT side						
		Water press. kN/m2	Vertic -al kN/m2	Effective Active limit kN/m2	Effective Passive limit kN/m2	Earth pressure kN/m2	Total earth pressure kN/m2	Coeff. of subgrade reaction kN/m3
11	46.50	0.00	0.00	0.00	0.00	0.00	0.00	0.0
12	46.00	0.00	0.00	0.00	0.00	0.00	0.00	0.0
13	45.50	0.00	0.00	0.00	0.00	0.00	0.00	0.0
14	45.00	0.00	0.00	0.00	0.00	0.00	0.00	0.0
15	44.50	0.00	0.00	0.00	0.00	0.00	0.00	0.0
16	44.17	0.00	0.00	0.00	0.00	0.00	0.00	0.0
17	43.85	0.00	0.00	0.00	0.00	0.00	0.00	0.0
18	43.65	0.00	0.00	0.00	0.00	0.00	0.00	0.0
		Total>	0.00	0.00	135.63	103.54	103.54	23272
19	43.33	Total>	6.50	1.63m	146.01	101.31	101.31	23938
20	43.00	Total>	13.00	3.25m	156.40	99.24	99.24	24605
21	42.50	Total>	23.00	5.75m	172.37	97.39	97.39	25630
22	42.00	Total>	33.00	8.25m	188.35	97.17	97.17	26655
23	41.50	Total>	43.00	10.75m	204.33	98.05	98.05	27680
24	41.13	Total>	50.51	12.63m	216.31	98.87	98.87	28449
25	40.75	Total>	58.01	14.50m	228.29	102.77	102.77	442653

Note: 20.63a Soil pressure at active limit
123.45p Soil pressure at passive limit

Units: kN,m

Stage No.9 Change EI of wall to 43355kN.m2/m run

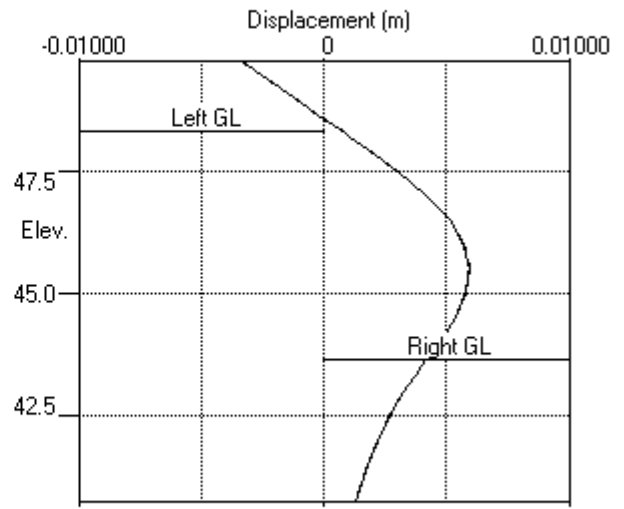
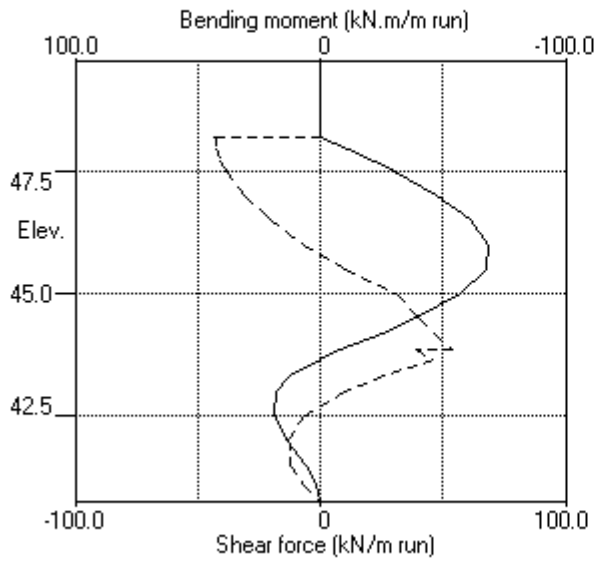

Stage No.9 Change EI of wall to 43355kN.m2/m run

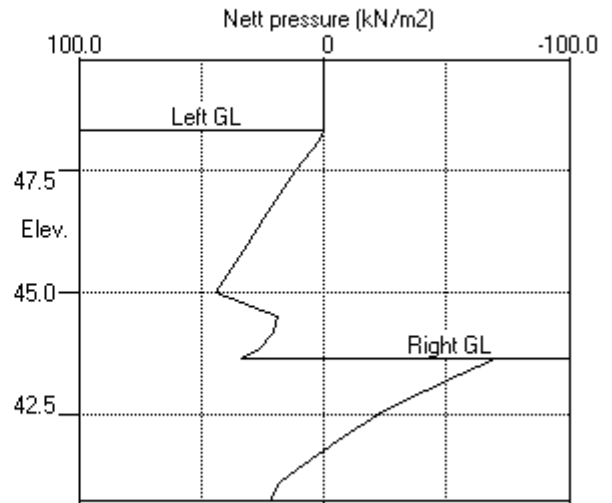
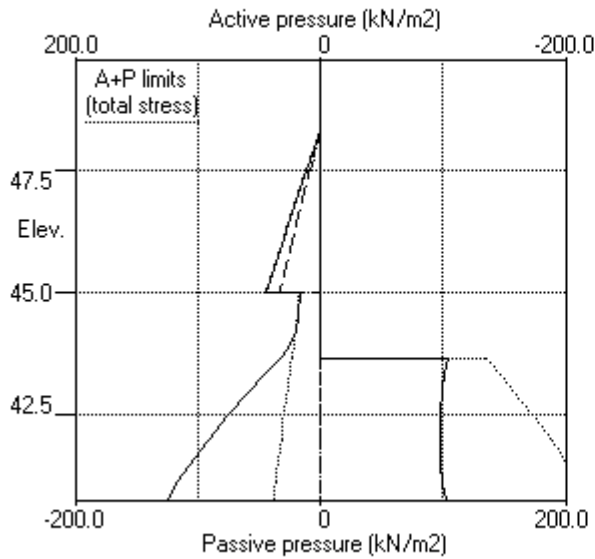

PILEDESIGNS LTD	Sheet No.
Program: WALLAP Version 6.06 Revision A51.B69.R54	Job No. 21495
Licensed from GEOSOLVE	Made by : DBS
Data filename/Run ID: Hampstead_Wall_4_450mm_rev_01_SLS	Date: 1-10-2018
Hampstead - 24-26 Redington Gardens	Checked :
Wall 4, Secant-SLS, 450 dia @ 650 - run 01	

Units: kN,m

Stage No. 10 Change properties of soil type 3 to soil type 4
Ko pressures will not be reset

STABILITY ANALYSIS of Fully Embedded Wall according to Strength Factor method
Factor of safety on soil strength

			FoS for toe	Toe elev. for		
			elev. = 40.75	FoS = 1.500		
Stage	--- G.L. ---	Strut	Factor	Moment	Toe	Wall
No.	Act. Pass.	Elev.	of	equilib.	elev.	Penetr
			Safety	at elev.		-ation
			More than one strut.	No FoS calc.		Direction
						of
						failure

BENDING MOMENT and DISPLACEMENT ANALYSIS of Fully Embedded Wall

Analysis options

Length of wall perpendicular to section = 50.00m
Subgrade reaction model - Boussinesq Influence coefficients
Soil deformations are elastic until the active or passive limit is reached
Open Tension Crack analysis - No

Rigid boundaries: Left side 50.00 from wall
Right side 50.00 from wall

Limit State: Serviceability Limit State

Calculated Bending Moments and Strut Forces are to be multiplied by a factor of 1.35 to obtain values for structural design. See summary for factored values.

Node no.	Y coord	Nett pressure kN/m2	Wall disp. m	Wall rotation rad.	Shear force kN/m	Bending moment kN.m/m	Strut forces kN/m	EI of wall kN.m2/m
1	49.75	0.00	-0.003	-2.77E-03	0.0	0.0		43355
2	49.38	0.00	-0.002	-2.77E-03	0.0	0.0		43355
3	49.00	0.00	-0.001	-2.77E-03	0.0	0.0		43355
4	48.65	0.00	-0.000	-2.77E-03	0.0	0.0		43355
5	48.30	0.00	0.001	-2.77E-03	0.0	0.0		43355
6	48.21	1.33	0.001	-2.77E-03	0.1	0.0	42.4	43355
		1.33	0.001	-2.77E-03	-42.3	0.0		
7	47.96	4.69	0.002	-2.74E-03	-41.5	-10.9		43355
8	47.70	8.48	0.002	-2.64E-03	-39.9	-21.5		43355
9	47.50	11.41	0.003	-2.53E-03	-37.9	-29.4		43355
		11.56	0.003	-2.53E-03	-37.9	-29.4		
10	47.00	18.84	0.004	-2.10E-03	-30.3	-46.1		43355
11	46.50	25.77	0.005	-1.51E-03	-19.1	-59.4		43355
12	46.00	32.46	0.006	-8.13E-04	-4.6	-65.4		43355
13	45.50	38.91	0.006	-9.13E-05	13.3	-63.8		43355
14	45.00	45.09	0.006	5.44E-04	34.3	-51.2		43355
		45.32	0.006	5.44E-04	34.3	-51.2		
15	44.50	52.00	0.005	9.72E-04	58.6	-28.5		43355
16	44.17	56.33	0.005	1.08E-03	76.2	-6.9		43355
17	43.85	60.65	0.005	1.00E-03	95.2	21.7	147.9	43355
		60.65	0.005	1.00E-03	-52.7	21.7		
18	43.65	63.30	0.004	9.08E-04	-40.3	13.0		43355
19	43.33	46.46	0.004	8.29E-04	-22.4	3.5		43355
20	43.00	29.62	0.004	8.08E-04	-10.1	-1.2		43355
21	42.50	14.75	0.003	8.23E-04	1.0	-3.1		43355
22	42.00	-0.12	0.003	8.49E-04	4.7	-1.6		43355
23	41.50	-10.69	0.003	8.58E-04	2.0	0.2		43355
24	41.13	-1.51	0.002	8.57E-04	-0.3	0.4		43355
25	40.75	3.20	0.002	8.56E-04	-0.0	-0.0		---

At elev. 48.21 Strut force = 42.4 kN/strut = 42.4 kN/m run
At elev. 43.85 Strut force = 147.9 kN/strut = 147.9 kN/m run

(continued)

Stage No.10 Change properties of soil type 3 to soil type 4
 Ko pressures will not be reset

Node no.	Y coord	----- RIGHT side -----					Total earth pressure	Coeff. of subgrade reaction
		Water press.	Vertical	Effective Active limit	Effective Passive limit	Earth pressure		
		kN/m2	kN/m2	kN/m2	kN/m2	kN/m2	kN/m2	kN/m3
19	43.33	0.00	6.50	2.28	21.14	21.14	21.14p	10666
20	43.00	0.00	13.00	4.57	42.29	42.29	42.29p	10963
21	42.50	4.90	18.10	6.36	58.86	58.86	63.77p	11419
22	42.00	9.81	23.19	8.15	75.44	75.44	85.25p	11876
23	41.50	14.71	28.29	9.94	92.02	92.02	106.73p	12333
24	41.13	18.39	32.11	11.28	104.45	90.49	108.89	12676
25	40.75	22.07	35.94	12.62	116.89	90.33	112.40	13018

Note: 85.13a Soil pressure at active limit
 106.73p Soil pressure at passive limit

Units: kN,m

Stage No.10 Change soil type 3 to soil type 4

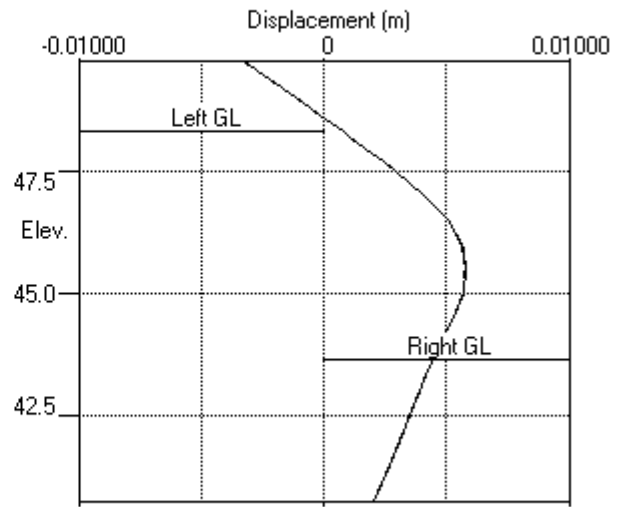
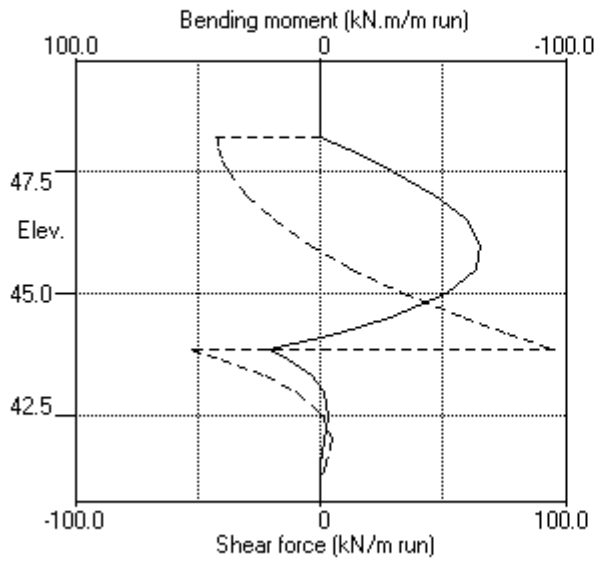

Stage No.10 Change soil type 3 to soil type 4

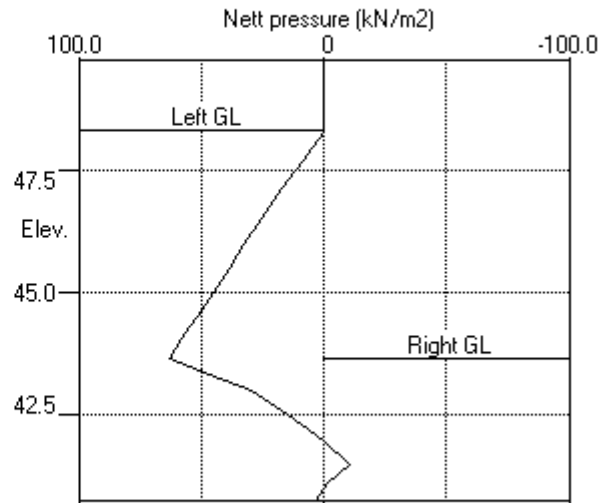
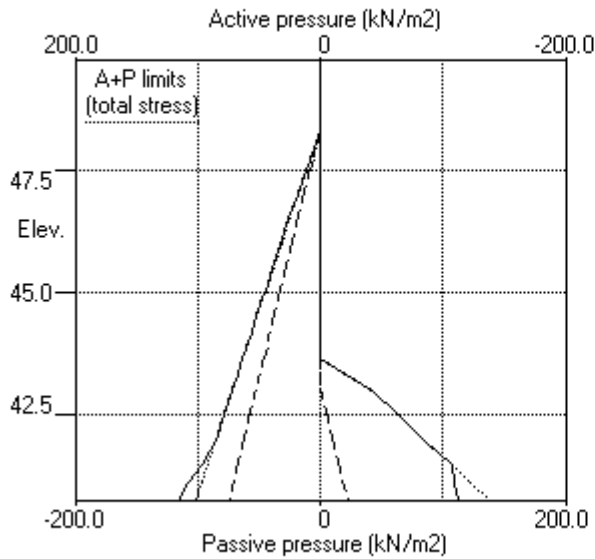

PILEDESIGNS LTD
 Program: WALLAP Version 6.06 Revision A51.B69.R54
 Licensed from GEOSOLVE
 Data filename/Run ID: Hampstead_Wall_4_450mm_rev_01_SLS
 Hampstead - 24-26 Redington Gardens
 Wall 4, Secant-SLS, 450 dia @ 650 - run 01

Sheet No.
 Job No. 21495
 Made by : DBS
 Date: 1-10-2018
 Checked :

 Units: kN,m

Summary of results

LIMIT STATE PARAMETERS

Limit State: Serviceability Limit State
 All loads and soil strengths are unfactored

STABILITY ANALYSIS of Fully Embedded Wall according to Strength Factor method
 Factor of safety on soil strength

Stage No.	G.L.		Strut Elev.	FoS for toe elev. = 40.75		Toe elev. for FoS = 1.500		Direction of failure
	Act.	Pass.		Factor of Safety	Moment at elev.	Toe elev.	Wall Penetration	
1	49.75	48.30	Cant.	3.598	41.81	44.66	3.64	R to L
2	49.75	48.30	Cant.	4.456	41.88	45.46	2.84	R to L
3	49.75	48.30	Cant.	4.682	41.85	45.71	2.59	R to L
4	48.30	47.70	Cant.	6.146	41.68	45.59	2.11	L to R
5	48.30	47.70		No analysis at this stage				
6	48.30	47.70	48.21	15.000	n/a	47.03	0.67	L to R
7	48.30	43.65	48.21	2.689	n/a	42.91	0.74	L to R
8	48.30	43.65		No analysis at this stage				

All remaining stages have more than one strut - FoS calculation n/a

PILEDESIGNS LTD
 Program: WALLAP Version 6.06 Revision A51.B69.R54
 Licensed from GEOSOLVE
 Data filename/Run ID: Hampstead_Wall_4_450mm_rev_01_SLS
 Hampstead - 24-26 Redington Gardens
 Wall 4, Secant-SLS, 450 dia @ 650 - run 01

Sheet No.
 Job No. 21495
 Made by : DBS
 Date: 1-10-2018
 Checked :

Units: kN,m

Summary of results

BENDING MOMENT and DISPLACEMENT ANALYSIS of Fully Embedded Wall

Analysis options

Length of wall perpendicular to section = 50.00m
 Subgrade reaction model - Boussinesq Influence coefficients
 Soil deformations are elastic until the active or passive limit is reached
 Open Tension Crack analysis - No

Rigid boundaries: Left side 50.00 from wall
 Right side 50.00 from wall

Limit State: Serviceability Limit State

Calculated Bending Moments and Strut Forces have been multiplied by a factor of 1.35 to obtain values for structural design.

Bending moment, shear force and displacement envelopes

Node no.	Y coord	Displacement		Bending moment				Shear force			
		max.	min.	Calculated		Factored		Calculated		Factored	
		m	m	max.	min.	max.	min.	max.	min.	max.	min.
				kN.m/m		kN.m/m		kN/m		kN/m	
1	49.75	0.001	-0.004	0	-0	0	-0	0	0	0	0
2	49.38	0.001	-0.002	0	-0	0	-0	0	-0	0	-1
3	49.00	0.001	-0.002	0	-0	0	-1	0	-2	0	-3
4	48.65	0.001	-0.002	0	-1	0	-2	0	-4	0	-5
5	48.30	0.001	-0.001	0	-3	0	-5	0	-7	0	-9
6	48.21	0.001	-0.001	0	-4	0	-5	0	-47	0	-63
7	47.96	0.002	-0.001	0	-12	0	-16	1	-46	1	-62
8	47.70	0.002	-0.001	1	-23	1	-32	3	-44	4	-60
9	47.50	0.003	-0.001	1	-32	2	-43	4	-42	6	-57
10	47.00	0.004	-0.001	4	-51	6	-68	4	-35	6	-47
11	46.50	0.005	-0.001	6	-66	8	-89	3	-24	4	-33
12	46.00	0.006	-0.001	7	-74	9	-100	4	-10	6	-14
13	45.50	0.006	-0.000	6	-75	8	-102	13	-3	18	-4
14	45.00	0.006	-0.000	4	-66	5	-89	34	-5	46	-7
15	44.50	0.005	-0.000	2	-49	2	-67	59	-4	79	-5
16	44.17	0.005	-0.000	1	-36	2	-49	76	-3	103	-4
17	43.85	0.005	-0.000	22	-20	29	-27	95	-53	129	-71
18	43.65	0.004	-0.000	13	-9	17	-12	57	-40	77	-54
19	43.33	0.004	-0.000	12	-1	17	-1	36	-22	49	-30
20	43.00	0.004	-0.000	18	-1	25	-2	19	-10	25	-14
21	42.50	0.003	-0.000	19	-3	25	-4	1	-6	1	-9
22	42.00	0.003	-0.000	14	-2	18	-2	5	-13	6	-18
23	41.50	0.003	-0.000	7	-0	9	-0	2	-13	3	-17
24	41.13	0.002	-0.000	2	-0	3	-0	0	-9	0	-12
25	40.75	0.002	-0.000	0	-0	0	-0	0	-0	0	-0

Summary of results (continued)

Calculated Bending Moments and Strut Forces have been multiplied by a factor of 1.35 to obtain values for structural design.

Maximum and minimum bending moment and shear force at each stage

Stage no.	Bending moment						Shear force					
	Calculated		Factored		Calculated		Factored					
min.	max. elev.	min. elev.	max. elev.	max. elev.	min. elev.	max. elev.	min. elev.	max. elev.	min. elev.	max. elev.	max.	
	kN.m/m	kN.m/m		kN.m/m		kN/m		kN/m		kN/m		
1	43.00	-14	46.50	1	-19	8	45.00	-8	47.50	11		
-11	2	42.50	-14	46.50	1	-19	7	45.00	-8	47.70	10	
-11	3	42.50	-14	46.50	1	-18	7	45.00	-8	47.96	10	
-11	4	46.00	-1	43.00	9	-1	4	47.00	-5	45.00	6	
-7	5	No calculation at this stage										
	6	43.65	-2	45.50	2	-2	4	45.00	-4	48.21	6	
-6	7	18	42.50	-75	45.50	24	-102	57	43.65	-47	48.21	77
-63	8	No calculation at this stage										
	9	19	42.50	-68	46.00	25	-92	54	43.85	-43	48.21	73
-58	10	22	43.85	-65	46.00	29	-88	95	43.85	-53	43.85	129
-71	11	No calculation at this stage										
	12	8	43.85	-71	45.50	11	-96	91	43.85	-44	48.21	123
-60												

Maximum and minimum displacement at each stage

Stage no.	Displacement				Stage description
	maximum	elev.	minimum	elev.	
	m		m		
1	0.000	49.75	-0.002	49.75	Excav. to elev. 48.30 on LEFT side
2	0.000	49.75	-0.002	49.75	Apply surcharge no.1 at elev. 48.30
3	0.000	49.75	-0.002	49.75	Apply water pressure profile no.1
4	0.001	49.75	0.000	49.75	Excav. to elev. 47.70 on RIGHT side
5	No calculation at this stage				Install strut no.1 at elev. 48.21
6	0.001	49.75	0.000	49.75	Apply water pressure profile no.2
7	0.005	45.50	-0.003	49.75	Excav. to elev. 43.65 on RIGHT side
8	No calculation at this stage				Install strut no.2 at elev. 43.85
9	0.006	45.50	-0.003	49.75	Change EI of wall to 43355kN.m ² /m run
10	0.006	45.50	-0.003	49.75	Change soil type 3 to soil type 4
11	No calculation at this stage				Apply surcharge no.2 at elev. 43.65
12	0.006	45.50	-0.004	49.75	Apply water pressure profile no.3

Strut forces at each stage (horizontal components)

Stage no.	Strut no. 1			Strut no. 2		
	at elev. 48.21			at elev. 43.85		
	Calculated	Factored	Calculated	Factored	Calculated	Factored
	kN per m run	kN per strut	kN per strut	kN per m run	kN per strut	kN per strut
6	4	4	6	---	---	---
7	47	47	63	---	---	---
9	43	43	58	15	15	20
10	42	42	57	148	148	200
12	44	44	60	116	116	156

Units: kN,m

Bending moment, shear force, displacement envelopes

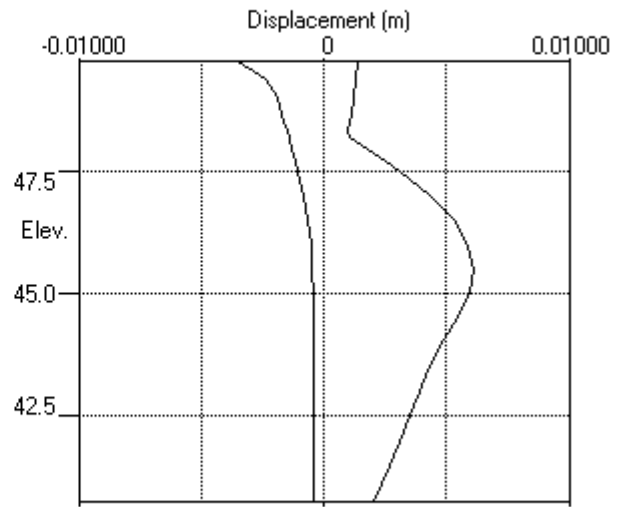
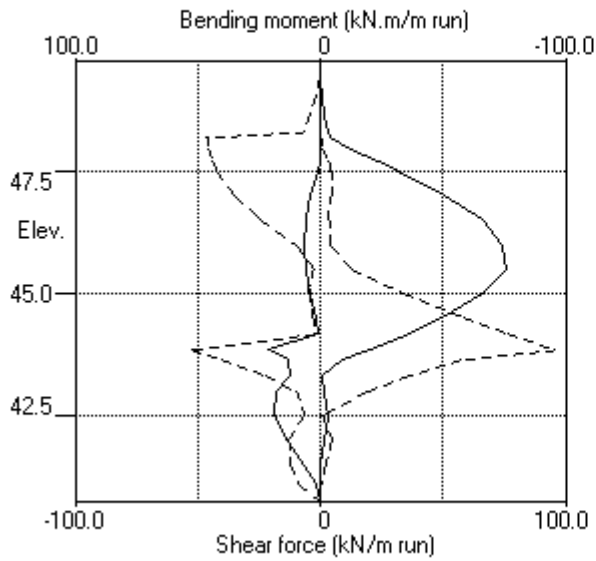



WALLAP

5-ULS1

PILEDESIGNS LTD
 Program: WALLAP Version 6.06 Revision A51.B69.R54
 Licensed from GEOSOLVE
 Data filename/Run ID: Hampstead_Wall_5_450mm_rev_01_ULS1
 Hampstead - 24-26 Redington Gardens
 Wall 5, Secant-ULS1, 450 dia @ 650 - run 01

Sheet No.
 Job No. 21495
 Made by : DBS
 Date: 1-10-2018
 Checked :

Units: kN,m

INPUT DATA

SOIL PROFILE

Stratum no.	Elevation of top of stratum	Soil types	
		Left side	Right side
1	49.75	1 Made Ground dr	1 Made Ground dr
2	47.50	2 Claygate Clay dr	2 Claygate Clay dr
3	45.00	3 London Clay und	3 London Clay und

SOIL PROPERTIES (Unfactored SLS soil strengths)

-- Soil type --	Bulk density	Young's Modulus	At rest coeff.	Consol state.	Active limit	Passive limit	Cohesion
No. Description (Datum elev.)	kN/m3	Eh,kN/m2 (dEh/dy)	Ko (dKo/dy)	NC/OC (Nu)	Ka (Kac)	Kp (Kpc)	kN/m2 (dc/dy)
1 Made Ground dr	18.00	10000	0.530	OC (0.250)	0.337 (0.000)	3.442 (0.000)	
2 Claygate Clay dr	19.00	30000	1.000	NC (0.200)	0.323 (1.330)	3.647 (5.195)	0.0d
3 London Cl.. (45.00)	20.00	40000 (4000)	1.000	OC (0.490)	1.000 (2.476)	1.000 (2.390)	50.00u (5.000)
4 London Cl.. (45.00)	20.00	30800 (3080)	1.000	OC (0.200)	0.351 (1.391)	3.253 (4.831)	0.0d

Additional soil parameters associated with Ka and Kp

No. Description	--- parameters for Ka ---			--- parameters for Kp ---		
	Soil friction angle	Wall adhesion coeff.	Back-fill angle	Soil friction angle	Wall adhesion coeff.	Back-fill angle
1 Made Ground dr	26.00	0.670	0.00	26.00	0.500	0.00
2 Claygate Clay dr	27.00	0.670	0.00	27.00	0.500	0.00
3 London Clay und	0.00	0.670	0.00	0.00	0.500	0.00
4 London Clay dr	25.00	0.670	0.00	25.00	0.500	0.00

GROUND WATER CONDITIONS

Density of water = 9.810 kN/m3

	Left side	Right side
Initial water table elevation	49.40	49.40

Automatic water pressure balancing at toe of wall : No

Water profile no.	Left side				Right side			
	Point no.	Elev. m	Piezo elev. m	Water press. kN/m2	Point no.	Elev. m	Piezo elev. m	Water press. kN/m2
1	1	49.40	49.40	0.0	1	47.50	47.50	0.0 MC+WC
2	1	49.40	49.40	0.0	1	43.00	43.00	0.0 MC+WC
3	1	49.40	49.40	0.0	1	43.65	43.65	0.0 MC+WC
					2	43.65	49.40	56.4

WALL PROPERTIES

Type of structure = Fully Embedded Wall
 Elevation of toe of wall = 40.75
 Maximum finite element length = 0.50 m
 Youngs modulus of wall E = 1.9600E+07 kN/m2
 Moment of inertia of wall I = 3.0968E-03 m4/m run
 E.I = 60696 kN.m2/m run
 Yield Moment of wall = Not defined

STRUTS and ANCHORS

Strut/ anchor no.	Elev.	Strut spacing m	X-section area of strut sq.m	Youngs modulus kN/m ²	Free length m	Inclin -ation (degs)	Pre- stress /strut kN	Tension allowed
1	48.10	1.00	0.400000	1.400E+07	5.00	0.00	0	No
2	43.85	1.00	0.300000	1.400E+07	5.00	0.00	0	No

SURCHARGE LOADS

Surch -arge no.	Elev.	Distance from wall	Length parallel to wall	Width perpend. to wall	Surcharge ----- kN/m ² ----- Near edge Far edge		Equiv. soil type	Partial factor/ Category
1	49.75	0.50(L)	10.00	10.00	10.00	=	N/A	1.10 Var
2	43.65	-0.00(R)	10.00	10.00	57.00	=	N/A	1.00 P/F

Note: L = Left side, R = Right side

Limit State Categories P/U = Permanent Unfavourable
P/F = Permanent Favourable
Var = Variable (unfavourable)

CONSTRUCTION STAGES

Construction stage no.	Stage description
1	Apply surcharge no.1 at elevation 49.75
2	Apply water pressure profile no.1 (Mod. Conserv.)
3	Excavate to elevation 47.80 on RIGHT side
4	Install strut or anchor no.1 at elevation 48.10
5	Apply water pressure profile no.2 (Mod. Conserv.)
6	Excavate to elevation 43.20 on RIGHT side
7	Fill to elevation 43.65 on RIGHT side with soil type 1
8	Install strut or anchor no.2 at elevation 43.85
9	Change EI of wall to 43355 kN.m ² /m run Yield moment not defined Allow wall to relax with new modulus value
10	Change properties of soil type 3 to soil type 4 Ko pressures will not be reset
11	Apply surcharge no.2 at elevation 43.65 No analysis at this stage
12	Apply water pressure profile no.3 (Mod. Conserv.)

FACTORS OF SAFETY and ANALYSIS OPTIONS

Limit State options: ULS DAL Combination 1
Water pressures : Moderately Conservative
Partial factor on C' = 1.000
Partial factor on Phi' = 1.000
Partial factor on Cu = 1.000
Partial factor on Soil Modulus = 1.000
Partial factor on Permanent Unfavourable loads = 1.000
Partial factor on Permanent Favourable loads = 1.000
Partial factor on Variable Unfavourable loads = 1.100
Design factor on calculated Bending Moments = 1.350

Parameters for undrained strata:

Minimum equivalent fluid density = 5.00 kN/m³
Maximum depth of water filled tension crack = 0.00 m

Bending moment and displacement calculation:

Method - Subgrade reaction model using Influence Coefficients
Open Tension Crack analysis? - No
Non-linear Modulus Parameter (L) = 9.000 m

Boundary conditions:

Length of wall (normal to plane of analysis) = 50.00 m

Width of excavation on Left side of wall = 50.00 m
Width of excavation on Right side of wall = 50.00 m

Distance to rigid boundary on Left side = 50.00 m
Distance to rigid boundary on Right side = 50.00 m

OUTPUT OPTIONS

Stage no.	Stage description	Output options		
		Displacement	Active, Graph.	Passive output
		Bending mom.	pressures	
		Shear force		
1	Apply surcharge no.1 at elev. 49.75	No	No	No
2	Apply water pressure profile no.1	Yes	Yes	Yes
3	Excav. to elev. 47.80 on RIGHT side	Yes	Yes	Yes
4	Install strut no.1 at elev. 48.10	Yes	Yes	Yes
5	Apply water pressure profile no.2	Yes	Yes	Yes
6	Excav. to elev. 43.20 on RIGHT side	Yes	Yes	Yes
7	Fill to elev. 43.65 on RIGHT side	Yes	Yes	Yes
8	Install strut no.2 at elev. 43.85	Yes	Yes	Yes
9	Change EI of wall to 43355kN.m ² /m run	No	No	No
10	Change soil type 3 to soil type 4	No	No	No
11	Apply surcharge no.2 at elev. 43.65	No	No	No
12	Apply water pressure profile no.3	No	No	No
*	Summary output	Yes	-	Yes

Program WALLAP - Copyright (C) 2017 by DL Borin, distributed by GEOSOLVE
 150 St. Alphonsus Road, London SW4 7BW, UK www.geosolve.co.uk

Units: kN,m

Stage No.12 Apply water pressure profile no.3 (Mod. Conserv.)

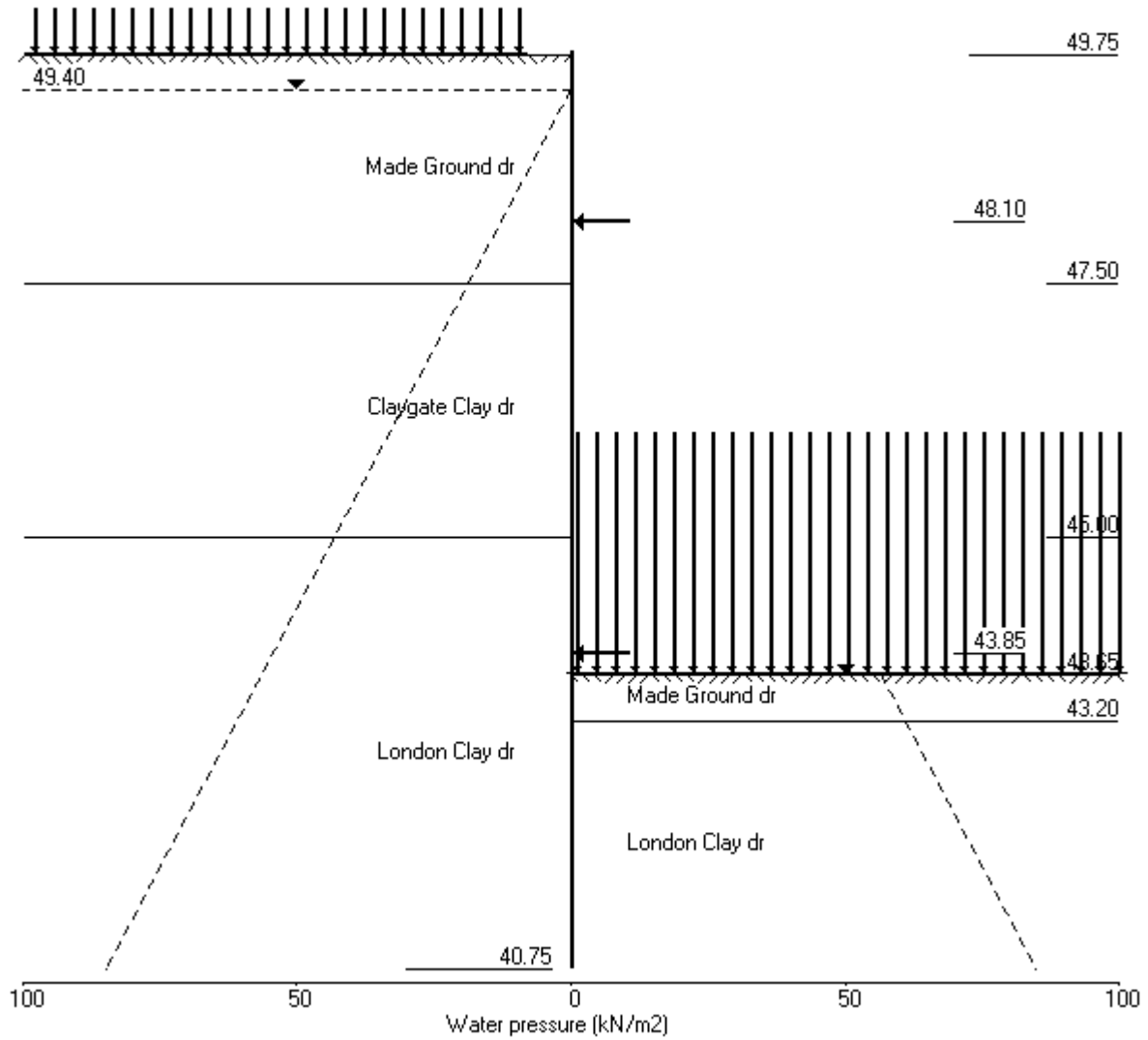

PILEDESIGNS LTD
 Program: WALLAP Version 6.06 Revision A51.B69.R54
 Licensed from GEOSOLVE
 Data filename/Run ID: Hampstead_Wall_5_450mm_rev_01_ULS1
 Hampstead - 24-26 Redington Gardens
 Wall 5, Secant-ULS1, 450 dia @ 650 - run 01

Sheet No.
 Job No. 21495
 Made by : DBS
 Date: 1-10-2018
 Checked :

Units: kN,m

Stage No. 3 Excavate to elevation 47.80 on RIGHT side

BENDING MOMENT and DISPLACEMENT ANALYSIS of Fully Embedded Wall

Analysis options

Length of wall perpendicular to section = 50.00m
 Subgrade reaction model - Boussinesq Influence coefficients
 Soil deformations are elastic until the active or passive limit is reached
 Open Tension Crack analysis - No

Rigid boundaries: Left side 50.00 from wall
 Right side 50.00 from wall

Limit State: ULS DA1 Combination 1

Calculated Bending Moments and Strut Forces are to be multiplied by a factor of 1.35 to obtain values for structural design. See summary for factored values.

Node no.	Y coord	Nett pressure kN/m2	Wall disp. m	Wall rotation rad.	Shear force kN/m	Bending moment kN.m/m	Strut forces kN/m	EI of wall kN.m2/m
1	49.75	0.00	0.014	3.10E-03	0.0	0.0		60696
2	49.40	2.45	0.012	3.10E-03	0.4	0.2		60696
3	49.08	7.27	0.011	3.10E-03	2.0	0.5		60696
4	48.75	11.95	0.010	3.09E-03	5.1	1.6		60696
5	48.42	16.42	0.009	3.08E-03	9.7	4.0		60696
6	48.10	20.77	0.008	3.04E-03	15.8	8.1		60696
7	47.80	24.70	0.008	2.99E-03	22.6	13.9		60696
8	47.50	9.99	0.007	2.90E-03	27.8	21.5		60696
		8.47	0.007	2.90E-03	27.8	21.5		
9	47.00	-6.71	0.005	2.67E-03	28.2	35.8		60696
10	46.50	-21.95	0.004	2.32E-03	21.1	48.3		60696
11	46.00	-35.21	0.003	1.89E-03	6.8	56.5		60696
12	45.50	-24.77	0.002	1.42E-03	-8.2	56.4		60696
13	45.00	-11.64	0.002	9.93E-04	-17.3	49.2		60696
		-17.49	0.002	9.93E-04	-17.3	49.2		
14	44.50	-2.85	0.001	6.33E-04	-22.4	38.3		60696
15	44.17	3.31	0.001	4.48E-04	-22.3	30.9		60696
16	43.85	7.26	0.001	3.01E-04	-20.6	23.8		60696
17	43.65	8.78	0.001	2.29E-04	-19.0	19.8		60696
18	43.20	10.20	0.001	1.11E-04	-14.7	12.2		60696
19	43.00	10.16	0.001	7.57E-05	-12.7	9.4		60696
20	42.50	8.87	0.001	1.91E-05	-7.9	4.3		60696
21	42.00	6.62	0.001	-4.63E-06	-4.1	1.5		60696
22	41.50	3.97	0.001	-1.16E-05	-1.4	0.2		60696
23	41.13	1.89	0.001	-1.23E-05	-0.3	-0.0		60696
24	40.75	-0.23	0.001	-1.23E-05	0.0	-0.0		---

Node no.	Y coord	LEFT side					Total earth pressure kN/m2	Coeff. of subgrade reaction kN/m3
		Water press. kN/m2	Vertical	Active limit	Passive limit	Earth pressure kN/m2		
1	49.75	0.00	0.00	0.00	0.00	0.00	0.00	3524
2	49.40	0.00	7.29	2.45	25.08	2.45	2.45a	3524
3	49.08	3.19	12.14	4.09	41.78	4.09	7.27a	3524
4	48.75	6.38	16.54	5.57	56.94	5.57	11.95a	3524
5	48.42	9.56	20.37	6.86	70.12	6.86	16.42a	3524
6	48.10	12.75	23.80	8.01	81.93	8.01	20.77a	3524
7	47.80	15.70	26.74	9.00	92.04	9.00	24.70a	3524
8	47.50	18.64	29.52	9.94	101.62	9.94	28.58a	3524
		18.64	29.52	9.52	107.66	9.52	28.16a	10171

(continued)

Stage No.3 Excavate to elevation 47.80 on RIGHT side

Node no.	Y coord	LEFT side					Total earth pressure	Coeff. of subgrade reaction
		Water press.	Vertic -al	Effective Active limit	Effective Passive limit	Earth pressure		
		kN/m2	kN/m2	kN/m2	kN/m2	kN/m2	kN/m2	kN/m3
9	47.00	23.54	34.42	11.10	125.52	11.10	34.65a	10171
10	46.50	28.45	39.12	12.62	142.65	12.62	41.07a	10171
11	46.00	33.35	43.68	14.09	159.28	16.12	49.48	10171
12	45.50	38.26	48.14	15.53	175.57	28.80	67.06	10171
13	45.00	43.16	52.55	16.95	191.63	39.07	82.24	10171
		Total>	95.71	23.75m	215.22	69.02	69.02	19645
14	44.50	Total>	105.48	26.25m	230.96	85.30	85.30	20627
15	44.17	Total>	111.81	27.88m	241.18	94.43	94.43	21266
16	43.85	Total>	118.14	29.50m	251.39	102.60	102.60	21904
17	43.65	Total>	122.03	30.50m	257.67	107.23	107.23	22297
18	43.20	Total>	130.77	32.75m	271.80	116.78	116.78	23181
19	43.00	Total>	134.66	33.75m	278.07	120.73	120.73	23574
20	42.50	Total>	144.37	36.25m	293.76	130.09	130.09	24556
21	42.00	Total>	154.09	38.75m	309.46	139.02	139.02	25538
22	41.50	Total>	163.82	41.25m	325.16	147.78	147.78	26520
23	41.13	Total>	171.12	43.13m	336.94	154.31	154.31	27257
24	40.75	Total>	176.43	45.00m	346.74	160.83	160.83	27994

Node no.	Y coord	RIGHT side					Total earth pressure	Coeff. of subgrade reaction
		Water press.	Vertic -al	Effective Active limit	Effective Passive limit	Earth pressure		
		kN/m2	kN/m2	kN/m2	kN/m2	kN/m2	kN/m2	kN/m3
1	49.75	0.00	0.00	0.00	0.00	0.00	0.00	0.0
2	49.40	0.00	0.00	0.00	0.00	0.00	0.00	0.0
3	49.08	0.00	0.00	0.00	0.00	0.00	0.00	0.0
4	48.75	0.00	0.00	0.00	0.00	0.00	0.00	0.0
5	48.42	0.00	0.00	0.00	0.00	0.00	0.00	0.0
6	48.10	0.00	0.00	0.00	0.00	0.00	0.00	0.0
7	47.80	0.00	0.00	0.00	0.00	0.00	0.00	0.0
		0.00	0.00	0.00	0.00	0.00	0.00	4799
8	47.50	0.00	5.40	1.82	18.59	18.59	18.59p	4799
		0.00	5.40	1.74	19.69	19.69	19.69p	13879
9	47.00	4.90	10.00	3.22	36.45	36.45	41.36p	13879
10	46.50	9.81	14.59	4.71	53.21	53.21	63.02p	13879
11	46.00	14.71	19.19	6.19	69.97	69.97	84.68p	13879
12	45.50	19.62	23.78	7.67	86.73	72.21	91.83	13879
13	45.00	24.52	28.38	9.15	103.49	69.35	93.88	13879
		Total>	52.90	14.00m	172.41	86.51	86.51	26259
14	44.50	Total>	62.90	16.50m	188.38	88.15	88.15	27572
15	44.17	Total>	69.41	18.13m	198.77	91.12	91.12	28425
16	43.85	Total>	75.91	19.75m	209.16	95.34	95.34	29279
17	43.65	Total>	79.91	20.75m	215.55	98.46	98.46	29804
18	43.20	Total>	88.91	23.00m	229.93	106.58	106.58	30985
19	43.00	Total>	92.91	24.00m	236.32	110.58	110.58	31511
20	42.50	Total>	102.92	26.50m	252.30	121.22	121.22	32824
21	42.00	Total>	112.92	29.00m	268.28	132.40	132.40	34136
22	41.50	Total>	122.93	31.50m	284.27	143.81	143.81	35449
23	41.13	Total>	130.43	33.37m	296.25	152.42	152.42	36434
24	40.75	Total>	137.94	35.25m	308.24	161.06	161.06	37419

Note: 41.07a Soil pressure at active limit
 84.68p Soil pressure at passive limit

Units: kN,m

Stage No.3 Excav. to elev. 47.80 on RIGHT side

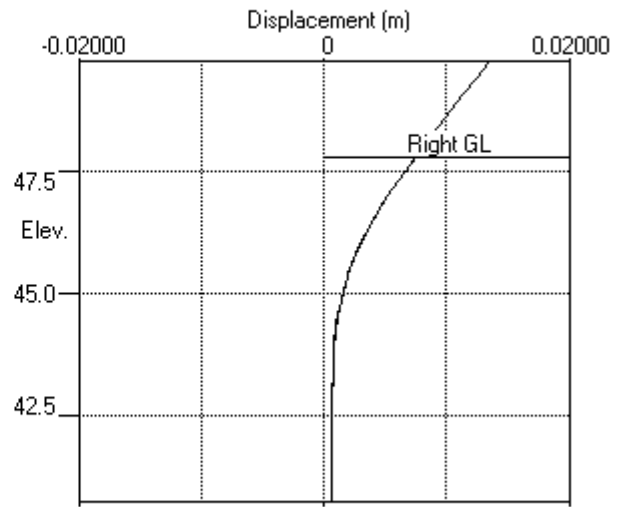
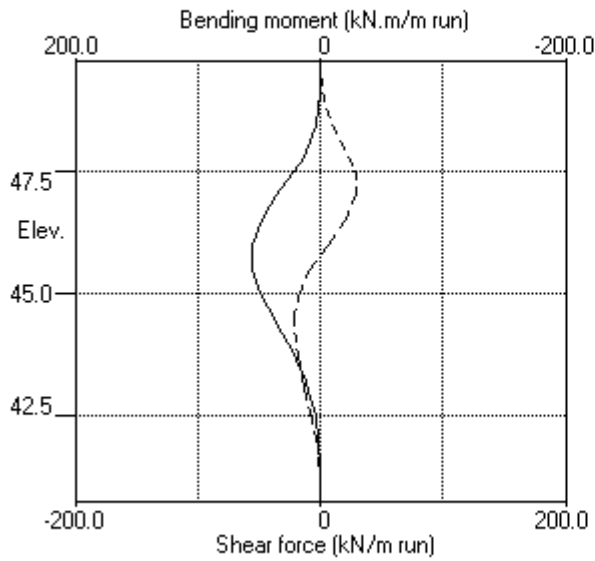

Stage No.3 Excav. to elev. 47.80 on RIGHT side

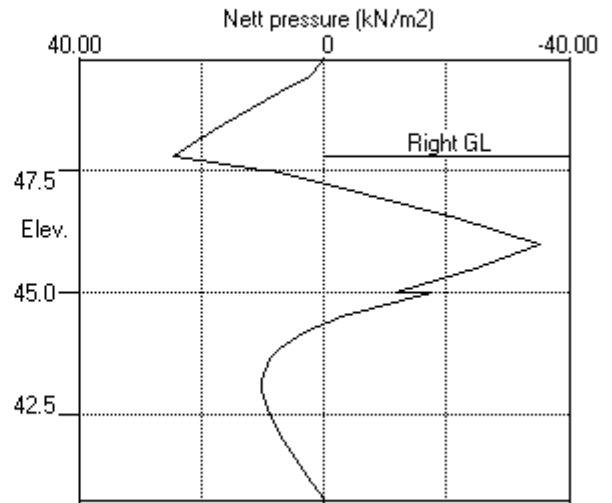
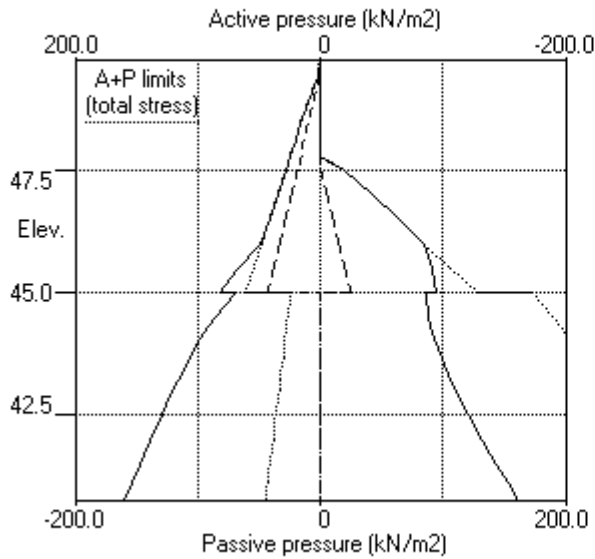

PILEDESIGNS LTD
 Program: WALLAP Version 6.06 Revision A51.B69.R54
 Licensed from GEOSOLVE
 Data filename/Run ID: Hampstead_Wall_5_450mm_rev_01_ULS1
 Hampstead - 24-26 Redington Gardens
 Wall 5, Secant-ULS1, 450 dia @ 650 - run 01

Sheet No.
 Job No. 21495
 Made by : DBS
 Date: 1-10-2018
 Checked :

Units: kN,m

Stage No. 6 Excavate to elevation 43.20 on RIGHT side

BENDING MOMENT and DISPLACEMENT ANALYSIS of Fully Embedded Wall

Analysis options

Length of wall perpendicular to section = 50.00m
 Subgrade reaction model - Boussinesq Influence coefficients
 Soil deformations are elastic until the active or passive limit is reached
 Open Tension Crack analysis - No

Rigid boundaries: Left side 50.00 from wall
 Right side 50.00 from wall

Limit State: ULS DA1 Combination 1

Calculated Bending Moments and Strut Forces are to be multiplied by a factor of 1.35 to obtain values for structural design. See summary for factored values.

Node no.	Y coord	Nett pressure kN/m2	Wall disp. m	Wall rotation rad.	Shear force kN/m	Bending moment kN.m/m	Strut forces kN/m	EI of wall kN.m2/m
1	49.75	0.00	0.006	-1.44E-03	0.0	0.0		60696
2	49.40	25.08	0.007	-1.44E-03	4.4	0.6		60696
3	49.08	35.79	0.007	-1.45E-03	14.3	3.0		60696
4	48.75	30.82	0.008	-1.49E-03	25.1	9.7		60696
5	48.42	25.56	0.008	-1.57E-03	34.3	19.5		60696
6	48.10	20.77	0.009	-1.70E-03	41.8	32.1	134.7	60696
		20.77	0.009	-1.70E-03	-92.9	32.1		
7	47.80	24.70	0.009	-1.80E-03	-86.1	5.2		60696
8	47.50	28.58	0.010	-1.76E-03	-78.1	-19.4		60696
		28.16	0.010	-1.76E-03	-78.1	-19.4		
9	47.00	34.65	0.010	-1.46E-03	-62.4	-54.7		60696
10	46.50	41.07	0.011	-9.01E-04	-43.4	-81.3		60696
11	46.00	47.44	0.011	-1.67E-04	-21.3	-96.8		60696
12	45.50	53.79	0.011	6.45E-04	4.0	-100.6		60696
13	45.00	60.11	0.011	1.44E-03	32.5	-92.2		60696
		23.75	0.011	1.44E-03	32.5	-92.2		
14	44.50	26.25	0.010	2.12E-03	45.0	-73.6		60696
15	44.17	27.88	0.009	2.47E-03	53.8	-57.7		60696
16	43.85	29.50	0.008	2.73E-03	63.1	-38.8		60696
17	43.65	30.50	0.008	2.83E-03	69.1	-25.6		60696
18	43.20	32.75	0.006	2.90E-03	83.3	8.5		60696
		-108.26	0.006	2.90E-03	83.3	8.5		
19	43.00	-109.92	0.006	2.84E-03	61.5	23.6		60696
20	42.50	-97.11	0.004	2.58E-03	9.7	40.3		60696
21	42.00	-46.44	0.003	2.26E-03	-26.1	38.4		60696
22	41.50	6.95	0.002	2.02E-03	-36.0	19.5		60696
23	41.13	46.58	0.001	1.94E-03	-26.0	6.5		60696
24	40.75	91.97	0.001	1.92E-03	0.0	0.0		---

At elev. 48.10 Strut force = 134.7 kN/strut = 134.7 kN/m run

Node no.	Y coord	Effective stresses					Total earth pressure kN/m2	Coeff. of subgrade reaction kN/m3
		Water press. kN/m2	Vertic -al kN/m2	Active limit kN/m2	Passive limit kN/m2	Earth pressure kN/m2		
1	49.75	0.00	0.00	0.00	0.00	0.00	0.00	6489
2	49.40	0.00	7.29	2.45	25.08	25.08	25.08p	6489
3	49.08	3.19	12.14	4.09	41.78	32.60	35.79	6489
4	48.75	6.38	16.54	5.57	56.94	24.44	30.82	6489
5	48.42	9.56	20.37	6.86	70.12	15.99	25.56	6489
6	48.10	12.75	23.80	8.01	81.93	8.01	20.77a	2350

(continued)

Stage No.6 Excavate to elevation 43.20 on RIGHT side

Node no.	Y coord	Effective stresses					Total earth pressure	Coeff. of subgrade reaction
		Water press.	Vertic -al	Active limit	Passive limit	Earth pressure		
		kN/m2	kN/m2	kN/m2	kN/m2	kN/m2	kN/m2	kN/m3
7	47.80	15.70	26.74	9.00	92.04	9.00	24.70a	2350
8	47.50	18.64	29.52	9.94	101.62	9.94	28.58a	2350
		18.64	29.52	9.52	107.66	9.52	28.16a	6750
9	47.00	23.54	34.42	11.10	125.52	11.10	34.65a	6750
10	46.50	28.45	39.12	12.62	142.65	12.62	41.07a	6750
11	46.00	33.35	43.68	14.09	159.28	14.09	47.44a	6750
12	45.50	38.26	48.14	15.53	175.57	15.53	53.79a	6750
13	45.00	43.16	52.55	16.95	191.63	16.95	60.11a	6750
		Total>	95.71	23.75m	215.22	23.75	23.75a	13615
14	44.50	Total>	105.48	26.25m	230.96	26.25	26.25a	14296
15	44.17	Total>	111.81	27.88m	241.18	27.88	27.88a	14739
16	43.85	Total>	118.14	29.50m	251.39	29.50	29.50a	15181
17	43.65	Total>	122.03	30.50m	257.67	30.50	30.50a	15453
18	43.20	Total>	130.77	32.75m	271.80	32.75	32.75a	16066
19	43.00	Total>	134.66	33.75m	278.07	37.48	37.48	16338
20	42.50	Total>	144.37	36.25m	293.76	66.27	66.27	17019
21	42.00	Total>	154.09	38.75m	309.46	94.08	94.08	17700
22	41.50	Total>	163.82	41.25m	325.16	120.80	120.80	18381
23	41.13	Total>	171.12	43.13m	336.94	140.70	140.70	18891
24	40.75	Total>	176.43	45.00m	346.74	162.62	162.62	154392

Node no.	Y coord	Effective stresses					Total earth pressure	Coeff. of subgrade reaction
		Water press.	Vertic -al	Active limit	Passive limit	Earth pressure		
		kN/m2	kN/m2	kN/m2	kN/m2	kN/m2	kN/m2	kN/m3
1	49.75	0.00	0.00	0.00	0.00	0.00	0.00	0.0
2	49.40	0.00	0.00	0.00	0.00	0.00	0.00	0.0
3	49.08	0.00	0.00	0.00	0.00	0.00	0.00	0.0
4	48.75	0.00	0.00	0.00	0.00	0.00	0.00	0.0
5	48.42	0.00	0.00	0.00	0.00	0.00	0.00	0.0
6	48.10	0.00	0.00	0.00	0.00	0.00	0.00	0.0
7	47.80	0.00	0.00	0.00	0.00	0.00	0.00	0.0
8	47.50	0.00	0.00	0.00	0.00	0.00	0.00	0.0
9	47.00	0.00	0.00	0.00	0.00	0.00	0.00	0.0
10	46.50	0.00	0.00	0.00	0.00	0.00	0.00	0.0
11	46.00	0.00	0.00	0.00	0.00	0.00	0.00	0.0
12	45.50	0.00	0.00	0.00	0.00	0.00	0.00	0.0
13	45.00	0.00	0.00	0.00	0.00	0.00	0.00	0.0
14	44.50	0.00	0.00	0.00	0.00	0.00	0.00	0.0
15	44.17	0.00	0.00	0.00	0.00	0.00	0.00	0.0
16	43.85	0.00	0.00	0.00	0.00	0.00	0.00	0.0
17	43.65	0.00	0.00	0.00	0.00	0.00	0.00	0.0
18	43.20	0.00	0.00	0.00	0.00	0.00	0.00	0.0
		Total>	0.00	0.00	141.01	141.01	141.01p	34422
19	43.00	Total>	4.00	1.00m	147.40	147.40	147.40p	35006
20	42.50	Total>	14.00	3.50m	163.37	163.37	163.37p	36464
21	42.00	Total>	24.00	6.00m	179.35	140.52	140.52	37923
22	41.50	Total>	34.00	8.50m	195.33	113.85	113.85	39381
23	41.13	Total>	41.50	10.38m	207.31	94.12	94.12	40475
24	40.75	Total>	49.01	12.25m	219.30	70.64	70.64	322920

Note: 32.75a Soil pressure at active limit
 163.37p Soil pressure at passive limit

Units: kN,m

Stage No.6 Excav. to elev. 43.20 on RIGHT side

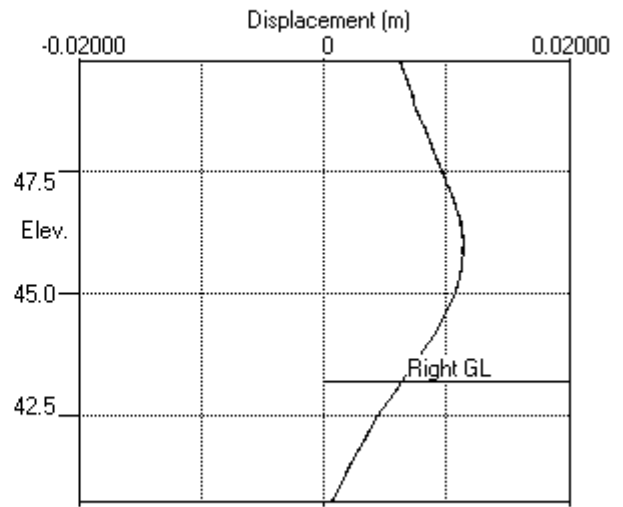
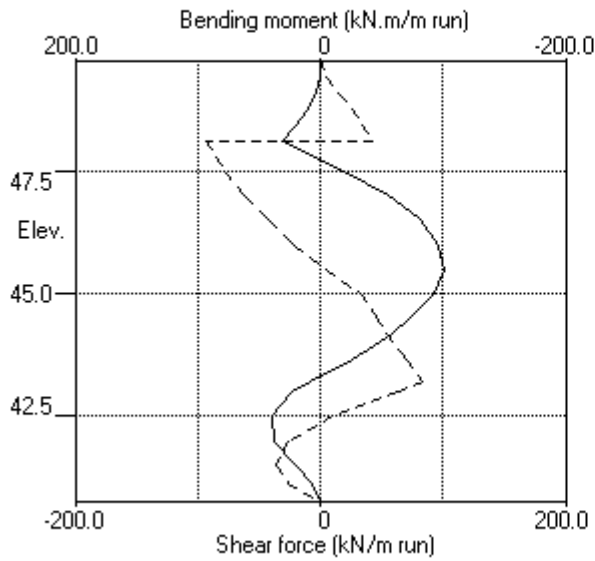

Stage No.6 Excav. to elev. 43.20 on RIGHT side

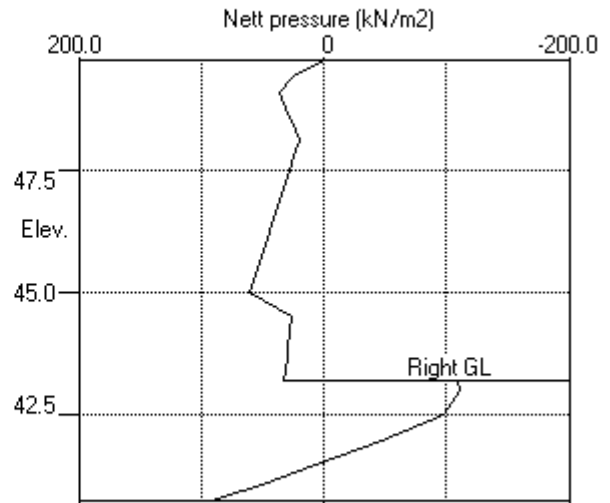
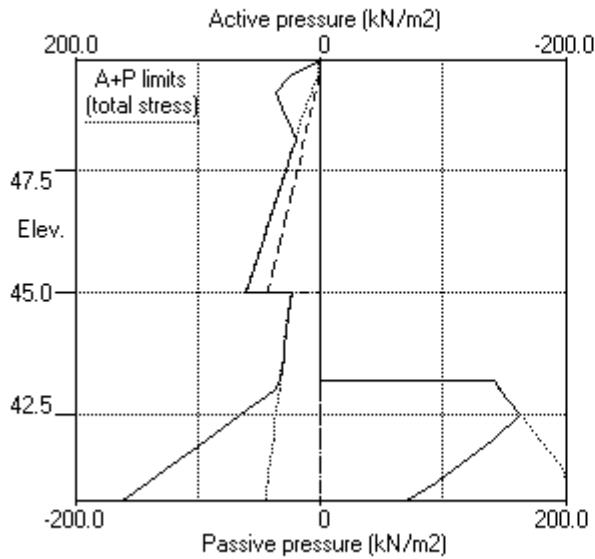

PILEDESIGNS LTD
 Program: WALLAP Version 6.06 Revision A51.B69.R54
 Licensed from GEOSOLVE
 Data filename/Run ID: Hampstead_Wall_5_450mm_rev_01_ULS1
 Hampstead - 24-26 Redington Gardens
 Wall 5, Secant-ULS1, 450 dia @ 650 - run 01

Sheet No.
 Job No. 21495
 Made by : DBS
 Date: 1-10-2018
 Checked :

Units: kN,m

Stage No. 7 Fill to elevation 43.65 on RIGHT side with soil type 1

BENDING MOMENT and DISPLACEMENT ANALYSIS of Fully Embedded Wall

Analysis options

Length of wall perpendicular to section = 50.00m
 Subgrade reaction model - Boussinesq Influence coefficients
 Soil deformations are elastic until the active or passive limit is reached
 Open Tension Crack analysis - No

Rigid boundaries: Left side 50.00 from wall
 Right side 50.00 from wall

Limit State: ULS DA1 Combination 1

Calculated Bending Moments and Strut Forces are to be multiplied by a factor of 1.35 to obtain values for structural design. See summary for factored values.

Node no.	Y coord	Nett pressure kN/m2	Wall disp. m	Wall rotation rad.	Shear force kN/m	Bending moment kN.m/m	Strut forces kN/m	EI of wall kN.m2/m
1	49.75	0.00	0.006	-1.44E-03	0.0	0.0		60696
2	49.40	25.06	0.007	-1.44E-03	4.4	0.6		60696
3	49.08	35.78	0.007	-1.45E-03	14.3	3.0		60696
4	48.75	30.81	0.008	-1.49E-03	25.1	9.6		60696
5	48.42	25.55	0.008	-1.56E-03	34.3	19.5		60696
6	48.10	20.77	0.009	-1.70E-03	41.8	32.1	135.0	60696
		20.77	0.009	-1.70E-03	-93.3	32.1		
7	47.80	24.70	0.009	-1.79E-03	-86.4	5.1		60696
8	47.50	28.58	0.010	-1.76E-03	-78.4	-19.7		60696
		28.17	0.010	-1.76E-03	-78.4	-19.7		
9	47.00	34.68	0.010	-1.45E-03	-62.7	-55.1		60696
10	46.50	41.13	0.011	-8.90E-04	-43.8	-81.9		60696
11	46.00	47.56	0.011	-1.51E-04	-21.6	-97.5		60696
12	45.50	53.99	0.011	6.68E-04	3.8	-101.6		60696
13	45.00	60.43	0.011	1.47E-03	32.4	-93.2		60696
		24.37	0.011	1.47E-03	32.4	-93.2		
14	44.50	27.21	0.010	2.16E-03	45.3	-74.6		60696
15	44.17	29.11	0.009	2.51E-03	54.4	-58.5		60696
16	43.85	31.05	0.008	2.78E-03	64.2	-39.3		60696
17	43.65	32.26	0.008	2.88E-03	70.5	-25.9		60696
18	43.20	32.29	0.006	2.95E-03	85.1	9.0		60696
		-111.51	0.006	2.95E-03	85.1	9.0		
19	43.00	-112.72	0.006	2.89E-03	62.6	24.3		60696
20	42.50	-98.81	0.004	2.62E-03	9.7	41.3		60696
21	42.00	-47.13	0.003	2.29E-03	-26.7	39.1		60696
22	41.50	7.20	0.002	2.05E-03	-36.7	19.9		60696
23	41.13	47.51	0.001	1.96E-03	-26.5	6.6		60696
24	40.75	93.60	0.000	1.94E-03	0.0	0.0		---

At elev. 48.10 Strut force = 135.0 kN/strut = 135.0 kN/m run

Node no.	Y coord	LEFT side						Total earth pressure kN/m2	Coeff. of subgrade reaction kN/m3
		Water press. kN/m2	Vertic -al kN/m2	Active limit kN/m2	Passive limit kN/m2	Earth pressure kN/m2	Earth pressure kN/m2		
1	49.75	0.00	0.00	0.00	0.00	0.00	0.00	5970	
2	49.40	0.00	7.29	2.45	25.08	25.06	25.06	5970	
3	49.08	3.19	12.14	4.09	41.78	32.59	35.78	5970	
4	48.75	6.38	16.54	5.57	56.94	24.43	30.81	5970	
5	48.42	9.56	20.37	6.86	70.12	15.99	25.55	5970	
6	48.10	12.75	23.80	8.01	81.93	8.01	20.77a	5970	

(continued)

Stage No.7 Fill to elevation 43.65 on RIGHT side with soil type 1

Node no.	Y coord	----- LEFT side -----					Total earth pressure kN/m2	Coeff. of subgrade reaction kN/m3
		Water press. kN/m2	Vertic -al kN/m2	Effective Active limit kN/m2	Effective Passive limit kN/m2	Earth pressure kN/m2		
7	47.80	15.70	26.74	9.00	92.04	9.00	24.70a	2984
8	47.50	18.64	29.52	9.94	101.62	9.94	28.58a	2984
		18.64	29.52	9.52	107.66	9.53	28.17	8597
9	47.00	23.54	34.42	11.10	125.52	11.13	34.68	8597
10	46.50	28.45	39.12	12.62	142.65	12.68	41.13	8597
11	46.00	33.35	43.68	14.09	159.28	14.21	47.56	8597
12	45.50	38.26	48.14	15.53	175.57	15.73	53.99	8597
13	45.00	43.16	52.55	16.95	191.63	17.27	60.43	8597
		Total>	95.71	23.75m	215.22	24.37	24.37	16852
14	44.50	Total>	105.48	26.25m	230.96	27.21	27.21	17694
15	44.17	Total>	111.81	27.88m	241.18	29.11	29.11	18242
16	43.85	Total>	118.14	29.50m	251.39	31.05	31.05	18790
17	43.65	Total>	122.03	30.50m	257.67	32.26	32.26	19127
18	43.20	Total>	130.77	32.75m	271.80	35.01	35.01	19885
19	43.00	Total>	134.66	33.75m	278.07	39.97	39.97	20222
20	42.50	Total>	144.37	36.25m	293.76	69.31	69.31	21065
21	42.00	Total>	154.09	38.75m	309.46	97.63	97.63	21907
22	41.50	Total>	163.82	41.25m	325.16	124.82	124.82	22750
23	41.13	Total>	171.12	43.13m	336.94	145.06	145.06	23382
24	40.75	Total>	176.43	45.00m	346.74	167.32	167.32	24014

Node no.	Y coord	----- RIGHT side -----					Total earth pressure kN/m2	Coeff. of subgrade reaction kN/m3
		Water press. kN/m2	Vertic -al kN/m2	Effective Active limit kN/m2	Effective Passive limit kN/m2	Earth pressure kN/m2		
1	49.75	0.00	0.00	0.00	0.00	0.00	0.00	0.0
2	49.40	0.00	0.00	0.00	0.00	0.00	0.00	0.0
3	49.08	0.00	0.00	0.00	0.00	0.00	0.00	0.0
4	48.75	0.00	0.00	0.00	0.00	0.00	0.00	0.0
5	48.42	0.00	0.00	0.00	0.00	0.00	0.00	0.0
6	48.10	0.00	0.00	0.00	0.00	0.00	0.00	0.0
7	47.80	0.00	0.00	0.00	0.00	0.00	0.00	0.0
8	47.50	0.00	0.00	0.00	0.00	0.00	0.00	0.0
9	47.00	0.00	0.00	0.00	0.00	0.00	0.00	0.0
10	46.50	0.00	0.00	0.00	0.00	0.00	0.00	0.0
11	46.00	0.00	0.00	0.00	0.00	0.00	0.00	0.0
12	45.50	0.00	0.00	0.00	0.00	0.00	0.00	0.0
13	45.00	0.00	0.00	0.00	0.00	0.00	0.00	0.0
14	44.50	0.00	0.00	0.00	0.00	0.00	0.00	0.0
15	44.17	0.00	0.00	0.00	0.00	0.00	0.00	0.0
16	43.85	0.00	0.00	0.00	0.00	0.00	0.00	0.0
17	43.65	0.00	0.00	0.00	0.00	0.00	0.00	0.0
		0.00	0.00	0.00	0.00	0.00	0.00	2984
18	43.20	0.00	8.10	2.73	27.88	2.73	2.73a	2984
		Total>	8.10	2.25m	149.11	146.53	146.53	19885
19	43.00	Total>	12.10	3.25m	155.50	152.69	152.69	20222
20	42.50	Total>	22.10	5.75m	171.48	168.12	168.12	21065
21	42.00	Total>	32.10	8.25m	187.45	144.75	144.75	21907
22	41.50	Total>	42.10	10.75m	203.43	117.62	117.62	22750
23	41.13	Total>	49.61	12.63m	215.42	97.54	97.54	23382
24	40.75	Total>	57.11	14.50m	227.40	73.72	73.72	24014

Run ID. Hampstead_Wall_5_450mm_rev_01_ULS1
Hampstead - 24-26 Redington Gardens
Wall 5, Secant-ULS1, 450 dia @ 650 - run 01

| Sheet No.
| Date: 1-10-2018
| Checked :

(continued)

Stage No.7 Fill to elevation 43.65 on RIGHT side with soil type 1
Note: 2.73a Soil pressure at active limit
123.45p Soil pressure at passive limit

Units: kN,m

Stage No.7 Fill to elev. 43.65 on RIGHT side

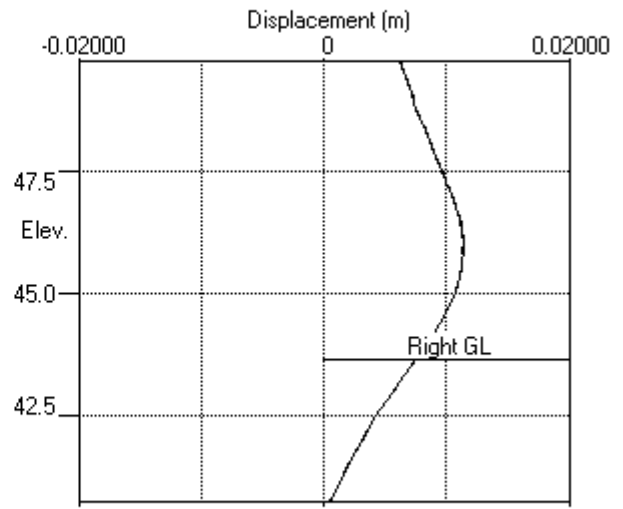
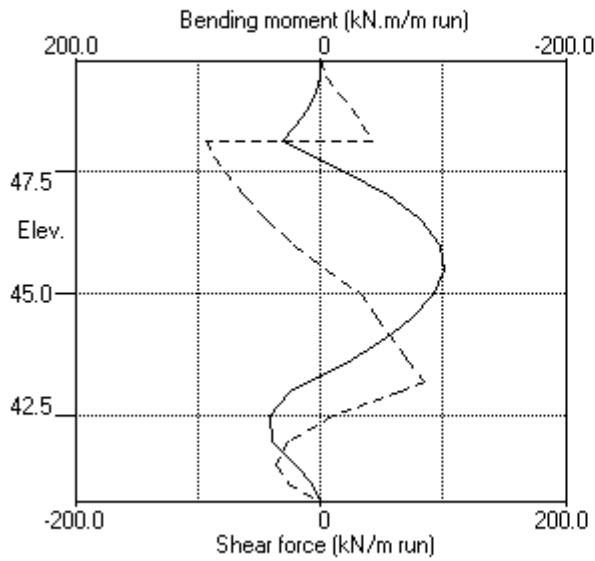

Stage No.7 Fill to elev. 43.65 on RIGHT side

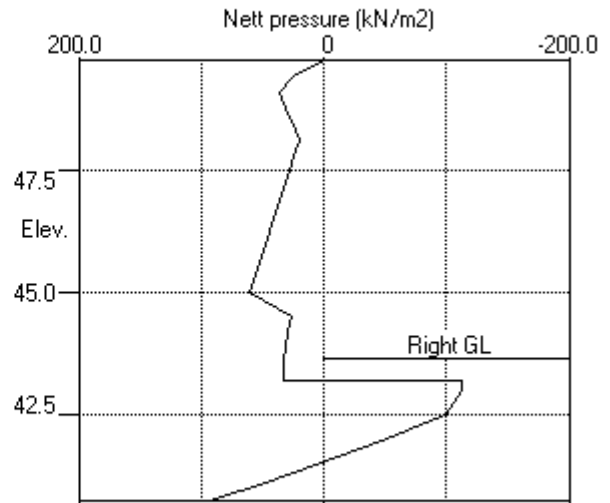
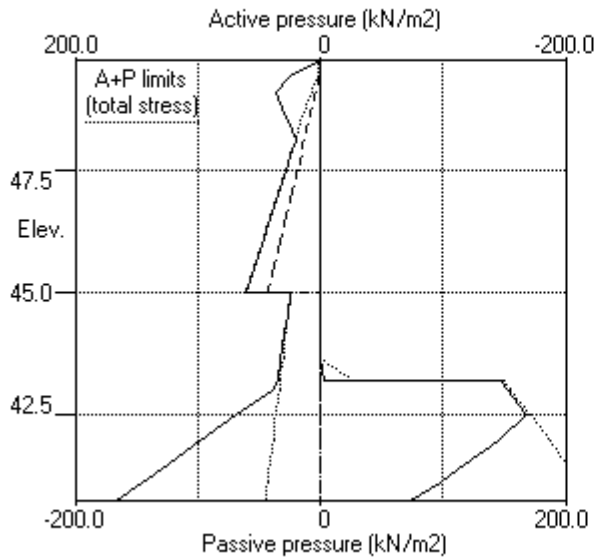

PILEDESIGNS LTD
 Program: WALLAP Version 6.06 Revision A51.B69.R54
 Licensed from GEOSOLVE
 Data filename/Run ID: Hampstead_Wall_5_450mm_rev_01_ULS1
 Hampstead - 24-26 Redington Gardens
 Wall 5, Secant-ULS1, 450 dia @ 650 - run 01

Sheet No.
 Job No. 21495
 Made by : DBS
 Date: 1-10-2018
 Checked :

Units: kN,m

Stage No. 9 Change EI of wall to 43355 kN.m²/m run
 Yield moment not defined
 Allow wall to relax with new modulus value

BENDING MOMENT and DISPLACEMENT ANALYSIS of Fully Embedded Wall

Analysis options

Length of wall perpendicular to section = 50.00m
 Subgrade reaction model - Boussinesq Influence coefficients
 Soil deformations are elastic until the active or passive limit is reached
 Open Tension Crack analysis - No

Rigid boundaries: Left side 50.00 from wall
 Right side 50.00 from wall

Limit State: ULS DAL Combination 1

Calculated Bending Moments and Strut Forces are to be multiplied by a factor
 of 1.35 to obtain values for structural design. See summary for factored values.

Node no.	Y coord	Nett pressure kN/m ²	Wall disp. m	Wall rotation rad.	Shear force kN/m	Bending moment kN.m/m	Strut forces kN/m	EI of wall kN.m ² /m
1	49.75	0.00	0.006	-1.68E-03	0.0	0.0		43355
2	49.40	25.08	0.006	-1.69E-03	4.4	0.6		43355
3	49.08	37.48	0.007	-1.70E-03	14.6	3.0		43355
4	48.75	32.01	0.007	-1.75E-03	25.8	9.8		43355
5	48.42	26.21	0.008	-1.86E-03	35.3	19.9		43355
6	48.10	20.79	0.009	-2.06E-03	42.9	32.8	131.3	43355
		20.79	0.009	-2.06E-03	-88.4	32.8		
7	47.80	24.70	0.009	-2.20E-03	-81.6	6.9		43355
8	47.50	28.58	0.010	-2.17E-03	-73.6	-16.7		43355
		28.16	0.010	-2.17E-03	-73.6	-16.7		
9	47.00	34.65	0.011	-1.79E-03	-57.9	-50.3		43355
10	46.50	41.07	0.012	-1.09E-03	-39.0	-75.2		43355
11	46.00	47.44	0.012	-1.73E-04	-16.8	-89.0		43355
12	45.50	53.79	0.012	8.33E-04	8.5	-91.1		43355
13	45.00	60.11	0.011	1.78E-03	37.0	-81.0		43355
		23.75	0.011	1.78E-03	37.0	-81.0		
14	44.50	26.25	0.010	2.56E-03	49.5	-60.6		43355
15	44.17	27.88	0.009	2.92E-03	58.2	-43.6		43355
16	43.85	30.58	0.008	3.14E-03	67.7	-23.5	20.7	43355
		30.58	0.008	3.14E-03	47.1	-23.5		
17	43.65	33.28	0.008	3.20E-03	53.5	-12.7		43355
18	43.20	36.28	0.006	3.15E-03	69.1	16.3		43355
		-103.53	0.006	3.15E-03	69.1	16.3		
19	43.00	-102.84	0.005	3.04E-03	48.5	29.3		43355
20	42.50	-86.65	0.004	2.62E-03	1.1	41.7		43355
21	42.00	-36.29	0.003	2.16E-03	-29.6	37.4		43355
22	41.50	13.76	0.002	1.85E-03	-35.3	18.0		43355
23	41.13	49.76	0.001	1.75E-03	-23.3	5.6		43355
24	40.75	74.75	0.001	1.73E-03	0.0	0.0		---
At elev. 48.10		Strut force =		131.3 kN/strut =	131.3 kN/m run			
At elev. 43.85		Strut force =		20.7 kN/strut =	20.7 kN/m run			

(continued)

Stage No.9 Change EI of wall to 43355 kN.m2/m run
Yield moment not defined
Allow wall to relax with new modulus value

Node no.	Y coord	LEFT side					Total earth pressure	Coeff. of subgrade reaction
		Water press.	Vertic -al	Active limit	Passive limit	Earth pressure		
		kN/m2	kN/m2	kN/m2	kN/m2	kN/m2	kN/m2	kN/m3
1	49.75	0.00	0.00	0.00	0.00	0.00	0.00	6063
2	49.40	0.00	7.29	2.45	25.08	25.08	25.08p	6063
3	49.08	3.19	12.14	4.09	41.78	34.29	37.48	6063
4	48.75	6.38	16.54	5.57	56.94	25.63	32.01	6063
5	48.42	9.56	20.37	6.86	70.12	16.64	26.21	6063
6	48.10	12.75	23.80	8.01	81.93	8.03	20.79	6063
7	47.80	15.70	26.74	9.00	92.04	9.00	24.70a	3020
8	47.50	18.64	29.52	9.94	101.62	9.94	28.58a	3020
		18.64	29.52	9.52	107.66	9.52	28.16a	8704
9	47.00	23.54	34.42	11.10	125.52	11.10	34.65a	8704
10	46.50	28.45	39.12	12.62	142.65	12.62	41.07a	8704
11	46.00	33.35	43.68	14.09	159.28	14.09	47.44a	8704
12	45.50	38.26	48.14	15.53	175.57	15.53	53.79a	8704
13	45.00	43.16	52.55	16.95	191.63	16.95	60.11a	8704
		Total>	95.71	23.75m	215.22	23.75	23.75a	17041
14	44.50	Total>	105.48	26.25m	230.96	26.25	26.25a	17893
15	44.17	Total>	111.81	27.88m	241.18	27.88	27.88a	18447
16	43.85	Total>	118.14	29.50m	251.39	30.58	30.58	19001
17	43.65	Total>	122.03	30.50m	257.67	33.28	33.28	23814
18	43.20	Total>	130.77	32.75m	271.80	39.00	39.00	24758
19	43.00	Total>	134.66	33.75m	278.07	44.91	44.91	25178
20	42.50	Total>	144.37	36.25m	293.76	75.39	75.39	26227
21	42.00	Total>	154.09	38.75m	309.46	103.04	103.04	27276
22	41.50	Total>	163.82	41.25m	325.16	128.10	128.10	28325
23	41.13	Total>	171.12	43.13m	336.94	146.18	146.18	29112
24	40.75	Total>	176.43	45.00m	346.74	157.90	157.90	226624

Node no.	Y coord	RIGHT side					Total earth pressure	Coeff. of subgrade reaction
		Water press.	Vertic -al	Active limit	Passive limit	Earth pressure		
		kN/m2	kN/m2	kN/m2	kN/m2	kN/m2	kN/m2	kN/m3
1	49.75	0.00	0.00	0.00	0.00	0.00	0.00	0.0
2	49.40	0.00	0.00	0.00	0.00	0.00	0.00	0.0
3	49.08	0.00	0.00	0.00	0.00	0.00	0.00	0.0
4	48.75	0.00	0.00	0.00	0.00	0.00	0.00	0.0
5	48.42	0.00	0.00	0.00	0.00	0.00	0.00	0.0
6	48.10	0.00	0.00	0.00	0.00	0.00	0.00	0.0
7	47.80	0.00	0.00	0.00	0.00	0.00	0.00	0.0
8	47.50	0.00	0.00	0.00	0.00	0.00	0.00	0.0
9	47.00	0.00	0.00	0.00	0.00	0.00	0.00	0.0
10	46.50	0.00	0.00	0.00	0.00	0.00	0.00	0.0
11	46.00	0.00	0.00	0.00	0.00	0.00	0.00	0.0
12	45.50	0.00	0.00	0.00	0.00	0.00	0.00	0.0
13	45.00	0.00	0.00	0.00	0.00	0.00	0.00	0.0
14	44.50	0.00	0.00	0.00	0.00	0.00	0.00	0.0
15	44.17	0.00	0.00	0.00	0.00	0.00	0.00	0.0
16	43.85	0.00	0.00	0.00	0.00	0.00	0.00	0.0
17	43.65	0.00	0.00	0.00	0.00	0.00	0.00	0.0
		0.00	0.00	0.00	0.00	0.00	0.00	3783
18	43.20	0.00	8.10	2.73	27.88	2.73	2.73a	3783
		Total>	8.10	2.25m	149.11	142.54	142.54	24758

(continued)

Stage No.9 Change EI of wall to 43355 kN.m2/m run
 Yield moment not defined
 Allow wall to relax with new modulus value

Node no.	Y coord	----- RIGHT side -----						Total earth pressure	Coeff. of subgrade reaction
		Water press.	Vertical	Effective Active limit	Effective Passive limit	Earth pressure	Earth pressure		
		kN/m2	kN/m2	kN/m2	kN/m2	kN/m2	kN/m2	kN/m3	
19	43.00	Total>	12.10	3.25m	155.50	147.75	147.75	25178	
20	42.50	Total>	22.10	5.75m	171.48	162.03	162.03	26227	
21	42.00	Total>	32.10	8.25m	187.45	139.34	139.34	27276	
22	41.50	Total>	42.10	10.75m	203.43	114.34	114.34	28325	
23	41.13	Total>	49.61	12.63m	215.42	96.42	96.42	29112	
24	40.75	Total>	57.11	14.50m	227.40	83.15	83.15	226624	

Note: 2.73a Soil pressure at active limit
 25.08p Soil pressure at passive limit

Units: kN,m

Stage No.9 Change EI of wall to 43355kN.m2/m run

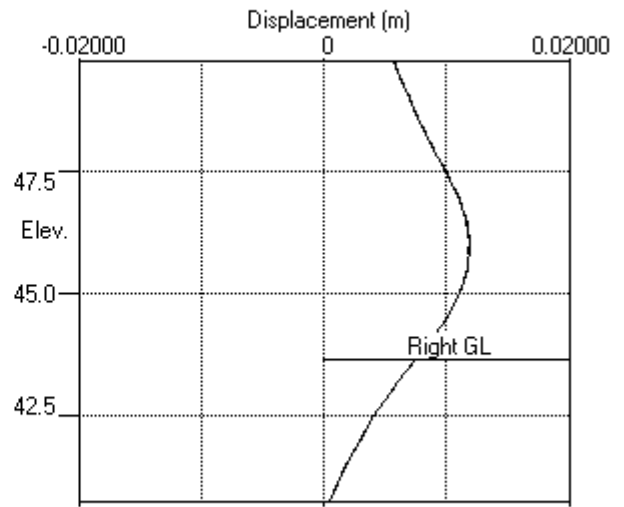
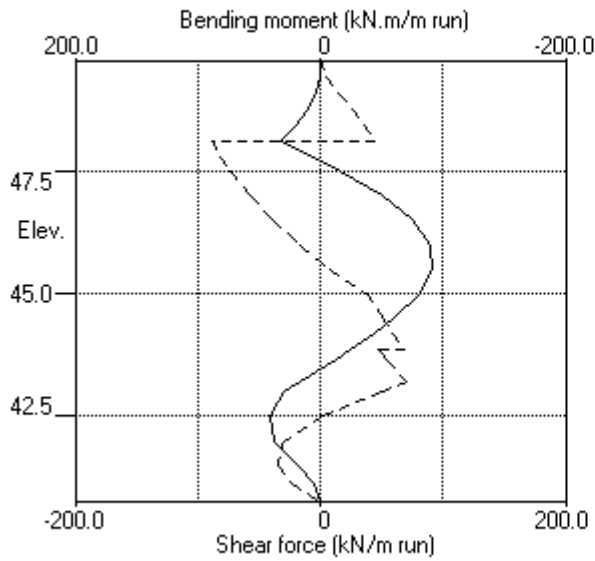

Stage No.9 Change EI of wall to 43355kN.m2/m run

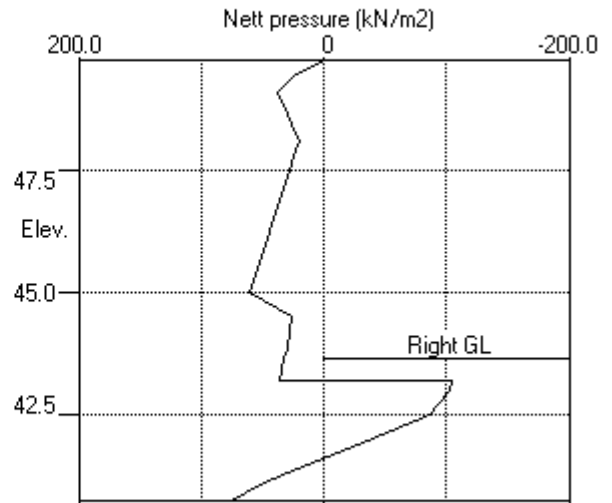
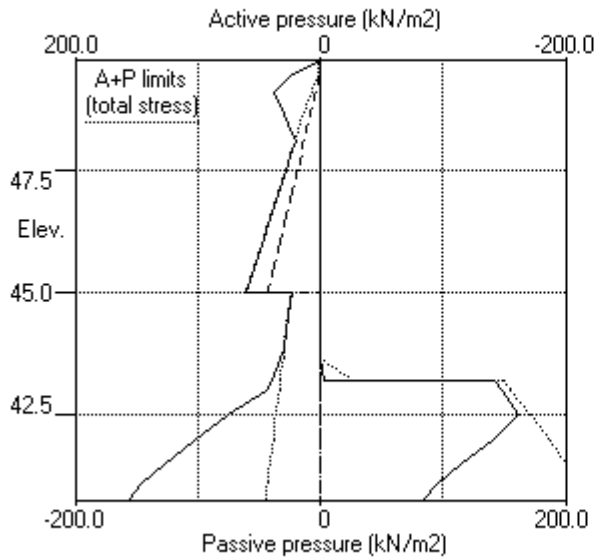

PILEDESIGNS LTD
 Program: WALLAP Version 6.06 Revision A51.B69.R54
 Licensed from GEOSOLVE
 Data filename/Run ID: Hampstead_Wall_5_450mm_rev_01_ULS1
 Hampstead - 24-26 Redington Gardens
 Wall 5, Secant-ULS1, 450 dia @ 650 - run 01

Sheet No.
 Job No. 21495
 Made by : DBS
 Date: 1-10-2018
 Checked :

Units: kN,m

Stage No. 10 Change properties of soil type 3 to soil type 4
 Ko pressures will not be reset

BENDING MOMENT and DISPLACEMENT ANALYSIS of Fully Embedded Wall

Analysis options

Length of wall perpendicular to section = 50.00m
 Subgrade reaction model - Boussinesq Influence coefficients
 Soil deformations are elastic until the active or passive limit is reached
 Open Tension Crack analysis - No

Rigid boundaries: Left side 50.00 from wall
 Right side 50.00 from wall

Limit State: ULS DA1 Combination 1

Calculated Bending Moments and Strut Forces are to be multiplied by a factor
 of 1.35 to obtain values for structural design. See summary for factored values.

Node no.	Y coord	Nett pressure kN/m ²	Wall disp. m	Wall rotation rad.	Shear force kN/m	Bending moment kN.m/m	Strut forces kN/m	EI of wall kN.m ² /m
1	49.75	0.00	0.006	-1.28E-03	0.0	0.0		43355
2	49.40	21.70	0.007	-1.29E-03	3.8	0.6		43355
3	49.08	34.94	0.007	-1.30E-03	13.0	2.7		43355
4	48.75	30.31	0.008	-1.34E-03	23.6	8.8		43355
5	48.42	25.37	0.008	-1.44E-03	32.7	18.1		43355
6	48.10	20.81	0.009	-1.62E-03	40.2	30.0	122.6	43355
		20.81	0.009	-1.62E-03	-82.5	30.0		
7	47.80	25.12	0.009	-1.75E-03	-75.6	6.0		43355
8	47.50	29.41	0.010	-1.72E-03	-67.4	-15.9		43355
		30.55	0.010	-1.72E-03	-67.4	-15.9		
9	47.00	38.93	0.010	-1.38E-03	-50.0	-46.0		43355
10	46.50	47.02	0.011	-7.52E-04	-28.6	-66.5		43355
11	46.00	54.62	0.011	3.45E-05	-3.1	-74.3		43355
12	45.50	61.44	0.011	8.28E-04	25.9	-68.7		43355
13	45.00	67.10	0.010	1.46E-03	58.0	-49.0		43355
		61.62	0.010	1.46E-03	58.0	-49.0		
14	44.50	68.23	0.009	1.78E-03	90.5	-13.1		43355
15	44.17	72.53	0.009	1.72E-03	113.3	19.5		43355
16	43.85	76.82	0.008	1.39E-03	137.6	59.9	233.3	43355
		76.82	0.008	1.39E-03	-95.7	59.9		
17	43.65	79.46	0.008	1.14E-03	-80.0	43.1		43355
18	43.20	76.62	0.008	8.02E-04	-44.9	16.7		43355
		59.05	0.008	8.02E-04	-44.9	16.7		
19	43.00	48.67	0.008	7.32E-04	-34.2	10.0		43355
20	42.50	33.79	0.007	6.73E-04	-13.5	-1.3		43355
21	42.00	18.90	0.007	6.86E-04	-0.4	-0.6		43355
22	41.50	4.02	0.007	7.01E-04	5.4	-1.1		43355
23	41.13	-7.15	0.006	7.10E-04	4.8	-0.1		43355
24	40.75	-18.32	0.006	7.12E-04	0.0	0.0		---
At elev. 48.10 Strut force =			122.6 kN/strut =	122.6 kN/m run				
At elev. 43.85 Strut force =			233.3 kN/strut =	233.3 kN/m run				

(continued)

Stage No.10 Change properties of soil type 3 to soil type 4
Ko pressures will not be reset

Node no.	Y coord	LEFT side					Total earth pressure kN/m2	Coeff. of subgrade reaction kN/m3
		Effective stresses						
		Water press. kN/m2	Vertic -al kN/m2	Active limit kN/m2	Passive limit kN/m2	Earth pressure kN/m2		
1	49.75	0.00	0.00	0.00	0.00	0.00	6431	
2	49.40	0.00	7.29	2.45	25.08	21.70	6431	
3	49.08	3.19	12.14	4.09	41.78	34.94	6431	
4	48.75	6.38	16.54	5.57	56.94	23.94	6431	
5	48.42	9.56	20.37	6.86	70.12	15.81	6431	
6	48.10	12.75	23.80	8.01	81.93	8.06	3018	
7	47.80	15.70	26.74	9.00	92.04	9.42	3018	
8	47.50	18.64	29.52	9.94	101.62	10.77	3018	
		18.64	29.52	9.52	107.66	11.91	8696	
9	47.00	23.54	34.42	11.10	125.52	15.38	8696	
10	46.50	28.45	39.12	12.62	142.65	18.57	8696	
11	46.00	33.35	43.68	14.09	159.28	21.27	8696	
12	45.50	38.26	48.14	15.53	175.57	23.18	8696	
13	45.00	43.16	52.55	16.95	191.63	23.93	8696	
		43.16	52.55	18.46	170.92	18.46	8928	
14	44.50	48.07	57.41	20.17	186.73	20.17	9375	
15	44.17	51.26	60.55	21.27	196.96	21.27	9665	
16	43.85	54.45	63.69	22.37	207.17	22.37	12111	
17	43.65	56.41	65.62	23.05	213.44	23.05	12328	
18	43.20	60.82	69.95	24.57	227.53	24.57	12817	
19	43.00	62.78	71.87	25.25	233.79	25.25	13035	
20	42.50	67.69	76.69	26.94	249.44	26.94	13578	
21	42.00	72.59	81.50	28.63	265.10	28.63	14121	
22	41.50	77.50	86.32	30.32	280.78	30.32	14664	
23	41.13	81.18	89.94	31.59	292.55	31.59	15071	
24	40.75	84.86	93.57	32.87	304.35	32.87	15479	

Node no.	Y coord	RIGHT side					Total earth pressure kN/m2	Coeff. of subgrade reaction kN/m3
		Effective stresses						
		Water press. kN/m2	Vertic -al kN/m2	Active limit kN/m2	Passive limit kN/m2	Earth pressure kN/m2		
1	49.75	0.00	0.00	0.00	0.00	0.00	0.0	
2	49.40	0.00	0.00	0.00	0.00	0.00	0.0	
3	49.08	0.00	0.00	0.00	0.00	0.00	0.0	
4	48.75	0.00	0.00	0.00	0.00	0.00	0.0	
5	48.42	0.00	0.00	0.00	0.00	0.00	0.0	
6	48.10	0.00	0.00	0.00	0.00	0.00	0.0	
7	47.80	0.00	0.00	0.00	0.00	0.00	0.0	
8	47.50	0.00	0.00	0.00	0.00	0.00	0.0	
9	47.00	0.00	0.00	0.00	0.00	0.00	0.0	
10	46.50	0.00	0.00	0.00	0.00	0.00	0.0	
11	46.00	0.00	0.00	0.00	0.00	0.00	0.0	
12	45.50	0.00	0.00	0.00	0.00	0.00	0.0	
13	45.00	0.00	0.00	0.00	0.00	0.00	0.0	
14	44.50	0.00	0.00	0.00	0.00	0.00	0.0	
15	44.17	0.00	0.00	0.00	0.00	0.00	0.0	
16	43.85	0.00	0.00	0.00	0.00	0.00	0.0	
17	43.65	0.00	0.00	0.00	0.00	0.00	0.0	
		0.00	0.00	0.00	0.00	0.00	3665	
18	43.20	0.00	8.10	2.73	27.88	8.78	3665	
		0.00	8.10	2.85	26.35	26.35	12817	
19	43.00	0.00	12.10	4.25	39.36	39.36	13035	

(continued)

Stage No.10 Change properties of soil type 3 to soil type 4
 Ko pressures will not be reset

Node no.	Y coord	----- RIGHT side -----					Total earth pressure	Coeff. of subgrade reaction
		Water press.	Vertic -al	Effective Active limit	Effective Passive limit	Earth pressure		
		kN/m2	kN/m2	kN/m2	kN/m2	kN/m2	kN/m2	kN/m3
20	42.50	4.90	17.20	6.04	55.93	55.93	60.84p	13578
21	42.00	9.81	22.29	7.83	72.51	72.51	82.32p	14121
22	41.50	14.71	27.39	9.62	89.09	89.09	103.80p	14664
23	41.13	18.39	31.21	10.96	101.53	101.53	119.92p	15071
24	40.75	22.07	35.04	12.31	113.97	113.97	136.04p	15479

Note: 117.72a Soil pressure at active limit
 136.04p Soil pressure at passive limit

Units: kN,m

Stage No.10 Change soil type 3 to soil type 4

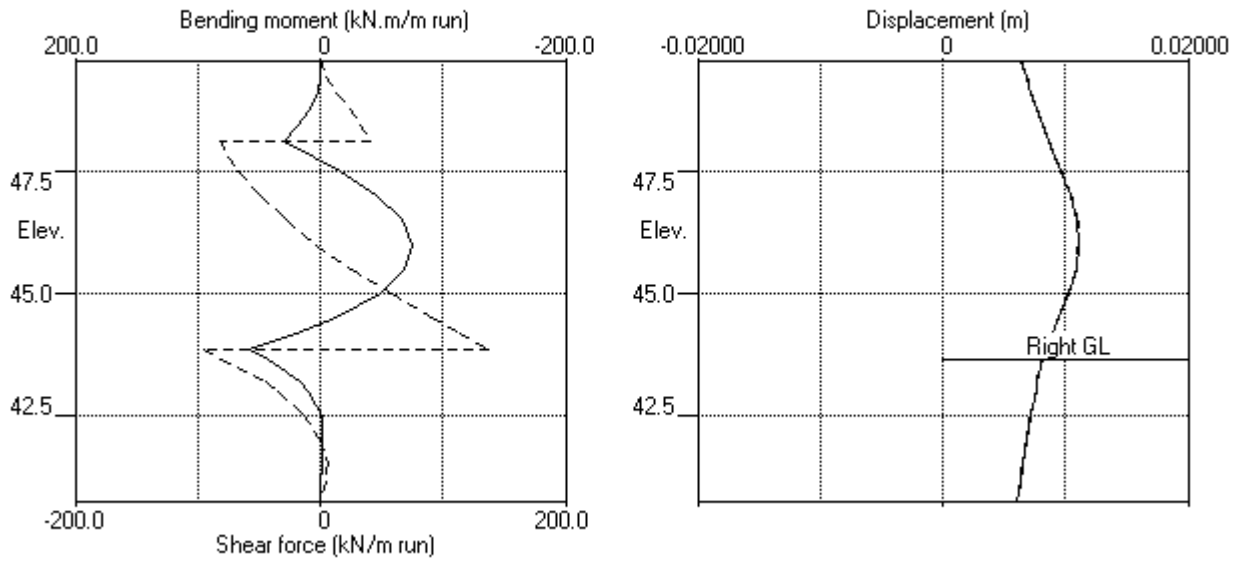

Stage No.10 Change soil type 3 to soil type 4

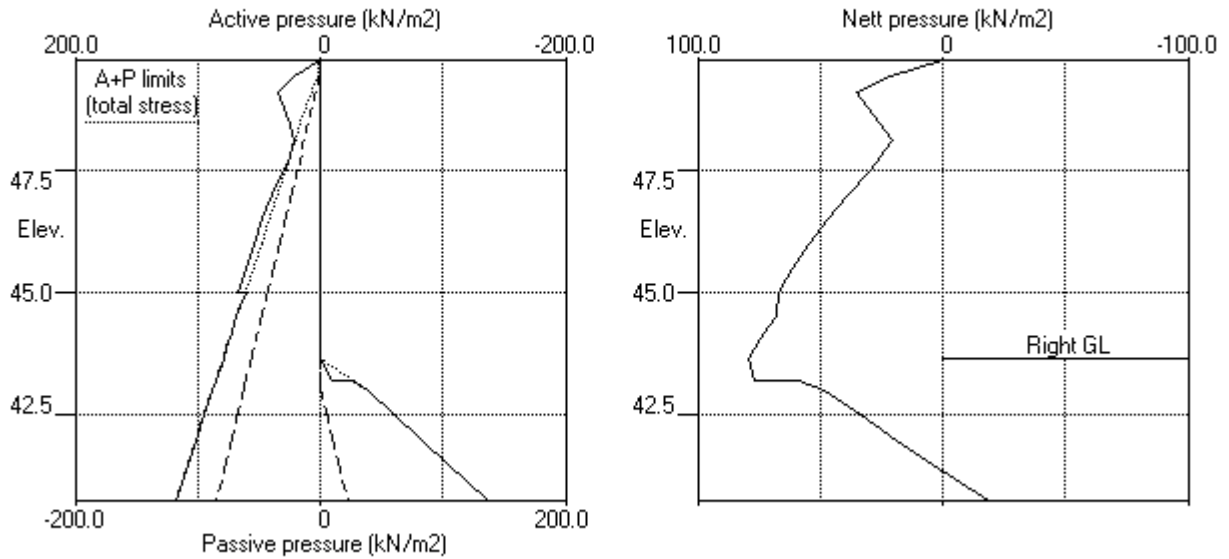

PILEDESIGNS LTD
 Program: WALLAP Version 6.06 Revision A51.B69.R54
 Licensed from GEOSOLVE
 Data filename/Run ID: Hampstead_Wall_5_450mm_rev_01_ULS1
 Hampstead - 24-26 Redington Gardens
 Wall 5, Secant-ULS1, 450 dia @ 650 - run 01

Sheet No.
 Job No. 21495
 Made by : DBS
 Date: 1-10-2018
 Checked :

Units: kN,m

Summary of results

BENDING MOMENT and DISPLACEMENT ANALYSIS of Fully Embedded Wall

Analysis options

Length of wall perpendicular to section = 50.00m
 Subgrade reaction model - Boussinesq Influence coefficients
 Soil deformations are elastic until the active or passive limit is reached
 Open Tension Crack analysis - No

Rigid boundaries: Left side 50.00 from wall
 Right side 50.00 from wall

Limit State: ULS DA1 Combination 1

Calculated Bending Moments and Strut Forces have been multiplied by a factor of 1.35 to obtain values for structural design.

Bending moment, shear force and displacement envelopes

Node no.	Y coord	Displacement		Bending moment				Shear force			
		max. m	min. m	Calculated kN.m/m		Factored kN.m/m		Calculated kN/m		Factored kN/m	
1	49.75	0.014	0.000	0	-0	0	-0	0	0	0	0
2	49.40	0.012	0.000	1	0	1	0	4	-1	6	-1
3	49.08	0.011	0.000	3	-0	4	-1	15	-2	20	-3
4	48.75	0.010	0.000	10	-1	13	-2	26	-2	35	-3
5	48.42	0.009	0.000	20	-2	27	-3	35	-2	48	-3
6	48.10	0.009	0.000	33	-2	44	-3	43	-93	58	-126
7	47.80	0.009	0.000	14	-2	19	-3	23	-86	31	-117
8	47.50	0.010	0.000	22	-20	29	-27	28	-78	38	-106
9	47.00	0.011	0.000	36	-55	48	-74	28	-63	38	-85
10	46.50	0.012	0.000	48	-82	65	-111	21	-44	28	-59
11	46.00	0.012	0.000	56	-98	76	-132	7	-22	9	-29
12	45.50	0.012	0.000	56	-102	76	-137	26	-8	35	-11
13	45.00	0.011	0.000	49	-93	66	-126	58	-17	78	-23
14	44.50	0.010	0.000	38	-75	52	-101	90	-22	122	-30
15	44.17	0.009	0.000	31	-59	42	-79	113	-22	153	-30
16	43.85	0.008	0.000	60	-39	81	-53	138	-96	186	-129
17	43.65	0.008	0.000	43	-26	58	-35	71	-80	95	-108
18	43.20	0.008	0.000	19	0	26	0	85	-45	115	-61
19	43.00	0.008	0.000	29	0	40	0	63	-34	85	-46
20	42.50	0.007	0.000	42	-1	56	-2	10	-14	13	-18
21	42.00	0.007	0.000	39	-1	53	-1	0	-30	0	-40
22	41.50	0.007	0.000	20	-1	27	-1	5	-37	7	-50
23	41.13	0.006	0.000	7	-0	9	-0	5	-26	6	-36
24	40.75	0.006	0.000	0	-0	0	-0	0	0	0	0

Summary of results (continued)

Calculated Bending Moments and Strut Forces have been multiplied by a factor of 1.35 to obtain values for structural design.

Maximum and minimum bending moment and shear force at each stage

Stage no.	Bending moment				Shear force						
	Calculated		Factored		Calculated		Factored				
min.	max. elev.	min. elev.	max. elev.	max. elev.	min. elev.	max. elev.	min. elev.	max. elev.			
	kN.m/m	kN.m/m	kN.m/m	kN/m	kN/m	kN/m	kN/m	kN/m			
1	43.65	-3	46.50	2	-4	3	45.00	-1	48.10	4	
-2	44.17	-2	48.10	5	-3	4	45.00	-2	48.75	5	
-3	56	46.00	-0	41.13	76	-0	28	47.00	-22	44.50	38
-30	No calculation at this stage										
4	48	45.50	-0	40.75	65	-0	23	47.00	-18	44.17	31
-25	40	42.50	-101	45.50	54	-136	83	43.20	-93	48.10	112
-125	41	42.50	-102	45.50	56	-137	85	43.20	-93	48.10	115
-126	No calculation at this stage										
8	42	42.50	-91	45.50	56	-123	69	43.20	-88	48.10	93
-119	60	43.85	-74	46.00	81	-100	138	43.85	-96	43.85	186
-129	No calculation at this stage										
11	40	43.85	-80	46.00	54	-107	130	43.85	-85	48.10	176
-114											

Maximum and minimum displacement at each stage

Stage no.	Displacement				Stage description
	maximum elev.	minimum elev.	maximum elev.	minimum elev.	
	m	m	m	m	
1	0.001	47.80	0.000	49.75	Apply surcharge no.1 at elev. 49.75
2	0.001	49.75	0.000	49.75	Apply water pressure profile no.1
3	0.014	49.75	0.000	49.75	Excav. to elev. 47.80 on RIGHT side
4	No calculation at this stage				Install strut no.1 at elev. 48.10
5	0.013	49.75	0.000	49.75	Apply water pressure profile no.2
6	0.011	46.00	0.000	49.75	Excav. to elev. 43.20 on RIGHT side
7	0.011	46.00	0.000	49.75	Fill to elev. 43.65 on RIGHT side
8	No calculation at this stage				Install strut no.2 at elev. 43.85
9	0.012	46.00	0.000	49.75	Change EI of wall to 43355kN.m ² /m run
10	0.011	46.00	0.000	49.75	Change soil type 3 to soil type 4
11	No calculation at this stage				Apply surcharge no.2 at elev. 43.65
12	0.011	46.00	0.000	49.75	Apply water pressure profile no.3

Strut forces at each stage (horizontal components)

Stage no.	Strut no. 1			Strut no. 2		
	at elev. 48.10			at elev. 43.85		
	Calculated	Factored	Calculated	Factored	Calculated	Factored
	kN per m run	kN per strut	kN per strut	kN per m run	kN per strut	kN per strut
5	7	7	10	---	---	---
6	135	135	182	---	---	---
7	135	135	182	---	---	---
9	131	131	177	21	21	28
10	123	123	166	233	233	315
12	126	126	170	183	183	247

Units: kN,m

Bending moment, shear force, displacement envelopes

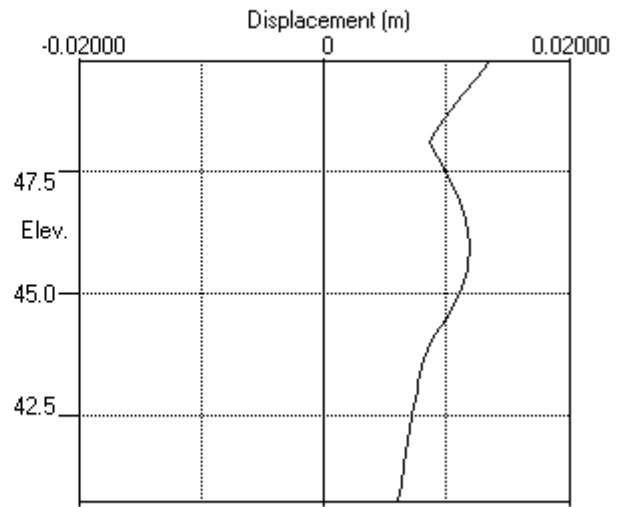
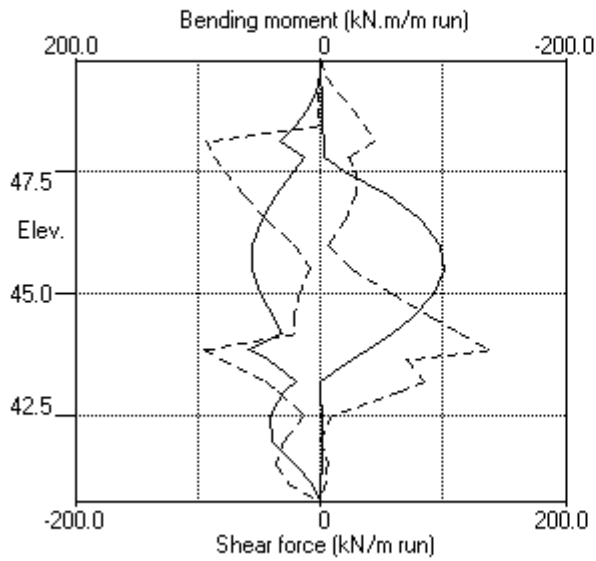



WALLAP

5-ULS2

PILEDESIGNS LTD
 Program: WALLAP Version 6.06 Revision A51.B69.R54
 Licensed from GEOSOLVE
 Data filename/Run ID: Hampstead_Wall_5_450mm_rev_01_ULS2
 Hampstead - 24-26 Redington Gardens
 Wall 5, Secant-ULS2, 450 dia @ 650 - run 01

Sheet No.
 Job No. 21495
 Made by : DBS
 Date: 1-10-2018
 Checked :

Units: kN,m

INPUT DATA

SOIL PROFILE

Stratum no.	Elevation of top of stratum	Soil types	
		Left side	Right side
1	49.75	1 Made Ground dr	1 Made Ground dr
2	47.50	2 Claygate Clay dr	2 Claygate Clay dr
3	45.00	3 London Clay und	3 London Clay und

SOIL PROPERTIES (Unfactored SLS soil strengths)

No. Description	Bulk density kN/m3	Young's Modulus Eh, kN/m2	At rest coeff. Ko	Consol state. NC/OC	Active limit Ka	Passive limit Kp	Cohesion kN/m2
(Datum elev.)		(dEh/dy)	(dKo/dy)	(Nu)	(Kac)	(Kpc)	(dc/dy)
1 Made Ground dr	18.00	10000	0.530	OC (0.250)	0.337 (0.000)	3.442 (0.000)	
2 Claygate Clay dr	19.00	30000	1.000	NC (0.200)	0.323 (1.330)	3.647 (5.195)	0.0d
3 London Cl.. (45.00)	20.00	40000 (4000)	1.000	OC (0.490)	1.000 (2.476)	1.000 (2.390)	50.00u (5.000)
4 London Cl.. (45.00)	20.00	30800 (3080)	1.000	OC (0.200)	0.351 (1.391)	3.253 (4.831)	0.0d

Additional soil parameters associated with Ka and Kp

No. Description	--- parameters for Ka ---			--- parameters for Kp ---		
	Soil friction angle	Wall adhesion coeff.	Back-fill angle	Soil friction angle	Wall adhesion coeff.	Back-fill angle
1 Made Ground dr	26.00	0.670	0.00	26.00	0.500	0.00
2 Claygate Clay dr	27.00	0.670	0.00	27.00	0.500	0.00
3 London Clay und	0.00	0.670	0.00	0.00	0.500	0.00
4 London Clay dr	25.00	0.670	0.00	25.00	0.500	0.00

GROUND WATER CONDITIONS

Density of water = 9.810 kN/m3

	Left side	Right side
Initial water table elevation	49.40	49.40

Automatic water pressure balancing at toe of wall : No

Water profile no.	Left side			Right side			
	Point no.	Elev. m	Piezo elev. m	Point no.	Elev. m	Piezo elev. m	Water press. kN/m2
1	1	49.40	49.40	1	47.50	47.50	0.0 MC+WC
2	1	49.40	49.40	1	43.00	43.00	0.0 MC+WC
3	1	49.40	49.40	1	43.65	43.65	0.0 MC+WC
				2	43.65	49.40	56.4

WALL PROPERTIES

Type of structure = Fully Embedded Wall
 Elevation of toe of wall = 40.75
 Maximum finite element length = 0.50 m
 Youngs modulus of wall E = 1.9600E+07 kN/m2
 Moment of inertia of wall I = 3.0968E-03 m4/m run
 E.I = 60696 kN.m2/m run
 Yield Moment of wall = Not defined

STRUTS and ANCHORS

Strut/ anchor no.	Elev.	Strut spacing m	X-section area of strut sq.m	Youngs modulus kN/m ²	Free length m	Inclin -ation (degs)	Pre- stress /strut kN	Tension allowed
1	48.10	1.00	0.400000	1.400E+07	5.00	0.00	0	No
2	43.85	1.00	0.300000	1.400E+07	5.00	0.00	0	No

SURCHARGE LOADS

Surch -arge no.	Elev.	Distance from wall	Length parallel to wall	Width perpend. to wall	Surcharge ----- Near edge	Surcharge ----- Far edge	Equiv. soil type	Partial factor/ Category
1	49.75	0.50(L)	10.00	10.00	10.00	=	N/A	1.30 Var
2	43.65	-0.00(R)	10.00	10.00	57.00	=	N/A	1.00 P/F

Note: L = Left side, R = Right side

Limit State Categories P/U = Permanent Unfavourable

P/F = Permanent Favourable

Var = Variable (unfavourable)

CONSTRUCTION STAGES

Construction stage no.	Stage description
1	Apply surcharge no.1 at elevation 49.75
2	Apply water pressure profile no.1 (Worst Cred.)
3	Excavate to elevation 47.80 on RIGHT side
4	Install strut or anchor no.1 at elevation 48.10
5	Apply water pressure profile no.2 (Worst Cred.)
6	Excavate to elevation 43.20 on RIGHT side
7	Fill to elevation 43.65 on RIGHT side with soil type 1
8	Install strut or anchor no.2 at elevation 43.85
9	Change EI of wall to 43355 kN.m ² /m run Yield moment not defined Allow wall to relax with new modulus value
10	Change properties of soil type 3 to soil type 4 Ko pressures will not be reset
11	Apply surcharge no.2 at elevation 43.65 No analysis at this stage
12	Apply water pressure profile no.3 (Worst Cred.)

FACTORS OF SAFETY and ANALYSIS OPTIONS

Limit State options: ULS DA1 Combination 2

Water pressures : Worst Credible

Partial factor on C' = 1.250

Partial factor on Phi' = 1.250

Partial factor on Cu = 1.400

Partial factor on Soil Modulus = 1.000

Partial factor on Permanent Unfavourable loads = 1.000

Partial factor on Permanent Favourable loads = 1.000

Partial factor on Variable Unfavourable loads = 1.300

Stability analysis:

Method of analysis - Strength Factor method

Overall factor on soil strength for calculating wall depth = 1.00

Parameters for undrained strata:

Minimum equivalent fluid density = 5.00 kN/m³

Maximum depth of water filled tension crack = 0.00 m

Bending moment and displacement calculation:

Method - Subgrade reaction model using Influence Coefficients

Open Tension Crack analysis? - No

Non-linear Modulus Parameter (L) = 9.000 m

Boundary conditions:

Length of wall (normal to plane of analysis) = 50.00 m

Width of excavation on Left side of wall = 50.00 m

Width of excavation on Right side of wall = 50.00 m

Distance to rigid boundary on Left side = 50.00 m

Distance to rigid boundary on Right side = 50.00 m

OUTPUT OPTIONS

Stage no.	Stage description	Output options		
		Displacement Bending mom. Shear force	Active, Passive pressures	Graph. output
1	Apply surcharge no.1 at elev. 49.75	No	No	No
2	Apply water pressure profile no.1	Yes	Yes	Yes
3	Excav. to elev. 47.80 on RIGHT side	Yes	Yes	Yes
4	Install strut no.1 at elev. 48.10	Yes	Yes	Yes
5	Apply water pressure profile no.2	Yes	Yes	Yes
6	Excav. to elev. 43.20 on RIGHT side	Yes	Yes	Yes
7	Fill to elev. 43.65 on RIGHT side	Yes	Yes	Yes
8	Install strut no.2 at elev. 43.85	Yes	Yes	Yes
9	Change EI of wall to 43355kN.m ² /m run	No	No	No
10	Change soil type 3 to soil type 4	No	No	No
11	Apply surcharge no.2 at elev. 43.65	No	No	No
12	Apply water pressure profile no.3	No	No	No
*	Summary output	Yes	-	Yes

Program WALLAP - Copyright (C) 2017 by DL Borin, distributed by GEOSOLVE
 150 St. Alphonsus Road, London SW4 7BW, UK www.geosolve.co.uk

Units: kN,m

Stage No.12 Apply water pressure profile no.3 (Worst Cred.)

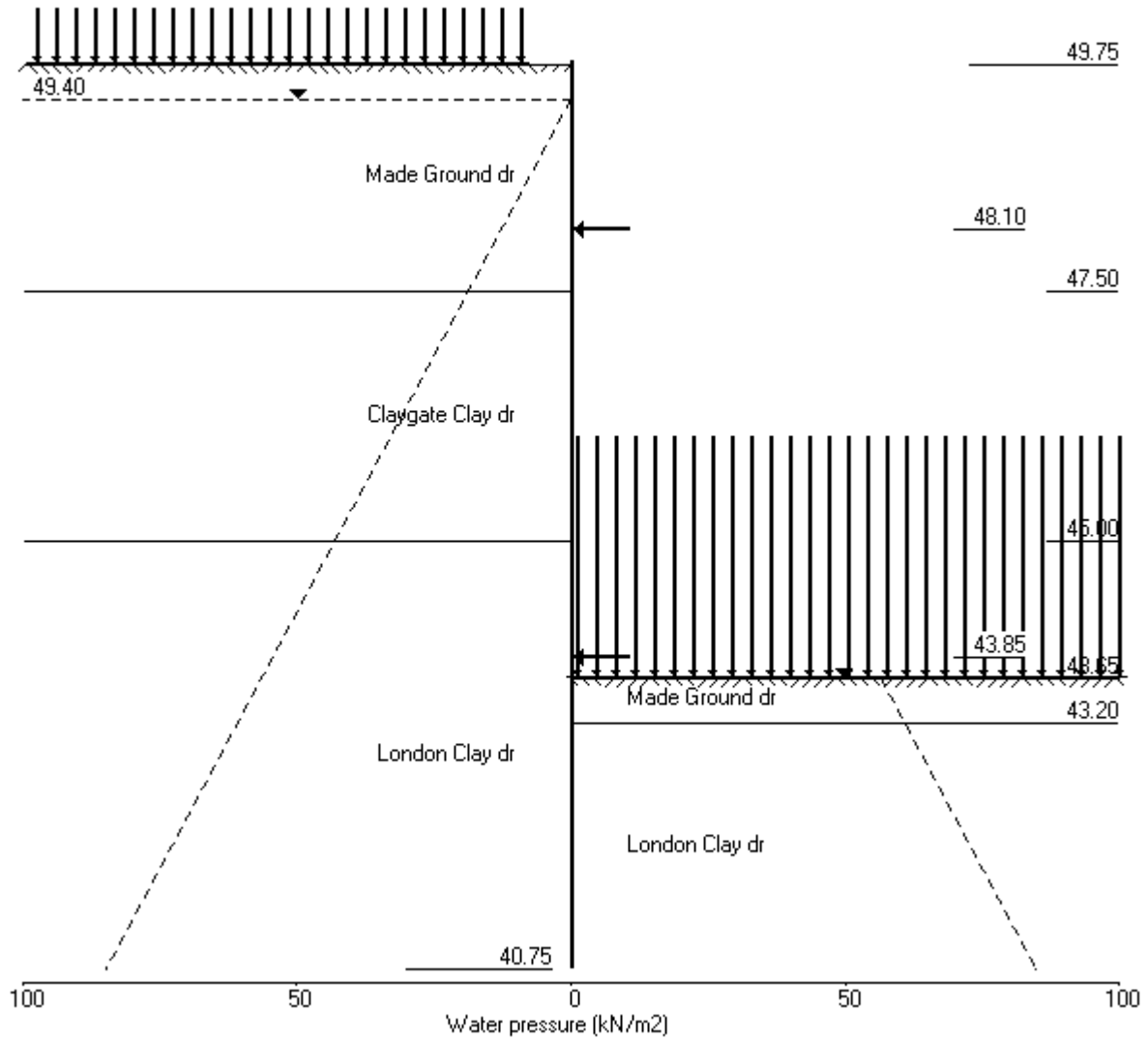

PILEDESIGNS LTD
 Program: WALLAP Version 6.06 Revision A51.B69.R54
 Licensed from GEOSOLVE
 Data filename/Run ID: Hampstead_Wall_5_450mm_rev_01_ULS2
 Hampstead - 24-26 Redington Gardens
 Wall 5, Secant-ULS2, 450 dia @ 650 - run 01

Sheet No.
 Job No. 21495
 Made by : DBS
 Date: 1-10-2018
 Checked :

Units: kN,m

Stage No. 3 Excavate to elevation 47.80 on RIGHT side

STABILITY ANALYSIS of Fully Embedded Wall according to Strength Factor method
 Factor of safety on soil strength

			Overall		Toe elev. for			
			FoS for toe		FoS = 1.000			
			elev. = 40.75					

Stage No.	--- G.L. Act.	--- Pass.	Strut Elev.	Factor of Safety	Moment of equil. at elev.	Toe elev.	Wall Penetr-ation	Direction of failure
3	49.75	47.80	Cant.	1.625	41.79	42.95	4.85	L to R

BENDING MOMENT and DISPLACEMENT ANALYSIS of Fully Embedded Wall

Analysis options

Length of wall perpendicular to section = 50.00m

Subgrade reaction model - Boussinesq Influence coefficients

Soil deformations are elastic until the active or passive limit is reached

Open Tension Crack analysis - No

Rigid boundaries: Left side 50.00 from wall
 Right side 50.00 from wall

Limit State: ULS DA1 Combination 2

Node no.	Y coord	Nett pressure kN/m2	Wall disp. m	Wall rotation rad.	Shear force kN/m	Bending moment kN.m/m	Strut forces kN/m	EI of wall kN.m2/m
1	49.75	0.00	0.026	5.56E-03	0.0	0.0		60696
2	49.40	3.06	0.024	5.56E-03	0.5	0.2		60696
3	49.08	8.40	0.022	5.56E-03	2.4	0.6		60696
4	48.75	13.53	0.021	5.56E-03	6.0	1.9		60696
5	48.42	18.37	0.019	5.54E-03	11.1	4.6		60696
6	48.10	23.03	0.017	5.50E-03	17.9	9.3		60696
7	47.80	27.21	0.015	5.44E-03	25.4	15.8		60696
8	47.50	16.93	0.014	5.34E-03	32.0	24.5		60696
		15.81	0.014	5.34E-03	32.0	24.5		
9	47.00	4.96	0.011	5.07E-03	37.2	41.9		60696
10	46.50	-5.98	0.009	4.64E-03	37.0	60.6		60696
11	46.00	-16.99	0.007	4.07E-03	31.2	77.8		60696
12	45.50	-28.05	0.005	3.38E-03	20.0	90.7		60696
13	45.00	-34.92	0.003	2.60E-03	4.2	97.8		60696
		-81.85	0.003	2.60E-03	4.2	97.8		
14	44.50	-40.23	0.002	1.83E-03	-26.3	89.7		60696
15	44.17	-19.82	0.002	1.38E-03	-36.1	79.0		60696
16	43.85	-4.46	0.001	9.95E-04	-40.0	66.3		60696
17	43.65	2.70	0.001	7.90E-04	-40.2	58.2		60696
18	43.20	13.34	0.001	4.25E-04	-36.6	40.4		60696
19	43.00	16.03	0.001	3.03E-04	-33.6	33.3		60696
20	42.50	18.71	0.001	9.05E-05	-24.9	18.5		60696
21	42.00	17.45	0.001	-1.98E-05	-15.9	8.3		60696
22	41.50	14.02	0.001	-6.47E-05	-8.0	2.6		60696
23	41.13	10.77	0.001	-7.42E-05	-3.4	0.5		60696
24	40.75	7.30	0.001	-7.58E-05	0.0	0.0		---

(continued)

Stage No.3 Excavate to elevation 47.80 on RIGHT side

Node no.	Y coord	LEFT side					Total earth pressure kN/m2	Coeff. of subgrade reaction kN/m3
		Water press. kN/m2	Vertic -al kN/m2	Effective Active limit kN/m2	Effective Passive limit kN/m2	Earth pressure kN/m2		
1	49.75	0.00	0.00	0.00	0.00	0.00	0.00	3315
2	49.40	0.00	7.46	3.06	19.88	3.06	3.06a	3315
3	49.08	3.19	12.71	5.22	33.87	5.22	8.40a	3315
4	48.75	6.38	17.44	7.15	46.45	7.15	13.53a	3315
5	48.42	9.56	21.48	8.81	57.21	8.81	18.37a	3315
6	48.10	12.75	25.05	10.27	66.72	10.27	23.03a	3315
7	47.80	15.70	28.07	11.51	74.78	11.51	27.21a	3315
8	47.50	18.64	30.91	12.68	82.35	12.68	31.32a	3315
		18.64	30.91	12.23	86.18	12.23	30.87a	9562
9	47.00	23.54	35.87	14.19	100.00	14.19	37.73a	9562
10	46.50	28.45	40.58	16.06	113.14	16.06	44.50a	9562
11	46.00	33.35	45.14	17.86	125.83	17.86	51.21a	9562
12	45.50	38.26	49.58	19.62	138.22	19.62	57.87a	9562
13	45.00	43.16	53.95	21.34	150.40	25.55	68.72	9562
		Total>	97.11	23.75m	182.48	41.26	41.26	18562
14	44.50	Total>	106.84	26.25m	196.47	69.40	69.40	19490
15	44.17	Total>	113.14	27.88m	205.55	84.77	84.77	20093
16	43.85	Total>	119.43	29.50m	214.62	97.93	97.93	20697
17	43.65	Total>	123.30	30.50m	220.20	105.02	105.02	21068
18	43.20	Total>	132.00	32.75m	232.74	118.57	118.57	21903
19	43.00	Total>	135.87	33.75m	238.31	123.70	123.70	22274
20	42.50	Total>	145.53	36.25m	252.25	134.76	134.76	23202
21	42.00	Total>	155.20	40.21	266.18	144.08	144.08	24130
22	41.50	Total>	164.88	45.47	280.13	152.45	152.45	25059
23	41.13	Total>	172.14	49.41	290.59	158.43	158.43	25755
24	40.75	Total>	177.06	51.01	298.71	164.33	164.33	26451

Node no.	Y coord	RIGHT side					Total earth pressure kN/m2	Coeff. of subgrade reaction kN/m3
		Water press. kN/m2	Vertic -al kN/m2	Effective Active limit kN/m2	Effective Passive limit kN/m2	Earth pressure kN/m2		
1	49.75	0.00	0.00	0.00	0.00	0.00	0.00	0.0
2	49.40	0.00	0.00	0.00	0.00	0.00	0.00	0.0
3	49.08	0.00	0.00	0.00	0.00	0.00	0.00	0.0
4	48.75	0.00	0.00	0.00	0.00	0.00	0.00	0.0
5	48.42	0.00	0.00	0.00	0.00	0.00	0.00	0.0
6	48.10	0.00	0.00	0.00	0.00	0.00	0.00	0.0
7	47.80	0.00	0.00	0.00	0.00	0.00	0.00	0.0
		0.00	0.00	0.00	0.00	0.00	0.00	4379
8	47.50	0.00	5.40	2.21	14.38	14.38	14.38p	4379
		0.00	5.40	2.14	15.05	15.05	15.05p	12656
9	47.00	4.90	10.00	3.95	27.87	27.87	32.77p	12656
10	46.50	9.81	14.59	5.77	40.68	40.68	50.49p	12656
11	46.00	14.71	19.19	7.59	53.49	53.49	68.20p	12656
12	45.50	19.62	23.78	9.41	66.30	66.30	85.92p	12656
13	45.00	24.52	28.38	11.23	79.11	79.11	103.64p	12656
		Total>	52.90	14.00m	138.26	123.11	123.11	24075
14	44.50	Total>	62.90	16.50m	152.54	109.63	109.63	25279
15	44.17	Total>	69.41	18.13m	161.81	104.59	104.59	26061
16	43.85	Total>	75.91	19.75m	171.09	102.39	102.39	26844
17	43.65	Total>	79.91	20.75m	176.80	102.32	102.32	27325
18	43.20	Total>	88.91	23.00m	189.64	105.24	105.24	28408
19	43.00	Total>	92.91	24.00m	195.35	107.68	107.68	28890

(continued)

Stage No.3 Excavate to elevation 47.80 on RIGHT side

Node no.	Y coord	Effective stresses					Total earth pressure	Coeff. of subgrade reaction
		Water press.	Vertical	Active limit	Passive limit	Earth pressure		
		kN/m2	kN/m2	kN/m2	kN/m2	kN/m2	kN/m3	
20	42.50	Total>	102.92	26.50m	209.62	116.05	116.05	30094
21	42.00	Total>	112.92	29.00m	223.90	126.63	126.63	31297
22	41.50	Total>	122.93	31.50m	238.17	138.43	138.43	32501
23	41.13	Total>	130.43	33.37m	248.88	147.66	147.66	33404
24	40.75	Total>	137.94	35.25m	259.59	157.02	157.02	34307

Note: 57.87a Soil pressure at active limit
 103.64p Soil pressure at passive limit

Units: kN,m

Stage No.3 Excav. to elev. 47.80 on RIGHT side

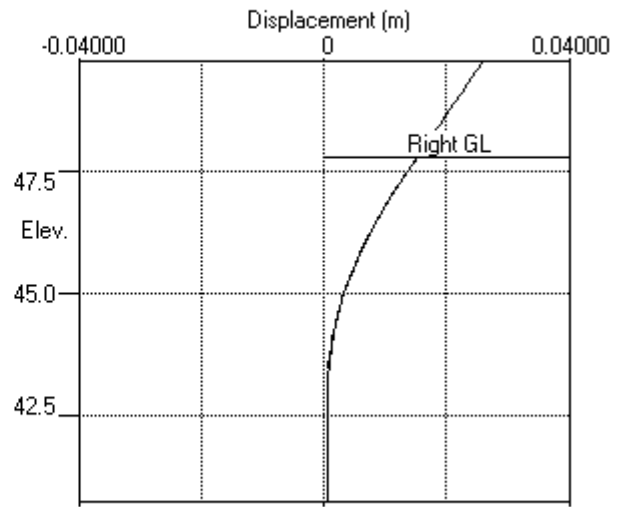
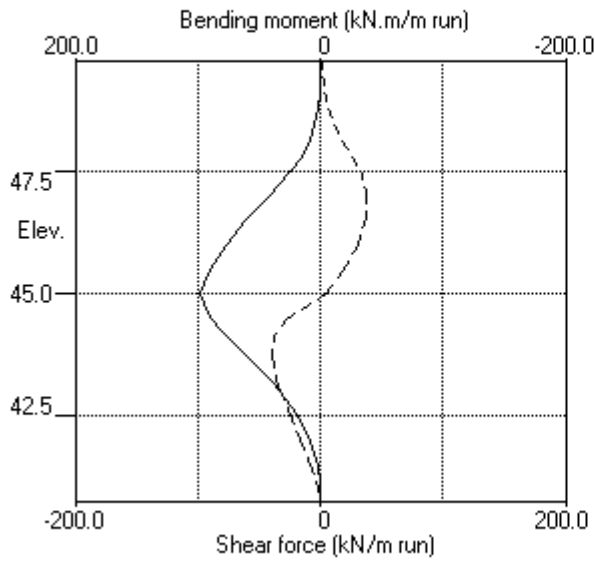

Stage No.3 Excav. to elev. 47.80 on RIGHT side

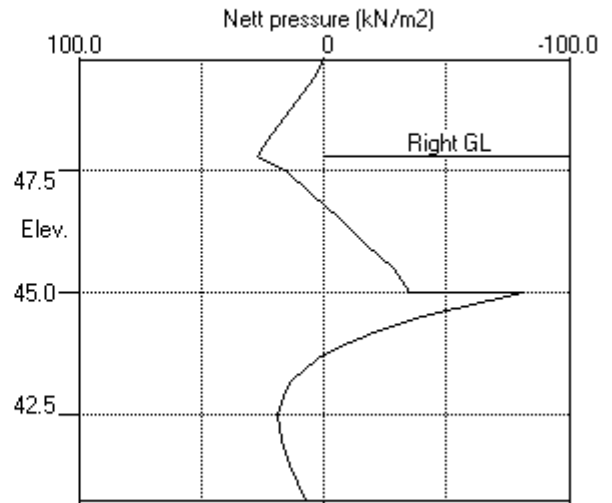
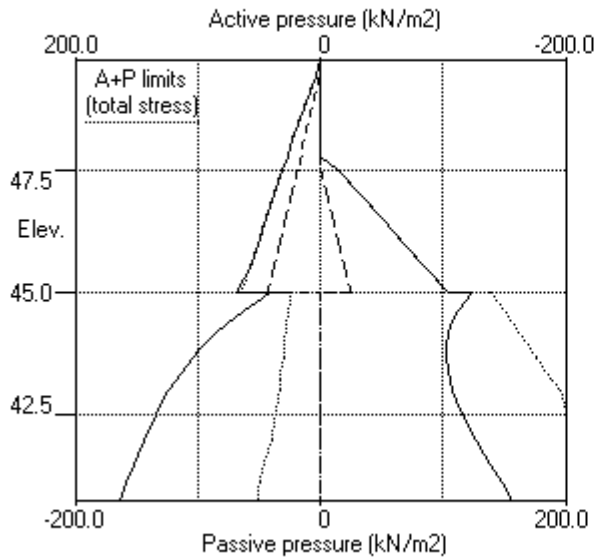

PILEDESIGNS LTD
 Program: WALLAP Version 6.06 Revision A51.B69.R54
 Licensed from GEOSOLVE
 Data filename/Run ID: Hampstead_Wall_5_450mm_rev_01_ULS2
 Hampstead - 24-26 Redington Gardens
 Wall 5, Secant-ULS2, 450 dia @ 650 - run 01

Sheet No.
 Job No. 21495
 Made by : DBS
 Date: 1-10-2018
 Checked :

Units: kN,m

Stage No. 6 Excavate to elevation 43.20 on RIGHT side

STABILITY ANALYSIS of Fully Embedded Wall according to Strength Factor method
 Factor of safety on soil strength

			Overall					
			FoS for toe		Toe elev. for			
			elev. = 40.75		FoS = 1.000			

Stage No.	--- G.L. Act.	--- Pass.	Strut Elev.	Factor of Safety	Moment of equil. at elev.	Toe elev.	Wall Penetr-ation	Direction of failure
6	49.75	43.20	48.10	1.348	n/a	42.20	1.00	L to R

BENDING MOMENT and DISPLACEMENT ANALYSIS of Fully Embedded Wall

Analysis options

Length of wall perpendicular to section = 50.00m

Subgrade reaction model - Boussinesq Influence coefficients

Soil deformations are elastic until the active or passive limit is reached

Open Tension Crack analysis - No

Rigid boundaries: Left side 50.00 from wall
 Right side 50.00 from wall

Limit State: ULS DA1 Combination 2

Node no.	Y coord	Nett pressure kN/m ²	Wall disp. m	Wall rotation rad.	Shear force kN/m	Bending moment kN.m/m	Strut forces kN/m	EI of wall kN.m ² /m
1	49.75	0.00	0.016	-9.18E-04	0.0	0.0		60696
2	49.40	19.88	0.016	-9.20E-04	3.5	0.5		60696
3	49.08	37.06	0.016	-9.29E-04	12.7	3.0		60696
4	48.75	40.44	0.016	-9.60E-04	25.3	8.7		60696
5	48.42	31.48	0.017	-1.03E-03	37.0	19.1		60696
6	48.10	23.03	0.017	-1.17E-03	45.9	32.9	148.7	60696
		23.03	0.017	-1.17E-03	-102.8	32.9		
7	47.80	27.21	0.018	-1.26E-03	-95.3	3.1		60696
8	47.50	31.32	0.018	-1.21E-03	-86.5	-24.2		60696
		30.87	0.018	-1.21E-03	-86.5	-24.2		
9	47.00	37.73	0.018	-8.50E-04	-69.4	-63.3		60696
10	46.50	44.50	0.019	-2.06E-04	-48.8	-93.1		60696
11	46.00	51.21	0.019	6.37E-04	-24.9	-111.7		60696
12	45.50	57.87	0.018	1.58E-03	2.4	-117.6		60696
13	45.00	64.51	0.017	2.51E-03	33.0	-107.9		60696
		23.75	0.017	2.51E-03	33.0	-107.9		
14	44.50	26.25	0.016	3.32E-03	45.5	-90.1		60696
15	44.17	27.88	0.014	3.76E-03	54.3	-74.3		60696
16	43.85	29.50	0.013	4.11E-03	63.6	-55.4		60696
17	43.65	30.50	0.012	4.27E-03	69.6	-42.1		60696
18	43.20	32.75	0.010	4.45E-03	83.8	-8.1		60696
		-67.97	0.010	4.45E-03	83.8	-8.1		
19	43.00	-72.68	0.009	4.46E-03	69.8	7.3		60696
20	42.50	-84.45	0.007	4.29E-03	30.5	32.4		60696
21	42.00	-71.52	0.005	3.99E-03	-8.5	41.0		60696
22	41.50	-45.29	0.003	3.71E-03	-37.7	27.6		60696
23	41.13	24.19	0.002	3.58E-03	-41.7	12.6		60696
24	40.75	198.01	0.001	3.54E-03	0.0	0.0		---
At elev. 48.10			Strut force =	148.7 kN/strut =	148.7 kN/m run			

(continued)

Stage No.6 Excavate to elevation 43.20 on RIGHT side

Node no.	Y coord	Effective stresses					Total earth pressure	Coeff. of subgrade reaction
		Water press.	Vertic -al	Active limit	Passive limit	Earth pressure		
		kN/m2	kN/m2	kN/m2	kN/m2	kN/m2	kN/m2	kN/m3
1	49.75	0.00	0.00	0.00	0.00	0.00	0.00	6488
2	49.40	0.00	7.46	3.06	19.88	19.88	19.88p	6488
3	49.08	3.19	12.71	5.22	33.87	33.87	37.06p	6488
4	48.75	6.38	17.44	7.15	46.45	34.06	40.44	6488
5	48.42	9.56	21.48	8.81	57.21	21.92	31.48	6488
6	48.10	12.75	25.05	10.27	66.72	10.27	23.03a	2306
7	47.80	15.70	28.07	11.51	74.78	11.51	27.21a	2306
8	47.50	18.64	30.91	12.68	82.35	12.68	31.32a	2306
		18.64	30.91	12.23	86.18	12.23	30.87a	6623
9	47.00	23.54	35.87	14.19	100.00	14.19	37.73a	6623
10	46.50	28.45	40.58	16.06	113.14	16.06	44.50a	6623
11	46.00	33.35	45.14	17.86	125.83	17.86	51.21a	6623
12	45.50	38.26	49.58	19.62	138.22	19.62	57.87a	6623
13	45.00	43.16	53.95	21.34	150.40	21.34	64.51a	6623
		Total>	97.11	23.75m	182.48	23.75	23.75a	13395
14	44.50	Total>	106.84	26.25m	196.47	26.25	26.25a	14065
15	44.17	Total>	113.14	27.88m	205.55	27.88	27.88a	14500
16	43.85	Total>	119.43	29.50m	214.62	29.50	29.50a	14935
17	43.65	Total>	123.30	30.50m	220.20	30.50	30.50a	15203
18	43.20	Total>	132.00	32.75m	232.74	32.75	32.75a	15806
19	43.00	Total>	135.87	33.75m	238.31	33.75	33.75a	16074
20	42.50	Total>	145.53	36.25m	252.25	36.25	36.25a	16743
21	42.00	Total>	155.20	40.21	266.18	63.45	63.45	17413
22	41.50	Total>	164.88	45.47	280.13	103.94	103.94	18083
23	41.13	Total>	172.14	49.41	290.59	134.49	134.49	18585
24	40.75	Total>	177.06	51.01	298.71	210.26	210.26	594373

Node no.	Y coord	Effective stresses					Total earth pressure	Coeff. of subgrade reaction
		Water press.	Vertic -al	Active limit	Passive limit	Earth pressure		
		kN/m2	kN/m2	kN/m2	kN/m2	kN/m2	kN/m2	kN/m3
1	49.75	0.00	0.00	0.00	0.00	0.00	0.00	0.0
2	49.40	0.00	0.00	0.00	0.00	0.00	0.00	0.0
3	49.08	0.00	0.00	0.00	0.00	0.00	0.00	0.0
4	48.75	0.00	0.00	0.00	0.00	0.00	0.00	0.0
5	48.42	0.00	0.00	0.00	0.00	0.00	0.00	0.0
6	48.10	0.00	0.00	0.00	0.00	0.00	0.00	0.0
7	47.80	0.00	0.00	0.00	0.00	0.00	0.00	0.0
8	47.50	0.00	0.00	0.00	0.00	0.00	0.00	0.0
9	47.00	0.00	0.00	0.00	0.00	0.00	0.00	0.0
10	46.50	0.00	0.00	0.00	0.00	0.00	0.00	0.0
11	46.00	0.00	0.00	0.00	0.00	0.00	0.00	0.0
12	45.50	0.00	0.00	0.00	0.00	0.00	0.00	0.0
13	45.00	0.00	0.00	0.00	0.00	0.00	0.00	0.0
14	44.50	0.00	0.00	0.00	0.00	0.00	0.00	0.0
15	44.17	0.00	0.00	0.00	0.00	0.00	0.00	0.0
16	43.85	0.00	0.00	0.00	0.00	0.00	0.00	0.0
17	43.65	0.00	0.00	0.00	0.00	0.00	0.00	0.0
18	43.20	0.00	0.00	0.00	0.00	0.00	0.00	0.0
		Total>	0.00	0.00	100.72	100.72	100.72p	33055
19	43.00	Total>	4.00	1.00m	106.43	106.43	106.43p	33616
20	42.50	Total>	14.00	3.50m	120.70	120.70	120.70p	35016
21	42.00	Total>	24.00	6.00m	134.97	134.97	134.97p	36417

(continued)

Stage No.6 Excavate to elevation 43.20 on RIGHT side

Node no.	Y coord	----- Effective stresses -----					Total earth pressure	Coeff. of subgrade reaction
		Water press. kN/m2	Vertic -al kN/m2	Active limit kN/m2	Passive limit kN/m2	Earth pressure kN/m2		
22	41.50	Total>	34.00	8.50m	149.24	149.24	149.24p	37818
23	41.13	Total>	41.50	10.38m	159.94	110.30	110.30	38868
24	40.75	Total>	49.01	12.25m	170.64	12.25	12.25a	989842

Note: 12.25a Soil pressure at active limit
 149.24p Soil pressure at passive limit

Units: kN,m

Stage No.6 Excav. to elev. 43.20 on RIGHT side

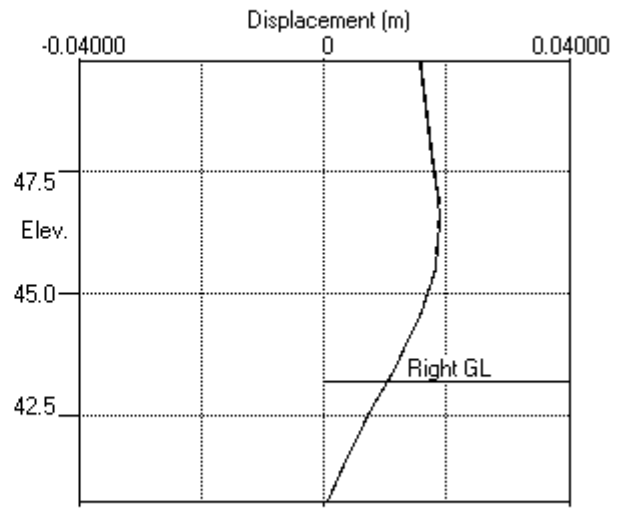
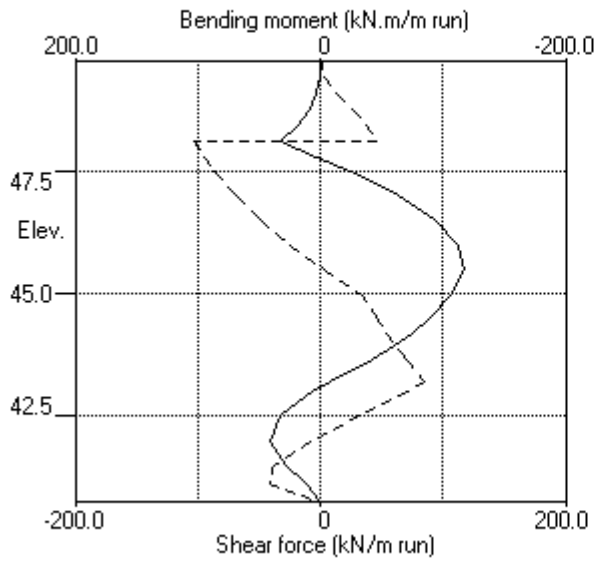

Stage No.6 Excav. to elev. 43.20 on RIGHT side

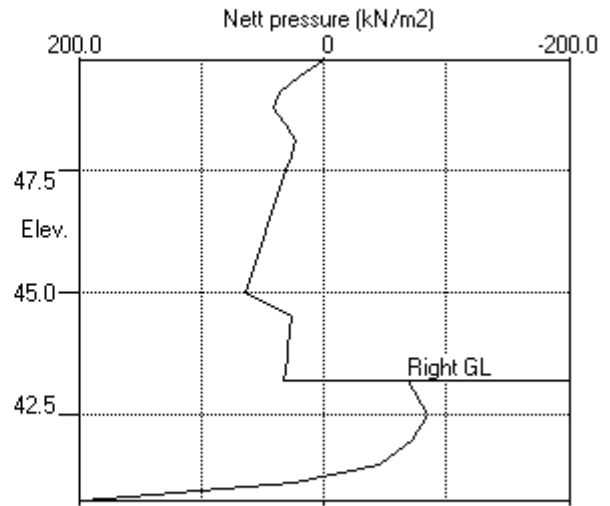
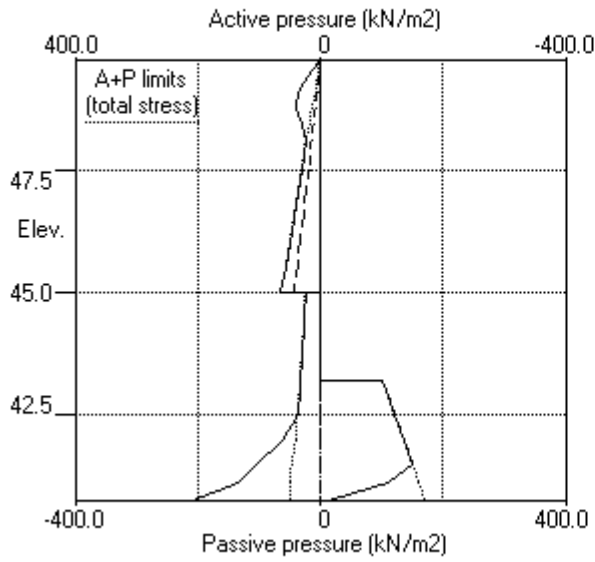

PILEDESIGNS LTD
 Program: WALLAP Version 6.06 Revision A51.B69.R54
 Licensed from GEOSOLVE
 Data filename/Run ID: Hampstead_Wall_5_450mm_rev_01_ULS2
 Hampstead - 24-26 Redington Gardens
 Wall 5, Secant-ULS2, 450 dia @ 650 - run 01

Sheet No.
 Job No. 21495
 Made by : DBS
 Date: 1-10-2018
 Checked :

Units: kN,m

Stage No. 7 Fill to elevation 43.65 on RIGHT side with soil type 1

STABILITY ANALYSIS of Fully Embedded Wall according to Strength Factor method
 Factor of safety on soil strength

			Overall		Toe elev. for			
			FoS for toe		FoS = 1.000			
			elev. = 40.75					
Stage	--- G.L. ---	Strut	Factor	Moment	Toe	Wall	Direction	
No.	Act. Pass.	Elev.	of	equilib.	elev.	Penetr	of	
			Safety	at elev.		-ation	failure	
7	49.75 43.65	48.10	1.411	n/a	42.31	1.34	L to R	

BENDING MOMENT and DISPLACEMENT ANALYSIS of Fully Embedded Wall

Analysis options

Length of wall perpendicular to section = 50.00m

Subgrade reaction model - Boussinesq Influence coefficients

Soil deformations are elastic until the active or passive limit is reached

Open Tension Crack analysis - No

Rigid boundaries: Left side 50.00 from wall
 Right side 50.00 from wall

Limit State: ULS DA1 Combination 2

Node no.	Y coord	Nett pressure kN/m ²	Wall disp. m	Wall rotation rad.	Shear force kN/m	Bending moment kN.m/m	Strut forces kN/m	EI of wall kN.m ² /m
1	49.75	0.00	0.016	-9.16E-04	0.0	0.0		60696
2	49.40	19.86	0.016	-9.18E-04	3.5	0.5		60696
3	49.08	37.04	0.016	-9.27E-04	12.7	3.0		60696
4	48.75	40.43	0.016	-9.58E-04	25.3	8.7		60696
5	48.42	31.47	0.017	-1.03E-03	37.0	19.1		60696
6	48.10	23.03	0.017	-1.17E-03	45.9	32.9	149.1	60696
		23.03	0.017	-1.17E-03	-103.2	32.9		
7	47.80	27.21	0.018	-1.26E-03	-95.7	3.0		60696
8	47.50	31.32	0.018	-1.20E-03	-86.9	-24.4		60696
		30.88	0.018	-1.20E-03	-86.9	-24.4		
9	47.00	37.77	0.018	-8.44E-04	-69.7	-63.8		60696
10	46.50	44.57	0.019	-1.95E-04	-49.2	-93.7		60696
11	46.00	51.34	0.019	6.53E-04	-25.2	-112.5		60696
12	45.50	58.09	0.018	1.60E-03	2.2	-118.5		60696
13	45.00	64.84	0.017	2.54E-03	32.9	-108.8		60696
		24.39	0.017	2.54E-03	32.9	-108.8		
14	44.50	27.24	0.016	3.36E-03	45.8	-91.0		60696
15	44.17	29.14	0.014	3.80E-03	55.0	-75.1		60696
16	43.85	31.08	0.013	4.16E-03	64.8	-55.9		60696
17	43.65	32.29	0.012	4.32E-03	71.1	-42.4		60696
18	43.20	31.72	0.010	4.50E-03	85.5	-7.6		60696
		-71.17	0.010	4.50E-03	85.5	-7.6		
19	43.00	-75.42	0.009	4.50E-03	70.8	8.1		60696
20	42.50	-86.10	0.007	4.33E-03	30.5	33.4		60696
21	42.00	-72.17	0.005	4.02E-03	-9.1	41.7		60696
22	41.50	-45.03	0.003	3.73E-03	-38.4	28.0		60696
23	41.13	25.12	0.002	3.61E-03	-42.1	12.7		60696
24	40.75	199.63	0.000	3.57E-03	0.0	0.0		---

At elev. 48.10 Strut force = 149.1 kN/strut = 149.1 kN/m run

(continued)

Stage No.7 Fill to elevation 43.65 on RIGHT side with soil type 1

Node no.	Y coord	----- LEFT side -----					Total earth pressure kN/m2	Coeff. of subgrade reaction kN/m3
		Water press. kN/m2	Vertic -al kN/m2	Effective Active limit kN/m2	Effective Passive limit kN/m2	Earth pressure kN/m2		
1	49.75	0.00	0.00	0.00	0.00	0.00	6035	
2	49.40	0.00	7.46	3.06	19.88	19.86	6035	
3	49.08	3.19	12.71	5.22	33.87	33.85	6035	
4	48.75	6.38	17.44	7.15	46.45	34.05	6035	
5	48.42	9.56	21.48	8.81	57.21	21.91	6035	
6	48.10	12.75	25.05	10.27	66.72	10.27	6035	
7	47.80	15.70	28.07	11.51	74.78	11.52	2963	
8	47.50	18.64	30.91	12.68	82.35	12.68	2963	
		18.64	30.91	12.23	86.18	12.24	8536	
9	47.00	23.54	35.87	14.19	100.00	14.22	8536	
10	46.50	28.45	40.58	16.06	113.14	16.12	8536	
11	46.00	33.35	45.14	17.86	125.83	17.98	8536	
12	45.50	38.26	49.58	19.62	138.22	19.83	8536	
13	45.00	43.16	53.95	21.34	150.40	21.67	8536	
		Total>	97.11	23.75m	182.48	24.39	16744	
14	44.50	Total>	106.84	26.25m	196.47	27.24	17581	
15	44.17	Total>	113.14	27.88m	205.55	29.14	18125	
16	43.85	Total>	119.43	29.50m	214.62	31.08	18669	
17	43.65	Total>	123.30	30.50m	220.20	32.29	19004	
18	43.20	Total>	132.00	32.75m	232.74	35.04	19757	
19	43.00	Total>	135.87	33.75m	238.31	36.27	20092	
20	42.50	Total>	145.53	36.25m	252.25	39.31	20930	
21	42.00	Total>	155.20	40.21	266.18	67.01	21767	
22	41.50	Total>	164.88	45.47	280.13	107.97	22604	
23	41.13	Total>	172.14	49.41	290.59	138.85	23232	
24	40.75	Total>	177.06	51.01	298.71	214.96	23860	

Node no.	Y coord	----- RIGHT side -----					Total earth pressure kN/m2	Coeff. of subgrade reaction kN/m3
		Water press. kN/m2	Vertic -al kN/m2	Effective Active limit kN/m2	Effective Passive limit kN/m2	Earth pressure kN/m2		
1	49.75	0.00	0.00	0.00	0.00	0.00	0.0	
2	49.40	0.00	0.00	0.00	0.00	0.00	0.0	
3	49.08	0.00	0.00	0.00	0.00	0.00	0.0	
4	48.75	0.00	0.00	0.00	0.00	0.00	0.0	
5	48.42	0.00	0.00	0.00	0.00	0.00	0.0	
6	48.10	0.00	0.00	0.00	0.00	0.00	0.0	
7	47.80	0.00	0.00	0.00	0.00	0.00	0.0	
8	47.50	0.00	0.00	0.00	0.00	0.00	0.0	
9	47.00	0.00	0.00	0.00	0.00	0.00	0.0	
10	46.50	0.00	0.00	0.00	0.00	0.00	0.0	
11	46.00	0.00	0.00	0.00	0.00	0.00	0.0	
12	45.50	0.00	0.00	0.00	0.00	0.00	0.0	
13	45.00	0.00	0.00	0.00	0.00	0.00	0.0	
14	44.50	0.00	0.00	0.00	0.00	0.00	0.0	
15	44.17	0.00	0.00	0.00	0.00	0.00	0.0	
16	43.85	0.00	0.00	0.00	0.00	0.00	0.0	
17	43.65	0.00	0.00	0.00	0.00	0.00	0.0	
		0.00	0.00	0.00	0.00	0.00	2963	
18	43.20	0.00	8.10	3.32	21.58	3.32	2963	
		Total>	8.10	2.25m	108.82	106.21	19757	
19	43.00	Total>	12.10	3.25m	114.53	111.69	20092	
20	42.50	Total>	22.10	5.75m	128.80	125.42	20930	

(continued)

Stage No.7 Fill to elevation 43.65 on RIGHT side with soil type 1

Node no.	Y coord	----- RIGHT side -----					Total earth pressure	Coeff. of subgrade reaction
		Water press. kN/m2	Vertic -al kN/m2	Effective Active limit kN/m2	Effective Passive limit kN/m2	Earth pressure kN/m2		
21	42.00	Total>	32.10	8.25m	143.07	139.19	139.19	21767
22	41.50	Total>	42.10	10.75m	157.34	153.00	153.00	22604
23	41.13	Total>	49.61	12.63m	168.04	113.72	113.72	23232
24	40.75	Total>	57.11	14.50m	178.75	15.33	15.33	23860

Note: 3.32a Soil pressure at active limit
 123.45p Soil pressure at passive limit

Units: kN,m

Stage No.7 Fill to elev. 43.65 on RIGHT side

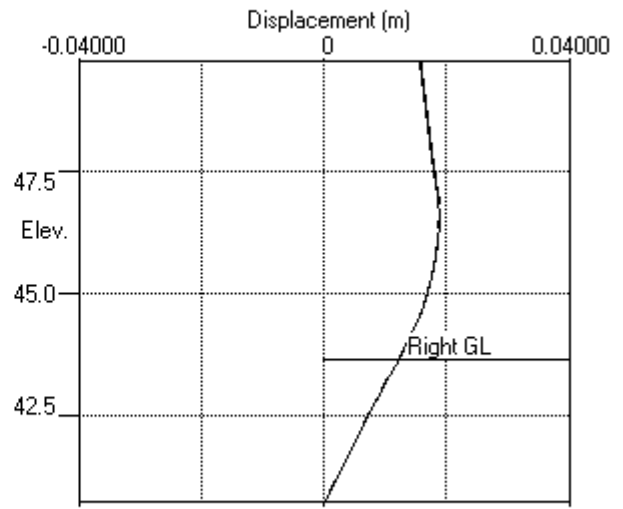
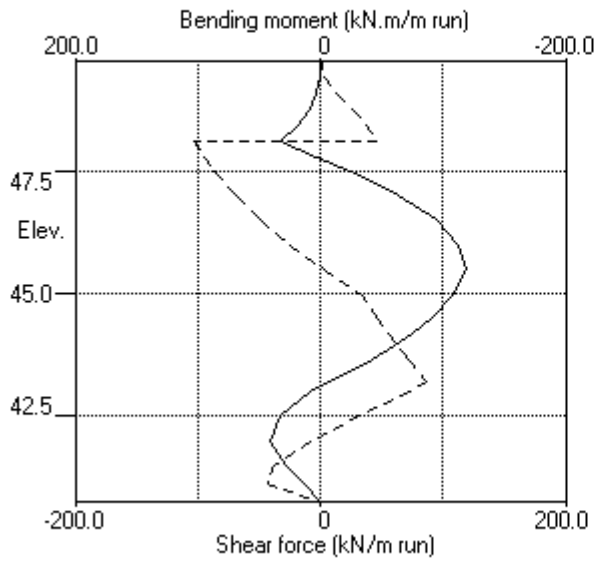

Stage No.7 Fill to elev. 43.65 on RIGHT side

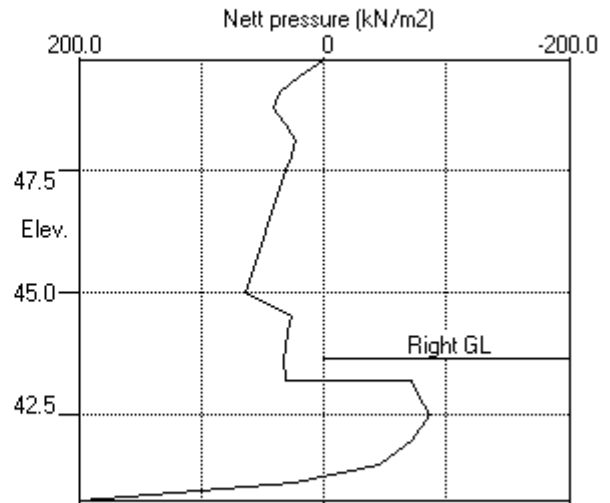
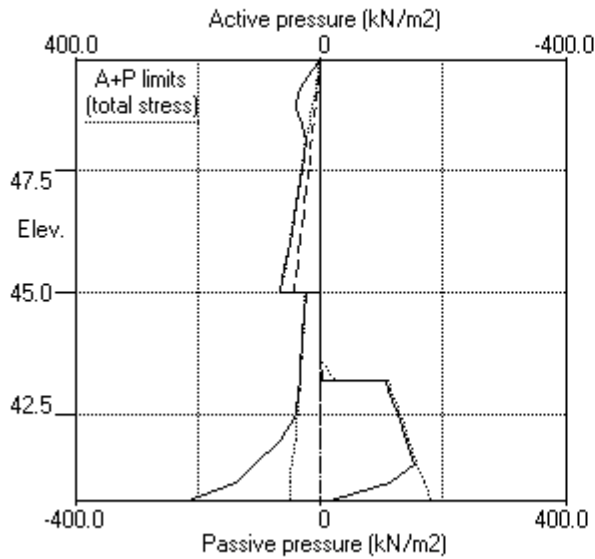

Units: kN,m

Stage No. 9 Change EI of wall to 43355 kN.m²/m run
 Yield moment not defined
 Allow wall to relax with new modulus value

STABILITY ANALYSIS of Fully Embedded Wall according to Strength Factor method
 Factor of safety on soil strength

			Overall				
			FoS for toe		Toe elev. for		
			elev. = 40.75		FoS = 1.000		
			-----		-----		
Stage	--- G.L. ---	Strut	Factor	Moment	Toe	Wall	Direction
No.	Act. Pass.	Elev.	of	of	elev.	Penetr	of
			Safety	at elev.		-ation	failure
9	49.75 43.65		More than one strut.		No FoS calc.		

BENDING MOMENT and DISPLACEMENT ANALYSIS of Fully Embedded Wall

Analysis options

Length of wall perpendicular to section = 50.00m

Subgrade reaction model - Boussinesq Influence coefficients

Soil deformations are elastic until the active or passive limit is reached

Open Tension Crack analysis - No

Rigid boundaries: Left side 50.00 from wall
 Right side 50.00 from wall

Limit State: ULS DA1 Combination 2

Node no.	Y coord	Nett pressure kN/m ²	Wall disp. m	Wall rotation rad.	Shear force kN/m	Bending moment kN.m/m	Strut forces kN/m	EI of wall kN.m ² /m
1	49.75	0.00	0.015	-1.21E-03	0.0	0.0		43355
2	49.40	19.88	0.015	-1.21E-03	3.5	0.5		43355
3	49.08	37.06	0.016	-1.23E-03	12.7	3.0		43355
4	48.75	41.87	0.016	-1.27E-03	25.6	8.7		43355
5	48.42	32.25	0.017	-1.38E-03	37.6	19.2		43355
6	48.10	23.06	0.017	-1.57E-03	46.6	33.2	143.4	43355
		23.06	0.017	-1.57E-03	-96.9	33.2		
7	47.80	27.21	0.018	-1.71E-03	-89.3	4.8		43355
8	47.50	31.32	0.018	-1.65E-03	-80.5	-21.1		43355
		30.87	0.018	-1.65E-03	-80.5	-21.1		
9	47.00	37.73	0.019	-1.21E-03	-63.4	-58.0		43355
10	46.50	44.50	0.019	-4.13E-04	-42.8	-85.5		43355
11	46.00	51.21	0.019	6.35E-04	-18.9	-101.8		43355
12	45.50	57.87	0.019	1.79E-03	8.4	-105.4		43355
13	45.00	64.51	0.017	2.89E-03	39.0	-93.4		43355
		23.75	0.017	2.89E-03	39.0	-93.4		
14	44.50	26.25	0.016	3.79E-03	51.5	-73.3		43355
15	44.17	27.88	0.015	4.24E-03	60.3	-55.9		43355
16	43.85	30.52	0.013	4.54E-03	69.8	-35.4	24.8	43355
		30.52	0.013	4.54E-03	44.9	-35.4		
17	43.65	33.26	0.012	4.65E-03	51.3	-25.0		43355
18	43.20	35.74	0.010	4.72E-03	66.8	2.9		43355
		-63.12	0.010	4.72E-03	66.8	2.9		
19	43.00	-65.33	0.009	4.67E-03	54.0	15.8		43355
20	42.50	-73.14	0.007	4.36E-03	19.4	35.5		43355
21	42.00	-59.83	0.005	3.91E-03	-13.9	40.8		43355
22	41.50	-36.64	0.003	3.53E-03	-38.0	26.4		43355
23	41.13	28.96	0.002	3.37E-03	-39.4	11.7		43355
24	40.75	181.44	0.000	3.32E-03	0.0	0.0		---

At elev. 48.10 Strut force = 143.4 kN/strut = 143.4 kN/m run
 At elev. 43.85 Strut force = 24.8 kN/strut = 24.8 kN/m run

(continued)

Stage No.9 Change EI of wall to 43355 kN.m2/m run
Yield moment not defined
Allow wall to relax with new modulus value

Node no.	Y coord	LEFT side					Total earth pressure	Coeff. of subgrade reaction
		Water press.	Vertic -al	Active limit	Passive limit	Earth pressure		
		kN/m2	kN/m2	kN/m2	kN/m2	kN/m2	kN/m2	kN/m3
1	49.75	0.00	0.00	0.00	0.00	0.00	0.00	6145
2	49.40	0.00	7.46	3.06	19.88	19.88	19.88p	6145
3	49.08	3.19	12.71	5.22	33.87	33.87	37.06p	6145
4	48.75	6.38	17.44	7.15	46.45	35.49	41.87	6145
5	48.42	9.56	21.48	8.81	57.21	22.69	32.25	6145
6	48.10	12.75	25.05	10.27	66.72	10.31	23.06	6145
7	47.80	15.70	28.07	11.51	74.78	11.51	27.21a	3019
8	47.50	18.64	30.91	12.68	82.35	12.68	31.32a	3019
		18.64	30.91	12.23	86.18	12.23	30.87a	8700
9	47.00	23.54	35.87	14.19	100.00	14.19	37.73a	8700
10	46.50	28.45	40.58	16.06	113.14	16.06	44.50a	8700
11	46.00	33.35	45.14	17.86	125.83	17.86	51.21a	8700
12	45.50	38.26	49.58	19.62	138.22	19.62	57.87a	8700
13	45.00	43.16	53.95	21.34	150.40	21.34	64.51a	8700
		Total>	97.11	23.75m	182.48	23.75	23.75a	17035
14	44.50	Total>	106.84	26.25m	196.47	26.25	26.25a	17887
15	44.17	Total>	113.14	27.88m	205.55	27.88	27.88a	18441
16	43.85	Total>	119.43	29.50m	214.62	30.52	30.52	18994
17	43.65	Total>	123.30	30.50m	220.20	33.26	33.26	23206
18	43.20	Total>	132.00	32.75m	232.74	39.07	39.07	24126
19	43.00	Total>	135.87	33.75m	238.31	41.31	41.31	24535
20	42.50	Total>	145.53	36.25m	252.25	45.79	45.79	25557
21	42.00	Total>	155.20	40.21	266.18	73.18	73.18	26579
22	41.50	Total>	164.88	45.47	280.13	112.16	112.16	27602
23	41.13	Total>	172.14	49.41	290.59	140.76	140.76	28368
24	40.75	Total>	177.06	51.01	298.71	205.87	205.87	362163

Node no.	Y coord	RIGHT side					Total earth pressure	Coeff. of subgrade reaction
		Water press.	Vertic -al	Active limit	Passive limit	Earth pressure		
		kN/m2	kN/m2	kN/m2	kN/m2	kN/m2	kN/m2	kN/m3
1	49.75	0.00	0.00	0.00	0.00	0.00	0.00	0.0
2	49.40	0.00	0.00	0.00	0.00	0.00	0.00	0.0
3	49.08	0.00	0.00	0.00	0.00	0.00	0.00	0.0
4	48.75	0.00	0.00	0.00	0.00	0.00	0.00	0.0
5	48.42	0.00	0.00	0.00	0.00	0.00	0.00	0.0
6	48.10	0.00	0.00	0.00	0.00	0.00	0.00	0.0
7	47.80	0.00	0.00	0.00	0.00	0.00	0.00	0.0
8	47.50	0.00	0.00	0.00	0.00	0.00	0.00	0.0
9	47.00	0.00	0.00	0.00	0.00	0.00	0.00	0.0
10	46.50	0.00	0.00	0.00	0.00	0.00	0.00	0.0
11	46.00	0.00	0.00	0.00	0.00	0.00	0.00	0.0
12	45.50	0.00	0.00	0.00	0.00	0.00	0.00	0.0
13	45.00	0.00	0.00	0.00	0.00	0.00	0.00	0.0
14	44.50	0.00	0.00	0.00	0.00	0.00	0.00	0.0
15	44.17	0.00	0.00	0.00	0.00	0.00	0.00	0.0
16	43.85	0.00	0.00	0.00	0.00	0.00	0.00	0.0
17	43.65	0.00	0.00	0.00	0.00	0.00	0.00	0.0
		0.00	0.00	0.00	0.00	0.00	0.00	3679
18	43.20	0.00	8.10	3.32	21.58	3.32	3.32a	3679
		Total>	8.10	2.25m	108.82	102.18	102.18	24126

(continued)

Stage No.9 Change EI of wall to 43355 kN.m2/m run
 Yield moment not defined
 Allow wall to relax with new modulus value

Node no.	Y coord	----- RIGHT side -----						Total earth pressure	Coeff. of subgrade reaction
		Water press.	Vertical	Effective Active limit	Effective Passive limit	Earth pressure	Earth pressure		
		kN/m2	kN/m2	kN/m2	kN/m2	kN/m2	kN/m2	kN/m3	
19	43.00	Total>	12.10	3.25m	114.53	106.65	106.65	24535	
20	42.50	Total>	22.10	5.75m	128.80	118.93	118.93	25557	
21	42.00	Total>	32.10	8.25m	143.07	133.01	133.01	26579	
22	41.50	Total>	42.10	10.75m	157.34	148.80	148.80	27602	
23	41.13	Total>	49.61	12.63m	168.04	111.81	111.81	28368	
24	40.75	Total>	57.11	14.50m	178.75	24.43	24.43	362163	

Note: 3.32a Soil pressure at active limit
 37.06p Soil pressure at passive limit

Units: kN,m

Stage No.9 Change EI of wall to 43355kN.m2/m run

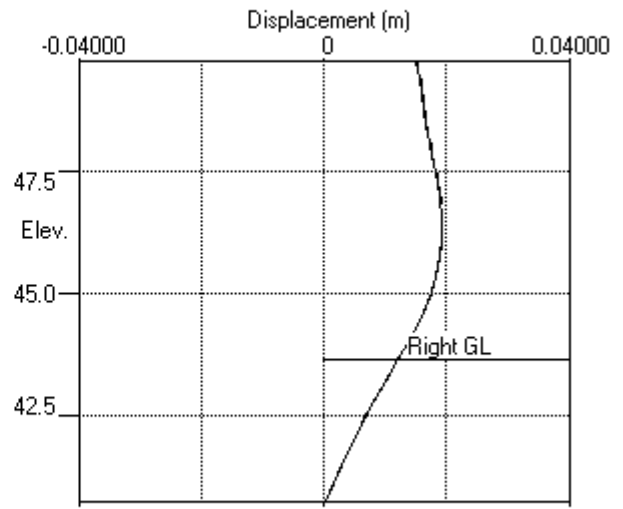
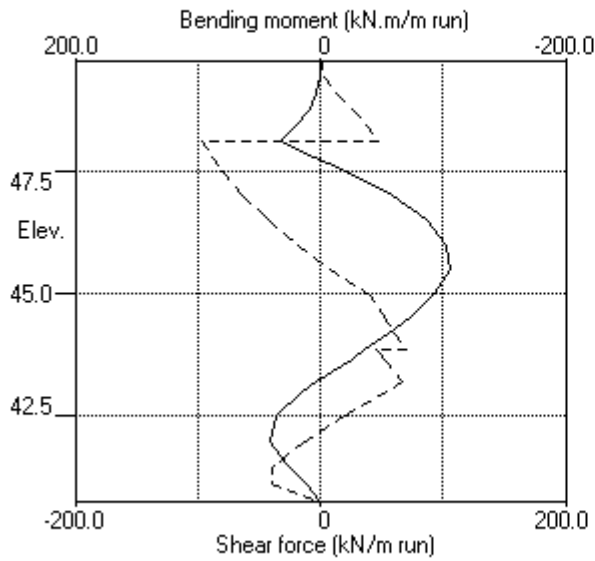

Stage No.9 Change EI of wall to 43355kN.m2/m run

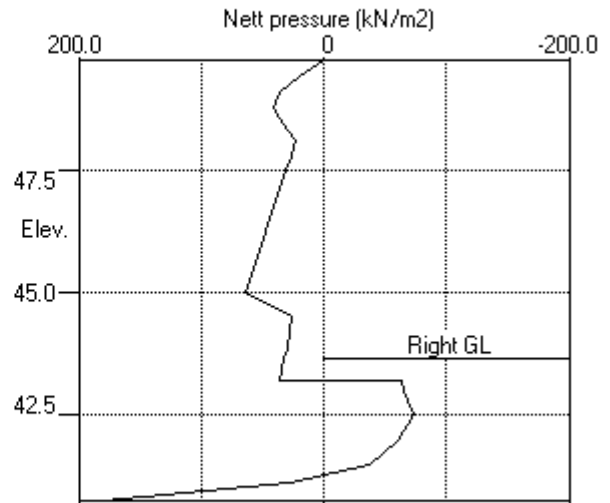
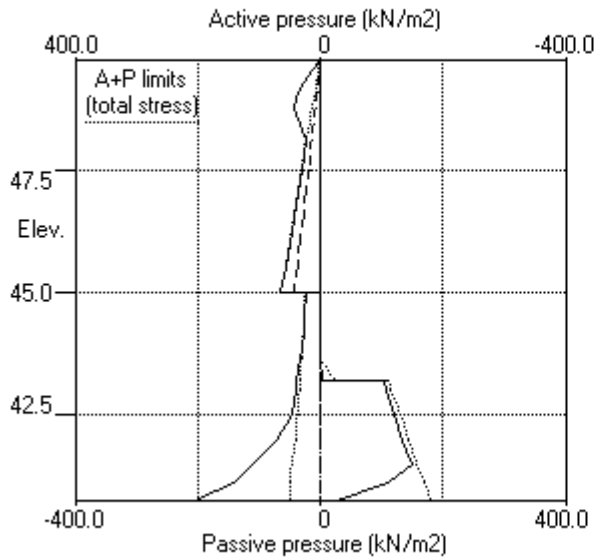

PILEDESIGNS LTD
 Program: WALLAP Version 6.06 Revision A51.B69.R54
 Licensed from GEOSOLVE
 Data filename/Run ID: Hampstead_Wall_5_450mm_rev_01_ULS2
 Hampstead - 24-26 Redington Gardens
 Wall 5, Secant-ULS2, 450 dia @ 650 - run 01

Sheet No.
 Job No. 21495
 Made by : DBS
 Date: 1-10-2018
 Checked :

Units: kN,m

Stage No. 10 Change properties of soil type 3 to soil type 4
 Ko pressures will not be reset

STABILITY ANALYSIS of Fully Embedded Wall according to Strength Factor method
 Factor of safety on soil strength

		Overall					
		FoS for toe		Toe elev. for			
		elev. = 40.75		FoS = 1.000			
		-----		-----			
Stage No.	--- G.L. --- Act. Pass.	Strut Elev.	Factor of Safety	Moment of equil. at elev.	Toe elev.	Wall Penetr-ation	Direction of failure
10	49.75 43.65						
				More than one strut.	No FoS calc.		

** FLOW Warning - Weak strata at or below toe of wall:
 Active limit > Passive limit
 125.05kN/m2 (left) > 111.33kN/m2 (right) at elev. 40.75
 [40.20+84.86(u)] [89.25+22.07(u)]
 The above pressures include water pressure.

Failure and flow of soil BELOW the toe of the wall may occur if the wall is not toed in to a firm stratum. This may occur even when acceptable factors of safety and displacements have been calculated.

BENDING MOMENT and DISPLACEMENT ANALYSIS of Fully Embedded Wall

Analysis options

Length of wall perpendicular to section = 50.00m
 Subgrade reaction model - Boussinesq Influence coefficients
 Soil deformations are elastic until the active or passive limit is reached
 Open Tension Crack analysis - No

Rigid boundaries: Left side 50.00 from wall
 Right side 50.00 from wall

Limit State: ULS DA1 Combination 2

Node no.	Y coord	Nett pressure kN/m2	Wall disp. m	Wall rotation rad.	Shear force kN/m	Bending moment kN.m/m	Strut forces kN/m	EI of wall kN.m2/m
1	49.75	0.00	0.017	4.71E-05	0.0	0.0		43355
2	49.40	9.20	0.017	4.52E-05	1.6	0.5		43355
3	49.08	29.02	0.017	3.67E-05	7.8	1.8		43355
4	48.75	36.49	0.017	9.57E-06	18.5	5.5		43355
5	48.42	29.60	0.017	-6.14E-05	29.2	13.4		43355
6	48.10	23.13	0.017	-2.04E-04	37.8	24.5	116.8	43355
		23.13	0.017	-2.04E-04	-79.0	24.5		
7	47.80	28.54	0.017	-2.96E-04	-71.3	1.5		43355
8	47.50	33.92	0.017	-2.40E-04	-61.9	-19.0		43355
		38.36	0.017	-2.40E-04	-61.9	-19.0		
9	47.00	51.20	0.017	1.16E-04	-39.5	-45.6		43355
10	46.50	63.31	0.017	6.99E-04	-10.9	-59.4		43355
11	46.00	74.01	0.017	1.34E-03	23.4	-57.5		43355
12	45.50	82.42	0.016	1.84E-03	62.5	-37.0		43355
13	45.00	87.35	0.015	1.98E-03	105.0	5.2		43355
		66.62	0.015	1.98E-03	105.0	5.2		
14	44.50	73.05	0.014	1.52E-03	139.9	64.8		43355
15	44.17	77.56	0.014	8.19E-04	164.4	113.4		43355
16	43.85	82.07	0.013	-2.86E-04	190.3	170.3	341.4	43355
		82.07	0.013	-2.86E-04	-151.1	170.3		
17	43.65	84.85	0.014	-1.03E-03	-134.4	142.6		43355

(continued)

Stage No.10 Change properties of soil type 3 to soil type 4
Ko pressures will not be reset

Node no.	Y coord	----- RIGHT side -----						
		----- Effective stresses -----					Total earth pressure	Coeff. of subgrade reaction
		Water press.	Vertic -al	Active limit	Passive limit	Earth pressure		
kN/m2	kN/m2	kN/m2	kN/m2	kN/m2	kN/m2	kN/m2	kN/m3	
8	47.50	0.00	0.00	0.00	0.00	0.00	0.00	0.0
9	47.00	0.00	0.00	0.00	0.00	0.00	0.00	0.0
10	46.50	0.00	0.00	0.00	0.00	0.00	0.00	0.0
11	46.00	0.00	0.00	0.00	0.00	0.00	0.00	0.0
12	45.50	0.00	0.00	0.00	0.00	0.00	0.00	0.0
13	45.00	0.00	0.00	0.00	0.00	0.00	0.00	0.0
14	44.50	0.00	0.00	0.00	0.00	0.00	0.00	0.0
15	44.17	0.00	0.00	0.00	0.00	0.00	0.00	0.0
16	43.85	0.00	0.00	0.00	0.00	0.00	0.00	0.0
17	43.65	0.00	0.00	0.00	0.00	0.00	0.00	0.0
		0.00	0.00	0.00	0.00	0.00	0.00	4290
18	43.20	0.00	8.10	3.32	21.58	21.58	21.58p	4290
		0.00	8.10	3.44	20.63	20.63	20.63p	15019
19	43.00	0.00	12.10	5.14	30.82	30.82	30.82p	15273
20	42.50	4.90	17.20	7.31	43.80	43.80	48.71p	15910
21	42.00	9.81	22.29	9.48	56.79	56.79	66.60p	16546
22	41.50	14.71	27.39	11.64	69.77	69.77	84.49p	17182
23	41.13	18.39	31.21	13.27	79.51	79.51	97.90p	17660
24	40.75	22.07	35.04	14.89	89.25	89.25	111.33p	18137

Note: 125.05a Soil pressure at active limit
111.33p Soil pressure at passive limit

Units: kN,m

Stage No.10 Change soil type 3 to soil type 4

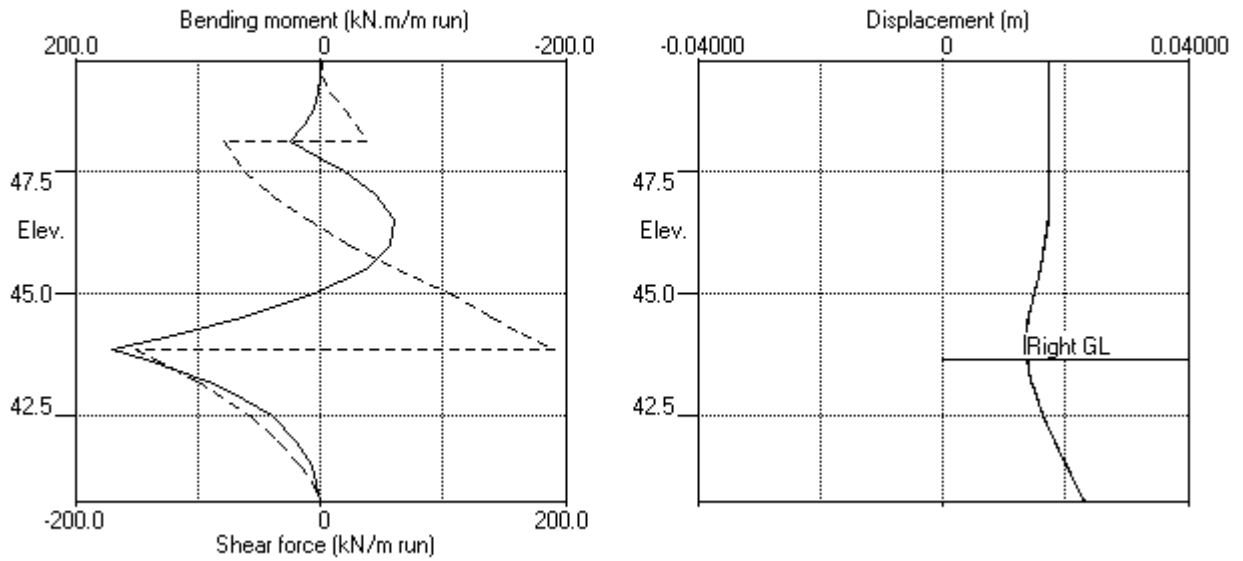

Stage No.10 Change soil type 3 to soil type 4

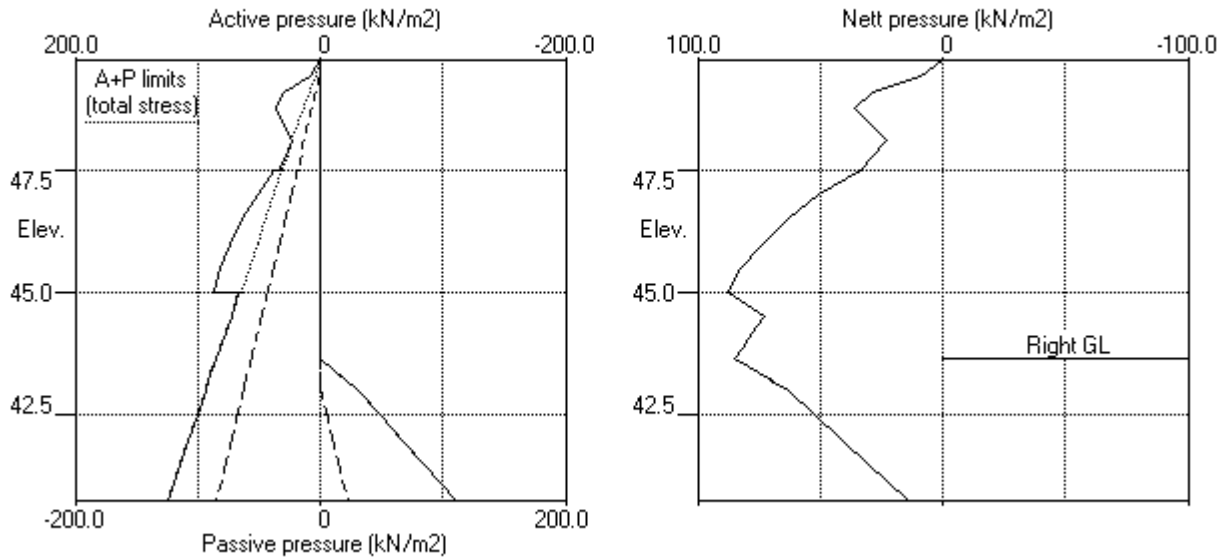

PILEDESIGNS LTD
 Program: WALLAP Version 6.06 Revision A51.B69.R54
 Licensed from GEOSOLVE
 Data filename/Run ID: Hampstead_Wall_5_450mm_rev_01_ULS2
 Hampstead - 24-26 Redington Gardens
 Wall 5, Secant-ULS2, 450 dia @ 650 - run 01

Sheet No.
 Job No. 21495
 Made by : DBS
 Date: 1-10-2018
 Checked :

Units: kN,m

Summary of results

LIMIT STATE PARAMETERS

Limit State: ULS DA1 Combination 2
 Water pressures : Worst Credible
 Partial factor on C' = 1.250
 Partial factor on Phi' = 1.250
 Partial factor on Cu = 1.400
 Partial factor on Soil Modulus = 1.000
 Partial factor on Permanent Unfavourable loads = 1.000
 Partial factor on Permanent Favourable loads = 1.000
 Partial factor on Variable Unfavourable loads = 1.300

STABILITY ANALYSIS of Fully Embedded Wall according to Strength Factor method

Factor of safety on soil strength

			Overall						
			FoS for toe		Toe elev. for				
			elev. = 40.75		FoS = 1.000				

Stage No.	--- G.L. Act.	--- Pass.	Strut Elev.	Factor of Safety	Moment at elev.	Toe elev.	Wall Penetr-ation	Direction of failure	
1	49.75	49.75	Cant.	Conditions not suitable for FoS calc.					
2	49.75	49.75	Cant.	Conditions not suitable for FoS calc.					
3	49.75	47.80	Cant.	1.625	41.79	42.95	4.85	L to R	
4	49.75	47.80		No analysis at this stage					
5	49.75	47.80	48.10	Conditions not suitable for FoS calc.					
6	49.75	43.20	48.10	1.348	n/a	42.20	1.00	L to R	
7	49.75	43.65	48.10	1.411	n/a	42.31	1.34	L to R	
8	49.75	43.65		No analysis at this stage					
9	49.75	43.65		More than one strut. No FoS calc.					
10	49.75	43.65		More than one strut. No FoS calc. **FLOW Warning					
11	49.75	43.65		No analysis at this stage					
12	49.75	43.65		More than one strut. No FoS calc.					

Legend: **FLOW Warning

Failure and flow of soil BELOW the toe of the wall may occur if the wall is not toed in to a firm stratum. It may occur even when acceptable factors of safety and displacements have been calculated. See individual stage results for details.

PILEDESIGNS LTD
 Program: WALLAP Version 6.06 Revision A51.B69.R54
 Licensed from GEOSOLVE
 Data filename/Run ID: Hampstead_Wall_5_450mm_rev_01_ULS2
 Hampstead - 24-26 Redington Gardens
 Wall 5, Secant-ULS2, 450 dia @ 650 - run 01

Sheet No.
 Job No. 21495
 Made by : DBS
 Date: 1-10-2018
 Checked :

Units: kN,m

Summary of results

BENDING MOMENT and DISPLACEMENT ANALYSIS of Fully Embedded Wall

Analysis options

Length of wall perpendicular to section = 50.00m
 Subgrade reaction model - Boussinesq Influence coefficients
 Soil deformations are elastic until the active or passive limit is reached
 Open Tension Crack analysis - No

Rigid boundaries: Left side 50.00 from wall
 Right side 50.00 from wall

Limit State: ULS DA1 Combination 2

Bending moment, shear force and displacement envelopes

Node no.	Y coord	Displacement		Bending moment		Shear force	
		maximum m	minimum m	maximum kN.m/m	minimum kN.m/m	maximum kN/m	minimum kN/m
1	49.75	0.026	0.000	0.0	0.0	0.0	0.0
2	49.40	0.024	0.000	0.5	-0.0	3.5	-0.9
3	49.08	0.022	0.000	3.0	-0.5	12.7	-2.1
4	48.75	0.021	0.000	8.7	-1.3	25.6	-2.4
5	48.42	0.019	0.000	19.2	-2.0	37.6	-1.7
6	48.10	0.017	0.000	33.2	-2.3	46.6	-103.2
7	47.80	0.018	0.000	15.8	-2.0	25.4	-95.7
8	47.50	0.018	0.000	24.5	-24.4	32.0	-86.9
9	47.00	0.019	0.000	41.9	-63.8	37.2	-69.7
10	46.50	0.019	0.000	60.6	-93.7	37.0	-49.2
11	46.00	0.019	0.000	77.8	-112.5	31.2	-25.2
12	45.50	0.019	0.000	90.7	-118.5	62.5	0.0
13	45.00	0.017	0.000	97.8	-108.8	105.0	0.0
14	44.50	0.016	0.000	89.7	-91.0	139.9	-26.3
15	44.17	0.015	0.000	113.4	-75.1	164.4	-36.1
16	43.85	0.013	0.000	170.3	-55.9	190.3	-151.1
17	43.65	0.014	0.000	142.6	-42.4	71.1	-134.4
18	43.20	0.014	0.000	93.1	-8.1	85.5	-99.7
19	43.00	0.015	0.000	79.0	0.0	70.8	-86.3
20	42.50	0.016	0.000	48.2	0.0	30.5	-57.6
21	42.00	0.018	0.000	41.7	0.0	0.0	-39.5
22	41.50	0.020	0.000	28.0	0.0	0.0	-38.4
23	41.13	0.022	0.000	12.7	0.0	0.0	-42.1
24	40.75	0.023	0.000	0.0	0.0	0.0	0.0

Maximum and minimum bending moment and shear force at each stage

Stage no.	Bending moment				Shear force			
	maximum kN.m/m	elev.	minimum kN.m/m	elev.	maximum kN/m	elev.	minimum kN/m	elev.
1	1.8	43.65	-2.8	46.50	3.6	45.00	-1.3	47.80
2	4.8	44.17	-2.3	48.10	4.6	47.50	-2.4	48.75
3	97.8	45.00	0.0	49.75	37.2	47.00	-40.2	43.65
4	No calculation at this stage							
5	92.5	45.00	0.0	49.75	32.6	46.50	-38.5	43.65
6	41.0	42.00	-117.6	45.50	83.8	43.20	-102.8	48.10
7	41.7	42.00	-118.5	45.50	85.5	43.20	-103.2	48.10
8	No calculation at this stage							
9	40.8	42.00	-105.4	45.50	69.8	43.85	-96.9	48.10
10	170.3	43.85	-59.4	46.50	190.3	43.85	-151.1	43.85
11	No calculation at this stage							
12	148.8	43.85	-63.0	46.00	182.3	43.85	-107.7	43.85

Summary of results (continued)

Maximum and minimum displacement at each stage

Stage no.	Displacement maximum m	Displacement elev.	Displacement minimum m	Displacement elev.	Stage description
1	0.001	49.75	0.000	49.75	Apply surcharge no.1 at elev. 49.75
2	0.002	49.75	0.000	49.75	Apply water pressure profile no.1
3	0.026	49.75	0.000	49.75	Excav. to elev. 47.80 on RIGHT side
4	No calculation at this stage				Install strut no.1 at elev. 48.10
5	0.026	49.75	0.000	49.75	Apply water pressure profile no.2
6	0.019	46.50	0.000	49.75	Excav. to elev. 43.20 on RIGHT side
7	0.019	46.50	0.000	49.75	Fill to elev. 43.65 on RIGHT side
8	No calculation at this stage				Install strut no.2 at elev. 43.85
9	0.019	46.50	0.000	49.75	Change EI of wall to 43355kN.m2/m run
10	0.023	40.75	0.000	49.75	Change soil type 3 to soil type 4
11	No calculation at this stage				Apply surcharge no.2 at elev. 43.65
12	0.021	40.75	0.000	49.75	Apply water pressure profile no.3

Strut forces at each stage (horizontal components)

Stage no.	Strut no. 1 at elev. 48.10		Strut no. 2 at elev. 43.85	
	kN/m run	kN/strut	kN/m run	kN/strut
5	7.97	7.97	---	---
6	148.71	148.71	---	---
7	149.07	149.07	---	---
9	143.45	143.45	24.84	24.84
10	116.80	116.80	341.44	341.44
12	120.11	120.11	290.04	290.04

Units: kN,m

Bending moment, shear force, displacement envelopes

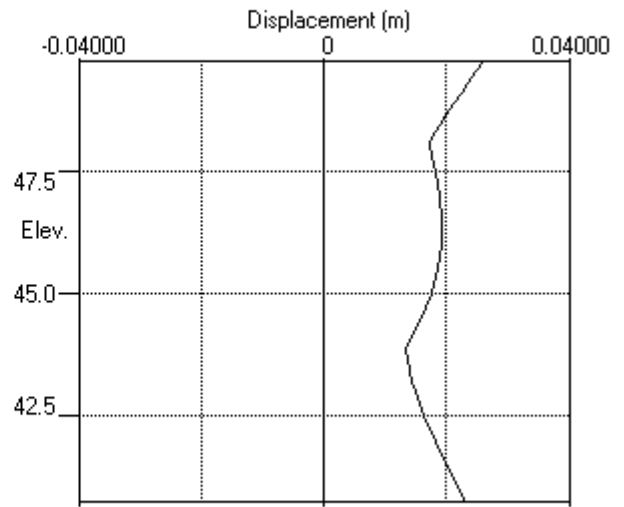
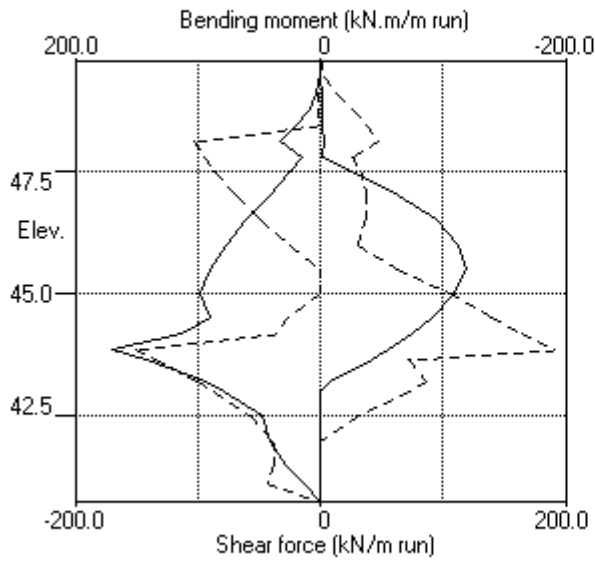



WALLAP

5-SLS

PILEDESIGNS LTD
 Program: WALLAP Version 6.06 Revision A51.B69.R54
 Licensed from GEOSOLVE
 Data filename/Run ID: Hampstead_Wall_5_450mm_rev_01_SLS
 Hampstead - 24-26 Redington Gardens
 Wall 5, Secant-SLS, 450 dia @ 650 - run 01

Sheet No.
 Job No. 21495
 Made by : DBS
 Date: 1-10-2018
 Checked :

Units: kN,m

INPUT DATA

SOIL PROFILE

Stratum no.	Elevation of top of stratum	Soil types	
		Left side	Right side
1	49.75	1 Made Ground dr	1 Made Ground dr
2	47.50	2 Claygate Clay dr	2 Claygate Clay dr
3	45.00	3 London Clay und	3 London Clay und

SOIL PROPERTIES

No. Description (Datum elev.)	Bulk density kN/m3	Young's Modulus Eh, kN/m2 (dEh/dy)	At rest coeff. Ko (dKo/dy)	Consol state. NC/OC (Nu)	Active limit Ka (Kac)	Passive limit Kp (Kpc)	Cohesion kN/m2 (dc/dy)
1 Made Ground dr	18.00	10000	0.530	OC (0.250)	0.337 (0.000)	3.442 (0.000)	
2 Claygate Clay dr	19.00	30000	1.000	NC (0.200)	0.323 (1.330)	3.647 (5.195)	0.0d
3 London Cl.. (45.00)	20.00	40000 (4000)	1.000	OC (0.490)	1.000 (2.476)	1.000 (2.390)	50.00u (5.000)
4 London Cl.. (45.00)	20.00	30800 (3080)	1.000	OC (0.200)	0.351 (1.391)	3.253 (4.831)	0.0d

Additional soil parameters associated with Ka and Kp

No. Description	--- parameters for Ka ---			--- parameters for Kp ---		
	Soil friction angle	Wall adhesion coeff.	Back-fill angle	Soil friction angle	Wall adhesion coeff.	Back-fill angle
1 Made Ground dr	26.00	0.670	0.00	26.00	0.500	0.00
2 Claygate Clay dr	27.00	0.670	0.00	27.00	0.500	0.00
3 London Clay und	0.00	0.670	0.00	0.00	0.500	0.00
4 London Clay dr	25.00	0.670	0.00	25.00	0.500	0.00

GROUND WATER CONDITIONS

Density of water = 9.810 kN/m3

	Left side	Right side
Initial water table elevation	49.40	49.40

Automatic water pressure balancing at toe of wall : No

Water profile no.	Left side				Right side			
	Point no.	Elev. m	Piezo elev. m	Water press. kN/m2	Point no.	Elev. m	Piezo elev. m	Water press. kN/m2
1	1	49.40	49.40	0.0	1	47.50	47.50	0.0 MC+WC
2	1	49.40	49.40	0.0	1	43.00	43.00	0.0 MC+WC
3	1	49.40	49.40	0.0	1	43.65	43.65	0.0 MC+WC
					2	43.65	49.40	56.4

WALL PROPERTIES

Type of structure = Fully Embedded Wall
 Elevation of toe of wall = 40.75
 Maximum finite element length = 0.50 m
 Youngs modulus of wall E = 1.9600E+07 kN/m2
 Moment of inertia of wall I = 3.0968E-03 m4/m run
 E.I = 60696 kN.m2/m run
 Yield Moment of wall = Not defined

STRUTS and ANCHORS

Strut/ anchor no.	Elev.	Strut spacing m	X-section area of strut sq.m	Youngs modulus kN/m ²	Free length m	Inclin -ation (degs)	Pre- stress /strut kN	Tension allowed
1	48.10	1.00	0.400000	1.400E+07	5.00	0.00	0	No
2	43.85	1.00	0.300000	1.400E+07	5.00	0.00	0	No

SURCHARGE LOADS

Surch -arge no.	Elev.	Distance from wall	Length parallel to wall	Width perpend. to wall	Surcharge ----- kN/m ² ----- Near edge Far edge		Equiv. soil type	Partial factor/ Category
1	49.75	0.50(L)	10.00	10.00	10.00	=	N/A	1.00 Var
2	43.65	-0.00(R)	10.00	10.00	57.00	=	N/A	1.00 P/F

Note: L = Left side, R = Right side

Limit State Categories P/U = Permanent Unfavourable
P/F = Permanent Favourable
Var = Variable (unfavourable)

CONSTRUCTION STAGES

Construction stage no.	Stage description
1	Apply surcharge no.1 at elevation 49.75
2	Apply water pressure profile no.1 (Mod. Conserv.)
3	Excavate to elevation 47.80 on RIGHT side
4	Install strut or anchor no.1 at elevation 48.10
5	Apply water pressure profile no.2 (Mod. Conserv.)
6	Excavate to elevation 43.65 on RIGHT side
7	Install strut or anchor no.2 at elevation 43.85
8	Change EI of wall to 43355 kN.m ² /m run Yield moment not defined Allow wall to relax with new modulus value
9	Change properties of soil type 3 to soil type 4 Ko pressures will not be reset
10	Apply surcharge no.2 at elevation 43.65 No analysis at this stage
11	Apply water pressure profile no.3 (Mod. Conserv.)

FACTORS OF SAFETY and ANALYSIS OPTIONS

Limit State options: Serviceability Limit State
All loads and soil strengths are unfactored

Stability analysis:

Method of analysis - Strength Factor method
Factor on soil strength for calculating wall depth = 1.50

Parameters for undrained strata:

Minimum equivalent fluid density = 5.00 kN/m³
Maximum depth of water filled tension crack = 0.00 m

Bending moment and displacement calculation:

Method - Subgrade reaction model using Influence Coefficients
Open Tension Crack analysis? - No
Non-linear Modulus Parameter (L) = 9.000 m

Boundary conditions:

Length of wall (normal to plane of analysis) = 50.00 m

Width of excavation on Left side of wall = 50.00 m
Width of excavation on Right side of wall = 50.00 m

Distance to rigid boundary on Left side = 50.00 m
Distance to rigid boundary on Right side = 50.00 m

OUTPUT OPTIONS

Stage no.	Stage description	Displacement	Active, Passive pressures	Graph. output
1	Apply surcharge no.1 at elev. 49.75	No	No	No
2	Apply water pressure profile no.1	Yes	Yes	Yes
3	Excav. to elev. 47.80 on RIGHT side	Yes	Yes	Yes
4	Install strut no.1 at elev. 48.10	Yes	Yes	Yes
5	Apply water pressure profile no.2	Yes	Yes	Yes
6	Excav. to elev. 43.65 on RIGHT side	Yes	Yes	Yes
7	Install strut no.2 at elev. 43.85	Yes	Yes	Yes
8	Change EI of wall to 43355kN.m2/m run	No	No	No
9	Change soil type 3 to soil type 4	No	No	No
10	Apply surcharge no.2 at elev. 43.65	No	No	No
11	Apply water pressure profile no.3	No	No	No
*	Summary output	Yes	-	Yes

Program WALLAP - Copyright (C) 2017 by DL Borin, distributed by GEOSOLVE
150 St. Alphonsus Road, London SW4 7BW, UK www.geosolve.co.uk

Units: kN,m

Stage No.11 Apply water pressure profile no.3 (Mod. Conserv.)

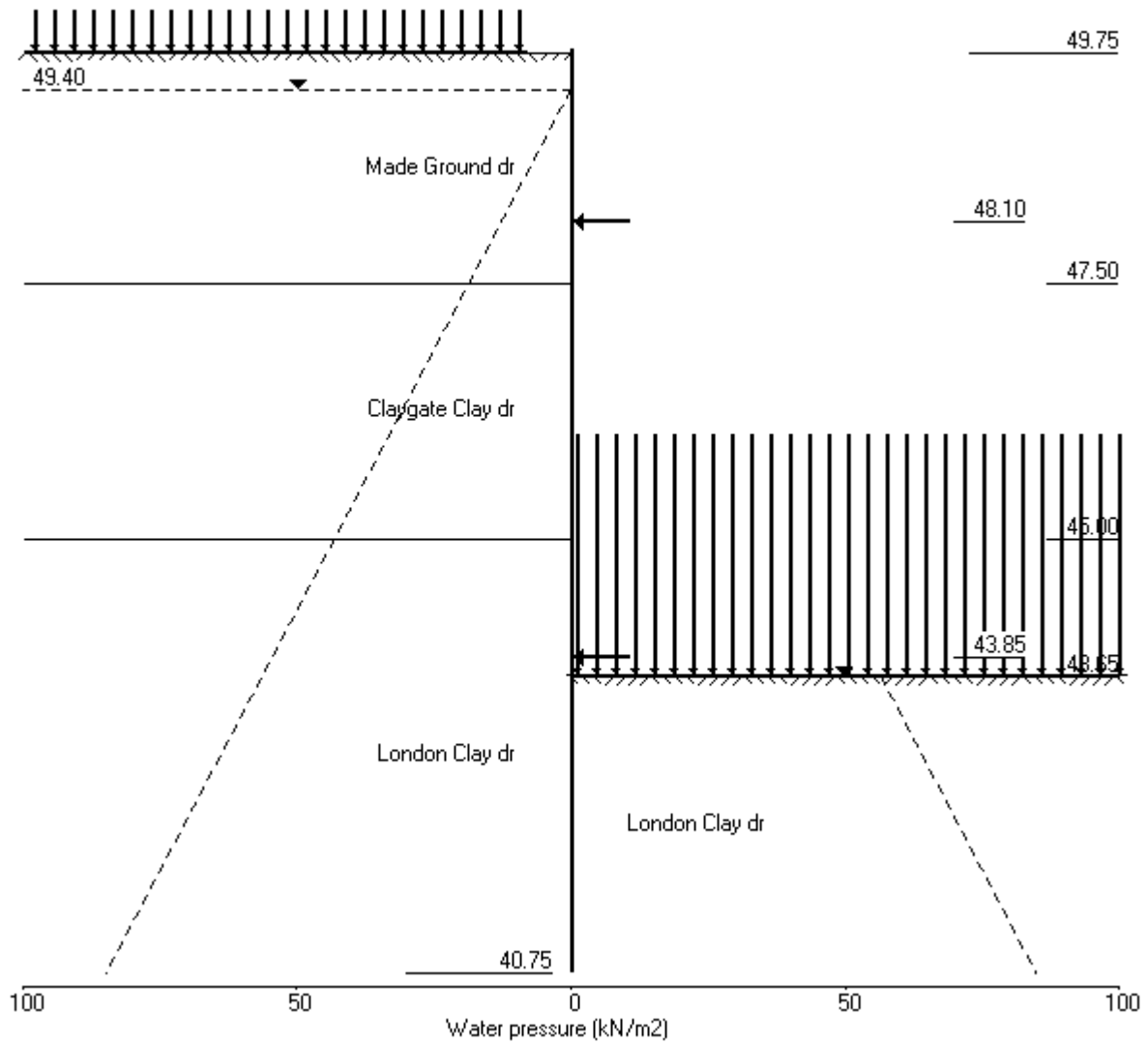

PILEDESIGNS LTD
 Program: WALLAP Version 6.06 Revision A51.B69.R54
 Licensed from GEOSOLVE
 Data filename/Run ID: Hampstead_Wall_5_450mm_rev_01_SLS
 Hampstead - 24-26 Redington Gardens
 Wall 5, Secant-SLS, 450 dia @ 650 - run 01

Sheet No.
 Job No. 21495
 Made by : DBS
 Date: 1-10-2018
 Checked :

Units: kN,m

Stage No. 3 Excavate to elevation 47.80 on RIGHT side

STABILITY ANALYSIS of Fully Embedded Wall according to Strength Factor method
 Factor of safety on soil strength

Stage No.	--- G.L. --- Act.	--- G.L. --- Pass.	Strut Elev.	FoS for toe elev. =	Moment of equil. at elev.	Toe elev. for FoS =	Wall Penetr-ation	Direction of failure
3	49.75	47.80	Cant.	2.237	41.81	42.43	5.37	L to R

BENDING MOMENT and DISPLACEMENT ANALYSIS of Fully Embedded Wall

Analysis options

Length of wall perpendicular to section = 50.00m
 Subgrade reaction model - Boussinesq Influence coefficients
 Soil deformations are elastic until the active or passive limit is reached
 Open Tension Crack analysis - No

Rigid boundaries: Left side 50.00 from wall
 Right side 50.00 from wall

Limit State: Serviceability Limit State

Calculated Bending Moments and Strut Forces are to be multiplied by a factor of 1.35 to obtain values for structural design. See summary for factored values.

Node no.	Y coord	Nett pressure kN/m2	Wall disp. m	Wall rotation rad.	Shear force kN/m	Bending moment kN.m/m	Strut forces kN/m	EI of wall kN.m2/m
1	49.75	0.00	0.013	3.02E-03	0.0	-0.0		60696
2	49.40	2.42	0.012	3.02E-03	0.4	0.1		60696
3	49.08	7.18	0.011	3.02E-03	2.0	0.5		60696
4	48.75	11.79	0.010	3.01E-03	5.1	1.6		60696
5	48.42	16.24	0.009	3.00E-03	9.6	3.9		60696
6	48.10	20.56	0.008	2.97E-03	15.6	8.0		60696
7	47.80	24.47	0.007	2.91E-03	22.4	13.7		60696
8	47.50	9.75	0.006	2.83E-03	27.5	21.3		60696
		8.24	0.006	2.83E-03	27.5	21.3		
9	47.00	-6.94	0.005	2.59E-03	27.8	35.3		60696
10	46.50	-22.19	0.004	2.25E-03	20.5	47.7		60696
11	46.00	-34.98	0.003	1.83E-03	6.2	55.5		60696
12	45.50	-24.25	0.002	1.37E-03	-8.6	55.1		60696
13	45.00	-11.57	0.001	9.50E-04	-17.5	47.8		60696
		-16.18	0.001	9.50E-04	-17.5	47.8		
14	44.50	-2.18	0.001	6.01E-04	-22.1	37.0		60696
15	44.17	3.67	0.001	4.22E-04	-21.9	29.7		60696
16	43.85	7.38	0.001	2.82E-04	-20.1	22.8		60696
17	43.65	8.78	0.001	2.13E-04	-18.5	18.9		60696
18	43.33	9.91	0.001	1.27E-04	-15.4	13.4		60696
19	43.00	9.95	0.001	6.75E-05	-12.2	8.9		60696
20	42.50	8.62	0.001	1.43E-05	-7.6	4.0		60696
21	42.00	6.37	0.001	-7.58E-06	-3.8	1.3		60696
22	41.50	3.76	0.001	-1.38E-05	-1.3	0.2		60696
23	41.13	1.71	0.001	-1.43E-05	-0.3	-0.0		60696
24	40.75	-0.38	0.001	-1.42E-05	0.0	-0.0		---

(continued)

Stage No.3 Excavate to elevation 47.80 on RIGHT side

Node no.	Y coord	----- LEFT side -----					Total earth pressure kN/m2	Coeff. of subgrade reaction kN/m3
		Water press. kN/m2	Vertic -al kN/m2	Effective Active limit kN/m2	Effective Passive limit kN/m2	Earth pressure kN/m2		
1	49.75	0.00	0.00	0.00	0.00	0.00	0.00	3526
2	49.40	0.00	7.20	2.42	24.77	2.42	2.42a	3526
3	49.08	3.19	11.85	3.99	40.78	3.99	7.18a	3526
4	48.75	6.38	16.09	5.42	55.40	5.42	11.79a	3526
5	48.42	9.56	19.82	6.67	68.21	6.67	16.24a	3526
6	48.10	12.75	23.18	7.80	79.79	7.80	20.56a	3526
7	47.80	15.70	26.07	8.78	89.75	8.78	24.47a	3526
8	47.50	18.64	28.82	9.70	99.22	9.70	28.34a	3526
		18.64	28.82	9.30	105.12	9.30	27.94a	10175
9	47.00	23.54	33.70	10.87	122.88	10.87	34.41a	10175
10	46.50	28.45	38.38	12.38	139.98	12.38	40.83a	10175
11	46.00	33.35	42.95	13.85	156.62	16.34	49.70	10175
12	45.50	38.26	47.42	15.30	172.95	28.76	67.02	10175
13	45.00	43.16	51.85	16.72	189.07	38.84	82.00	10175
		Total>	95.01	23.75m	214.51	69.27	69.27	19652
14	44.50	Total>	104.80	26.25m	230.27	85.29	85.29	20634
15	44.17	Total>	111.15	27.88m	240.50	94.28	94.28	21273
16	43.85	Total>	117.49	29.50m	250.73	102.36	102.36	21912
17	43.65	Total>	121.39	30.50m	257.02	106.94	106.94	22305
18	43.33	Total>	127.72	32.12m	267.23	113.89	113.89	22944
19	43.00	Total>	134.05	33.75m	277.45	120.36	120.36	23582
20	42.50	Total>	143.80	36.25m	293.17	129.70	129.70	24565
21	42.00	Total>	153.54	38.75m	308.89	138.64	138.64	25547
22	41.50	Total>	163.29	41.25m	324.61	147.43	147.43	26530
23	41.13	Total>	170.61	43.13m	336.41	153.98	153.98	27267
24	40.75	Total>	176.09	45.00m	346.37	160.52	160.52	28004

Node no.	Y coord	----- RIGHT side -----					Total earth pressure kN/m2	Coeff. of subgrade reaction kN/m3
		Water press. kN/m2	Vertic -al kN/m2	Effective Active limit kN/m2	Effective Passive limit kN/m2	Earth pressure kN/m2		
1	49.75	0.00	0.00	0.00	0.00	0.00	0.00	0.0
2	49.40	0.00	0.00	0.00	0.00	0.00	0.00	0.0
3	49.08	0.00	0.00	0.00	0.00	0.00	0.00	0.0
4	48.75	0.00	0.00	0.00	0.00	0.00	0.00	0.0
5	48.42	0.00	0.00	0.00	0.00	0.00	0.00	0.0
6	48.10	0.00	0.00	0.00	0.00	0.00	0.00	0.0
7	47.80	0.00	0.00	0.00	0.00	0.00	0.00	0.0
		0.00	0.00	0.00	0.00	0.00	0.00	4799
8	47.50	0.00	5.40	1.82	18.59	18.59	18.59p	4799
		0.00	5.40	1.74	19.69	19.69	19.69p	13879
9	47.00	4.90	10.00	3.22	36.45	36.45	41.36p	13879
10	46.50	9.81	14.59	4.71	53.21	53.21	63.02p	13879
11	46.00	14.71	19.19	6.19	69.97	69.97	84.68p	13879
12	45.50	19.62	23.78	7.67	86.73	71.65	91.27	13879
13	45.00	24.52	28.38	9.15	103.49	69.04	93.57	13879
		Total>	52.90	14.00m	172.40	85.45	85.45	26260
14	44.50	Total>	62.90	16.50m	188.38	87.47	87.47	27573
15	44.17	Total>	69.41	18.13m	198.76	90.62	90.62	28427
16	43.85	Total>	75.91	19.75m	209.15	94.98	94.98	29280
17	43.65	Total>	79.91	20.75m	215.54	98.16	98.16	29805
18	43.33	Total>	86.41	22.37m	225.92	103.98	103.98	30659
19	43.00	Total>	92.91	24.00m	236.31	110.41	110.41	31512

(continued)

Stage No.3 Excavate to elevation 47.80 on RIGHT side

Node no.	Y coord	----- RIGHT side -----					Total earth pressure	Coeff. of subgrade reaction
		Water press. kN/m2	Vertical kN/m2	Effective Active limit kN/m2	Effective Passive limit kN/m2	Earth pressure kN/m2		
20	42.50	Total>	102.92	26.50m	252.29	121.08	121.08	32825
21	42.00	Total>	112.92	29.00m	268.27	132.27	132.27	34138
22	41.50	Total>	122.93	31.50m	284.25	143.67	143.67	35451
23	41.13	Total>	130.43	33.37m	296.24	152.27	152.27	36436
24	40.75	Total>	137.94	35.25m	308.22	160.89	160.89	37421

Note: 40.83a Soil pressure at active limit
 84.68p Soil pressure at passive limit

Units: kN,m

Stage No.3 Excav. to elev. 47.80 on RIGHT side

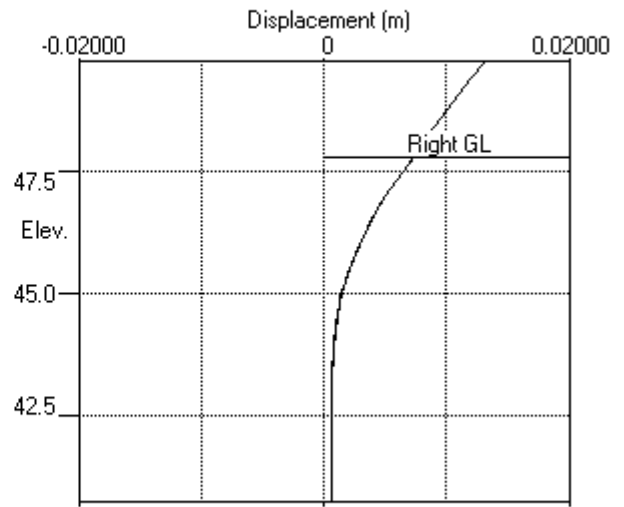
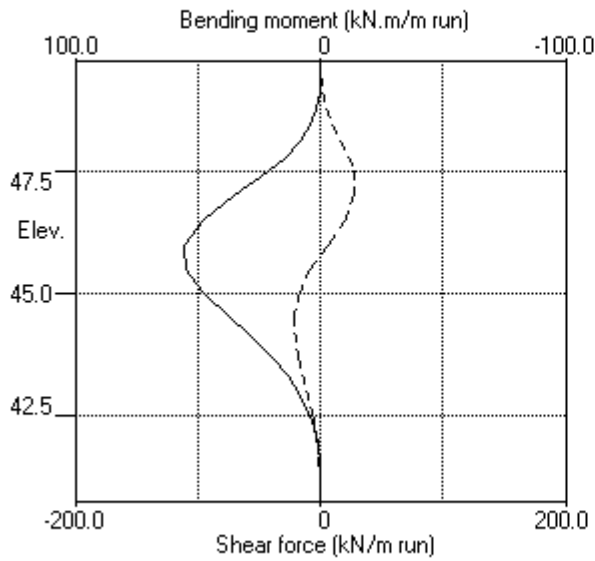

Stage No.3 Excav. to elev. 47.80 on RIGHT side

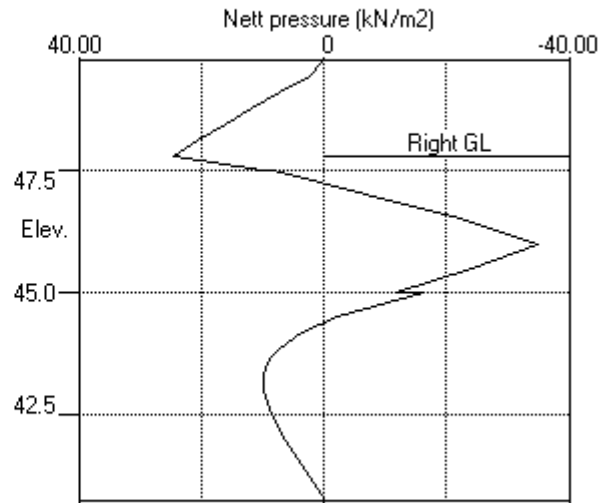
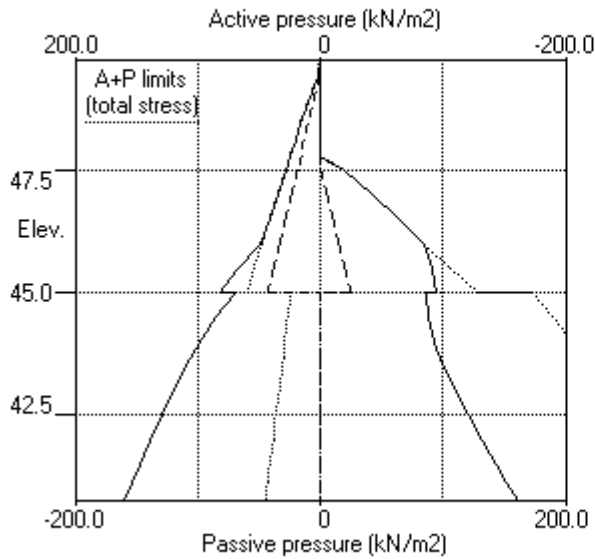

PILEDESIGNS LTD
 Program: WALLAP Version 6.06 Revision A51.B69.R54
 Licensed from GEOSOLVE
 Data filename/Run ID: Hampstead_Wall_5_450mm_rev_01_SLS
 Hampstead - 24-26 Redington Gardens
 Wall 5, Secant-SLS, 450 dia @ 650 - run 01

Sheet No.
 Job No. 21495
 Made by : DBS
 Date: 1-10-2018
 Checked :

Units: kN,m

Stage No. 6 Excavate to elevation 43.65 on RIGHT side

STABILITY ANALYSIS of Fully Embedded Wall according to Strength Factor method
 Factor of safety on soil strength

Stage No.	--- G.L. --- Act.	--- G.L. --- Pass.	Strut Elev.	FoS for toe elev. =	Moment of equil. at elev.	Toe elev. for FoS =	Wall Penetr-ation	Direction of failure
6	49.75	43.65	48.10	40.75	n/a	1.500	1.07	L to R

BENDING MOMENT and DISPLACEMENT ANALYSIS of Fully Embedded Wall

Analysis options

Length of wall perpendicular to section = 50.00m
 Subgrade reaction model - Boussinesq Influence coefficients
 Soil deformations are elastic until the active or passive limit is reached
 Open Tension Crack analysis - No

Rigid boundaries: Left side 50.00 from wall
 Right side 50.00 from wall

Limit State: Serviceability Limit State

Calculated Bending Moments and Strut Forces are to be multiplied by a factor of 1.35 to obtain values for structural design. See summary for factored values.

Node no.	Y coord	Nett pressure kN/m ²	Wall disp. m	Wall rotation rad.	Shear force kN/m	Bending moment kN.m/m	Strut forces kN/m	EI of wall kN.m ² /m
1	49.75	0.00	0.007	-6.75E-04	0.0	-0.0		60696
2	49.40	24.77	0.007	-6.77E-04	4.3	0.6		60696
3	49.08	30.36	0.008	-6.87E-04	13.3	3.0		60696
4	48.75	27.12	0.008	-7.19E-04	22.6	9.0		60696
5	48.42	23.63	0.008	-7.91E-04	30.9	17.9		60696
6	48.10	20.56	0.008	-9.17E-04	38.1	29.3	121.4	60696
		20.56	0.008	-9.17E-04	-83.4	29.3		
7	47.80	24.47	0.009	-1.00E-03	-76.6	5.2		60696
8	47.50	28.34	0.009	-9.74E-04	-68.7	-16.6		60696
		27.94	0.009	-9.74E-04	-68.7	-16.6		
9	47.00	34.41	0.009	-7.11E-04	-53.1	-47.2		60696
10	46.50	40.83	0.010	-2.32E-04	-34.3	-69.2		60696
11	46.00	47.21	0.010	3.82E-04	-12.3	-80.0		60696
12	45.50	53.56	0.009	1.03E-03	12.9	-79.5		60696
13	45.00	59.89	0.009	1.64E-03	41.3	-66.7		60696
		23.75	0.009	1.64E-03	41.3	-66.7		
14	44.50	26.25	0.008	2.09E-03	53.8	-43.6		60696
15	44.17	27.88	0.007	2.27E-03	62.6	-24.8		60696
16	43.85	29.50	0.006	2.35E-03	71.9	-3.1		60696
17	43.65	30.50	0.006	2.33E-03	77.9	11.9		60696
		-105.13	0.006	2.33E-03	77.9	11.9		
18	43.33	-99.71	0.005	2.21E-03	44.6	32.9		60696
19	43.00	-79.18	0.004	2.01E-03	15.5	44.2		60696
20	42.50	-43.00	0.003	1.65E-03	-15.0	42.0		60696
21	42.00	-11.77	0.003	1.36E-03	-28.7	29.2		60696
22	41.50	16.12	0.002	1.19E-03	-27.6	13.3		60696
23	41.13	36.44	0.001	1.13E-03	-17.8	4.1		60696
24	40.75	58.25	0.001	1.12E-03	0.0	0.0		---
At elev. 48.10 Strut force =			121.4 kN/strut =		121.4 kN/m run			

(continued)

Stage No.6 Excavate to elevation 43.65 on RIGHT side

Node no.	Y coord	----- LEFT side -----					Total earth pressure kN/m2	Coeff. of subgrade reaction kN/m3
		Water press. kN/m2	Vertic -al kN/m2	Effective Active limit kN/m2	Effective Passive limit kN/m2	Earth pressure kN/m2		
1	49.75	0.00	0.00	0.00	0.00	0.00	0.00	6491
2	49.40	0.00	7.20	2.42	24.77	24.77	24.77p	6491
3	49.08	3.19	11.85	3.99	40.78	27.17	30.36	6491
4	48.75	6.38	16.09	5.42	55.40	20.75	27.12	6491
5	48.42	9.56	19.82	6.67	68.21	14.06	23.63	6491
6	48.10	12.75	23.18	7.80	79.79	7.80	20.56a	2390
7	47.80	15.70	26.07	8.78	89.75	8.78	24.47a	2390
8	47.50	18.64	28.82	9.70	99.22	9.70	28.34a	2390
		18.64	28.82	9.30	105.12	9.30	27.94a	6868
9	47.00	23.54	33.70	10.87	122.88	10.87	34.41a	6868
10	46.50	28.45	38.38	12.38	139.98	12.38	40.83a	6868
11	46.00	33.35	42.95	13.85	156.62	13.85	47.21a	6868
12	45.50	38.26	47.42	15.30	172.95	15.30	53.56a	6868
13	45.00	43.16	51.85	16.72	189.07	16.72	59.89a	6868
		Total>	95.01	23.75m	214.51	23.75	23.75a	13819
14	44.50	Total>	104.80	26.25m	230.27	26.25	26.25a	14510
15	44.17	Total>	111.15	27.88m	240.50	27.88	27.88a	14959
16	43.85	Total>	117.49	29.50m	250.73	29.50	29.50a	15408
17	43.65	Total>	121.39	30.50m	257.02	30.50	30.50a	15685
18	43.33	Total>	127.72	32.12m	267.23	46.31	46.31	16134
19	43.00	Total>	134.05	33.75m	277.45	61.85	61.85	16583
20	42.50	Total>	143.80	36.25m	293.17	84.31	84.31	17274
21	42.00	Total>	153.54	38.75m	308.89	104.96	104.96	17965
22	41.50	Total>	163.29	41.25m	324.61	124.39	124.39	18656
23	41.13	Total>	170.61	43.13m	336.41	138.76	138.76	19174
24	40.75	Total>	176.09	45.00m	346.37	153.77	153.77	19692

Node no.	Y coord	----- RIGHT side -----					Total earth pressure kN/m2	Coeff. of subgrade reaction kN/m3
		Water press. kN/m2	Vertic -al kN/m2	Effective Active limit kN/m2	Effective Passive limit kN/m2	Earth pressure kN/m2		
1	49.75	0.00	0.00	0.00	0.00	0.00	0.00	0.0
2	49.40	0.00	0.00	0.00	0.00	0.00	0.00	0.0
3	49.08	0.00	0.00	0.00	0.00	0.00	0.00	0.0
4	48.75	0.00	0.00	0.00	0.00	0.00	0.00	0.0
5	48.42	0.00	0.00	0.00	0.00	0.00	0.00	0.0
6	48.10	0.00	0.00	0.00	0.00	0.00	0.00	0.0
7	47.80	0.00	0.00	0.00	0.00	0.00	0.00	0.0
8	47.50	0.00	0.00	0.00	0.00	0.00	0.00	0.0
9	47.00	0.00	0.00	0.00	0.00	0.00	0.00	0.0
10	46.50	0.00	0.00	0.00	0.00	0.00	0.00	0.0
11	46.00	0.00	0.00	0.00	0.00	0.00	0.00	0.0
12	45.50	0.00	0.00	0.00	0.00	0.00	0.00	0.0
13	45.00	0.00	0.00	0.00	0.00	0.00	0.00	0.0
14	44.50	0.00	0.00	0.00	0.00	0.00	0.00	0.0
15	44.17	0.00	0.00	0.00	0.00	0.00	0.00	0.0
16	43.85	0.00	0.00	0.00	0.00	0.00	0.00	0.0
17	43.65	0.00	0.00	0.00	0.00	0.00	0.00	0.0
		Total>	0.00	0.00	135.63	135.63	135.63p	29688
18	43.33	Total>	6.50	1.63m	146.01	146.01	146.01p	30538
19	43.00	Total>	13.00	3.25m	156.40	141.02	141.02	31388
20	42.50	Total>	23.00	5.75m	172.37	127.32	127.32	32696
21	42.00	Total>	33.00	8.25m	188.35	116.73	116.73	34004

(continued)

Stage No.6 Excavate to elevation 43.65 on RIGHT side

Node no.	Y coord	----- Effective stresses -----					Total earth pressure	Coeff. of subgrade reaction
		Water press. kN/m2	Vertic -al kN/m2	Active limit kN/m2	Passive limit kN/m2	Earth pressure kN/m2		
22	41.50	Total>	43.00	10.75m	204.33	108.28	108.28	35312
23	41.13	Total>	50.51	12.63m	216.31	102.32	102.32	36292
24	40.75	Total>	58.01	14.50m	228.29	95.52	95.52	37273

Note: 30.50a Soil pressure at active limit
 146.01p Soil pressure at passive limit

Units: kN,m

Stage No.6 Excav. to elev. 43.65 on RIGHT side

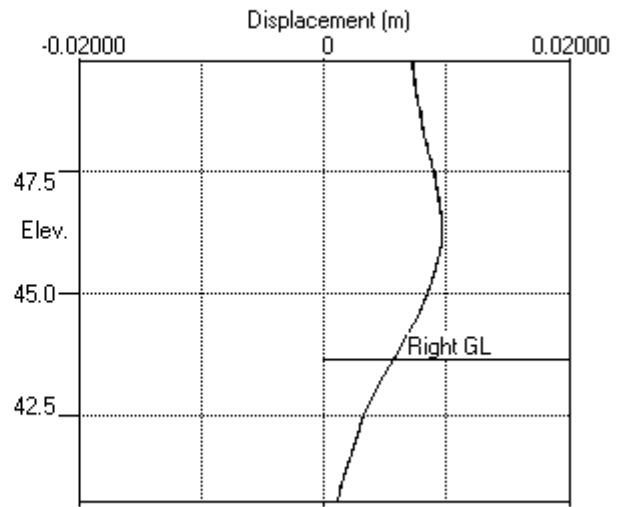
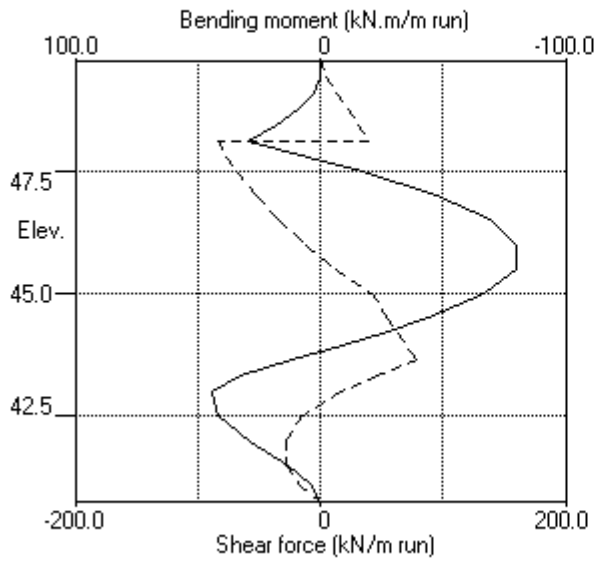

Stage No.6 Excav. to elev. 43.65 on RIGHT side

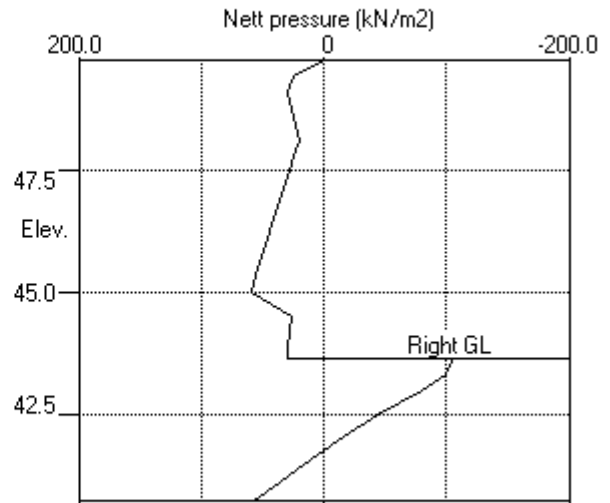
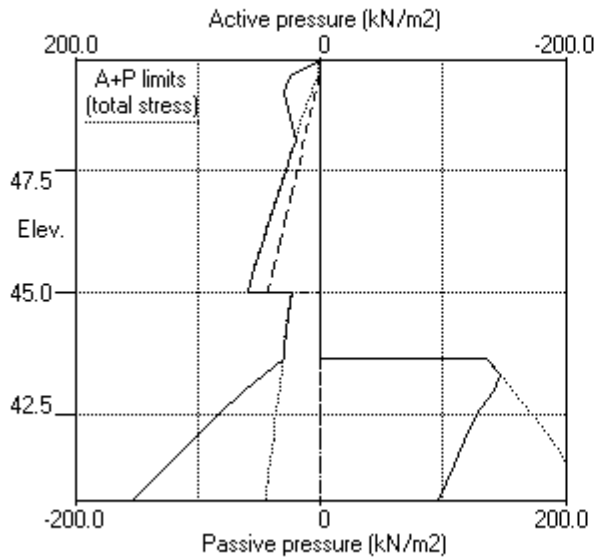

PILEDESIGNS LTD
 Program: WALLAP Version 6.06 Revision A51.B69.R54
 Licensed from GEOSOLVE
 Data filename/Run ID: Hampstead_Wall_5_450mm_rev_01_SLS
 Hampstead - 24-26 Redington Gardens
 Wall 5, Secant-SLS, 450 dia @ 650 - run 01

Sheet No.
 Job No. 21495
 Made by : DBS
 Date: 1-10-2018
 Checked :

Units: kN,m

Stage No. 8 Change EI of wall to 43355 kN.m²/m run
 Yield moment not defined
 Allow wall to relax with new modulus value

STABILITY ANALYSIS of Fully Embedded Wall according to Strength Factor method

Factor of safety on soil strength

			FoS for toe	Toe elev. for		
			elev. = 40.75	FoS = 1.500		
			-----	-----		
Stage	--- G.L. ---	Strut	Factor	Moment	Toe	Wall
No.	Act. Pass.	Elev.	of	equilib.	elev.	Penetr
			Safety	at elev.		-ation
8	49.75 43.65		More than one strut.	No FoS calc.		Direction of failure

BENDING MOMENT and DISPLACEMENT ANALYSIS of Fully Embedded Wall

Analysis options

Length of wall perpendicular to section = 50.00m
 Subgrade reaction model - Boussinesq Influence coefficients
 Soil deformations are elastic until the active or passive limit is reached
 Open Tension Crack analysis - No

Rigid boundaries: Left side 50.00 from wall
 Right side 50.00 from wall

Limit State: Serviceability Limit State

Calculated Bending Moments and Strut Forces are to be multiplied by a factor of 1.35 to obtain values for structural design. See summary for factored values.

Node no.	Y coord	Nett pressure kN/m ²	Wall disp. m	Wall rotation rad.	Shear force kN/m	Bending moment kN.m/m	Strut forces kN/m	EI of wall kN.m ² /m
1	49.75	0.00	0.007	-9.36E-04	0.0	-0.0		43355
2	49.40	24.77	0.007	-9.38E-04	4.3	0.6		43355
3	49.08	32.15	0.007	-9.51E-04	13.6	3.0		43355
4	48.75	28.38	0.008	-9.97E-04	23.4	9.2		43355
5	48.42	24.30	0.008	-1.10E-03	32.0	18.3		43355
6	48.10	20.56	0.008	-1.28E-03	39.3	30.0	120.2	43355
		20.56	0.008	-1.28E-03	-80.9	30.0		
7	47.80	24.47	0.009	-1.41E-03	-74.2	6.5		43355
8	47.50	28.34	0.009	-1.38E-03	-66.2	-14.8		43355
		27.94	0.009	-1.38E-03	-66.2	-14.8		
9	47.00	34.41	0.010	-1.05E-03	-50.6	-44.4		43355
10	46.50	40.83	0.010	-4.29E-04	-31.8	-65.5		43355
11	46.00	47.21	0.010	3.68E-04	-9.8	-75.3		43355
12	45.50	53.56	0.010	1.21E-03	15.4	-73.9		43355
13	45.00	59.89	0.009	1.96E-03	43.7	-60.1		43355
		23.75	0.009	1.96E-03	43.7	-60.1		
14	44.50	26.25	0.008	2.49E-03	56.2	-36.0		43355
15	44.17	27.88	0.007	2.67E-03	65.0	-16.7		43355
16	43.85	29.50	0.006	2.69E-03	74.3	5.7	15.6	43355
		29.50	0.006	2.69E-03	58.7	5.7		
17	43.65	31.61	0.006	2.63E-03	64.9	18.6		43355
		-102.91	0.006	2.63E-03	64.9	18.6		
18	43.33	-93.41	0.005	2.41E-03	33.0	36.4		43355
19	43.00	-70.29	0.004	2.10E-03	6.4	45.0		43355
20	42.50	-33.20	0.003	1.61E-03	-19.5	40.2		43355
21	42.00	-4.10	0.002	1.23E-03	-28.8	26.5		43355
22	41.50	19.76	0.002	1.02E-03	-24.9	11.4		43355
23	41.13	36.47	0.001	9.68E-04	-14.4	3.1		43355

(continued)

Stage No.8 Change EI of wall to 43355 kN.m2/m run
 Yield moment not defined
 Allow wall to relax with new modulus value

Node no.	Y coord	RIGHT side						
		Water press. kN/m2	Vertic -al kN/m2	Effective Active limit kN/m2	Effective Passive limit kN/m2	Earth pressure kN/m2	Total earth pressure kN/m2	Coeff. of subgrade reaction kN/m3
14	44.50	0.00	0.00	0.00	0.00	0.00	0.00	0.0
15	44.17	0.00	0.00	0.00	0.00	0.00	0.00	0.0
16	43.85	0.00	0.00	0.00	0.00	0.00	0.00	0.0
17	43.65	0.00	0.00	0.00	0.00	0.00	0.00	0.0
		Total>	0.00	0.00	135.63	134.52	134.52	24506
18	43.33	Total>	6.50	1.63m	146.01	142.86	142.86	25208
19	43.00	Total>	13.00	3.25m	156.40	136.58	136.58	25909
20	42.50	Total>	23.00	5.75m	172.37	122.42	122.42	26989
21	42.00	Total>	33.00	8.25m	188.35	112.89	112.89	28068
22	41.50	Total>	43.00	10.75m	204.33	106.46	106.46	29148
23	41.13	Total>	50.51	12.63m	216.31	102.30	102.30	139640
24	40.75	Total>	58.01	14.50m	228.29	104.52	104.52	143414

Note: 29.50a Soil pressure at active limit
 24.77p Soil pressure at passive limit

Units: kN,m

Stage No.8 Change EI of wall to 43355kN.m2/m run

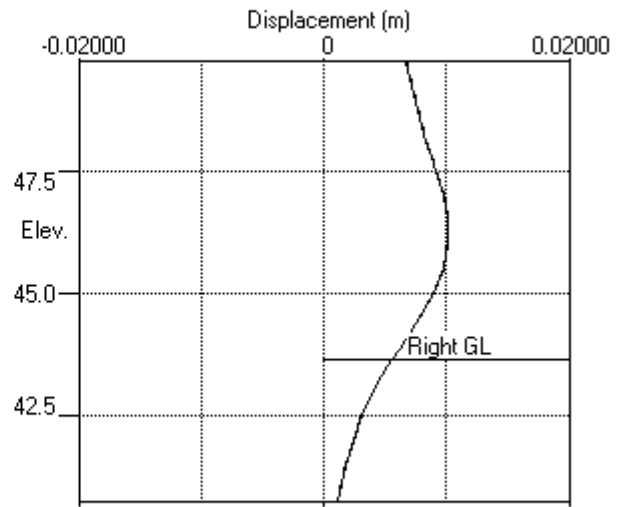
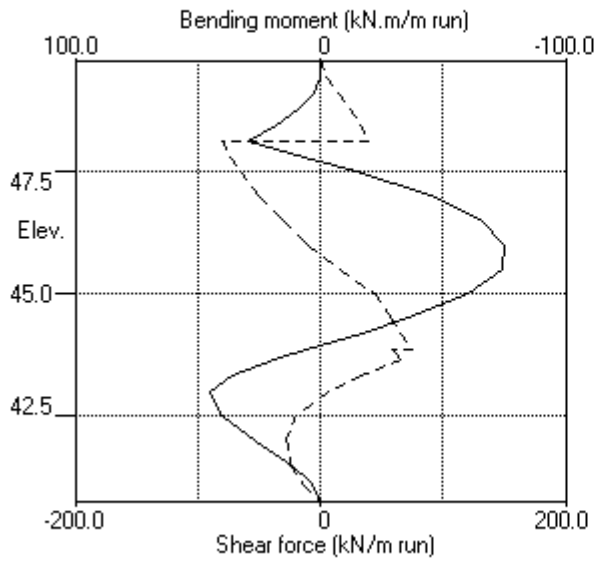

Stage No.8 Change EI of wall to 43355kN.m2/m run

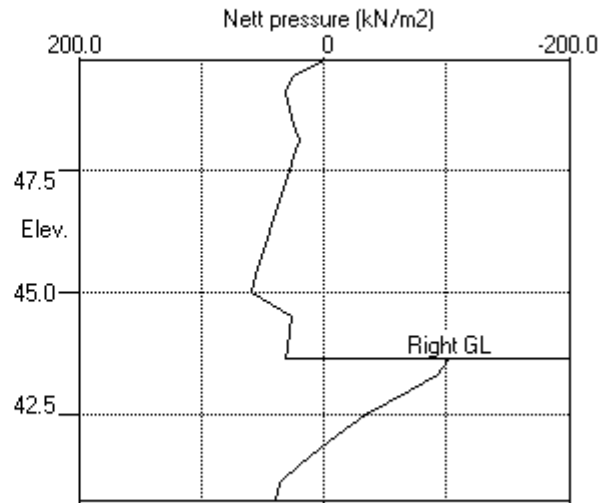
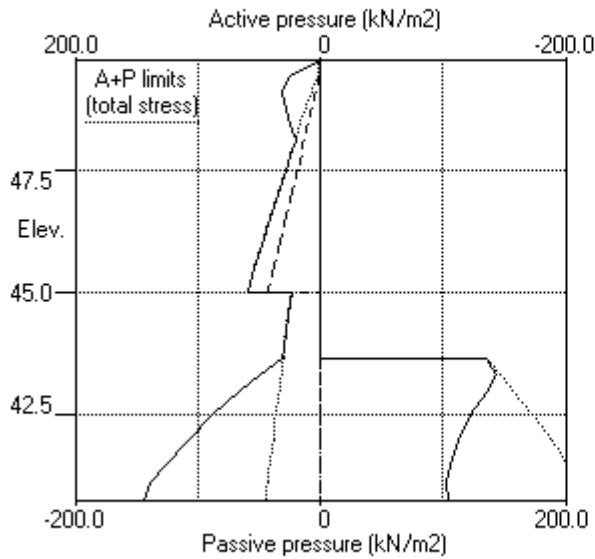

PILEDESIGNS LTD	Sheet No.
Program: WALLAP Version 6.06 Revision A51.B69.R54	Job No. 21495
Licensed from GEOSOLVE	Made by : DBS
Data filename/Run ID: Hampstead_Wall_5_450mm_rev_01_SLS	Date: 1-10-2018
Hampstead - 24-26 Redington Gardens	Checked :
Wall 5, Secant-SLS, 450 dia @ 650 - run 01	

Units: kN,m

Stage No. 9 Change properties of soil type 3 to soil type 4
 Ko pressures will not be reset

STABILITY ANALYSIS of Fully Embedded Wall according to Strength Factor method
 Factor of safety on soil strength

			FoS for toe elev. = 40.75		Toe elev. for FoS = 1.500		
Stage No.	--- G.L. Act.	--- Pass.	Strut Elev.	Factor of Safety	Moment of equil. at elev.	Toe elev. Penetr-ation	Wall Direction of failure
9	49.75	43.65		More than one strut.	No FoS calc.		

BENDING MOMENT and DISPLACEMENT ANALYSIS of Fully Embedded Wall

Analysis options

Length of wall perpendicular to section = 50.00m
 Subgrade reaction model - Boussinesq Influence coefficients
 Soil deformations are elastic until the active or passive limit is reached
 Open Tension Crack analysis - No

Rigid boundaries: Left side 50.00 from wall
 Right side 50.00 from wall

Limit State: Serviceability Limit State

Calculated Bending Moments and Strut Forces are to be multiplied by a factor of 1.35 to obtain values for structural design. See summary for factored values.

Node no.	Y coord	Nett pressure kN/m2	Wall disp. m	Wall rotation rad.	Shear force kN/m	Bending moment kN.m/m	Strut forces kN/m	EI of wall kN.m2/m
1	49.75	0.00	0.007	-7.70E-04	0.0	-0.0		43355
2	49.40	23.37	0.007	-7.72E-04	4.1	0.6		43355
3	49.08	31.10	0.007	-7.85E-04	12.9	2.8		43355
4	48.75	27.68	0.008	-8.29E-04	22.5	8.7		43355
5	48.42	23.96	0.008	-9.28E-04	30.9	17.5		43355
6	48.10	20.57	0.008	-1.10E-03	38.1	28.8	116.3	43355
		20.57	0.008	-1.10E-03	-78.1	28.8		
7	47.80	24.65	0.009	-1.22E-03	-71.4	6.2		43355
8	47.50	28.69	0.009	-1.20E-03	-63.4	-14.2		43355
		28.94	0.009	-1.20E-03	-63.4	-14.2		
9	47.00	36.21	0.010	-8.83E-04	-47.1	-42.3		43355
10	46.50	43.30	0.010	-2.96E-04	-27.2	-61.4		43355
11	46.00	50.13	0.010	4.38E-04	-3.8	-68.6		43355
12	45.50	56.59	0.009	1.18E-03	22.8	-63.8		43355
13	45.00	62.51	0.009	1.79E-03	52.6	-45.8		43355
		61.38	0.009	1.79E-03	52.6	-45.8		
14	44.50	68.00	0.008	2.10E-03	85.0	-12.5		43355
15	44.17	72.29	0.007	2.07E-03	107.8	18.5		43355
16	43.85	76.59	0.006	1.76E-03	132.0	57.1	219.4	43355
		76.59	0.006	1.76E-03	-87.5	57.1		
17	43.65	79.23	0.006	1.53E-03	-71.9	41.8		43355
18	43.33	62.38	0.006	1.27E-03	-48.9	24.3		43355
19	43.00	45.53	0.005	1.12E-03	-31.3	13.8		43355
20	42.50	30.66	0.005	1.03E-03	-12.3	2.4		43355
21	42.00	15.78	0.004	1.03E-03	-0.7	-1.5		43355
22	41.50	0.90	0.004	1.05E-03	3.5	-1.6		43355
23	41.13	-6.98	0.003	1.07E-03	2.4	-0.6		43355
24	40.75	-5.65	0.003	1.07E-03	0.0	-0.0		---
At elev. 48.10 Strut force =			116.3 kN/strut =		116.3 kN/m run			
At elev. 43.85 Strut force =			219.4 kN/strut =		219.4 kN/m run			

(continued)

Stage No.9 Change properties of soil type 3 to soil type 4
Ko pressures will not be reset

Node no.	Y coord	LEFT side						Total earth pressure kN/m2	Coeff. of subgrade reaction kN/m3
		Effective stresses							
		Water press. kN/m2	Vertic -al kN/m2	Active limit kN/m2	Passive limit kN/m2	Earth pressure kN/m2			
1	49.75	0.00	0.00	0.00	0.00	0.00	0.00	6436	
2	49.40	0.00	7.20	2.42	24.77	23.37	23.37	6436	
3	49.08	3.19	11.85	3.99	40.78	27.91	31.10	6436	
4	48.75	6.38	16.09	5.42	55.40	21.30	27.68	6436	
5	48.42	9.56	19.82	6.67	68.21	14.39	23.96	6436	
6	48.10	12.75	23.18	7.80	79.79	7.82	20.57	3069	
7	47.80	15.70	26.07	8.78	89.75	8.96	24.65	3069	
8	47.50	18.64	28.82	9.70	99.22	10.05	28.69	3069	
		18.64	28.82	9.30	105.12	10.30	28.94	8845	
9	47.00	23.54	33.70	10.87	122.88	12.66	36.21	8845	
10	46.50	28.45	38.38	12.38	139.98	14.85	43.30	8845	
11	46.00	33.35	42.95	13.85	156.62	16.78	50.13	8845	
12	45.50	38.26	47.42	15.30	172.95	18.33	56.59	8845	
13	45.00	43.16	51.85	16.72	189.07	19.34	62.51	8845	
		43.16	51.85	18.21	168.64	18.21	61.38a	9081	
14	44.50	48.07	56.73	19.93	184.52	19.93	68.00a	9535	
15	44.17	51.26	59.89	21.04	194.80	21.04	72.29a	9830	
16	43.85	54.45	63.04	22.14	205.06	22.14	76.59a	10442	
17	43.65	56.41	64.98	22.83	211.36	22.83	79.23a	10629	
18	43.33	59.60	68.12	23.93	221.60	23.93	83.53a	10934	
19	43.00	62.78	71.27	25.04	231.82	25.04	87.82a	11238	
20	42.50	67.69	76.11	26.73	247.56	26.73	94.42a	11706	
21	42.00	72.59	80.95	28.43	263.30	28.43	101.03a	12174	
22	41.50	77.50	85.79	30.14	279.06	30.14	107.64a	12643	
23	41.13	81.18	89.43	31.41	290.90	34.69	115.87	12994	
24	40.75	84.86	93.07	32.69	302.75	36.97	121.82	13345	

Node no.	Y coord	RIGHT side						Total earth pressure kN/m2	Coeff. of subgrade reaction kN/m3
		Effective stresses							
		Water press. kN/m2	Vertic -al kN/m2	Active limit kN/m2	Passive limit kN/m2	Earth pressure kN/m2			
1	49.75	0.00	0.00	0.00	0.00	0.00	0.00	0.0	
2	49.40	0.00	0.00	0.00	0.00	0.00	0.00	0.0	
3	49.08	0.00	0.00	0.00	0.00	0.00	0.00	0.0	
4	48.75	0.00	0.00	0.00	0.00	0.00	0.00	0.0	
5	48.42	0.00	0.00	0.00	0.00	0.00	0.00	0.0	
6	48.10	0.00	0.00	0.00	0.00	0.00	0.00	0.0	
7	47.80	0.00	0.00	0.00	0.00	0.00	0.00	0.0	
8	47.50	0.00	0.00	0.00	0.00	0.00	0.00	0.0	
9	47.00	0.00	0.00	0.00	0.00	0.00	0.00	0.0	
10	46.50	0.00	0.00	0.00	0.00	0.00	0.00	0.0	
11	46.00	0.00	0.00	0.00	0.00	0.00	0.00	0.0	
12	45.50	0.00	0.00	0.00	0.00	0.00	0.00	0.0	
13	45.00	0.00	0.00	0.00	0.00	0.00	0.00	0.0	
14	44.50	0.00	0.00	0.00	0.00	0.00	0.00	0.0	
15	44.17	0.00	0.00	0.00	0.00	0.00	0.00	0.0	
16	43.85	0.00	0.00	0.00	0.00	0.00	0.00	0.0	
17	43.65	0.00	0.00	0.00	0.00	0.00	0.00	0.0	
		0.00	0.00	0.00	0.00	0.00	0.00	10629	
18	43.33	0.00	6.50	2.28	21.14	21.14	21.14p	10934	
19	43.00	0.00	13.00	4.57	42.29	42.29	42.29p	11238	
20	42.50	4.90	18.10	6.36	58.86	58.86	63.77p	11706	

(continued)

Stage No.9 Change properties of soil type 3 to soil type 4
 Ko pressures will not be reset

Node no.	Y coord	----- RIGHT side -----					Total earth pressure	Coeff. of subgrade reaction
		Water press.	Vertic -al	Effective Active limit	Effective Passive limit	Earth pressure		
		kN/m2	kN/m2	kN/m2	kN/m2	kN/m2	kN/m2	kN/m3
21	42.00	9.81	23.19	8.15	75.44	75.44	85.25p	12174
22	41.50	14.71	28.29	9.94	92.02	92.02	106.73p	12643
23	41.13	18.39	32.11	11.28	104.45	104.45	122.85p	12994
24	40.75	22.07	35.94	12.62	116.89	105.40	127.47	13345

Note: 107.64a Soil pressure at active limit
 122.85p Soil pressure at passive limit

Units: kN,m

Stage No.9 Change soil type 3 to soil type 4

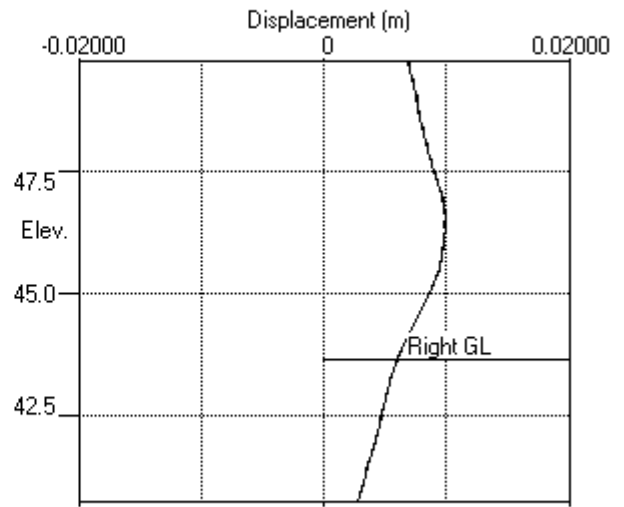
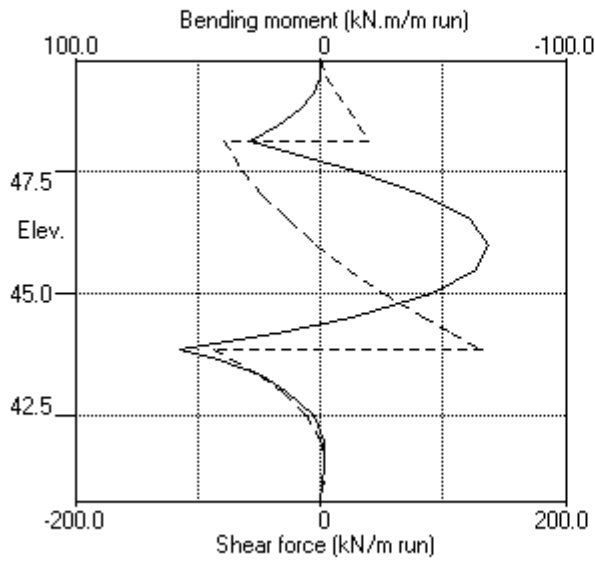

Stage No.9 Change soil type 3 to soil type 4

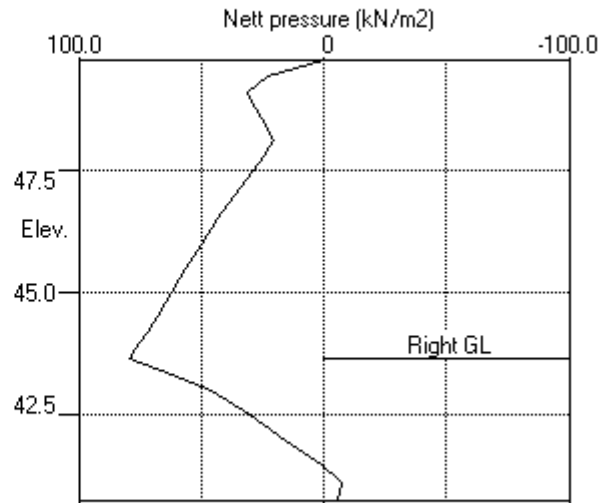
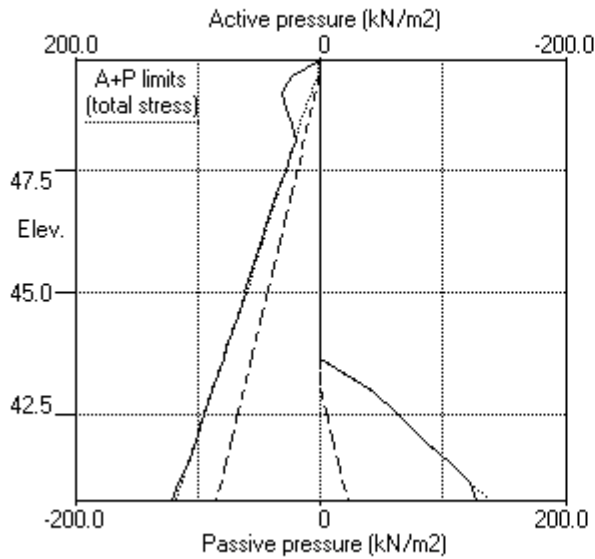

PILEDESIGNS LTD
 Program: WALLAP Version 6.06 Revision A51.B69.R54
 Licensed from GEOSOLVE
 Data filename/Run ID: Hampstead_Wall_5_450mm_rev_01_SLS
 Hampstead - 24-26 Redington Gardens
 Wall 5, Secant-SLS, 450 dia @ 650 - run 01

Sheet No.
 Job No. 21495
 Made by : DBS
 Date: 1-10-2018
 Checked :

 Units: kN,m

Summary of results

LIMIT STATE PARAMETERS

Limit State: Serviceability Limit State
 All loads and soil strengths are unfactored

STABILITY ANALYSIS of Fully Embedded Wall according to Strength Factor method
 Factor of safety on soil strength

Stage No.	G.L.		Strut Elev.	FoS for toe elev. = 40.75		Toe elev. for FoS = 1.500		Direction of failure
	Act.	Pass.		Factor of Safety	Moment at elev.	Toe elev.	Wall Penetration	
1	49.75	49.75	Cant.	Conditions not suitable for FoS calc.				
2	49.75	49.75	Cant.	Conditions not suitable for FoS calc.				
3	49.75	47.80	Cant.	2.237	41.81	42.43	5.37	L to R
4	49.75	47.80		No analysis at this stage				
5	49.75	47.80	48.10	Conditions not suitable for FoS calc.				
6	49.75	43.65	48.10	2.102	n/a	42.58	1.07	L to R
7	49.75	43.65		No analysis at this stage				

All remaining stages have more than one strut - FoS calculation n/a

PILEDESIGNS LTD
 Program: WALLAP Version 6.06 Revision A51.B69.R54
 Licensed from GEOSOLVE
 Data filename/Run ID: Hampstead_Wall_5_450mm_rev_01_SLS
 Hampstead - 24-26 Redington Gardens
 Wall 5, Secant-SLS, 450 dia @ 650 - run 01

Sheet No.
 Job No. 21495
 Made by : DBS
 Date: 1-10-2018
 Checked :

Units: kN,m

Summary of results

BENDING MOMENT and DISPLACEMENT ANALYSIS of Fully Embedded Wall

Analysis options

Length of wall perpendicular to section = 50.00m
 Subgrade reaction model - Boussinesq Influence coefficients
 Soil deformations are elastic until the active or passive limit is reached
 Open Tension Crack analysis - No

Rigid boundaries: Left side 50.00 from wall
 Right side 50.00 from wall

Limit State: Serviceability Limit State

Calculated Bending Moments and Strut Forces have been multiplied by a factor of 1.35 to obtain values for structural design.

Bending moment, shear force and displacement envelopes

Node no.	Y coord	Displacement		Bending moment				Shear force			
		max. m	min. m	Calculated kN.m/m		Factored kN.m/m		Calculated kN/m		Factored kN/m	
1	49.75	0.013	0.000	0	-0	0	-0	0	0	0	0
2	49.40	0.012	0.000	1	0	1	0	4	-1	6	-1
3	49.08	0.011	0.000	3	-0	4	-1	14	-2	18	-3
4	48.75	0.010	0.000	9	-1	12	-2	23	-2	32	-3
5	48.42	0.009	0.000	18	-2	25	-2	32	-2	43	-2
6	48.10	0.008	0.000	30	-2	40	-3	39	-83	53	-113
7	47.80	0.009	0.000	14	-2	18	-3	22	-77	30	-103
8	47.50	0.009	0.000	21	-17	29	-22	27	-69	37	-93
9	47.00	0.010	0.000	35	-47	48	-64	28	-53	38	-72
10	46.50	0.010	0.000	48	-69	64	-93	21	-34	28	-46
11	46.00	0.010	0.000	55	-80	75	-108	6	-12	8	-17
12	45.50	0.010	0.000	55	-80	74	-107	23	-9	31	-12
13	45.00	0.009	0.000	48	-67	65	-90	53	-18	71	-24
14	44.50	0.008	0.000	37	-44	50	-59	85	-22	115	-30
15	44.17	0.007	0.000	30	-25	41	-34	108	-22	145	-30
16	43.85	0.006	0.000	57	-3	77	-4	132	-87	178	-118
17	43.65	0.006	0.000	42	0	56	0	78	-72	105	-97
18	43.33	0.006	0.000	36	0	49	0	45	-49	60	-66
19	43.00	0.005	0.000	45	0	61	0	16	-31	21	-42
20	42.50	0.005	0.000	42	0	57	0	0	-20	0	-26
21	42.00	0.004	0.000	29	-1	39	-2	0	-29	0	-39
22	41.50	0.004	0.000	13	-2	18	-2	4	-28	5	-37
23	41.13	0.003	0.000	4	-1	6	-1	2	-18	3	-24
24	40.75	0.003	0.000	0	-0	0	-0	0	0	0	0

Summary of results (continued)

Calculated Bending Moments and Strut Forces have been multiplied by a factor of 1.35 to obtain values for structural design.

Maximum and minimum bending moment and shear force at each stage

Stage no.	Bending moment						Shear force							
	Calculated		Factored		Calculated		Factored		Calculated		Factored			
min.	max. elev.	min. elev.	max. elev.	min. elev.	max. elev.	min. elev.	max. elev.	min. elev.	max. elev.	min. elev.	max. elev.	min. elev.	max. elev.	
	kN.m/m		kN.m/m		kN.m/m		kN/m		kN/m		kN/m		kN/m	
1	43.33	-3	46.50	2	-4	3	45.00	-1	48.10	4				
-2	44.17	-2	48.10	5	-3	4	47.50	-2	48.75	5				
-3	55	46.00	-0	41.13	75	-0	28	47.00	-22	44.50	38			
-30	No calculation at this stage													
4	47	45.50	-0	49.75	64	-0	22	47.00	-18	44.17	30			
-24	44	43.00	-80	46.00	60	-108	78	43.65	-83	48.10	105			
-113	No calculation at this stage													
7	45	43.00	-75	46.00	61	-102	74	43.85	-81	48.10	100			
-109	57	43.85	-69	46.00	77	-93	132	43.85	-87	43.85	178			
-118	No calculation at this stage													
10	38	43.85	-74	46.00	51	-99	125	43.85	-80	48.10	168			
-108														

Maximum and minimum displacement at each stage

Stage no.	Displacement				Stage description
	maximum elev.	minimum elev.	maximum elev.	minimum elev.	
	m		m		
1	0.001	47.80	0.000	49.75	Apply surcharge no.1 at elev. 49.75
2	0.001	49.75	0.000	49.75	Apply water pressure profile no.1
3	0.013	49.75	0.000	49.75	Excav. to elev. 47.80 on RIGHT side
4	No calculation at this stage				Install strut no.1 at elev. 48.10
5	0.013	49.75	0.000	49.75	Apply water pressure profile no.2
6	0.010	46.50	0.000	49.75	Excav. to elev. 43.65 on RIGHT side
7	No calculation at this stage				Install strut no.2 at elev. 43.85
8	0.010	46.00	0.000	49.75	Change EI of wall to 43355kN.m ² /m run
9	0.010	46.50	0.000	49.75	Change soil type 3 to soil type 4
10	No calculation at this stage				Apply surcharge no.2 at elev. 43.65
11	0.010	46.00	0.000	49.75	Apply water pressure profile no.3

Strut forces at each stage (horizontal components)

Stage no.	Strut no. 1			Strut no. 2		
	at elev. 48.10			at elev. 43.85		
	Calculated	Factored	Calculated	Factored	Calculated	Factored
	kN per m run	kN per strut	kN per strut	kN per m run	kN per strut	kN per strut
5	7	7	10	---	---	---
6	121	121	164	---	---	---
8	120	120	162	16	16	21
9	116	116	157	219	219	296
11	119	119	161	172	172	233

Units: kN,m

Bending moment, shear force, displacement envelopes

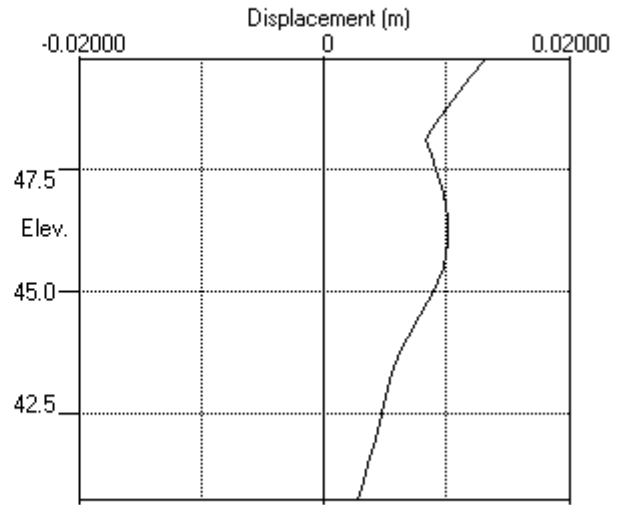
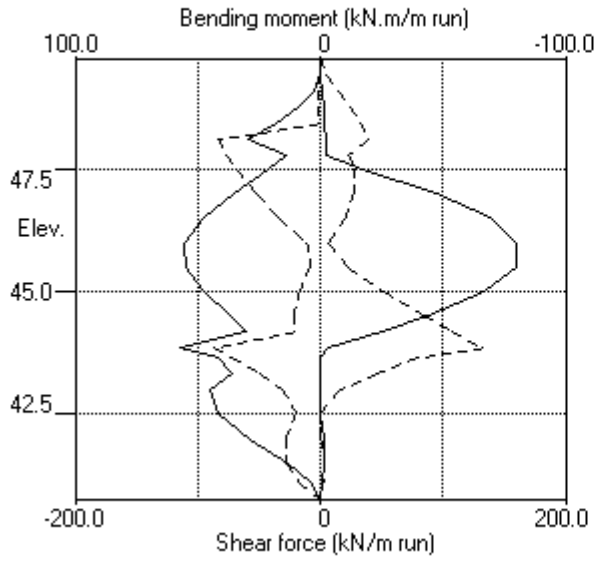



WALLAP

6-ULS1

PILEDESIGNS LTD
 Program: WALLAP Version 6.06 Revision A51.B69.R54
 Licensed from GEOSOLVE
 Data filename/Run ID: Hampstead_Wall_6_450mm_rev_02_ULS1
 Hampstead - 24-26 Redington Gardens
 Wall 6, Secant-ULS1, 450 dia @ 650 - run 02

Sheet No.
 Job No. 21495
 Made by : DBS
 Date:30-11-2018
 Checked :

Units: kN,m

INPUT DATA

SOIL PROFILE

Stratum no.	Elevation of top of stratum	Soil types	
		Left side	Right side
1	49.75	1 Made Ground dr	1 Made Ground dr
2	47.50	2 Claygate Clay dr	2 Claygate Clay dr
3	45.00	3 London Clay und	3 London Clay und

SOIL PROPERTIES (Unfactored SLS soil strengths)

No. Description	Bulk density kN/m3	Young's Modulus Eh,kN/m2	At rest coeff. Ko	Consol state. NC/OC	Active limit Ka	Passive limit Kp	Cohesion kN/m2
(Datum elev.)		(dEh/dy)	(dKo/dy)	(Nu)	(Kac)	(Kpc)	(dc/dy)
1 Made Ground dr	18.00	10000	0.530	OC (0.250)	0.337 (0.000)	3.442 (0.000)	
2 Claygate Clay dr	19.00	30000	1.000	NC (0.200)	0.323 (1.330)	3.647 (5.195)	0.0d
3 London Cl.. (45.00)	20.00	40000 (4000)	1.000	OC (0.490)	1.000 (2.476)	1.000 (2.390)	50.00u (5.000)
4 London Cl.. (45.00)	20.00	30800 (3080)	1.000	OC (0.200)	0.351 (1.391)	3.253 (4.831)	0.0d

Additional soil parameters associated with Ka and Kp

No. Description	--- parameters for Ka ---			--- parameters for Kp ---		
	Soil friction angle	Wall adhesion coeff.	Back-fill angle	Soil friction angle	Wall adhesion coeff.	Back-fill angle
1 Made Ground dr	26.00	0.670	0.00	26.00	0.500	0.00
2 Claygate Clay dr	27.00	0.670	0.00	27.00	0.500	0.00
3 London Clay und	0.00	0.670	0.00	0.00	0.500	0.00
4 London Clay dr	25.00	0.670	0.00	25.00	0.500	0.00

GROUND WATER CONDITIONS

Density of water = 9.810 kN/m3

	Left side	Right side
Initial water table elevation	49.40	49.40

Automatic water pressure balancing at toe of wall : No

Water profile no.	Left side			Right side		
	Point no.	Elev. m	Piezo elev. m	Point no.	Elev. m	Piezo elev. m
1	1	49.40	49.40	1	47.50	47.50
2	1	49.40	49.40	1	43.00	43.00
3	1	49.40	49.40	1	43.65	43.65
				2	43.65	49.40

WALL PROPERTIES

Type of structure = Fully Embedded Wall
 Elevation of toe of wall = 39.75
 Maximum finite element length = 0.60 m
 Youngs modulus of wall E = 1.9600E+07 kN/m2
 Moment of inertia of wall I = 3.0968E-03 m4/m run
 E.I = 60696 kN.m2/m run
 Yield Moment of wall = Not defined

STRUTS and ANCHORS

Strut/ anchor no.	Elev.	Strut spacing m	X-section area of strut sq.m	Youngs modulus kN/m2	Free length m	Inclin -ation (degs)	Pre- stress /strut kN	Tension allowed
1	48.40	1.00	0.300000	1.400E+07	5.00	0.00	0	No
2	43.85	1.00	0.300000	1.400E+07	5.00	0.00	0	No

SURCHARGE LOADS

Surch -arge no.	Elev.	Distance from wall	Length parallel to wall	Width perpend. to wall	Surcharge ----- kN/m2 ----- Near edge Far edge		Equiv. soil type	Partial factor/ Category
1	49.75	0.50(L)	10.00	0.60	6.50	=	N/A	1.00 P/U
2	49.50	1.10(L)	10.00	0.50	50.00	=	N/A	1.00 P/U
3	49.75	1.60(L)	10.00	5.00	6.50	=	N/A	1.00 P/U
4	49.75	0.50(L)	10.00	0.60	5.00	=	N/A	1.10 Var
5	49.50	1.10(L)	10.00	0.50	40.00	=	N/A	1.10 Var
6	49.75	1.60(L)	10.00	5.00	5.00	=	N/A	1.10 Var
7	43.65	-0.00(R)	10.00	10.00	57.00	=	N/A	1.00 P/F

Note: L = Left side, R = Right side

Limit State Categories P/U = Permanent Unfavourable

P/F = Permanent Favourable

Var = Variable (unfavourable)

CONSTRUCTION STAGES

Construction stage no.	Stage description -----
1	Apply surcharge no.1 at elevation 49.75
2	Apply surcharge no.2 at elevation 49.50 No analysis at this stage
3	Apply surcharge no.3 at elevation 49.75 No analysis at this stage
4	Change EI of wall to 60696 kN.m2/m run Yield moment not defined Reset wall displacements to zero at this stage
5	Apply surcharge no.4 at elevation 49.75 No analysis at this stage
6	Apply surcharge no.5 at elevation 49.50 No analysis at this stage
7	Apply surcharge no.6 at elevation 49.75 No analysis at this stage
8	Apply water pressure profile no.1 (Mod. Conserv.)
9	Excavate to elevation 48.10 on RIGHT side
10	Install strut or anchor no.1 at elevation 48.40
11	Apply water pressure profile no.2 (Mod. Conserv.)
12	Excavate to elevation 43.17 on RIGHT side
13	Fill to elevation 43.65 on RIGHT side with soil type 1
14	Install strut or anchor no.2 at elevation 43.85
15	Change EI of wall to 43355 kN.m2/m run Yield moment not defined Allow wall to relax with new modulus value
16	Change properties of soil type 3 to soil type 4 Ko pressures will not be reset
17	Apply surcharge no.7 at elevation 43.65 No analysis at this stage
18	Apply water pressure profile no.3 (Mod. Conserv.)

FACTORS OF SAFETY and ANALYSIS OPTIONS

Limit State options: ULS DA1 Combination 1
Water pressures : Moderately Conservative
Partial factor on C' = 1.000
Partial factor on Phi' = 1.000
Partial factor on Cu = 1.000
Partial factor on Soil Modulus = 1.000
Partial factor on Permanent Unfavourable loads = 1.000
Partial factor on Permanent Favourable loads = 1.000
Partial factor on Variable Unfavourable loads = 1.100
Design factor on calculated Bending Moments = 1.350

Parameters for undrained strata:

Minimum equivalent fluid density = 5.00 kN/m3
Maximum depth of water filled tension crack = 0.00 m

Bending moment and displacement calculation:

Method - Subgrade reaction model using Influence Coefficients
Open Tension Crack analysis? - No
Non-linear Modulus Parameter (L) = 10.00 m

Boundary conditions:

Length of wall (normal to plane of analysis) = 50.00 m

Width of excavation on Left side of wall = 50.00 m

Width of excavation on Right side of wall = 50.00 m

Distance to rigid boundary on Left side = 50.00 m

Distance to rigid boundary on Right side = 50.00 m

OUTPUT OPTIONS

Stage no.	Stage description	Displacement Bending mom. Shear force	Active, Passive pressures	Graph. output
1	Apply surcharge no.1 at elev. 49.75	No	No	No
2	Apply surcharge no.2 at elev. 49.50	Yes	Yes	Yes
3	Apply surcharge no.3 at elev. 49.75	Yes	Yes	Yes
4	Change EI of wall to 60696kN.m2/m run	Yes	Yes	Yes
5	Apply surcharge no.4 at elev. 49.75	Yes	Yes	Yes
6	Apply surcharge no.5 at elev. 49.50	Yes	Yes	Yes
7	Apply surcharge no.6 at elev. 49.75	Yes	Yes	Yes
8	Apply water pressure profile no.1	Yes	Yes	Yes
9	Excav. to elev. 48.10 on RIGHT side	Yes	Yes	Yes
10	Install strut no.1 at elev. 48.40	Yes	Yes	Yes
11	Apply water pressure profile no.2	Yes	Yes	Yes
12	Excav. to elev. 43.17 on RIGHT side	Yes	Yes	Yes
13	Fill to elev. 43.65 on RIGHT side	Yes	Yes	Yes
14	Install strut no.2 at elev. 43.85	Yes	Yes	Yes
15	Change EI of wall to 43355kN.m2/m run	No	No	No
16	Change soil type 3 to soil type 4	No	No	No
17	Apply surcharge no.7 at elev. 43.65	No	No	No
18	Apply water pressure profile no.3	No	No	No
*	Summary output	Yes	-	Yes

Units: kN,m

Stage No.18 Apply water pressure profile no.3 (Mod. Conserv.)

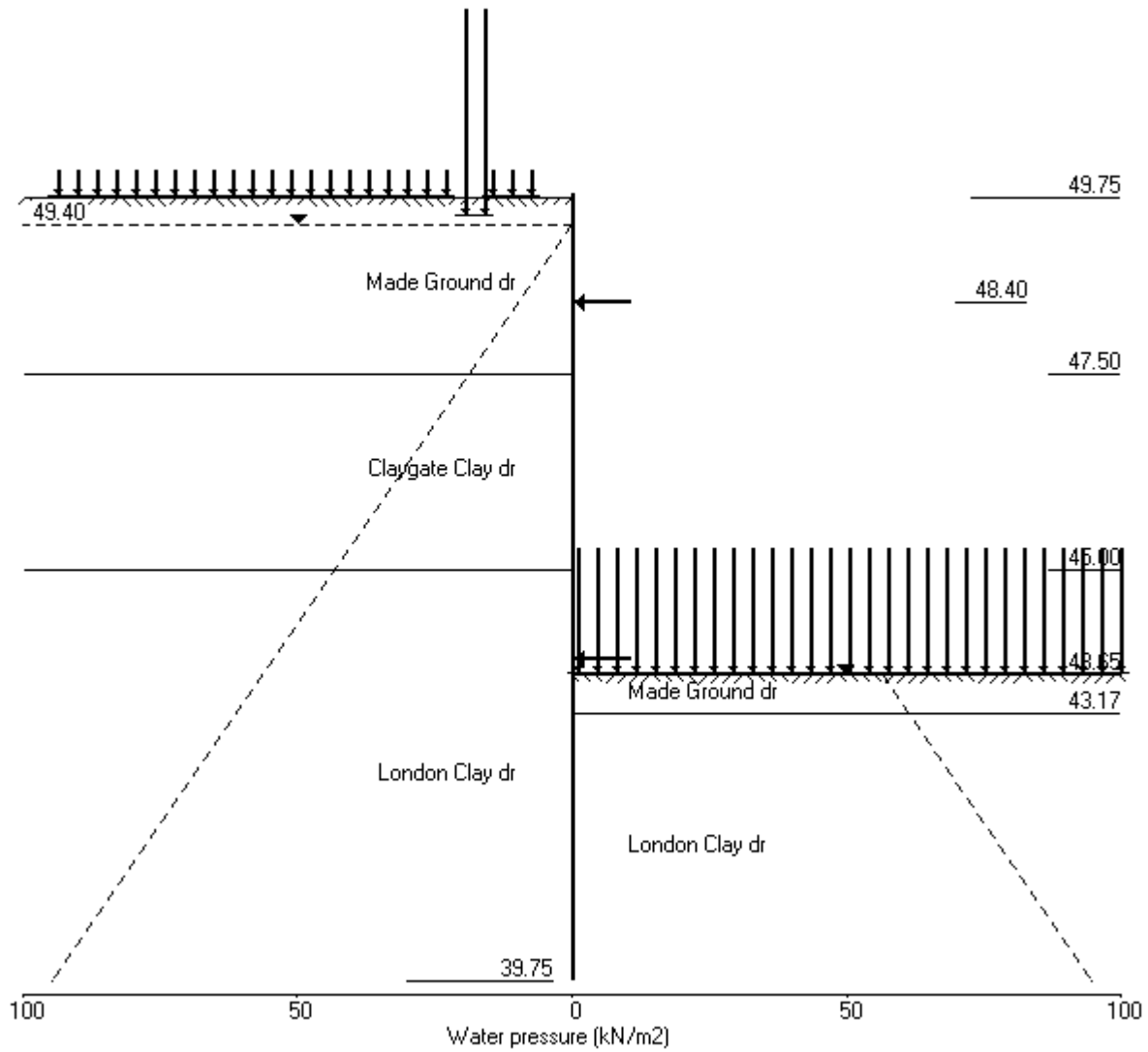

PILEDESIGNS LTD
 Program: WALLAP Version 6.06 Revision A51.B69.R54
 Licensed from GEOSOLVE
 Data filename/Run ID: Hampstead_Wall_6_450mm_rev_02_ULS1
 Hampstead - 24-26 Redington Gardens
 Wall 6, Secant-ULS1, 450 dia @ 650 - run 02

Sheet No.
 Job No. 21495
 Made by : DBS
 Date:30-11-2018
 Checked :

Units: kN,m

Stage No. 9 Excavate to elevation 48.10 on RIGHT side

BENDING MOMENT and DISPLACEMENT ANALYSIS of Fully Embedded Wall

Analysis options

Length of wall perpendicular to section = 50.00m
 Subgrade reaction model - Boussinesq Influence coefficients
 Soil deformations are elastic until the active or passive limit is reached
 Open Tension Crack analysis - No

Rigid boundaries: Left side 50.00 from wall
 Right side 50.00 from wall

Limit State: ULS DA1 Combination 1

Calculated Bending Moments and Strut Forces are to be multiplied by a factor of 1.35 to obtain values for structural design. See summary for factored values.

*** Wall displacements reset to zero at stage 4

Node no.	Y coord	Nett pressure kN/m2	Wall disp. m	Wall rotation rad.	Shear force kN/m	Bending moment kN.m/m	Strut forces kN/m	EI of wall kN.m2/m
1	49.75	0.00	0.010	2.40E-03	0.0	0.0		60696
2	49.50	1.67	0.010	2.40E-03	0.2	0.1		60696
3	49.40	2.46	0.009	2.40E-03	0.4	0.1		60696
4	48.90	10.67	0.008	2.39E-03	3.7	1.0		60696
5	48.40	19.46	0.007	2.37E-03	11.2	4.5		60696
6	48.10	24.32	0.006	2.33E-03	17.8	8.8		60696
7	47.50	5.07	0.005	2.17E-03	26.6	23.6		60696
		-7.09	0.005	2.17E-03	26.6	23.6		
8	47.15	-17.67	0.004	2.01E-03	22.3	32.2		60696
9	46.80	-27.71	0.004	1.80E-03	14.3	39.2		60696
10	46.20	-23.18	0.003	1.39E-03	-0.9	43.5		60696
11	45.60	-9.42	0.002	9.87E-04	-10.7	38.7		60696
12	45.00	-1.17	0.001	6.46E-04	-13.9	30.5		60696
		-4.37	0.001	6.46E-04	-13.9	30.5		
13	44.42	2.71	0.001	4.02E-04	-14.4	21.7		60696
14	43.85	5.66	0.001	2.37E-04	-12.0	13.8		60696
15	43.65	6.00	0.001	1.97E-04	-10.8	11.5		60696
16	43.17	5.89	0.001	1.27E-04	-7.9	7.0		60696
17	43.00	5.63	0.001	1.10E-04	-7.0	5.7		60696
18	42.50	4.52	0.001	7.73E-05	-4.4	2.9		60696
19	42.00	3.24	0.001	6.22E-05	-2.5	1.2		60696
20	41.40	1.85	0.001	5.63E-05	-1.0	0.3		60696
21	40.80	0.78	0.001	5.58E-05	-0.2	-0.0		60696
22	40.28	0.11	0.001	5.63E-05	0.1	-0.0		60696
23	39.75	-0.37	0.001	5.65E-05	0.0	-0.0		---

Node no.	Y coord	LEFT side					Total earth pressure kN/m2	Coeff. of subgrade reaction kN/m3
		Effective stresses						
		Water press. kN/m2	Vertic-al kN/m2	Active limit kN/m2	Passive limit kN/m2	Earth pressure kN/m2		
1	49.75	0.00	0.00	0.00	0.00	0.00	3615	
2	49.50	0.00	4.95	1.67	17.03	1.67a	3615	
3	49.40	0.00	7.30	2.46	25.12	2.46a	3615	
4	48.90	4.90	17.13	5.77	58.96	10.67a	3615	
5	48.40	9.81	28.68	9.65	98.72	19.46a	3615	
6	48.10	12.75	34.36	11.57	118.26	24.32a	3615	
7	47.50	18.64	42.32	14.25	145.69	32.89a	3615	
		18.64	42.32	13.65	154.35	32.29a	10443	

(continued)

Stage No.9 Excavate to elevation 48.10 on RIGHT side

Node no.	Y coord	LEFT side					Total earth pressure	Coeff. of subgrade reaction
		Water press.	Vertic -al	Effective Active limit	Effective Passive limit	Earth pressure		
		kN/m2	kN/m2	kN/m2	kN/m2	kN/m2	kN/m2	kN/m3
8	47.15	22.07	45.92	14.81	167.45	14.81	36.88a	10443
9	46.80	25.51	48.94	15.79	178.47	16.50	42.00	10443
10	46.20	31.39	53.43	17.23	194.84	30.35	61.74	10443
11	45.60	37.28	57.55	18.56	209.87	41.22	78.50	10443
12	45.00	43.16	61.58	19.87	224.59	49.68	92.84	10443
		Total>	104.75	23.75m	224.26	80.89	80.89	19936
13	44.42	Total>	114.87	26.63m	241.25	94.97	94.97	21083
14	43.85	Total>	125.07	29.50m	258.32	107.27	107.27	22229
15	43.65	Total>	128.64	30.50m	264.28	111.26	111.26	22628
16	43.17	Total>	137.26	32.90m	278.64	120.43	120.43	23585
17	43.00	Total>	140.33	33.75m	283.74	123.59	123.59	23923
18	42.50	Total>	149.41	36.25m	298.80	132.73	132.73	24920
19	42.00	Total>	158.57	38.75m	313.94	141.81	141.81	25917
20	41.40	Total>	169.66	41.75m	332.20	152.79	152.79	27113
21	40.80	Total>	180.84	44.75m	350.55	163.95	163.95	28309
22	40.28	Total>	190.70	47.37m	366.68	173.87	173.87	29356
23	39.75	Total>	200.61	50.00m	382.87	183.90	183.90	30403

Node no.	Y coord	RIGHT side					Total earth pressure	Coeff. of subgrade reaction
		Water press.	Vertic -al	Effective Active limit	Effective Passive limit	Earth pressure		
		kN/m2	kN/m2	kN/m2	kN/m2	kN/m2	kN/m2	kN/m3
1	49.75	0.00	0.00	0.00	0.00	0.00	0.00	0.0
2	49.50	0.00	0.00	0.00	0.00	0.00	0.00	0.0
3	49.40	0.00	0.00	0.00	0.00	0.00	0.00	0.0
4	48.90	0.00	0.00	0.00	0.00	0.00	0.00	0.0
5	48.40	0.00	0.00	0.00	0.00	0.00	0.00	0.0
6	48.10	0.00	0.00	0.00	0.00	0.00	0.00	0.0
		0.00	0.00	0.00	0.00	0.00	0.00	4808
7	47.50	0.00	10.80	3.64	37.18	27.82	27.82	4808
		0.00	10.80	3.48	39.39	39.39	39.39p	13916
8	47.15	3.43	14.02	4.52	51.12	51.12	54.55p	13916
9	46.80	6.87	17.23	5.56	62.85	62.85	69.71p	13916
10	46.20	12.75	22.75	7.34	82.96	72.17	84.92	13916
11	45.60	18.64	28.26	9.12	103.07	69.28	87.92	13916
12	45.00	24.52	33.78	10.90	123.18	69.49	94.01	13916
		Total>	58.30	15.50m	177.81	85.27	85.27	26132
13	44.42	Total>	69.80	18.37m	196.18	92.26	92.26	27635
14	43.85	Total>	81.31	21.25m	214.56	101.61	101.61	29137
15	43.65	Total>	85.31	22.25m	220.95	105.26	105.26	29660
16	43.17	Total>	94.91	24.65m	236.29	114.54	114.54	30914
17	43.00	Total>	98.31	25.50m	241.72	117.96	117.96	31359
18	42.50	Total>	108.32	28.00m	257.70	128.21	128.21	32665
19	42.00	Total>	118.32	30.50m	273.68	138.57	138.57	33972
20	41.40	Total>	130.33	33.50m	292.86	150.94	150.94	35540
21	40.80	Total>	142.34	36.50m	312.04	163.17	163.17	37108
22	40.28	Total>	152.85	39.12m	328.83	173.76	173.76	38480
23	39.75	Total>	163.36	41.75m	345.61	184.26	184.26	39852

Note: 36.88a Soil pressure at active limit
69.71p Soil pressure at passive limit

Units: kN,m

Stage No.9 Excav. to elev. 48.10 on RIGHT side

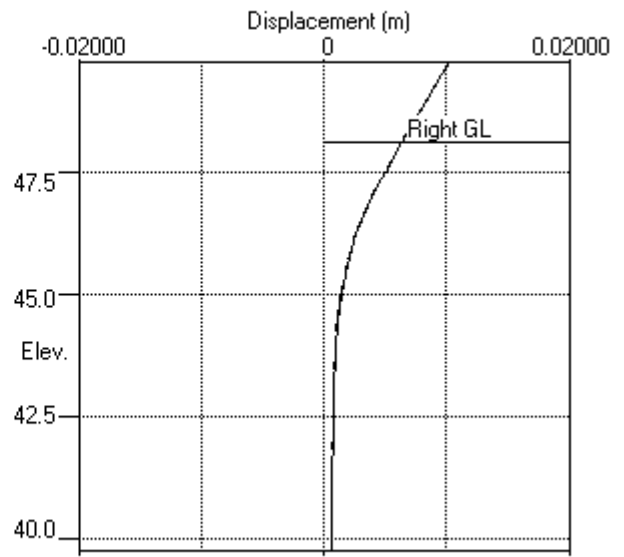
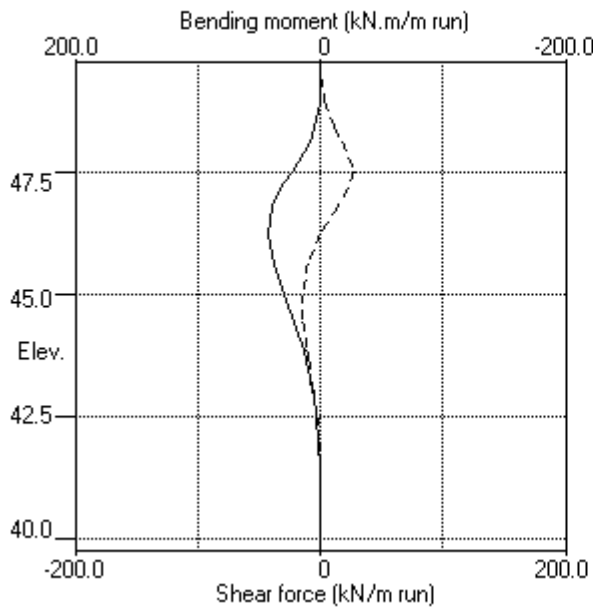

Stage No.9 Excav. to elev. 48.10 on RIGHT side

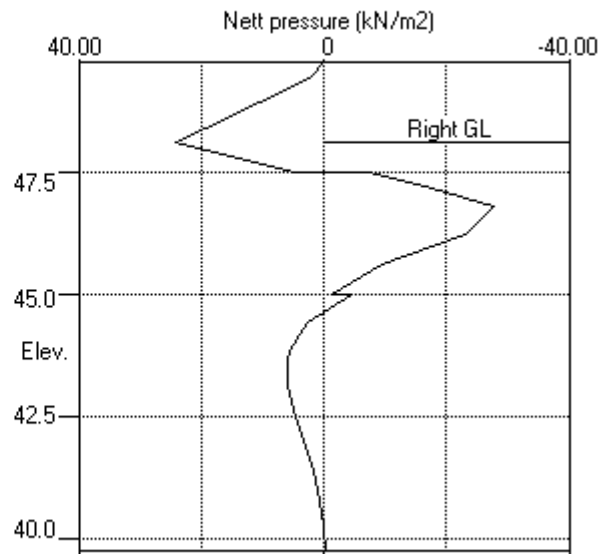
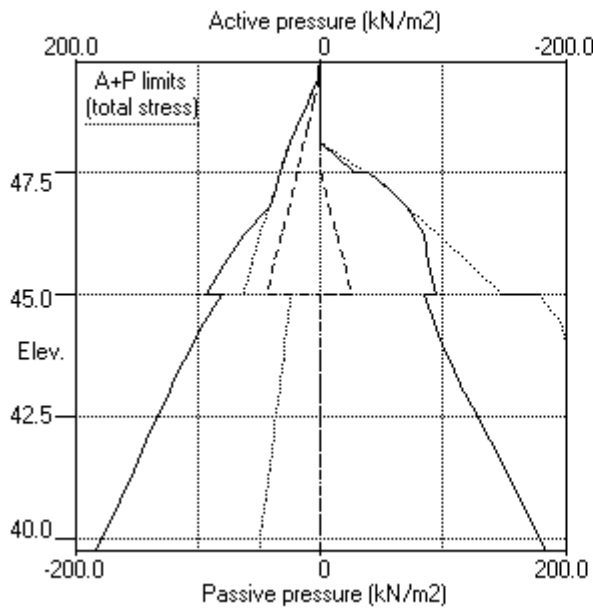

PILEDESIGNS LTD
 Program: WALLAP Version 6.06 Revision A51.B69.R54
 Licensed from GEOSOLVE
 Data filename/Run ID: Hampstead_Wall_6_450mm_rev_02_ULS1
 Hampstead - 24-26 Redington Gardens
 Wall 6, Secant-ULS1, 450 dia @ 650 - run 02

Sheet No.
 Job No. 21495
 Made by : DBS
 Date:30-11-2018
 Checked :

Units: kN,m

Stage No. 12 Excavate to elevation 43.17 on RIGHT side

BENDING MOMENT and DISPLACEMENT ANALYSIS of Fully Embedded Wall

Analysis options

Length of wall perpendicular to section = 50.00m
 Subgrade reaction model - Boussinesq Influence coefficients
 Soil deformations are elastic until the active or passive limit is reached
 Open Tension Crack analysis - No

Rigid boundaries: Left side 50.00 from wall
 Right side 50.00 from wall

Limit State: ULS DA1 Combination 1

Calculated Bending Moments and Strut Forces are to be multiplied by a factor of 1.35 to obtain values for structural design. See summary for factored values.

*** Wall displacements reset to zero at stage 4

Node no.	Y coord	Nett pressure kN/m2	Wall disp. m	Wall rotation rad.	Shear force kN/m	Bending moment kN.m/m	Strut forces kN/m	EI of wall kN.m2/m
1	49.75	0.00	0.003	-2.98E-03	0.0	0.0		60696
2	49.50	17.03	0.004	-2.98E-03	2.1	0.2		60696
3	49.40	25.12	0.004	-2.98E-03	4.2	0.5		60696
4	48.90	29.44	0.006	-3.00E-03	17.9	5.2		60696
5	48.40	19.46	0.007	-3.10E-03	30.1	18.2	126.9	60696
		19.46	0.007	-3.10E-03	-96.8	18.2		
6	48.10	24.32	0.008	-3.12E-03	-90.2	-9.9		60696
7	47.50	32.89	0.010	-2.79E-03	-73.1	-58.2		60696
		32.29	0.010	-2.79E-03	-73.1	-58.2		
8	47.15	36.88	0.011	-2.39E-03	-61.0	-81.7		60696
9	46.80	41.29	0.012	-1.86E-03	-47.3	-100.3		60696
10	46.20	48.63	0.012	-7.80E-04	-20.3	-120.2		60696
11	45.60	55.84	0.013	4.25E-04	11.0	-124.1		60696
12	45.00	63.03	0.012	1.57E-03	46.7	-107.6		60696
		23.75	0.012	1.57E-03	46.7	-107.6		
13	44.42	26.63	0.011	2.45E-03	61.2	-77.2		60696
14	43.85	29.50	0.009	2.99E-03	77.3	-37.8		60696
15	43.65	30.50	0.009	3.09E-03	83.3	-21.8		60696
16	43.17	32.90	0.007	3.10E-03	98.5	21.7		60696
		-108.47	0.007	3.10E-03	98.5	21.7		
17	43.00	-108.99	0.007	3.02E-03	80.0	37.3		60696
18	42.50	-97.98	0.005	2.60E-03	28.3	63.4		60696
19	42.00	-62.82	0.004	2.05E-03	-11.9	70.5		60696
20	41.40	-19.23	0.003	1.45E-03	-36.5	52.0		60696
21	40.80	13.12	0.002	1.06E-03	-38.4	26.6		60696
22	40.28	36.65	0.002	9.15E-04	-25.3	8.3		60696
23	39.75	59.69	0.001	8.80E-04	0.0	-0.0		---

At elev. 48.40 Strut force = 126.9 kN/strut = 126.9 kN/m run

Node no.	Y coord	LEFT side					Total earth pressure kN/m2	Coeff. of subgrade reaction kN/m3
		Water press. kN/m2	Vertical limit kN/m2	Active limit kN/m2	Passive limit kN/m2	Earth pressure kN/m2		
1	49.75	0.00	0.00	0.00	0.00	0.00	0.00	7314
2	49.50	0.00	4.95	1.67	17.03	17.03	17.03p	7314
3	49.40	0.00	7.30	2.46	25.12	25.12	25.12p	7314
4	48.90	4.90	17.13	5.77	58.96	24.53	29.44	7314
5	48.40	9.81	28.68	9.65	98.72	9.65	19.46a	2167

(continued)

Stage No.12 Excavate to elevation 43.17 on RIGHT side

Node no.	Y coord	LEFT side					Total earth pressure	Coeff. of subgrade reaction
		Water press.	Vertic -al	Effective Active limit	Effective Passive limit	Earth pressure		
		kN/m2	kN/m2	kN/m2	kN/m2	kN/m2	kN/m2	kN/m3
6	48.10	12.75	34.36	11.57	118.26	11.57	24.32a	2167
7	47.50	18.64	42.32	14.25	145.69	14.25	32.89a	2167
		18.64	42.32	13.65	154.35	13.65	32.29a	6231
8	47.15	22.07	45.92	14.81	167.45	14.81	36.88a	6231
9	46.80	25.51	48.94	15.79	178.47	15.79	41.29a	6231
10	46.20	31.39	53.43	17.23	194.84	17.23	48.63a	6231
11	45.60	37.28	57.55	18.56	209.87	18.56	55.84a	6231
12	45.00	43.16	61.58	19.87	224.59	19.87	63.03a	6231
		Total>	104.75	23.75m	224.26	23.75	23.75a	12486
13	44.42	Total>	114.87	26.63m	241.25	26.63	26.63a	13204
14	43.85	Total>	125.07	29.50m	258.32	29.50	29.50a	13921
15	43.65	Total>	128.64	30.50m	264.28	30.50	30.50a	14171
16	43.17	Total>	137.26	32.90m	278.64	32.90	32.90a	14771
17	43.00	Total>	140.33	33.75m	283.74	37.80	37.80	14983
18	42.50	Total>	149.41	36.25m	298.80	64.80	64.80	15607
19	42.00	Total>	158.57	38.75m	313.94	89.61	89.61	16231
20	41.40	Total>	169.66	41.75m	332.20	115.36	115.36	16980
21	40.80	Total>	180.84	44.75m	350.55	137.47	137.47	17730
22	40.28	Total>	190.70	47.37m	366.68	155.31	155.31	18385
23	39.75	Total>	200.61	50.00m	382.87	173.04	173.04	19041

Node no.	Y coord	RIGHT side					Total earth pressure	Coeff. of subgrade reaction
		Water press.	Vertic -al	Effective Active limit	Effective Passive limit	Earth pressure		
		kN/m2	kN/m2	kN/m2	kN/m2	kN/m2	kN/m2	kN/m3
1	49.75	0.00	0.00	0.00	0.00	0.00	0.00	0.0
2	49.50	0.00	0.00	0.00	0.00	0.00	0.00	0.0
3	49.40	0.00	0.00	0.00	0.00	0.00	0.00	0.0
4	48.90	0.00	0.00	0.00	0.00	0.00	0.00	0.0
5	48.40	0.00	0.00	0.00	0.00	0.00	0.00	0.0
6	48.10	0.00	0.00	0.00	0.00	0.00	0.00	0.0
7	47.50	0.00	0.00	0.00	0.00	0.00	0.00	0.0
8	47.15	0.00	0.00	0.00	0.00	0.00	0.00	0.0
9	46.80	0.00	0.00	0.00	0.00	0.00	0.00	0.0
10	46.20	0.00	0.00	0.00	0.00	0.00	0.00	0.0
11	45.60	0.00	0.00	0.00	0.00	0.00	0.00	0.0
12	45.00	0.00	0.00	0.00	0.00	0.00	0.00	0.0
13	44.42	0.00	0.00	0.00	0.00	0.00	0.00	0.0
14	43.85	0.00	0.00	0.00	0.00	0.00	0.00	0.0
15	43.65	0.00	0.00	0.00	0.00	0.00	0.00	0.0
16	43.17	0.00	0.00	0.00	0.00	0.00	0.00	0.0
		Total>	0.00	0.00	141.37	141.37	141.37p	30521
17	43.00	Total>	3.40	0.85m	146.80	146.80	146.80p	30960
18	42.50	Total>	13.40	3.35m	162.77	162.77	162.77p	32250
19	42.00	Total>	23.40	5.85m	178.75	152.43	152.43	33540
20	41.40	Total>	35.40	8.85m	197.92	134.58	134.58	35088
21	40.80	Total>	47.41	11.85m	217.10	124.35	124.35	36636
22	40.28	Total>	57.91	14.47m	233.88	118.66	118.66	37991
23	39.75	Total>	68.42	17.10m	250.66	113.36	113.36	39345

Note: 32.90a Soil pressure at active limit
162.77p Soil pressure at passive limit

Units: kN,m

Stage No.12 Excav. to elev. 43.17 on RIGHT side

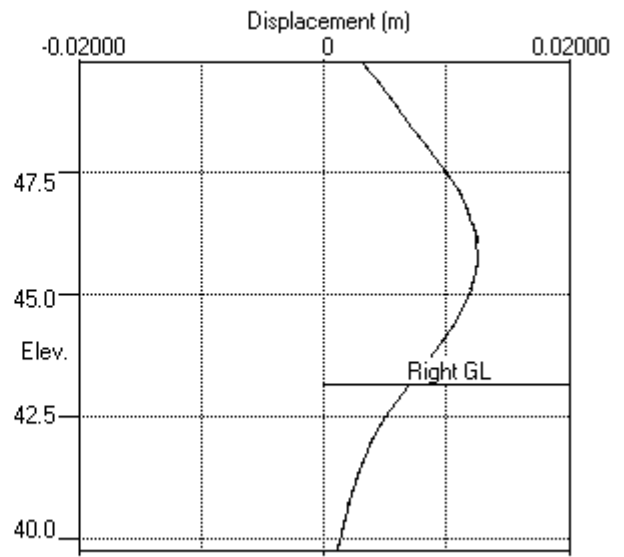
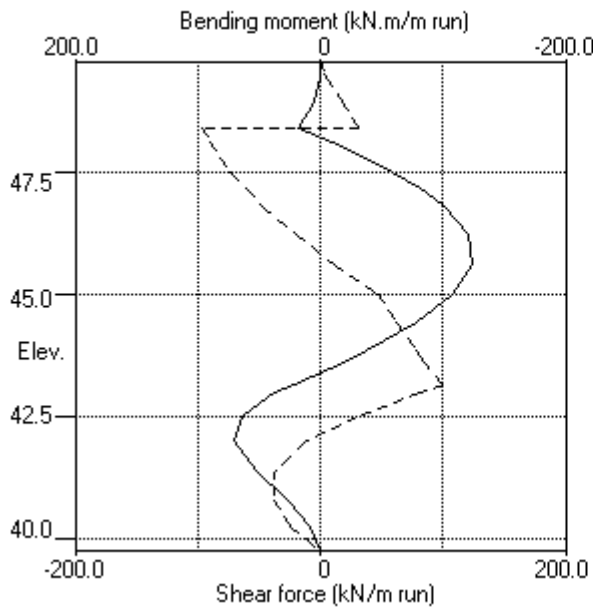

Stage No.12 Excav. to elev. 43.17 on RIGHT side

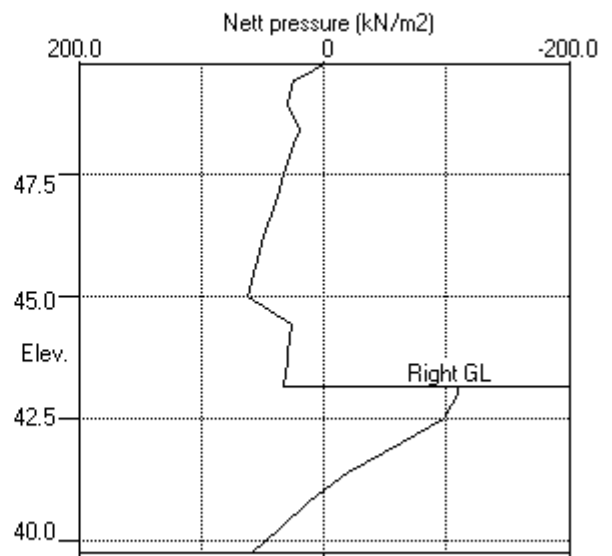
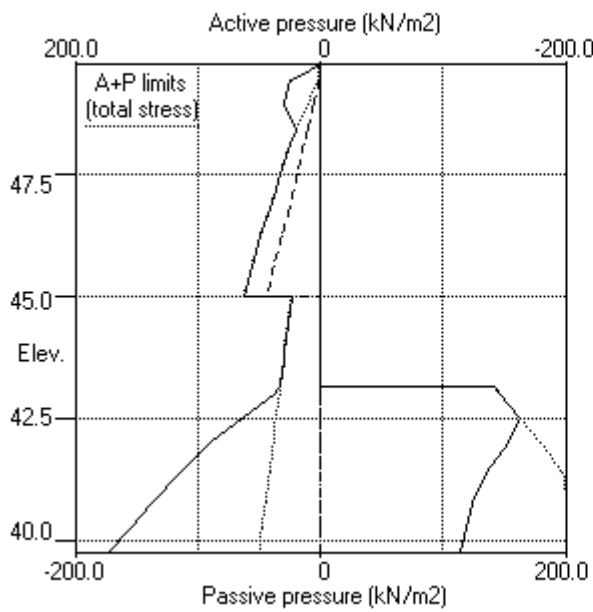

PILEDESIGNS LTD
 Program: WALLAP Version 6.06 Revision A51.B69.R54
 Licensed from GEOSOLVE
 Data filename/Run ID: Hampstead_Wall_6_450mm_rev_02_ULS1
 Hampstead - 24-26 Redington Gardens
 Wall 6, Secant-ULS1, 450 dia @ 650 - run 02

Sheet No.
 Job No. 21495
 Made by : DBS
 Date:30-11-2018
 Checked :

Units: kN,m

Stage No. 13 Fill to elevation 43.65 on RIGHT side with soil type 1

BENDING MOMENT and DISPLACEMENT ANALYSIS of Fully Embedded Wall

Analysis options

Length of wall perpendicular to section = 50.00m
 Subgrade reaction model - Boussinesq Influence coefficients
 Soil deformations are elastic until the active or passive limit is reached
 Open Tension Crack analysis - No

Rigid boundaries: Left side 50.00 from wall
 Right side 50.00 from wall

Limit State: ULS DA1 Combination 1

Calculated Bending Moments and Strut Forces are to be multiplied by a factor of 1.35 to obtain values for structural design. See summary for factored values.

*** Wall displacements reset to zero at stage 4

Node no.	Y coord	Nett pressure kN/m2	Wall disp. m	Wall rotation rad.	Shear force kN/m	Bending moment kN.m/m	Strut forces kN/m	EI of wall kN.m2/m
1	49.75	0.00	0.003	-2.97E-03	0.0	0.0		60696
2	49.50	17.00	0.004	-2.97E-03	2.1	0.2		60696
3	49.40	25.09	0.004	-2.97E-03	4.2	0.5		60696
4	48.90	29.42	0.006	-3.00E-03	17.9	5.2		60696
5	48.40	19.46	0.007	-3.10E-03	30.1	18.2	127.3	60696
		19.46	0.007	-3.10E-03	-97.2	18.2		
6	48.10	24.32	0.008	-3.12E-03	-90.7	-10.0		60696
7	47.50	32.90	0.010	-2.78E-03	-73.5	-58.6		60696
		32.32	0.010	-2.78E-03	-73.5	-58.6		
8	47.15	36.93	0.011	-2.38E-03	-61.4	-82.3		60696
9	46.80	41.37	0.012	-1.85E-03	-47.7	-101.0		60696
10	46.20	48.77	0.012	-7.59E-04	-20.6	-121.1		60696
11	45.60	56.09	0.012	4.56E-04	10.8	-125.1		60696
12	45.00	63.42	0.012	1.61E-03	46.7	-108.7		60696
		24.53	0.012	1.61E-03	46.7	-108.7		
13	44.42	27.82	0.011	2.50E-03	61.7	-78.2		60696
14	43.85	31.23	0.009	3.05E-03	78.7	-38.3		60696
15	43.65	32.43	0.008	3.15E-03	85.1	-21.9		60696
16	43.17	32.44	0.007	3.15E-03	100.7	22.6		60696
		-111.81	0.007	3.15E-03	100.7	22.6		
17	43.00	-111.97	0.006	3.07E-03	81.6	38.5		60696
18	42.50	-99.94	0.005	2.64E-03	28.7	65.0		60696
19	42.00	-63.91	0.004	2.08E-03	-12.3	72.1		60696
20	41.40	-19.52	0.003	1.47E-03	-37.3	53.1		60696
21	40.80	13.45	0.002	1.07E-03	-39.2	27.2		60696
22	40.28	37.43	0.001	9.20E-04	-25.8	8.4		60696
23	39.75	60.88	0.001	8.84E-04	0.0	-0.0		---

At elev. 48.40 Strut force = 127.3 kN/strut = 127.3 kN/m run

Node no.	Y coord	LEFT side					Total earth pressure kN/m2	Coeff. of subgrade reaction kN/m3
		Water press. kN/m2	Vertical limit kN/m2	Active limit kN/m2	Passive limit kN/m2	Earth pressure kN/m2		
1	49.75	0.00	0.00	0.00	0.00	0.00	0.00	6810
2	49.50	0.00	4.95	1.67	17.03	17.00	17.00	6810
3	49.40	0.00	7.30	2.46	25.12	25.09	25.09	6810
4	48.90	4.90	17.13	5.77	58.96	24.51	29.42	6810
5	48.40	9.81	28.68	9.65	98.72	9.65	19.46a	6810

(continued)

Stage No.13 Fill to elevation 43.65 on RIGHT side with soil type 1

Node no.	Y coord	LEFT side					Total earth pressure	Coeff. of subgrade reaction
		Water press.	Vertic -al	Effective Active limit	Effective Passive limit	Earth pressure		
		kN/m2	kN/m2	kN/m2	kN/m2	kN/m2	kN/m2	kN/m3
6	48.10	12.75	34.36	11.57	118.26	11.57	24.32a	2296
7	47.50	18.64	42.32	14.25	145.69	14.26	32.90	2296
		18.64	42.32	13.65	154.35	13.68	32.32	6605
8	47.15	22.07	45.92	14.81	167.45	14.86	36.93	6605
9	46.80	25.51	48.94	15.79	178.47	15.86	41.37	6605
10	46.20	31.39	53.43	17.23	194.84	17.38	48.77	6605
11	45.60	37.28	57.55	18.56	209.87	18.81	56.09	6605
12	45.00	43.16	61.58	19.87	224.59	20.26	63.42	6605
		Total>	104.75	23.75m	224.26	24.53	24.53	13138
13	44.42	Total>	114.87	26.63m	241.25	27.82	27.82	13893
14	43.85	Total>	125.07	29.50m	258.32	31.23	31.23	14648
15	43.65	Total>	128.64	30.50m	264.28	32.43	32.43	14911
16	43.17	Total>	137.26	32.90m	278.64	35.35	35.35	15542
17	43.00	Total>	140.33	33.75m	283.74	40.43	40.43	15765
18	42.50	Total>	149.41	36.25m	298.80	67.93	67.93	16422
19	42.00	Total>	158.57	38.75m	313.94	93.17	93.17	17079
20	41.40	Total>	169.66	41.75m	332.20	119.31	119.31	17867
21	40.80	Total>	180.84	44.75m	350.55	141.73	141.73	18655
22	40.28	Total>	190.70	47.37m	366.68	159.80	159.80	19345
23	39.75	Total>	200.61	50.00m	382.87	177.73	177.73	20035

Node no.	Y coord	RIGHT side					Total earth pressure	Coeff. of subgrade reaction
		Water press.	Vertic -al	Effective Active limit	Effective Passive limit	Earth pressure		
		kN/m2	kN/m2	kN/m2	kN/m2	kN/m2	kN/m2	kN/m3
1	49.75	0.00	0.00	0.00	0.00	0.00	0.00	0.0
2	49.50	0.00	0.00	0.00	0.00	0.00	0.00	0.0
3	49.40	0.00	0.00	0.00	0.00	0.00	0.00	0.0
4	48.90	0.00	0.00	0.00	0.00	0.00	0.00	0.0
5	48.40	0.00	0.00	0.00	0.00	0.00	0.00	0.0
6	48.10	0.00	0.00	0.00	0.00	0.00	0.00	0.0
7	47.50	0.00	0.00	0.00	0.00	0.00	0.00	0.0
8	47.15	0.00	0.00	0.00	0.00	0.00	0.00	0.0
9	46.80	0.00	0.00	0.00	0.00	0.00	0.00	0.0
10	46.20	0.00	0.00	0.00	0.00	0.00	0.00	0.0
11	45.60	0.00	0.00	0.00	0.00	0.00	0.00	0.0
12	45.00	0.00	0.00	0.00	0.00	0.00	0.00	0.0
13	44.42	0.00	0.00	0.00	0.00	0.00	0.00	0.0
14	43.85	0.00	0.00	0.00	0.00	0.00	0.00	0.0
15	43.65	0.00	0.00	0.00	0.00	0.00	0.00	0.0
		0.00	0.00	0.00	0.00	0.00	0.00	2362
16	43.17	0.00	8.64	2.91	29.74	2.91	2.91a	2362
		Total>	8.64	2.40m	150.01	147.16	147.16	15941
17	43.00	Total>	12.04	3.25m	155.44	152.40	152.40	16170
18	42.50	Total>	22.04	5.75m	171.42	167.87	167.87	16844
19	42.00	Total>	32.04	8.25m	187.39	157.08	157.08	17518
20	41.40	Total>	44.04	11.25m	206.57	138.83	138.83	18326
21	40.80	Total>	56.05	14.25m	225.74	128.28	128.28	19135
22	40.28	Total>	66.55	16.88m	242.52	122.37	122.37	19842
23	39.75	Total>	77.06	19.50m	259.31	116.86	116.86	20550

Note: 2.91a Soil pressure at active limit
123.45p Soil pressure at passive limit

Units: kN,m

Stage No.13 Fill to elev. 43.65 on RIGHT side

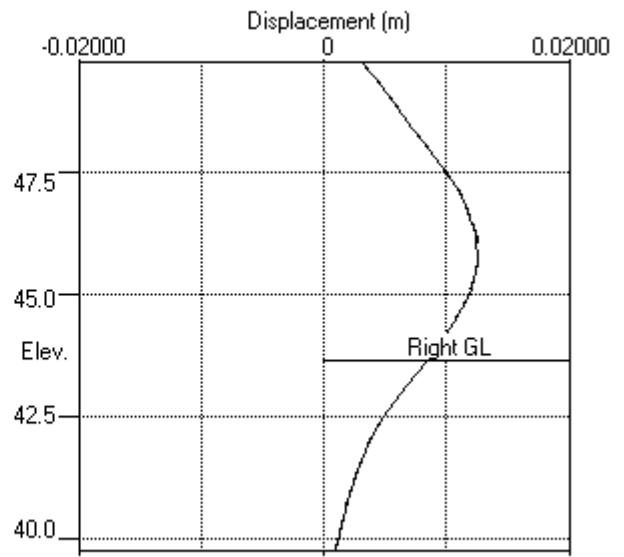
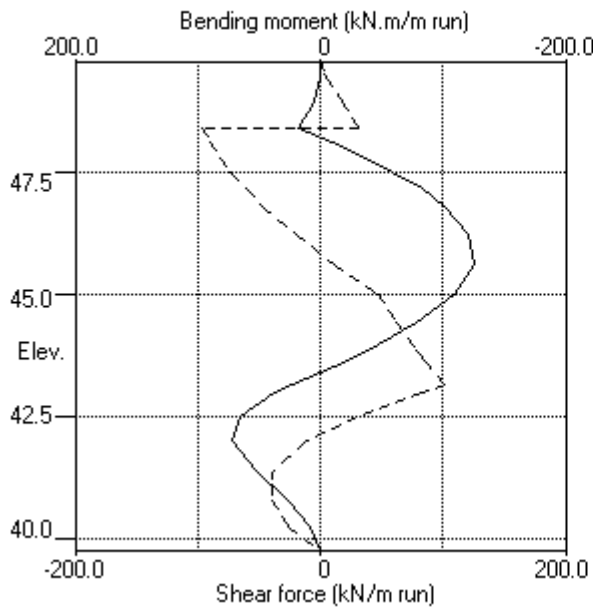

Stage No.13 Fill to elev. 43.65 on RIGHT side

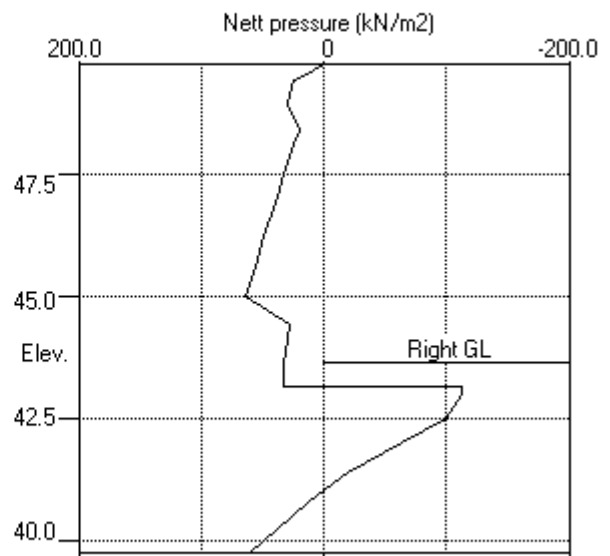
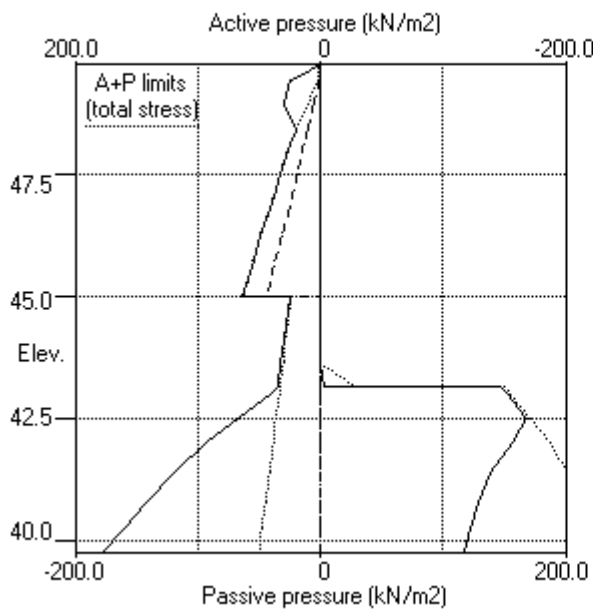

PILEDESIGNS LTD
 Program: WALLAP Version 6.06 Revision A51.B69.R54
 Licensed from GEOSOLVE
 Data filename/Run ID: Hampstead_Wall_6_450mm_rev_02_ULS1
 Hampstead - 24-26 Redington Gardens
 Wall 6, Secant-ULS1, 450 dia @ 650 - run 02

Sheet No.
 Job No. 21495
 Made by : DBS
 Date:30-11-2018
 Checked :

Units: kN,m

Stage No. 15 Change EI of wall to 43355 kN.m2/m run
 Yield moment not defined
 Allow wall to relax with new modulus value

BENDING MOMENT and DISPLACEMENT ANALYSIS of Fully Embedded Wall

Analysis options

Length of wall perpendicular to section = 50.00m
 Subgrade reaction model - Boussinesq Influence coefficients
 Soil deformations are elastic until the active or passive limit is reached
 Open Tension Crack analysis - No

Rigid boundaries: Left side 50.00 from wall
 Right side 50.00 from wall

Limit State: ULS DA1 Combination 1

Calculated Bending Moments and Strut Forces are to be multiplied by a factor of 1.35 to obtain values for structural design. See summary for factored values.

*** Wall displacements reset to zero at stage 4

Node no.	Y coord	Nett pressure kN/m2	Wall disp. m	Wall rotation rad.	Shear force kN/m	Bending moment kN.m/m	Strut forces kN/m	EI of wall kN.m2/m
1	49.75	0.00	0.002	-3.54E-03	0.0	0.0		43355
2	49.50	17.03	0.003	-3.54E-03	2.1	0.2		43355
3	49.40	25.12	0.004	-3.55E-03	4.2	0.5		43355
4	48.90	31.58	0.005	-3.58E-03	18.4	5.3		43355
5	48.40	19.50	0.007	-3.72E-03	31.2	18.7	122.9	43355
		19.50	0.007	-3.72E-03	-91.7	18.7		
6	48.10	24.32	0.008	-3.76E-03	-85.1	-8.3		43355
7	47.50	32.89	0.010	-3.34E-03	-68.0	-54.2		43355
		32.29	0.010	-3.34E-03	-68.0	-54.2		
8	47.15	36.88	0.012	-2.83E-03	-55.9	-76.4		43355
9	46.80	41.29	0.012	-2.16E-03	-42.2	-93.6		43355
10	46.20	48.63	0.013	-7.81E-04	-15.2	-111.2		43355
11	45.60	55.84	0.013	7.23E-04	16.1	-112.8		43355
12	45.00	63.03	0.013	2.10E-03	51.8	-94.0		43355
		23.75	0.013	2.10E-03	51.8	-94.0		
13	44.42	26.63	0.011	3.07E-03	66.3	-61.3		43355
14	43.85	30.65	0.009	3.54E-03	82.7	-19.5	28.1	43355
		30.65	0.009	3.54E-03	54.6	-19.5		
15	43.65	33.62	0.008	3.58E-03	61.0	-6.9		43355
16	43.17	37.30	0.007	3.43E-03	78.1	28.7		43355
		-102.09	0.007	3.43E-03	78.1	28.7		
17	43.00	-100.29	0.006	3.29E-03	60.9	41.8		43355
18	42.50	-84.76	0.005	2.70E-03	14.6	61.4		43355
19	42.00	-48.68	0.003	1.99E-03	-18.8	64.4		43355
20	41.40	-8.01	0.002	1.27E-03	-35.8	44.6		43355
21	40.80	18.86	0.002	8.49E-04	-32.5	21.0		43355
22	40.28	35.22	0.001	7.04E-04	-18.3	5.6		43355
23	39.75	34.59	0.001	6.75E-04	0.0	-0.0		---
At elev. 48.40 Strut force =			122.9 kN/strut =		122.9 kN/m run			
At elev. 43.85 Strut force =			28.1 kN/strut =		28.1 kN/m run			

(continued)

Stage No.15 Change EI of wall to 43355 kN.m2/m run
 Yield moment not defined
 Allow wall to relax with new modulus value

Node no.	Y coord	LEFT side					Total earth pressure	Coeff. of subgrade reaction
		Water press.	Vertic -al	Effective Active limit	Effective Passive limit	Earth pressure		
		kN/m2	kN/m2	kN/m2	kN/m2	kN/m2	kN/m2	kN/m3
1	49.75	0.00	0.00	0.00	0.00	0.00	0.00	7103
2	49.50	0.00	4.95	1.67	17.03	17.03	17.03p	7103
3	49.40	0.00	7.30	2.46	25.12	25.12	25.12p	7103
4	48.90	4.90	17.13	5.77	58.96	26.67	31.58	7103
5	48.40	9.81	28.68	9.65	98.72	9.69	19.50	7103
6	48.10	12.75	34.36	11.57	118.26	11.57	24.32a	2762
7	47.50	18.64	42.32	14.25	145.69	14.25	32.89a	2762
		18.64	42.32	13.65	154.35	13.65	32.29a	7962
8	47.15	22.07	45.92	14.81	167.45	14.81	36.88a	7962
9	46.80	25.51	48.94	15.79	178.47	15.79	41.29a	7962
10	46.20	31.39	53.43	17.23	194.84	17.23	48.63a	7962
11	45.60	37.28	57.55	18.56	209.87	18.56	55.84a	7962
12	45.00	43.16	61.58	19.87	224.59	19.87	63.03a	7962
		Total>	104.75	23.75m	224.26	23.75	23.75a	15526
13	44.42	Total>	114.87	26.63m	241.25	26.63	26.63a	16419
14	43.85	Total>	125.07	29.50m	258.32	30.65	30.65	17312
15	43.65	Total>	128.64	30.50m	264.28	33.62	33.62	20432
16	43.17	Total>	137.26	32.90m	278.64	40.21	40.21	21296
17	43.00	Total>	140.33	33.75m	283.74	46.27	46.27	21602
18	42.50	Total>	149.41	36.25m	298.80	75.51	75.51	22502
19	42.00	Total>	158.57	38.75m	313.94	100.79	100.79	23403
20	41.40	Total>	169.66	41.75m	332.20	125.06	125.06	24483
21	40.80	Total>	180.84	44.75m	350.55	144.44	144.44	25563
22	40.28	Total>	190.70	47.37m	366.68	158.69	158.69	104380
23	39.75	Total>	200.61	50.00m	382.87	164.59	164.59	108101

Node no.	Y coord	RIGHT side					Total earth pressure	Coeff. of subgrade reaction
		Water press.	Vertic -al	Effective Active limit	Effective Passive limit	Earth pressure		
		kN/m2	kN/m2	kN/m2	kN/m2	kN/m2	kN/m2	kN/m3
1	49.75	0.00	0.00	0.00	0.00	0.00	0.00	0.0
2	49.50	0.00	0.00	0.00	0.00	0.00	0.00	0.0
3	49.40	0.00	0.00	0.00	0.00	0.00	0.00	0.0
4	48.90	0.00	0.00	0.00	0.00	0.00	0.00	0.0
5	48.40	0.00	0.00	0.00	0.00	0.00	0.00	0.0
6	48.10	0.00	0.00	0.00	0.00	0.00	0.00	0.0
7	47.50	0.00	0.00	0.00	0.00	0.00	0.00	0.0
8	47.15	0.00	0.00	0.00	0.00	0.00	0.00	0.0
9	46.80	0.00	0.00	0.00	0.00	0.00	0.00	0.0
10	46.20	0.00	0.00	0.00	0.00	0.00	0.00	0.0
11	45.60	0.00	0.00	0.00	0.00	0.00	0.00	0.0
12	45.00	0.00	0.00	0.00	0.00	0.00	0.00	0.0
13	44.42	0.00	0.00	0.00	0.00	0.00	0.00	0.0
14	43.85	0.00	0.00	0.00	0.00	0.00	0.00	0.0
15	43.65	0.00	0.00	0.00	0.00	0.00	0.00	0.0
		0.00	0.00	0.00	0.00	0.00	0.00	3241
16	43.17	0.00	8.64	2.91	29.74	2.91	2.91a	3241
		Total>	8.64	2.40m	150.01	142.30	142.30	21296
17	43.00	Total>	12.04	3.25m	155.44	146.56	146.56	21602
18	42.50	Total>	22.04	5.75m	171.42	160.28	160.28	22502
19	42.00	Total>	32.04	8.25m	187.39	149.46	149.46	23403

(continued)

Stage No.15 Change EI of wall to 43355 kN.m2/m run
 Yield moment not defined
 Allow wall to relax with new modulus value

Node no.	Y coord	----- RIGHT side -----						
		Water press. kN/m2	Vertic -al kN/m2	Effective Active limit kN/m2	Effective Passive limit kN/m2	Earth pressure kN/m2	Total earth pressure kN/m2	Coeff. of subgrade reaction kN/m3
20	41.40	Total>	44.04	11.25m	206.57	133.08	133.08	24483
21	40.80	Total>	56.05	14.25m	225.74	125.58	125.58	25563
22	40.28	Total>	66.55	16.88m	242.52	123.47	123.47	104380
23	39.75	Total>	77.06	19.50m	259.31	130.00	130.00	108101

Note: 2.91a Soil pressure at active limit
 25.12p Soil pressure at passive limit

Units: kN,m

Stage No.15 Change EI of wall to 43355kN.m²/m run

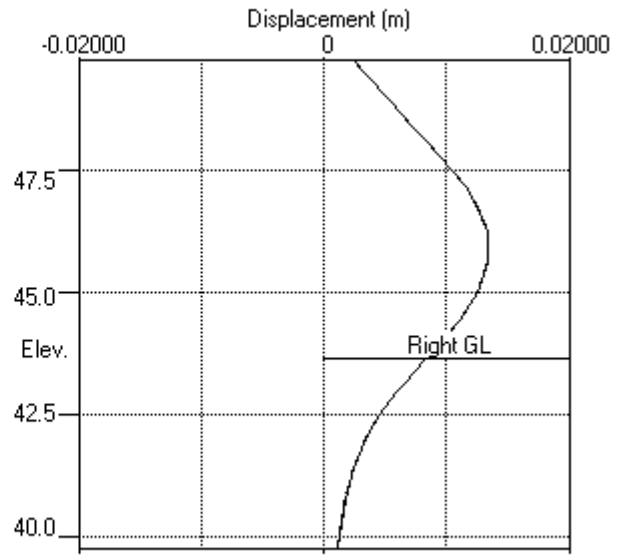
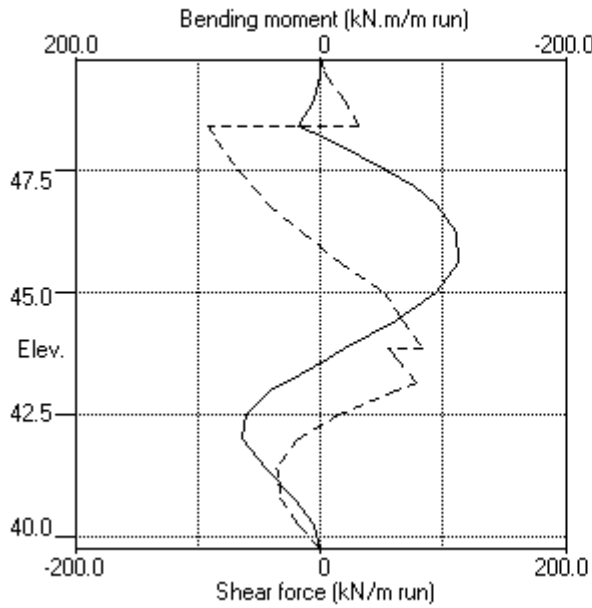

Stage No.15 Change EI of wall to 43355kN.m²/m run

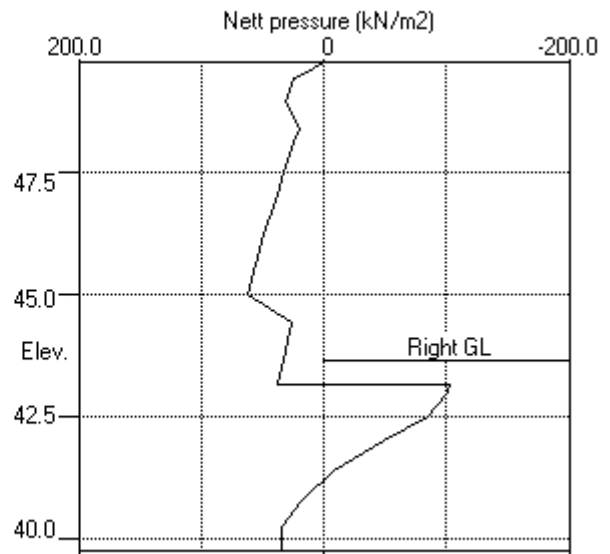
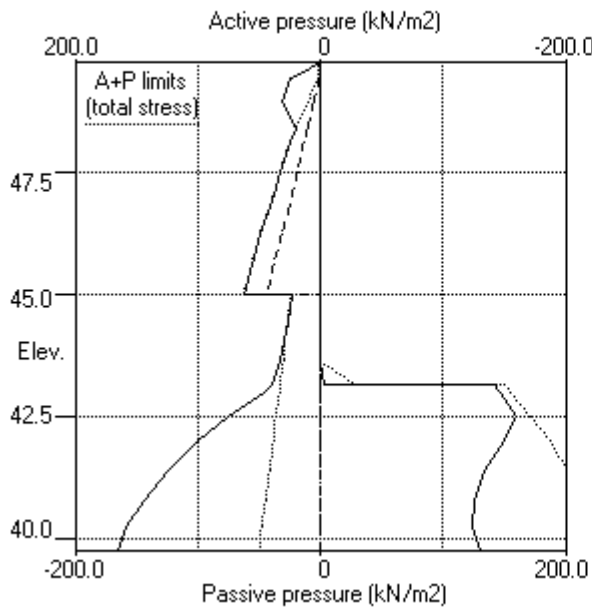

PILEDESIGNS LTD
 Program: WALLAP Version 6.06 Revision A51.B69.R54
 Licensed from GEOSOLVE
 Data filename/Run ID: Hampstead_Wall_6_450mm_rev_02_ULS1
 Hampstead - 24-26 Redington Gardens
 Wall 6, Secant-ULS1, 450 dia @ 650 - run 02

Sheet No.
 Job No. 21495
 Made by : DBS
 Date: 30-11-2018
 Checked :

Units: kN,m

Stage No. 16 Change properties of soil type 3 to soil type 4
 Ko pressures will not be reset

BENDING MOMENT and DISPLACEMENT ANALYSIS of Fully Embedded Wall

Analysis options

Length of wall perpendicular to section = 50.00m
 Subgrade reaction model - Boussinesq Influence coefficients
 Soil deformations are elastic until the active or passive limit is reached
 Open Tension Crack analysis - No

Rigid boundaries: Left side 50.00 from wall
 Right side 50.00 from wall

Limit State: ULS DA1 Combination 1

Calculated Bending Moments and Strut Forces are to be multiplied by a factor of 1.35 to obtain values for structural design. See summary for factored values.

*** Wall displacements reset to zero at stage 4

Node no.	Y coord	Nett pressure kN/m ²	Wall disp. m	Wall rotation rad.	Shear force kN/m	Bending moment kN.m/m	Strut forces kN/m	EI of wall kN.m ² /m
1	49.75	0.00	0.003	-3.23E-03	0.0	0.0		43355
2	49.50	14.50	0.004	-3.23E-03	1.8	0.2		43355
3	49.40	22.82	0.004	-3.23E-03	3.7	0.5		43355
4	48.90	30.44	0.006	-3.26E-03	17.0	4.6		43355
5	48.40	19.52	0.007	-3.38E-03	29.5	17.2	117.7	43355
		19.52	0.007	-3.38E-03	-88.2	17.2		
6	48.10	24.62	0.008	-3.42E-03	-81.6	-8.7		43355
7	47.50	33.75	0.010	-3.01E-03	-64.0	-52.4		43355
		34.78	0.010	-3.01E-03	-64.0	-52.4		
8	47.15	40.28	0.011	-2.52E-03	-50.9	-73.1		43355
9	46.80	45.51	0.012	-1.88E-03	-35.9	-88.3		43355
10	46.20	53.95	0.013	-6.10E-04	-6.1	-101.4		43355
11	45.60	61.59	0.013	7.14E-04	28.6	-96.6		43355
12	45.00	68.10	0.012	1.80E-03	67.5	-69.2		43355
		64.80	0.012	1.80E-03	67.5	-69.2		
13	44.42	72.01	0.011	2.34E-03	106.8	-20.5		43355
14	43.85	79.25	0.009	2.07E-03	150.3	52.3	248.4	43355
		79.25	0.009	2.07E-03	-98.1	52.3		
15	43.65	81.78	0.009	1.84E-03	-82.0	35.4		43355
16	43.17	81.11	0.008	1.57E-03	-42.9	7.9		43355
		59.76	0.008	1.57E-03	-42.9	7.9		
17	43.00	50.86	0.008	1.55E-03	-33.5	2.6		43355
18	42.50	35.75	0.007	1.58E-03	-11.9	-7.4		43355
19	42.00	20.67	0.006	1.67E-03	2.3	-4.6		43355
20	41.40	2.60	0.005	1.75E-03	9.2	-2.8		43355
21	40.80	-15.01	0.004	1.79E-03	5.5	1.4		43355
22	40.28	-5.85	0.003	1.79E-03	0.0	1.6		43355
23	39.75	5.72	0.002	1.79E-03	0.0	-0.0		---
At elev. 48.40 Strut force =			117.7 kN/strut =		117.7 kN/m run			
At elev. 43.85 Strut force =			248.4 kN/strut =		248.4 kN/m run			

(continued)

Stage No.16 Change properties of soil type 3 to soil type 4
Ko pressures will not be reset

Node no.	Y coord	LEFT side					Total earth pressure	Coeff. of subgrade reaction
		Water press.	Vertical	Effective Active limit	Effective Passive limit	Earth pressure		
		kN/m2	kN/m2	kN/m2	kN/m2	kN/m2	kN/m2	kN/m3
1	49.75	0.00	0.00	0.00	0.00	0.00	0.00	7245
2	49.50	0.00	4.95	1.67	17.03	14.50	14.50	7245
3	49.40	0.00	7.30	2.46	25.12	22.82	22.82	7245
4	48.90	4.90	17.13	5.77	58.96	25.53	30.44	7245
5	48.40	9.81	28.68	9.65	98.72	9.71	19.52	2779
6	48.10	12.75	34.36	11.57	118.26	11.87	24.62	2779
7	47.50	18.64	42.32	14.25	145.69	15.11	33.75	2779
		18.64	42.32	13.65	154.35	16.14	34.78	8011
8	47.15	22.07	45.92	14.81	167.45	18.20	40.28	8011
9	46.80	25.51	48.94	15.79	178.47	20.00	45.51	8011
10	46.20	31.39	53.43	17.23	194.84	22.55	53.95	8011
11	45.60	37.28	57.55	18.56	209.87	24.31	61.59	8011
12	45.00	43.16	61.58	19.87	224.59	24.94	68.10	8011
		43.16	61.58	21.63	200.32	21.63	64.80a	8224
13	44.42	48.80	66.06	23.21	214.88	23.21	72.01a	8697
14	43.85	54.45	70.62	24.81	229.71	24.81	79.25a	8587
15	43.65	56.41	72.23	25.37	234.95	25.37	81.78a	8741
16	43.17	61.12	76.14	26.75	247.67	26.75	87.86a	9111
17	43.00	62.78	77.55	27.24	252.24	27.24	90.02a	9242
18	42.50	67.69	81.72	28.71	265.83	28.71	96.40a	9627
19	42.00	72.59	85.98	30.20	279.67	30.20	102.80a	10012
20	41.40	78.48	91.18	32.03	296.59	32.03	110.51a	10474
21	40.80	84.37	96.48	33.89	313.81	34.32	118.68	10936
22	40.28	89.52	101.18	35.54	329.12	48.64	138.16	11341
23	39.75	94.67	105.94	37.21	344.61	55.49	150.15	11745

Node no.	Y coord	RIGHT side					Total earth pressure	Coeff. of subgrade reaction
		Water press.	Vertical	Effective Active limit	Effective Passive limit	Earth pressure		
		kN/m2	kN/m2	kN/m2	kN/m2	kN/m2	kN/m2	kN/m3
1	49.75	0.00	0.00	0.00	0.00	0.00	0.00	0.0
2	49.50	0.00	0.00	0.00	0.00	0.00	0.00	0.0
3	49.40	0.00	0.00	0.00	0.00	0.00	0.00	0.0
4	48.90	0.00	0.00	0.00	0.00	0.00	0.00	0.0
5	48.40	0.00	0.00	0.00	0.00	0.00	0.00	0.0
6	48.10	0.00	0.00	0.00	0.00	0.00	0.00	0.0
7	47.50	0.00	0.00	0.00	0.00	0.00	0.00	0.0
8	47.15	0.00	0.00	0.00	0.00	0.00	0.00	0.0
9	46.80	0.00	0.00	0.00	0.00	0.00	0.00	0.0
10	46.20	0.00	0.00	0.00	0.00	0.00	0.00	0.0
11	45.60	0.00	0.00	0.00	0.00	0.00	0.00	0.0
12	45.00	0.00	0.00	0.00	0.00	0.00	0.00	0.0
13	44.42	0.00	0.00	0.00	0.00	0.00	0.00	0.0
14	43.85	0.00	0.00	0.00	0.00	0.00	0.00	0.0
15	43.65	0.00	0.00	0.00	0.00	0.00	0.00	0.0
		0.00	0.00	0.00	0.00	0.00	0.00	2604
16	43.17	0.00	8.64	2.91	29.74	6.75	6.75	2604
		0.00	8.64	3.03	28.10	28.10	28.10p	9111
17	43.00	0.00	12.04	4.23	39.16	39.16	39.16p	9242
18	42.50	4.90	17.14	6.02	55.74	55.74	60.64p	9627
19	42.00	9.81	22.23	7.81	72.31	72.31	82.12p	10012
20	41.40	15.70	28.35	9.96	92.21	92.21	107.91p	10474

(continued)

Stage No.16 Change properties of soil type 3 to soil type 4
 Ko pressures will not be reset

Node no.	Y coord	----- RIGHT side -----					Total earth pressure kN/m2	Coeff. of subgrade reaction kN/m3
		Water press. kN/m2	Vertic -al kN/m2	Effective Active limit kN/m2	Effective Passive limit kN/m2	Earth pressure kN/m2		
21	40.80	21.58	34.47	12.11	112.11	112.11	133.69p	10936
22	40.28	26.73	39.82	13.99	129.53	117.28	144.01	11341
23	39.75	31.88	45.18	15.87	146.96	112.55	144.44	11745

Note: 110.51a Soil pressure at active limit
 133.69p Soil pressure at passive limit

Units: kN,m

Stage No.16 Change soil type 3 to soil type 4

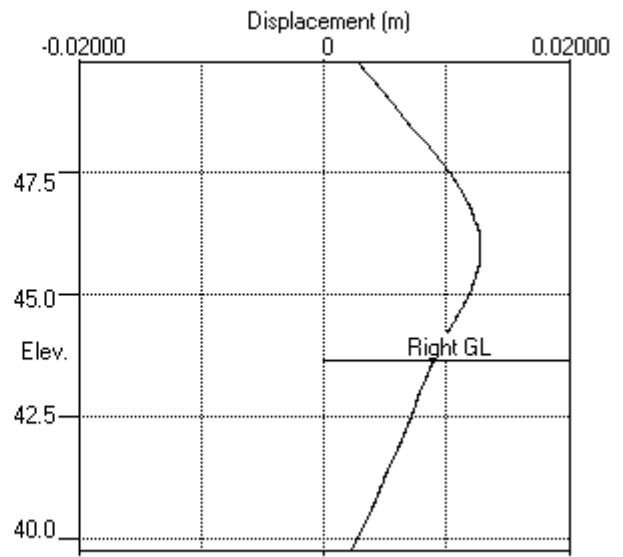
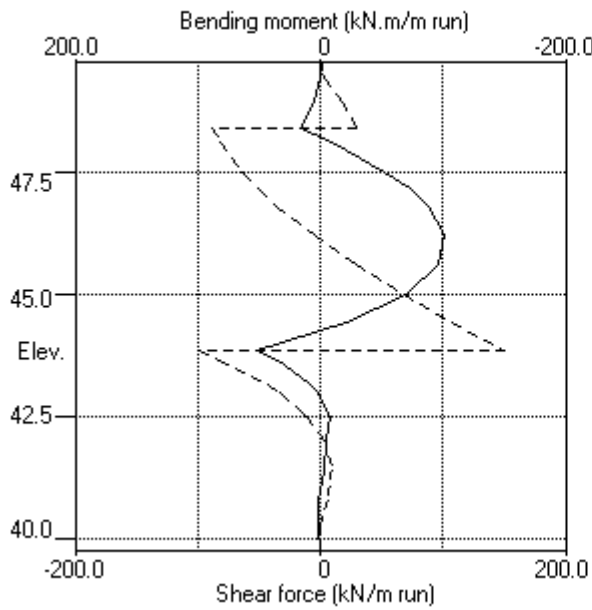

Stage No.16 Change soil type 3 to soil type 4

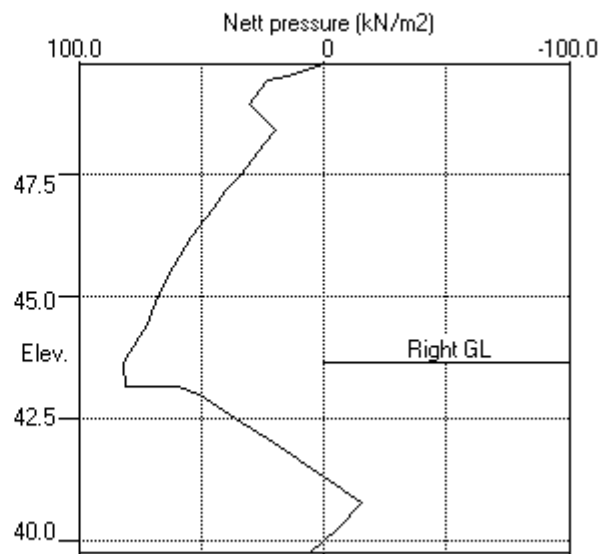
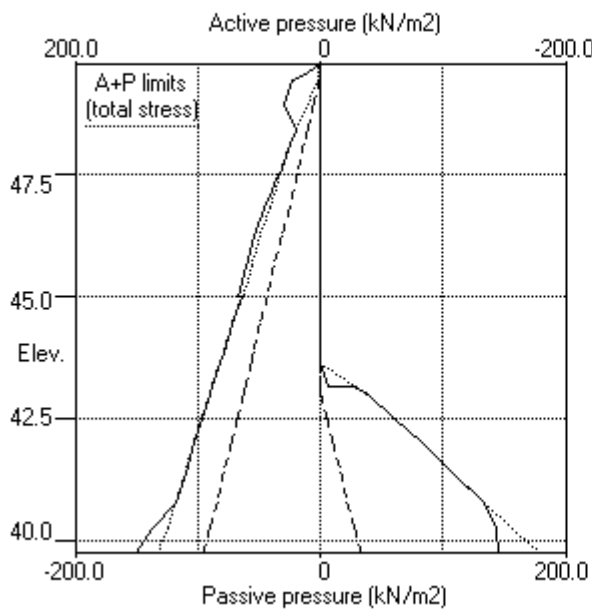

PILEDESIGNS LTD
 Program: WALLAP Version 6.06 Revision A51.B69.R54
 Licensed from GEOSOLVE
 Data filename/Run ID: Hampstead_Wall_6_450mm_rev_02_ULS1
 Hampstead - 24-26 Redington Gardens
 Wall 6, Secant-ULS1, 450 dia @ 650 - run 02

Sheet No.
 Job No. 21495
 Made by : DBS
 Date: 30-11-2018
 Checked :

Units: kN,m

Summary of results

BENDING MOMENT and DISPLACEMENT ANALYSIS of Fully Embedded Wall

Analysis options

Length of wall perpendicular to section = 50.00m
 Subgrade reaction model - Boussinesq Influence coefficients
 Soil deformations are elastic until the active or passive limit is reached
 Open Tension Crack analysis - No

Rigid boundaries: Left side 50.00 from wall
 Right side 50.00 from wall

Limit State: ULS DA1 Combination 1

Calculated Bending Moments and Strut Forces have been multiplied by a factor of 1.35 to obtain values for structural design.

Bending moment, shear force and displacement envelopes

Node no.	Y coord	Displacement		Bending moment				Shear force			
		max. m	min. m	Calculated		Factored		Calculated		Factored	
				max. kN.m/m	min. kN.m/m	max. kN.m/m	min. kN.m/m	max. kN/m	min. kN/m	max. kN/m	min. kN/m
1	49.75	0.010	0.000	0	0	0	0	0	0	0	0
2	49.50	0.010	0.000	0	-0	0	-0	2	-1	3	-1
3	49.40	0.009	0.000	1	-0	1	-0	4	-1	6	-2
4	48.90	0.008	0.000	5	-1	7	-2	18	-4	25	-5
5	48.40	0.007	0.000	19	-3	25	-4	31	-97	42	-131
6	48.10	0.008	0.000	9	-10	12	-14	18	-91	24	-122
7	47.50	0.010	0.000	24	-59	32	-79	27	-73	36	-99
8	47.15	0.012	0.000	32	-82	44	-111	22	-61	30	-83
9	46.80	0.012	0.000	39	-101	53	-136	14	-48	19	-64
10	46.20	0.013	0.000	43	-121	59	-163	3	-21	3	-28
11	45.60	0.013	0.000	39	-125	52	-169	29	-11	39	-14
12	45.00	0.013	0.000	30	-109	41	-147	68	-14	91	-19
13	44.42	0.011	0.000	22	-78	29	-106	107	-14	144	-19
14	43.85	0.009	0.000	52	-38	71	-52	150	-98	203	-132
15	43.65	0.009	0.000	35	-22	48	-30	85	-82	115	-111
16	43.17	0.008	0.000	29	0	39	0	101	-43	136	-58
17	43.00	0.008	0.000	42	0	56	0	82	-34	110	-45
18	42.50	0.007	0.000	65	-7	88	-10	29	-12	39	-16
19	42.00	0.006	0.000	72	-5	97	-6	2	-19	3	-25
20	41.40	0.005	0.000	53	-3	72	-4	9	-37	12	-50
21	40.80	0.004	0.000	27	-0	37	-0	6	-39	7	-53
22	40.28	0.003	0.000	8	-0	11	-0	0	-26	0	-35
23	39.75	0.002	0.000	0	-0	0	-0	0	-0	0	-0

Summary of results (continued)

Calculated Bending Moments and Strut Forces have been multiplied by a factor of 1.35 to obtain values for structural design.

Maximum and minimum bending moment and shear force at each stage

Stage no.	Bending moment				Shear force			
	Calculated		Factored		Calculated		Factored	
min.	max. elev.	min. elev.	max. elev.	max.	min.	max.	min.	max.
	kN.m/m		kN.m/m		kN/m		kN/m	
1	0	43.85	-0	47.15	1	-0	0	45.00
-0								
2	No calculation at this stage							
3	No calculation at this stage							
4	No calculation at this stage							
5	No calculation at this stage							
6	No calculation at this stage							
7	No calculation at this stage							
8	6	43.85	-4	48.10	9	-5	6	45.00
-5								
9	43	46.20	-0	40.28	59	-0	27	47.50
-19								
10	No calculation at this stage							
11	35	46.20	-0	39.75	48	-0	22	47.50
-13								
12	71	42.00	-124	45.60	95	-168	99	43.17
-131								
13	72	42.00	-125	45.60	97	-169	101	43.17
-131								
14	No calculation at this stage							
15	64	42.00	-113	45.60	87	-152	83	43.85
-124								
16	52	43.85	-101	46.20	71	-137	150	43.85
-132								
17	No calculation at this stage							
18	30	43.85	-107	46.20	40	-144	142	43.85
-122								

Maximum and minimum displacement at each stage

Stage no.	Displacement				Stage description
	maximum	elev.	minimum	elev.	
	m		m		
1	0.000	49.75	0.000	49.75	Apply surcharge no.1 at elev. 49.75
2	No calculation at this stage				Apply surcharge no.2 at elev. 49.50
3	No calculation at this stage				Apply surcharge no.3 at elev. 49.75
4	Wall displacements reset to zero				Change EI of wall to 60696kN.m2/m run
5	No calculation at this stage				Apply surcharge no.4 at elev. 49.75
6	No calculation at this stage				Apply surcharge no.5 at elev. 49.50
7	No calculation at this stage				Apply surcharge no.6 at elev. 49.75
8	0.002	49.75	0.000	49.75	Apply water pressure profile no.1
9	0.010	49.75	0.000	49.75	Excav. to elev. 48.10 on RIGHT side
10	No calculation at this stage				Install strut no.1 at elev. 48.40
11	0.010	49.75	0.000	49.75	Apply water pressure profile no.2
12	0.013	45.60	0.000	49.75	Excav. to elev. 43.17 on RIGHT side
13	0.012	45.60	0.000	49.75	Fill to elev. 43.65 on RIGHT side
14	No calculation at this stage				Install strut no.2 at elev. 43.85
15	0.013	45.60	0.000	49.75	Change EI of wall to 43355kN.m2/m run
16	0.013	46.20	0.000	49.75	Change soil type 3 to soil type 4
17	No calculation at this stage				Apply surcharge no.7 at elev. 43.65
18	0.013	46.20	0.000	49.75	Apply water pressure profile no.3

Summary of results (continued)

Calculated Bending Moments and Strut Forces have been multiplied by a factor of 1.35 to obtain values for structural design.

Strut forces at each stage (horizontal components)

Stage no.	----- Strut no. 1 ----- at elev. 48.40			----- Strut no. 2 ----- at elev. 43.85		
	--Calculated--		Factored	--Calculated--		Factored
	kN per m run	kN per strut	kN per strut	kN per m run	kN per strut	kN per strut
11	6	6	8	---	---	---
12	127	127	171	---	---	---
13	127	127	172	---	---	---
15	123	123	166	28	28	38
16	118	118	159	248	248	335
18	120	120	163	192	192	259

Units: kN,m

Bending moment, shear force, displacement envelopes

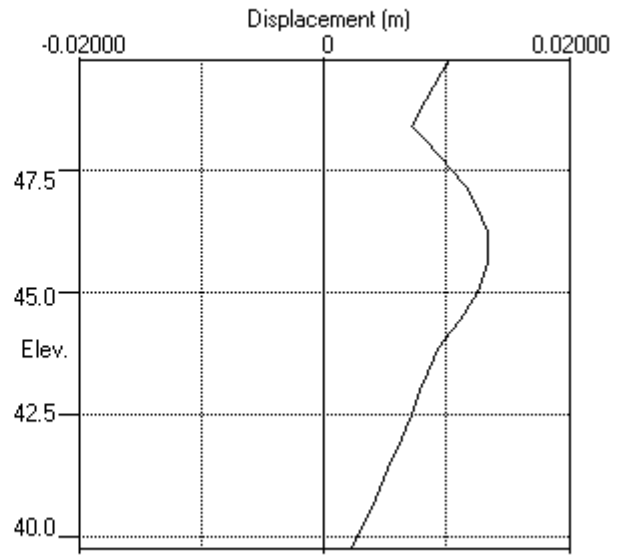
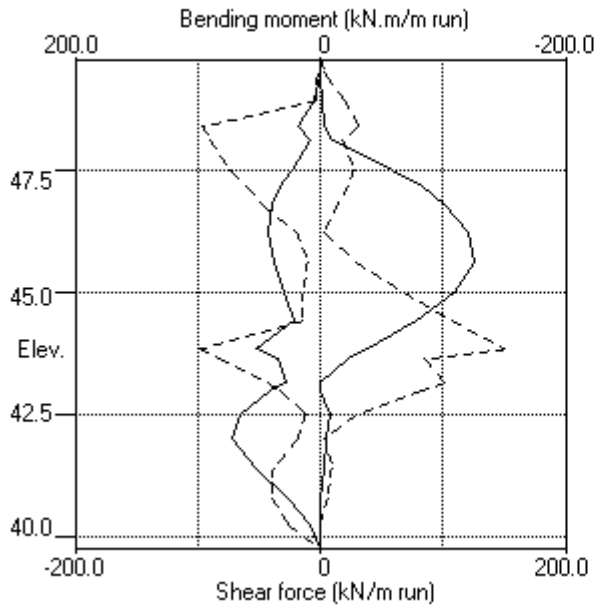



WALLAP

6-ULS2

PILEDESIGNS LTD
 Program: WALLAP Version 6.06 Revision A51.B69.R54
 Licensed from GEOSOLVE
 Data filename/Run ID: Hampstead_Wall_6_450mm_rev_02_ULS2
 Hampstead - 24-26 Redington Gardens
 Wall 6, Secant-ULS2, 450 dia @ 650 - run 02

Sheet No.
 Job No. 21495
 Made by : DBS
 Date:30-11-2018
 Checked :

Units: kN,m

INPUT DATA

SOIL PROFILE

Stratum no.	Elevation of top of stratum	Soil types	
		Left side	Right side
1	49.75	1 Made Ground dr	1 Made Ground dr
2	47.50	2 Claygate Clay dr	2 Claygate Clay dr
3	45.00	3 London Clay und	3 London Clay und

SOIL PROPERTIES (Unfactored SLS soil strengths)

No. Description (Datum elev.)	Bulk density kN/m3	Young's Modulus Eh,kN/m2 (dEh/dy)	At rest coeff. Ko (dKo/dy)	Consol state. NC/OC (Nu)	Active limit Ka (Kac)	Passive limit Kp (Kpc)	Cohesion kN/m2 (dc/dy)
1 Made Ground dr	18.00	10000	0.561	OC (0.250)	0.337 (0.000)	3.442 (0.000)	
2 Claygate Clay dr	19.00	30000	1.000	NC (0.200)	0.323 (1.330)	3.647 (5.195)	0.0d
3 London Cl.. (45.00)	20.00	40000 (4000)	1.000	OC (0.490)	1.000 (2.476)	1.000 (2.390)	50.00u (5.000)
4 London Cl.. (45.00)	20.00	30800 (3080)	1.000	OC (0.200)	0.351 (1.391)	3.253 (4.831)	0.0d

Additional soil parameters associated with Ka and Kp

No. Description	--- parameters for Ka ---			--- parameters for Kp ---		
	Soil friction angle	Wall adhesion coeff.	Back-fill angle	Soil friction angle	Wall adhesion coeff.	Back-fill angle
1 Made Ground dr	26.00	0.670	0.00	26.00	0.500	0.00
2 Claygate Clay dr	27.00	0.670	0.00	27.00	0.500	0.00
3 London Clay und	0.00	0.670	0.00	0.00	0.500	0.00
4 London Clay dr	25.00	0.670	0.00	25.00	0.500	0.00

GROUND WATER CONDITIONS

Density of water = 9.810 kN/m3

	Left side	Right side
Initial water table elevation	49.40	49.40

Automatic water pressure balancing at toe of wall : No

Water profile no.	Point no.	Left side			Right side			
		Elev. m	Piezo elev. m	Water press. kN/m2	Point no.	Elev. m	Piezo elev. m	Water press. kN/m2
1	1	49.40	49.40	0.0	1	47.50	47.50	0.0 MC+WC
	2	49.40	49.40	0.0	1	43.00	43.00	0.0 MC+WC
3	1	49.40	49.40	0.0	1	43.65	43.65	0.0 MC+WC
	2				2	43.65	49.40	56.4

WALL PROPERTIES

Type of structure = Fully Embedded Wall
 Elevation of toe of wall = 39.75
 Maximum finite element length = 0.60 m
 Youngs modulus of wall E = 1.9600E+07 kN/m2
 Moment of inertia of wall I = 3.0968E-03 m4/m run
 E.I = 60696 kN.m2/m run
 Yield Moment of wall = Not defined

STRUTS and ANCHORS

Strut/ anchor no.	Elev.	Strut spacing m	X-section area of strut sq.m	Youngs modulus kN/m2	Free length m	Inclin -ation (degs)	Pre- stress /strut kN	Tension allowed
1	48.40	1.00	0.300000	1.400E+07	5.00	0.00	0	No
2	43.85	1.00	0.300000	1.400E+07	5.00	0.00	0	No

SURCHARGE LOADS

Surch -arge no.	Elev.	Distance from wall	Length parallel to wall	Width perpend. to wall	Surcharge ----- kN/m2 ----- Near edge Far edge		Equiv. soil type	Partial factor/ Category
1	49.75	0.50(L)	10.00	0.60	6.50	=	N/A	1.00 P/U
2	49.50	1.10(L)	10.00	0.50	50.00	=	N/A	1.00 P/U
3	49.75	1.60(L)	10.00	5.00	6.50	=	N/A	1.00 P/U
4	49.75	0.50(L)	10.00	0.60	5.00	=	N/A	1.30 Var
5	49.50	1.10(L)	10.00	0.50	40.00	=	N/A	1.30 Var
6	49.75	1.60(L)	10.00	5.00	5.00	=	N/A	1.30 Var
7	43.65	-0.00(R)	10.00	10.00	57.00	=	N/A	1.00 P/F

Note: L = Left side, R = Right side

Limit State Categories P/U = Permanent Unfavourable

P/F = Permanent Favourable

Var = Variable (unfavourable)

CONSTRUCTION STAGES

Construction stage no.	Stage description -----
1	Apply surcharge no.1 at elevation 49.75
2	Apply surcharge no.2 at elevation 49.50 No analysis at this stage
3	Apply surcharge no.3 at elevation 49.75 No analysis at this stage
4	Change EI of wall to 60696 kN.m2/m run Yield moment not defined Reset wall displacements to zero at this stage
5	Apply surcharge no.4 at elevation 49.75 No analysis at this stage
6	Apply surcharge no.5 at elevation 49.50 No analysis at this stage
7	Apply surcharge no.6 at elevation 49.75 No analysis at this stage
8	Apply water pressure profile no.1 (Worst Cred.)
9	Excavate to elevation 48.10 on RIGHT side
10	Install strut or anchor no.1 at elevation 48.40
11	Apply water pressure profile no.2 (Worst Cred.)
12	Excavate to elevation 43.17 on RIGHT side
13	Fill to elevation 43.65 on RIGHT side with soil type 1
14	Install strut or anchor no.2 at elevation 43.85
15	Change EI of wall to 43355 kN.m2/m run Yield moment not defined Allow wall to relax with new modulus value
16	Change properties of soil type 3 to soil type 4 Ko pressures will not be reset
17	Apply surcharge no.7 at elevation 43.65 No analysis at this stage
18	Apply water pressure profile no.3 (Worst Cred.)

FACTORS OF SAFETY and ANALYSIS OPTIONS

Limit State options: ULS DA1 Combination 2
Water pressures : Worst Credible
Partial factor on C' = 1.250
Partial factor on Phi' = 1.250
Partial factor on Cu = 1.400
Partial factor on Soil Modulus = 1.000
Partial factor on Permanent Unfavourable loads = 1.000
Partial factor on Permanent Favourable loads = 1.000
Partial factor on Variable Unfavourable loads = 1.300

Stability analysis:
Method of analysis - Strength Factor method
Overall factor on soil strength for calculating wall depth = 1.00

Parameters for undrained strata:
Minimum equivalent fluid density = 5.00 kN/m3
Maximum depth of water filled tension crack = 0.00 m

Bending moment and displacement calculation:
Method - Subgrade reaction model using Influence Coefficients
Open Tension Crack analysis? - No
Non-linear Modulus Parameter (L) = 10.00 m

Boundary conditions:
Length of wall (normal to plane of analysis) = 50.00 m

Width of excavation on Left side of wall = 50.00 m
Width of excavation on Right side of wall = 50.00 m

Distance to rigid boundary on Left side = 50.00 m
Distance to rigid boundary on Right side = 50.00 m

OUTPUT OPTIONS

Stage no.	Stage description	Displacement	Active, Bending mom. Shear force	Graph. Passive output pressures
1	Apply surcharge no.1 at elev. 49.75	No	No	No
2	Apply surcharge no.2 at elev. 49.50	Yes	Yes	Yes
3	Apply surcharge no.3 at elev. 49.75	Yes	Yes	Yes
4	Change EI of wall to 60696kN.m2/m run	Yes	Yes	Yes
5	Apply surcharge no.4 at elev. 49.75	Yes	Yes	Yes
6	Apply surcharge no.5 at elev. 49.50	Yes	Yes	Yes
7	Apply surcharge no.6 at elev. 49.75	Yes	Yes	Yes
8	Apply water pressure profile no.1	Yes	Yes	Yes
9	Excav. to elev. 48.10 on RIGHT side	Yes	Yes	Yes
10	Install strut no.1 at elev. 48.40	Yes	Yes	Yes
11	Apply water pressure profile no.2	Yes	Yes	Yes
12	Excav. to elev. 43.17 on RIGHT side	Yes	Yes	Yes
13	Fill to elev. 43.65 on RIGHT side	Yes	Yes	Yes
14	Install strut no.2 at elev. 43.85	Yes	Yes	Yes
15	Change EI of wall to 43355kN.m2/m run	No	No	No
16	Change soil type 3 to soil type 4	No	No	No
17	Apply surcharge no.7 at elev. 43.65	No	No	No
18	Apply water pressure profile no.3	No	No	No
*	Summary output	Yes	-	Yes

Units: kN,m

Stage No.18 Apply water pressure profile no.3 (Worst Cred.)

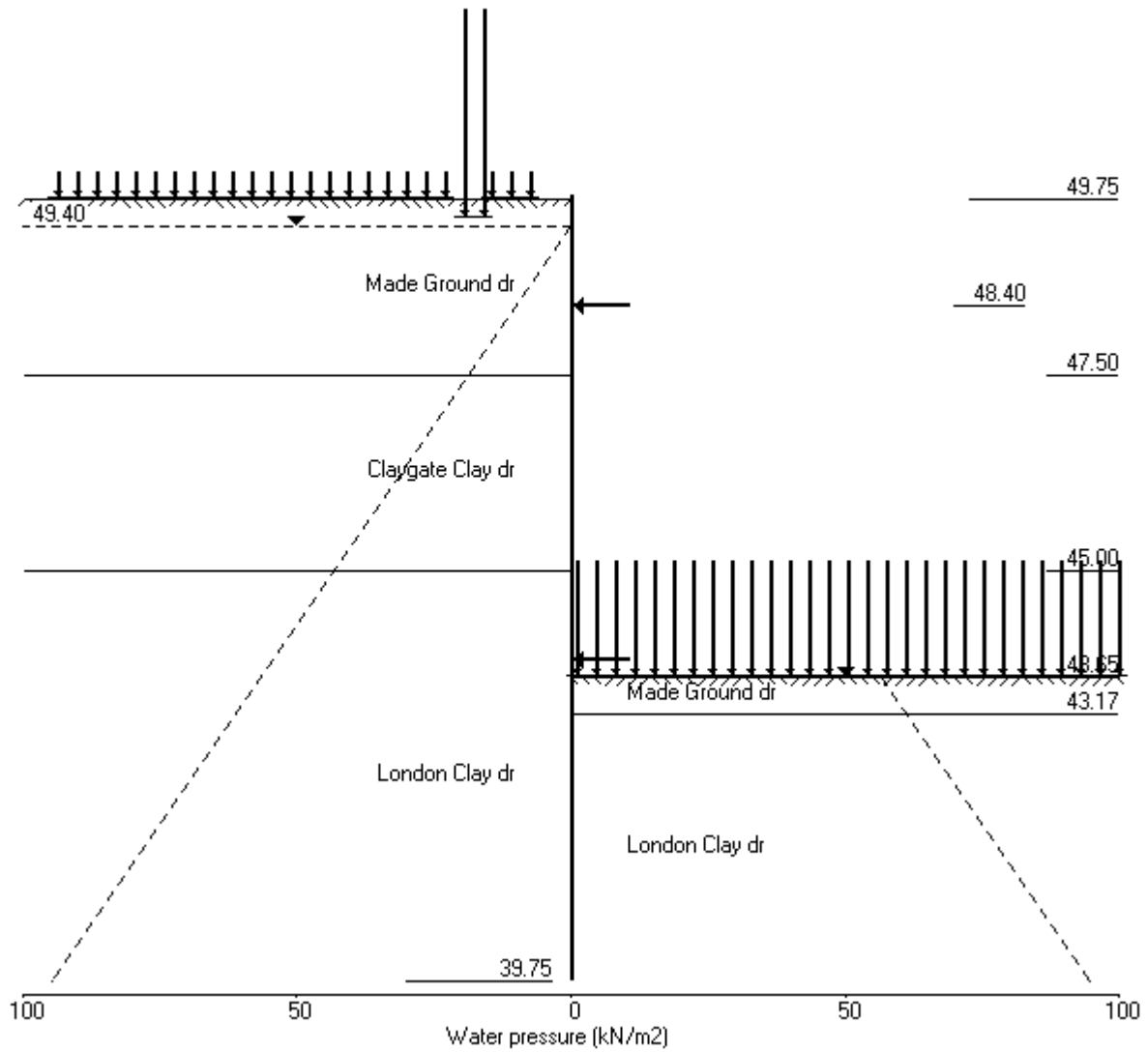

PILEDESIGNS LTD
 Program: WALLAP Version 6.06 Revision A51.B69.R54
 Licensed from GEOSOLVE
 Data filename/Run ID: Hampstead_Wall_6_450mm_rev_02_ULS2
 Hampstead - 24-26 Redington Gardens
 Wall 6, Secant-ULS2, 450 dia @ 650 - run 02

Sheet No.
 Job No. 21495
 Made by : DBS
 Date:30-11-2018
 Checked :

Units: kN,m

Stage No. 9 Excavate to elevation 48.10 on RIGHT side

STABILITY ANALYSIS of Fully Embedded Wall according to Strength Factor method
 Factor of safety on soil strength

			Overall							
			FoS for toe	Toe elev. for						
			elev. = 39.75	FoS = 1.000						

Stage No.	--- G.L. Act.	--- Pass.	Strut Elev.	Factor of Safety	Moment of equil. at elev.	Toe elev.	Wall Penetr-ation	Direction of failure		
9	49.75	48.10	Cant.	1.862	40.92	43.57	4.53	L to R		

BENDING MOMENT and DISPLACEMENT ANALYSIS of Fully Embedded Wall

Analysis options

Length of wall perpendicular to section = 50.00m
 Subgrade reaction model - Boussinesq Influence coefficients
 Soil deformations are elastic until the active or passive limit is reached
 Open Tension Crack analysis - No

Rigid boundaries: Left side 50.00 from wall
 Right side 50.00 from wall

Limit State: ULS DA1 Combination 2

*** Wall displacements reset to zero at stage 4

Node no.	Y coord	Nett pressure kN/m2	Wall disp. m	Wall rotation rad.	Shear force kN/m	Bending moment kN.m/m	Strut forces kN/m	EI of wall kN.m2/m
1	49.75	0.00	0.019	4.22E-03	0.0	-0.0		60696
2	49.50	2.04	0.018	4.22E-03	0.3	0.1		60696
3	49.40	3.03	0.018	4.22E-03	0.5	0.1		60696
4	48.90	12.16	0.015	4.21E-03	4.3	1.1		60696
5	48.40	22.06	0.013	4.19E-03	12.9	5.2		60696
6	48.10	27.45	0.012	4.15E-03	20.3	10.1		60696
7	47.50	7.94	0.010	3.97E-03	30.9	26.0		60696
		5.96	0.010	3.97E-03	30.9	26.0		
8	47.15	-1.57	0.008	3.78E-03	31.7	37.0		60696
9	46.80	-9.35	0.007	3.54E-03	29.8	47.8		60696
10	46.20	-22.99	0.005	2.99E-03	20.1	62.9		60696
11	45.60	-31.86	0.003	2.32E-03	3.6	71.4		60696
12	45.00	-17.42	0.002	1.63E-03	-11.2	69.0		60696
		-36.75	0.002	1.63E-03	-11.2	69.0		
13	44.42	-11.62	0.002	1.04E-03	-25.1	56.4		60696
14	43.85	3.41	0.001	5.91E-04	-27.4	39.9		60696
15	43.65	6.63	0.001	4.70E-04	-26.4	34.5		60696
16	43.17	11.06	0.001	2.47E-04	-22.2	22.6		60696
17	43.00	11.72	0.001	1.90E-04	-20.3	18.9		60696
18	42.50	11.77	0.001	7.26E-05	-14.4	10.2		60696
19	42.00	10.00	0.001	1.40E-05	-8.9	4.5		60696
20	41.40	6.86	0.001	-1.07E-05	-3.9	0.9		60696
21	40.80	3.52	0.001	-1.26E-05	-0.8	-0.3		60696
22	40.28	0.71	0.001	-9.98E-06	0.3	-0.2		60696
23	39.75	-2.01	0.001	-8.84E-06	-0.0	0.0		---

(continued)

Stage No.9 Excavate to elevation 48.10 on RIGHT side

Node no.	Y coord	LEFT side					Total earth pressure kN/m2	Coeff. of subgrade reaction kN/m3
		Water press. kN/m2	Vertic -al kN/m2	Effective Active limit kN/m2	Effective Passive limit kN/m2	Earth pressure kN/m2		
1	49.75	0.00	0.00	0.00	0.00	0.00	0.00	3343
2	49.50	0.00	4.99	2.04	13.28	2.04	2.04a	3343
3	49.40	0.00	7.38	3.03	19.66	3.03	3.03a	3343
4	48.90	4.90	17.69	7.26	47.13	7.26	12.16a	3343
5	48.40	9.81	29.88	12.25	79.59	12.25	22.06a	3343
6	48.10	12.75	35.83	14.70	95.44	14.70	27.45a	3343
7	47.50	18.64	44.05	18.07	117.35	18.07	36.71a	3343
		18.64	44.05	17.43	122.82	17.43	36.07a	9654
8	47.15	22.07	47.68	18.86	132.92	18.86	40.94a	9654
9	46.80	25.51	50.68	20.05	141.30	20.05	45.56a	9654
10	46.20	31.39	55.08	21.79	153.57	21.79	53.19a	9654
11	45.60	37.28	59.09	23.38	164.73	28.29	65.57	9654
12	45.00	43.16	63.00	24.92	175.63	43.16	86.33	9654
		Total>	106.16	23.75m	191.53	67.00	67.00	18530
13	44.42	Total>	116.16	26.63m	206.44	89.06	89.06	19595
14	43.85	Total>	126.25	29.50m	221.44	106.67	106.67	20661
15	43.65	Total>	129.79	30.50m	226.68	111.91	111.91	21031
16	43.17	Total>	138.33	33.69	239.32	123.05	123.05	21921
17	43.00	Total>	141.37	35.23	243.81	126.59	126.59	22236
18	42.50	Total>	150.38	39.81	257.09	136.19	136.19	23162
19	42.00	Total>	159.47	44.48	270.45	145.00	145.00	24089
20	41.40	Total>	170.48	50.18	286.58	155.16	155.16	25200
21	40.80	Total>	181.59	55.98	302.82	165.27	165.27	26312
22	40.28	Total>	191.39	61.14	317.10	174.20	174.20	27285
23	39.75	Total>	201.25	66.36	331.44	183.21	183.21	28258

Node no.	Y coord	RIGHT side					Total earth pressure kN/m2	Coeff. of subgrade reaction kN/m3
		Water press. kN/m2	Vertic -al kN/m2	Effective Active limit kN/m2	Effective Passive limit kN/m2	Earth pressure kN/m2		
1	49.75	0.00	0.00	0.00	0.00	0.00	0.00	0.0
2	49.50	0.00	0.00	0.00	0.00	0.00	0.00	0.0
3	49.40	0.00	0.00	0.00	0.00	0.00	0.00	0.0
4	48.90	0.00	0.00	0.00	0.00	0.00	0.00	0.0
5	48.40	0.00	0.00	0.00	0.00	0.00	0.00	0.0
6	48.10	0.00	0.00	0.00	0.00	0.00	0.00	0.0
		0.00	0.00	0.00	0.00	0.00	0.00	4286
7	47.50	0.00	10.80	4.43	28.77	28.77	28.77p	4286
		0.00	10.80	4.27	30.11	30.11	30.11p	12397
8	47.15	3.43	14.02	5.55	39.08	39.08	42.51p	12397
9	46.80	6.87	17.23	6.82	48.04	48.04	54.91p	12397
10	46.20	12.75	22.75	9.00	63.42	63.42	76.17p	12397
11	45.60	18.64	28.26	11.18	78.79	78.79	97.43p	12397
12	45.00	24.52	33.78	13.36	94.17	79.23	103.75	12397
		Total>	58.30	15.50m	143.67	103.75	103.75	23421
13	44.42	Total>	69.80	18.37m	160.08	100.68	100.68	24768
14	43.85	Total>	81.31	21.25m	176.49	103.26	103.26	26115
15	43.65	Total>	85.31	22.25m	182.20	105.28	105.28	26583
16	43.17	Total>	94.91	24.65m	195.90	111.99	111.99	27707
17	43.00	Total>	98.31	25.50m	200.75	114.87	114.87	28105
18	42.50	Total>	108.32	28.00m	215.03	124.42	124.42	29277
19	42.00	Total>	118.32	30.50m	229.30	135.00	135.00	30448
20	41.40	Total>	130.33	33.50m	246.43	148.30	148.30	31853

(continued)

Stage No.9 Excavate to elevation 48.10 on RIGHT side

Node no.	Y coord	----- RIGHT side -----					Total earth pressure	Coeff. of subgrade reaction
		Water press. kN/m2	Vertic -al kN/m2	Active limit kN/m2	Passive limit kN/m2	Earth pressure kN/m2		
21	40.80	Total>	142.34	36.50m	263.56	161.75	161.75	33258
22	40.28	Total>	152.85	39.12m	278.55	173.49	173.49	34488
23	39.75	Total>	163.36	41.75m	293.54	185.22	185.22	35717

Note: 53.19a Soil pressure at active limit
 97.43p Soil pressure at passive limit

Units: kN,m

Stage No.9 Excav. to elev. 48.10 on RIGHT side

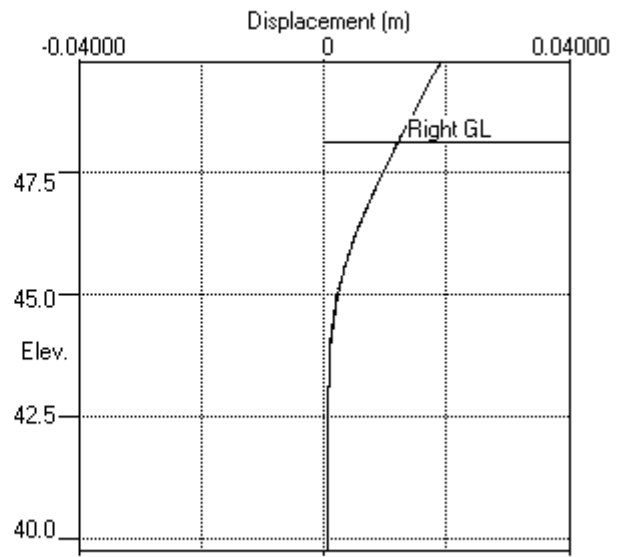
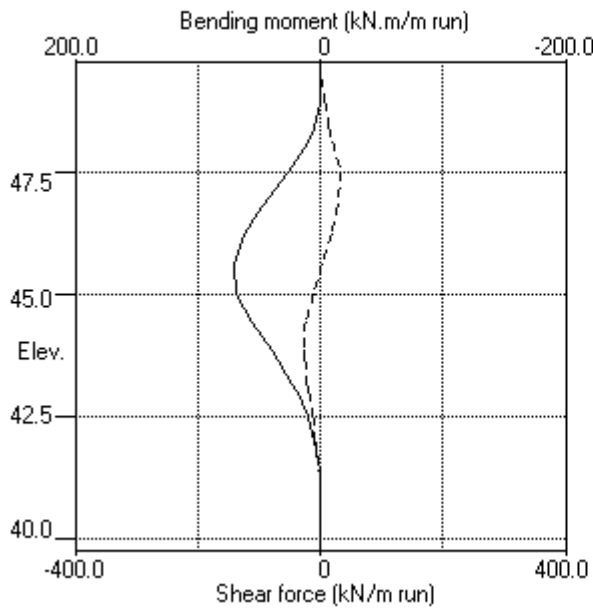

Stage No.9 Excav. to elev. 48.10 on RIGHT side

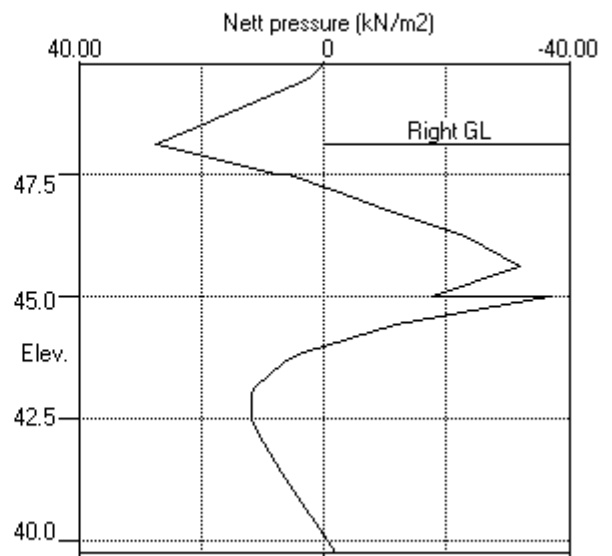
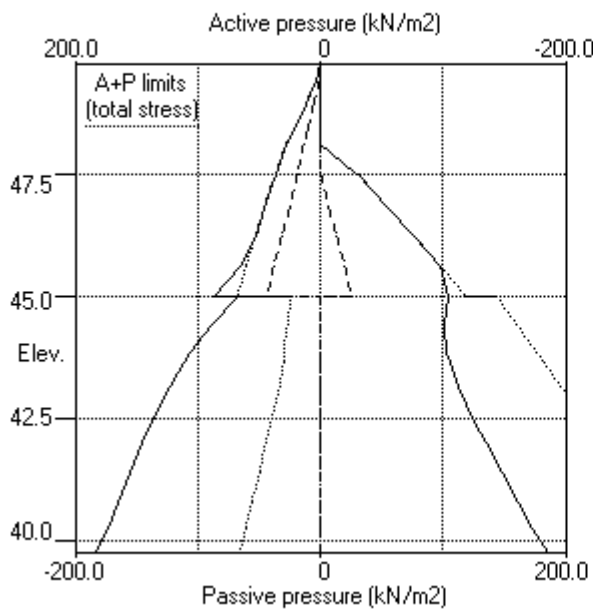

PILEDESIGNS LTD
 Program: WALLAP Version 6.06 Revision A51.B69.R54
 Licensed from GEOSOLVE
 Data filename/Run ID: Hampstead_Wall_6_450mm_rev_02_ULS2
 Hampstead - 24-26 Redington Gardens
 Wall 6, Secant-ULS2, 450 dia @ 650 - run 02

Sheet No.
 Job No. 21495
 Made by : DBS
 Date: 30-11-2018
 Checked :

Units: kN,m

Stage No. 12 Excavate to elevation 43.17 on RIGHT side

STABILITY ANALYSIS of Fully Embedded Wall according to Strength Factor method
 Factor of safety on soil strength

			Overall					
			FoS for toe		Toe elev. for			
			elev. = 39.75		FoS = 1.000			

Stage No.	--- G.L. Act.	--- Pass.	Strut Elev.	Factor of Safety	Moment of equil. at elev.	Toe elev.	Wall Penetr-ation	Direction of failure
12	49.75	43.17	48.40	1.417	n/a	42.01	1.16	L to R

BENDING MOMENT and DISPLACEMENT ANALYSIS of Fully Embedded Wall

Analysis options

Length of wall perpendicular to section = 50.00m
 Subgrade reaction model - Boussinesq Influence coefficients
 Soil deformations are elastic until the active or passive limit is reached
 Open Tension Crack analysis - No

Rigid boundaries: Left side 50.00 from wall
 Right side 50.00 from wall

Limit State: ULS DA1 Combination 2

*** Wall displacements reset to zero at stage 4

Node no.	Y coord	Nett pressure kN/m2	Wall disp. m	Wall rotation rad.	Shear force kN/m	Bending moment kN.m/m	Strut forces kN/m	EI of wall kN.m2/m
1	49.75	0.00	0.009	-3.13E-03	0.0	-0.0		60696
2	49.50	13.28	0.010	-3.13E-03	1.7	0.2		60696
3	49.40	19.66	0.010	-3.13E-03	3.3	0.4		60696
4	48.90	37.94	0.012	-3.15E-03	17.7	4.3		60696
5	48.40	22.06	0.014	-3.24E-03	32.7	18.3	142.1	60696
		22.06	0.014	-3.24E-03	-109.3	18.3		
6	48.10	27.45	0.015	-3.26E-03	-101.9	-13.5		60696
7	47.50	36.71	0.016	-2.85E-03	-82.7	-69.2		60696
		36.07	0.016	-2.85E-03	-82.7	-69.2		
8	47.15	40.94	0.017	-2.38E-03	-69.2	-95.8		60696
9	46.80	45.56	0.018	-1.76E-03	-54.1	-117.4		60696
10	46.20	53.19	0.019	-4.91E-04	-24.4	-141.4		60696
11	45.60	60.66	0.019	9.22E-04	9.7	-144.8		60696
12	45.00	68.09	0.018	2.26E-03	48.3	-127.4		60696
		23.75	0.018	2.26E-03	48.3	-127.4		
13	44.42	26.63	0.016	3.33E-03	62.8	-97.1		60696
14	43.85	29.50	0.014	4.06E-03	79.0	-57.4		60696
15	43.65	30.50	0.013	4.23E-03	85.0	-41.0		60696
16	43.17	33.69	0.011	4.38E-03	100.4	3.1		60696
		-67.29	0.011	4.38E-03	100.4	3.1		
17	43.00	-70.60	0.010	4.35E-03	88.6	19.2		60696
18	42.50	-80.29	0.008	4.05E-03	50.9	54.2		60696
19	42.00	-77.59	0.006	3.53E-03	11.4	73.4		60696
20	41.40	-56.76	0.004	2.84E-03	-28.9	66.0		60696
21	40.80	-12.78	0.003	2.30E-03	-49.7	44.1		60696
22	40.28	42.28	0.002	2.04E-03	-42.0	16.2		60696
23	39.75	117.62	0.001	1.97E-03	-0.0	0.0		---
At elev. 48.40 Strut force =			142.1 kN/strut =			142.1 kN/m run		

(continued)

Stage No.12 Excavate to elevation 43.17 on RIGHT side

Node no.	Y coord	LEFT side					Total earth pressure	Coeff. of subgrade reaction
		Water press. kN/m2	Vertic -al kN/m2	Effective Active limit kN/m2	Effective Passive limit kN/m2	Earth pressure kN/m2		
1	49.75	0.00	0.00	0.00	0.00	0.00	0.00	7300
2	49.50	0.00	4.99	2.04	13.28	13.28	13.28p	7300
3	49.40	0.00	7.38	3.03	19.66	19.66	19.66p	7300
4	48.90	4.90	17.69	7.26	47.13	33.04	37.94	7300
5	48.40	9.81	29.88	12.25	79.59	12.25	22.06a	2122
6	48.10	12.75	35.83	14.70	95.44	14.70	27.45a	2122
7	47.50	18.64	44.05	18.07	117.35	18.07	36.71a	2122
		18.64	44.05	17.43	122.82	17.43	36.07a	6098
8	47.15	22.07	47.68	18.86	132.92	18.86	40.94a	6098
9	46.80	25.51	50.68	20.05	141.30	20.05	45.56a	6098
10	46.20	31.39	55.08	21.79	153.57	21.79	53.19a	6098
11	45.60	37.28	59.09	23.38	164.73	23.38	60.66a	6098
12	45.00	43.16	63.00	24.92	175.63	24.92	68.09a	6098
		Total>	106.16	23.75m	191.53	23.75	23.75a	12254
13	44.42	Total>	116.16	26.63m	206.44	26.63	26.63a	12959
14	43.85	Total>	126.25	29.50m	221.44	29.50	29.50a	13663
15	43.65	Total>	129.79	30.50m	226.68	30.50	30.50a	13909
16	43.17	Total>	138.33	33.69	239.32	33.69	33.69a	14497
17	43.00	Total>	141.37	35.23	243.81	35.23	35.23a	14705
18	42.50	Total>	150.38	39.81	257.09	39.81	39.81a	15318
19	42.00	Total>	159.47	44.48	270.45	56.77	56.77	15931
20	41.40	Total>	170.48	50.18	286.58	94.73	94.73	16666
21	40.80	Total>	181.59	55.98	302.82	129.00	129.00	17401
22	40.28	Total>	191.39	61.14	317.10	157.08	157.08	18044
23	39.75	Total>	201.25	66.36	331.44	191.96	191.96	74941

Node no.	Y coord	RIGHT side					Total earth pressure	Coeff. of subgrade reaction
		Water press. kN/m2	Vertic -al kN/m2	Effective Active limit kN/m2	Effective Passive limit kN/m2	Earth pressure kN/m2		
1	49.75	0.00	0.00	0.00	0.00	0.00	0.00	0.0
2	49.50	0.00	0.00	0.00	0.00	0.00	0.00	0.0
3	49.40	0.00	0.00	0.00	0.00	0.00	0.00	0.0
4	48.90	0.00	0.00	0.00	0.00	0.00	0.00	0.0
5	48.40	0.00	0.00	0.00	0.00	0.00	0.00	0.0
6	48.10	0.00	0.00	0.00	0.00	0.00	0.00	0.0
7	47.50	0.00	0.00	0.00	0.00	0.00	0.00	0.0
8	47.15	0.00	0.00	0.00	0.00	0.00	0.00	0.0
9	46.80	0.00	0.00	0.00	0.00	0.00	0.00	0.0
10	46.20	0.00	0.00	0.00	0.00	0.00	0.00	0.0
11	45.60	0.00	0.00	0.00	0.00	0.00	0.00	0.0
12	45.00	0.00	0.00	0.00	0.00	0.00	0.00	0.0
13	44.42	0.00	0.00	0.00	0.00	0.00	0.00	0.0
14	43.85	0.00	0.00	0.00	0.00	0.00	0.00	0.0
15	43.65	0.00	0.00	0.00	0.00	0.00	0.00	0.0
16	43.17	0.00	0.00	0.00	0.00	0.00	0.00	0.0
		Total>	0.00	0.00	100.98	100.98	100.98p	29385
17	43.00	Total>	3.40	0.85m	105.83	105.83	105.83p	29807
18	42.50	Total>	13.40	3.35m	120.10	120.10	120.10p	31049
19	42.00	Total>	23.40	5.85m	134.37	134.37	134.37p	32291
20	41.40	Total>	35.40	8.85m	151.49	151.49	151.49p	33782
21	40.80	Total>	47.41	11.85m	168.62	141.78	141.78	35272
22	40.28	Total>	57.91	14.47m	183.60	114.80	114.80	36576

Run ID. Hampstead_Wall_6_450mm_rev_02_ULS2
 Hampstead - 24-26 Redington Gardens
 Wall 6, Secant-ULS2, 450 dia @ 650 - run 02

| Sheet No.
 | Date:30-11-2018
 | Checked :

(continued)

Stage No.12 Excavate to elevation 43.17 on RIGHT side

Node no.	Y coord	----- RIGHT side -----					Total earth pressure kN/m2	Coeff. of subgrade reaction kN/m3
		Water press. kN/m2	Vertic -al kN/m2	Effective Active limit kN/m2	Effective Passive limit kN/m2	Earth pressure kN/m2		
23	39.75	Total>	68.42	17.10m	198.59	74.34	74.34	150723

Note: 39.81a Soil pressure at active limit
 151.49p Soil pressure at passive limit

Units: kN,m

Stage No.12 Excav. to elev. 43.17 on RIGHT side

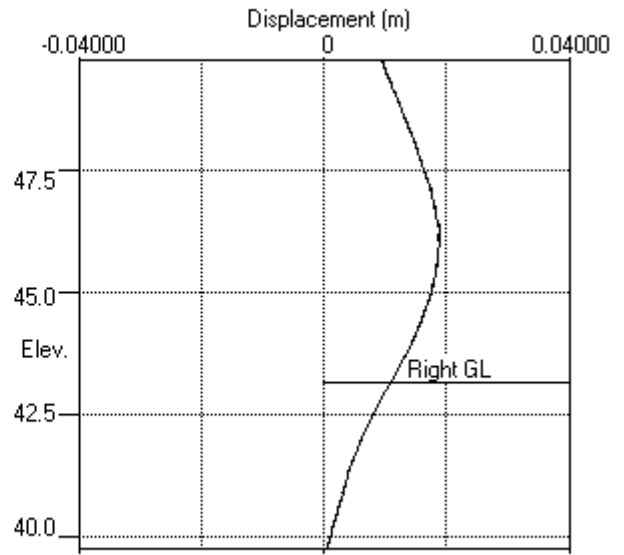
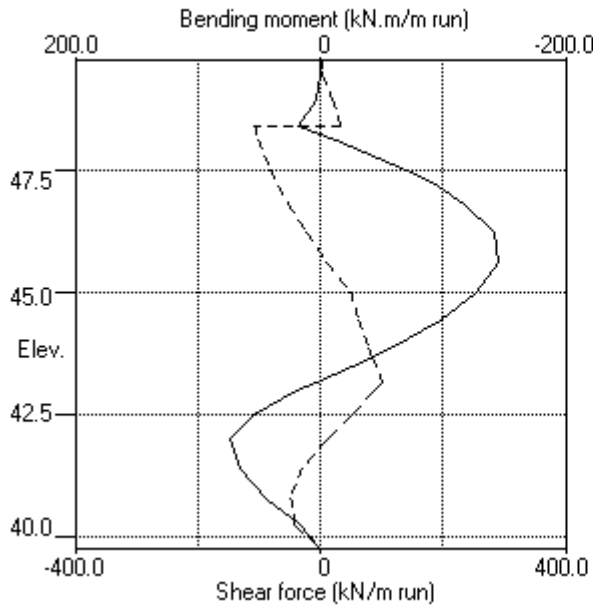

Stage No.12 Excav. to elev. 43.17 on RIGHT side

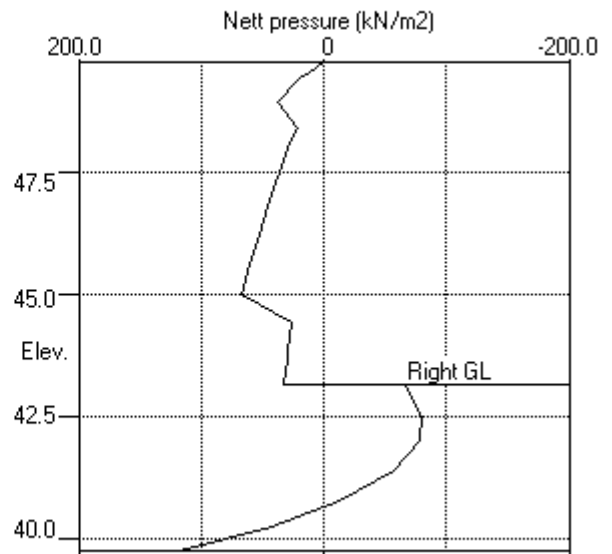
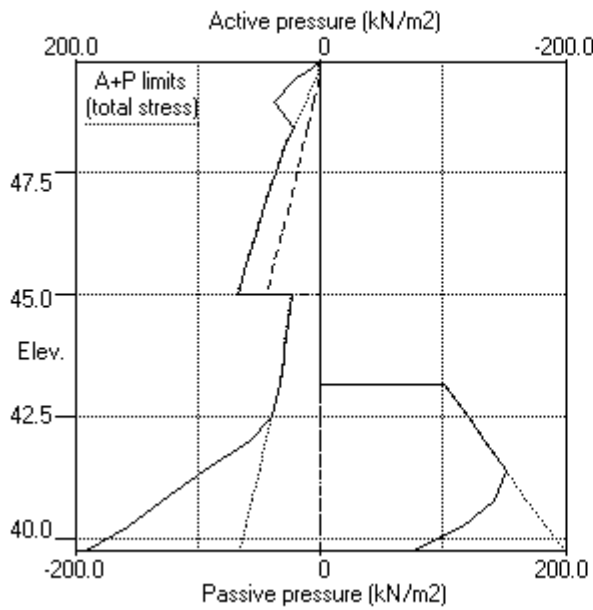

PILEDESIGNS LTD
 Program: WALLAP Version 6.06 Revision A51.B69.R54
 Licensed from GEOSOLVE
 Data filename/Run ID: Hampstead_Wall_6_450mm_rev_02_ULS2
 Hampstead - 24-26 Redington Gardens
 Wall 6, Secant-ULS2, 450 dia @ 650 - run 02

Sheet No.
 Job No. 21495
 Made by : DBS
 Date:30-11-2018
 Checked :

Units: kN,m

Stage No. 13 Fill to elevation 43.65 on RIGHT side with soil type 1

STABILITY ANALYSIS of Fully Embedded Wall according to Strength Factor method
 Factor of safety on soil strength

			Overall					
			FoS for toe		Toe elev. for			
			elev. = 39.75		FoS = 1.000			

Stage No.	--- G.L. Act.	--- Pass.	Strut Elev.	Factor of Safety	Moment of equil. at elev.	Toe elev.	Wall Penetr-ation	Direction of failure
13	49.75	43.65	48.40	1.490	n/a	42.16	1.49	L to R

BENDING MOMENT and DISPLACEMENT ANALYSIS of Fully Embedded Wall

Analysis options

Length of wall perpendicular to section = 50.00m
 Subgrade reaction model - Boussinesq Influence coefficients
 Soil deformations are elastic until the active or passive limit is reached
 Open Tension Crack analysis - No

Rigid boundaries: Left side 50.00 from wall
 Right side 50.00 from wall

Limit State: ULS DA1 Combination 2

*** Wall displacements reset to zero at stage 4

Node no.	Y coord	Nett pressure kN/m2	Wall disp. m	Wall rotation rad.	Shear force kN/m	Bending moment kN.m/m	Strut forces kN/m	EI of wall kN.m2/m
1	49.75	0.00	0.009	-3.12E-03	0.0	-0.0		60696
2	49.50	13.24	0.010	-3.12E-03	1.7	0.2		60696
3	49.40	19.63	0.010	-3.12E-03	3.3	0.4		60696
4	48.90	37.92	0.012	-3.14E-03	17.7	4.3		60696
5	48.40	22.06	0.014	-3.24E-03	32.7	18.2	142.4	60696
		22.06	0.014	-3.24E-03	-109.8	18.2		
6	48.10	27.45	0.015	-3.25E-03	-102.3	-13.6		60696
7	47.50	36.72	0.016	-2.84E-03	-83.1	-69.6		60696
		36.10	0.016	-2.84E-03	-83.1	-69.6		
8	47.15	40.99	0.017	-2.37E-03	-69.6	-96.3		60696
9	46.80	45.64	0.018	-1.75E-03	-54.4	-118.1		60696
10	46.20	53.34	0.019	-4.69E-04	-24.7	-142.3		60696
11	45.60	60.92	0.019	9.53E-04	9.5	-145.8		60696
12	45.00	68.49	0.018	2.31E-03	48.4	-128.5		60696
		24.56	0.018	2.31E-03	48.4	-128.5		
13	44.42	27.85	0.016	3.38E-03	63.4	-98.0		60696
14	43.85	31.26	0.014	4.12E-03	80.4	-57.8		60696
15	43.65	32.46	0.013	4.29E-03	86.8	-41.1		60696
16	43.17	32.61	0.011	4.44E-03	102.4	4.0		60696
		-70.57	0.011	4.44E-03	102.4	4.0		
17	43.00	-73.52	0.010	4.40E-03	90.2	20.4		60696
18	42.50	-82.20	0.008	4.09E-03	51.2	55.8		60696
19	42.00	-78.65	0.006	3.56E-03	11.0	74.9		60696
20	41.40	-57.02	0.004	2.85E-03	-29.7	67.1		60696
21	40.80	-12.44	0.003	2.30E-03	-50.5	44.7		60696
22	40.28	43.05	0.001	2.04E-03	-42.5	16.4		60696
23	39.75	118.79	0.000	1.97E-03	-0.0	0.0		---
At elev. 48.40 Strut force =			142.4 kN/strut =			142.4 kN/m run		

(continued)

Stage No.13 Fill to elevation 43.65 on RIGHT side with soil type 1

Node no.	Y coord	LEFT side					Total earth pressure	Coeff. of subgrade reaction
		Water press. kN/m2	Vertic -al kN/m2	Effective Active limit kN/m2	Effective Passive limit kN/m2	Earth pressure kN/m2		
1	49.75	0.00	0.00	0.00	0.00	0.00	0.00	6846
2	49.50	0.00	4.99	2.04	13.28	13.24	13.24	6846
3	49.40	0.00	7.38	3.03	19.66	19.63	19.63	6846
4	48.90	4.90	17.69	7.26	47.13	33.02	37.92	6846
5	48.40	9.81	29.88	12.25	79.59	12.25	22.06a	6846
6	48.10	12.75	35.83	14.70	95.44	14.70	27.45a	2283
7	47.50	18.64	44.05	18.07	117.35	18.08	36.72	2283
		18.64	44.05	17.43	122.82	17.46	36.10	6567
8	47.15	22.07	47.68	18.86	132.92	18.92	40.99	6567
9	46.80	25.51	50.68	20.05	141.30	20.14	45.64	6567
10	46.20	31.39	55.08	21.79	153.57	21.95	53.34	6567
11	45.60	37.28	59.09	23.38	164.73	23.64	60.92	6567
12	45.00	43.16	63.00	24.92	175.63	25.33	68.49	6567
		Total>	106.16	23.75m	191.53	24.56	24.56	13070
13	44.42	Total>	116.16	26.63m	206.44	27.85	27.85	13822
14	43.85	Total>	126.25	29.50m	221.44	31.26	31.26	14573
15	43.65	Total>	129.79	30.50m	226.68	32.46	32.46	14834
16	43.17	Total>	138.33	33.69	239.32	36.16	36.16	15462
17	43.00	Total>	141.37	35.23	243.81	37.88	37.88	15684
18	42.50	Total>	150.38	39.81	257.09	42.96	42.96	16338
19	42.00	Total>	159.47	44.48	270.45	60.34	60.34	16991
20	41.40	Total>	170.48	50.18	286.58	98.69	98.69	17775
21	40.80	Total>	181.59	55.98	302.82	133.25	133.25	18559
22	40.28	Total>	191.39	61.14	317.10	161.55	161.55	19246
23	39.75	Total>	201.25	66.36	331.44	196.63	196.63	19932

Node no.	Y coord	RIGHT side					Total earth pressure	Coeff. of subgrade reaction
		Water press. kN/m2	Vertic -al kN/m2	Effective Active limit kN/m2	Effective Passive limit kN/m2	Earth pressure kN/m2		
1	49.75	0.00	0.00	0.00	0.00	0.00	0.00	0.0
2	49.50	0.00	0.00	0.00	0.00	0.00	0.00	0.0
3	49.40	0.00	0.00	0.00	0.00	0.00	0.00	0.0
4	48.90	0.00	0.00	0.00	0.00	0.00	0.00	0.0
5	48.40	0.00	0.00	0.00	0.00	0.00	0.00	0.0
6	48.10	0.00	0.00	0.00	0.00	0.00	0.00	0.0
7	47.50	0.00	0.00	0.00	0.00	0.00	0.00	0.0
8	47.15	0.00	0.00	0.00	0.00	0.00	0.00	0.0
9	46.80	0.00	0.00	0.00	0.00	0.00	0.00	0.0
10	46.20	0.00	0.00	0.00	0.00	0.00	0.00	0.0
11	45.60	0.00	0.00	0.00	0.00	0.00	0.00	0.0
12	45.00	0.00	0.00	0.00	0.00	0.00	0.00	0.0
13	44.42	0.00	0.00	0.00	0.00	0.00	0.00	0.0
14	43.85	0.00	0.00	0.00	0.00	0.00	0.00	0.0
15	43.65	0.00	0.00	0.00	0.00	0.00	0.00	0.0
		0.00	0.00	0.00	0.00	0.00	0.00	2362
16	43.17	0.00	8.64	3.54	23.02	3.54	3.54a	2362
		Total>	8.64	2.40m	109.62	106.73	106.73	15941
17	43.00	Total>	12.04	3.25m	114.47	111.39	111.39	16170
18	42.50	Total>	22.04	5.75m	128.74	125.15	125.15	16844
19	42.00	Total>	32.04	8.25m	143.01	138.99	138.99	17518
20	41.40	Total>	44.04	11.25m	160.13	155.71	155.71	18326
21	40.80	Total>	56.05	14.25m	177.26	145.69	145.69	19135

Run ID. Hampstead_Wall_6_450mm_rev_02_ULS2
 Hampstead - 24-26 Redington Gardens
 Wall 6, Secant-ULS2, 450 dia @ 650 - run 02

| Sheet No.
 | Date:30-11-2018
 | Checked :

(continued)

Stage No.13 Fill to elevation 43.65 on RIGHT side with soil type 1

Node no.	Y coord	----- RIGHT side -----					Total earth pressure	Coeff. of subgrade reaction
		Water press. kN/m2	Vertical kN/m2	Effective Active limit kN/m2	Effective Passive limit kN/m2	Earth pressure kN/m2		
22	40.28	Total>	66.55	16.88m	192.25	118.50	118.50	19842
23	39.75	Total>	77.06	19.50m	207.24	77.83	77.83	20550

Note: 3.54a Soil pressure at active limit
 123.45p Soil pressure at passive limit

Units: kN,m

Stage No.13 Fill to elev. 43.65 on RIGHT side

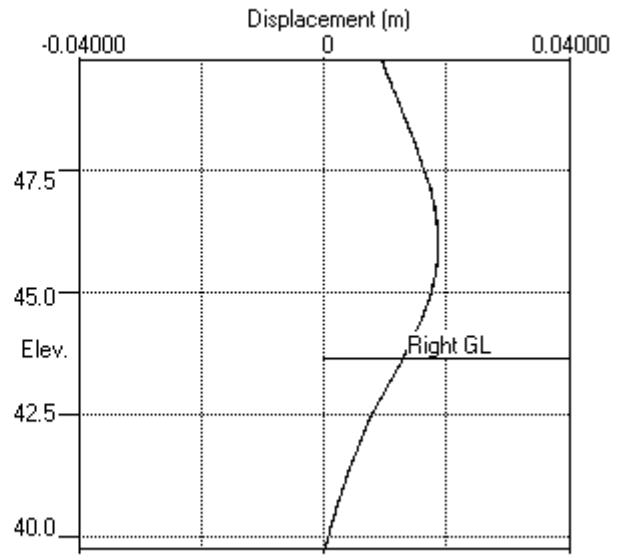
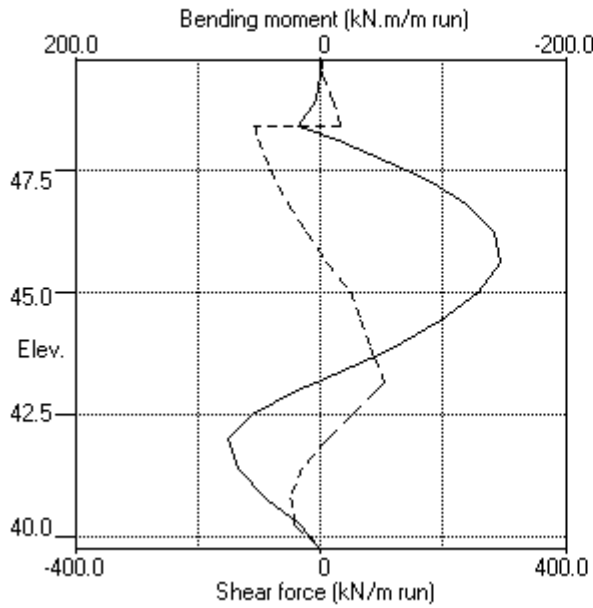

Stage No.13 Fill to elev. 43.65 on RIGHT side

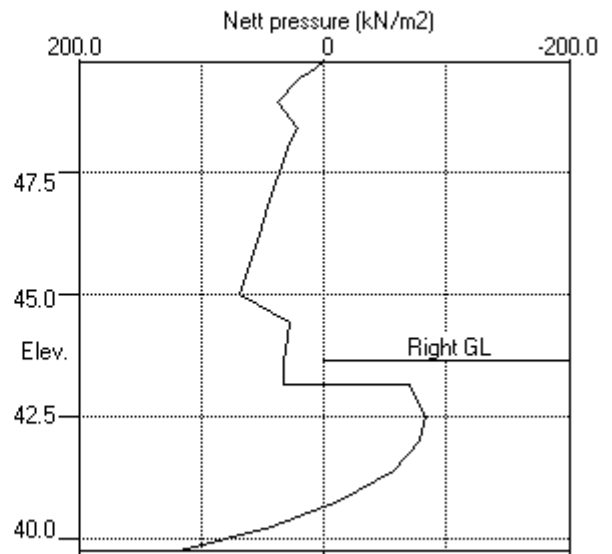
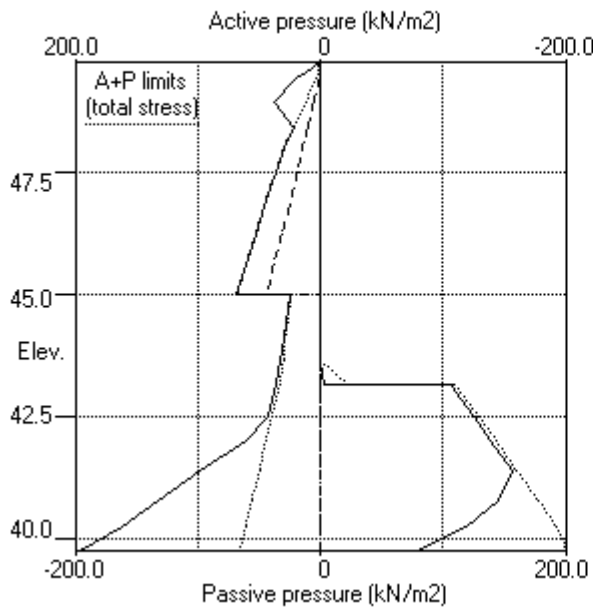

PILEDESIGNS LTD
 Program: WALLAP Version 6.06 Revision A51.B69.R54
 Licensed from GEOSOLVE
 Data filename/Run ID: Hampstead_Wall_6_450mm_rev_02_ULS2
 Hampstead - 24-26 Redington Gardens
 Wall 6, Secant-ULS2, 450 dia @ 650 - run 02

Sheet No.
 Job No. 21495
 Made by : DBS
 Date: 30-11-2018
 Checked :

Units: kN,m

Stage No. 15 Change EI of wall to 43355 kN.m2/m run
 Yield moment not defined
 Allow wall to relax with new modulus value

STABILITY ANALYSIS of Fully Embedded Wall according to Strength Factor method
 Factor of safety on soil strength

		Overall					
		FoS for toe		Toe elev. for			
		elev. = 39.75		FoS = 1.000			
		-----		-----			
Stage No.	--- G.L. --- Act. Pass.	Strut Elev.	Factor of Safety	Moment of equil. at elev.	Toe elev.	Wall Penetr -ation	Direction of failure
15	49.75 43.65		More than one strut.	No FoS calc.			

BENDING MOMENT and DISPLACEMENT ANALYSIS of Fully Embedded Wall

Analysis options

Length of wall perpendicular to section = 50.00m
 Subgrade reaction model - Boussinesq Influence coefficients
 Soil deformations are elastic until the active or passive limit is reached
 Open Tension Crack analysis - No

Rigid boundaries: Left side 50.00 from wall
 Right side 50.00 from wall

Limit State: ULS DA1 Combination 2

*** Wall displacements reset to zero at stage 4

Node no.	Y coord	Nett pressure kN/m2	Wall disp. m	Wall rotation rad.	Shear force kN/m	Bending moment kN.m/m	Strut forces kN/m	EI of wall kN.m2/m
1	49.75	0.00	0.008	-3.77E-03	0.0	-0.0		43355
2	49.50	13.28	0.009	-3.77E-03	1.7	0.2		43355
3	49.40	19.66	0.010	-3.77E-03	3.3	0.4		43355
4	48.90	40.36	0.012	-3.80E-03	18.3	4.3		43355
5	48.40	22.11	0.014	-3.94E-03	33.9	18.8	136.6	43355
		22.11	0.014	-3.94E-03	-102.7	18.8		
6	48.10	27.45	0.015	-3.96E-03	-95.2	-11.4		43355
7	47.50	36.71	0.017	-3.46E-03	-76.0	-64.0		43355
		36.07	0.017	-3.46E-03	-76.0	-64.0		
8	47.15	40.94	0.018	-2.86E-03	-62.5	-88.9		43355
9	46.80	45.56	0.019	-2.08E-03	-47.4	-108.7		43355
10	46.20	53.19	0.020	-4.84E-04	-17.8	-129.7		43355
11	45.60	60.66	0.020	1.25E-03	16.4	-130.0		43355
12	45.00	68.09	0.018	2.84E-03	55.0	-109.6		43355
		23.75	0.018	2.84E-03	55.0	-109.6		
13	44.42	26.63	0.016	4.00E-03	69.5	-76.2		43355
14	43.85	30.57	0.014	4.64E-03	85.9	-33.4	33.4	43355
		30.57	0.014	4.64E-03	52.5	-33.4		
15	43.65	33.60	0.013	4.74E-03	58.9	-21.1		43355
16	43.17	37.54	0.011	4.74E-03	76.0	13.8		43355
		-60.72	0.011	4.74E-03	76.0	13.8		
17	43.00	-61.58	0.010	4.65E-03	65.6	26.8		43355
18	42.50	-66.13	0.008	4.18E-03	33.7	53.8		43355
19	42.00	-61.63	0.006	3.50E-03	1.7	67.6		43355
20	41.40	-42.96	0.004	2.66E-03	-29.6	57.9		43355
21	40.80	-4.74	0.002	2.04E-03	-43.9	37.5		43355
22	40.28	43.83	0.001	1.75E-03	-33.7	12.7		43355

(continued)

Stage No.15 Change EI of wall to 43355 kN.m2/m run
 Yield moment not defined
 Allow wall to relax with new modulus value

Node no.	Y coord	RIGHT side						
		Water press. kN/m2	Vertic -al kN/m2	Effective Active limit kN/m2	Effective Passive limit kN/m2	Earth pressure kN/m2	Total earth pressure kN/m2	Coeff. of subgrade reaction kN/m3
15	43.65	0.00	0.00	0.00	0.00	0.00	0.00	0.0
16	43.17	0.00	8.64	3.54	23.02	3.54	3.54a	3143
		Total>	8.64	2.40m	109.62	101.81	101.81	20694
17	43.00	Total>	12.04	3.25m	114.47	105.43	105.43	20991
18	42.50	Total>	22.04	5.75m	128.74	117.12	117.12	21866
19	42.00	Total>	32.04	8.25m	143.01	130.48	130.48	22740
20	41.40	Total>	44.04	11.25m	160.13	148.68	148.68	23790
21	40.80	Total>	56.05	14.25m	177.26	141.84	141.84	24839
22	40.28	Total>	66.55	16.88m	192.25	118.11	118.11	54141
23	39.75	Total>	77.06	19.50m	207.24	94.99	94.99	119016

Note: 3.54a Soil pressure at active limit
 19.66p Soil pressure at passive limit

Units: kN,m

Stage No.15 Change EI of wall to 43355kN.m²/m run

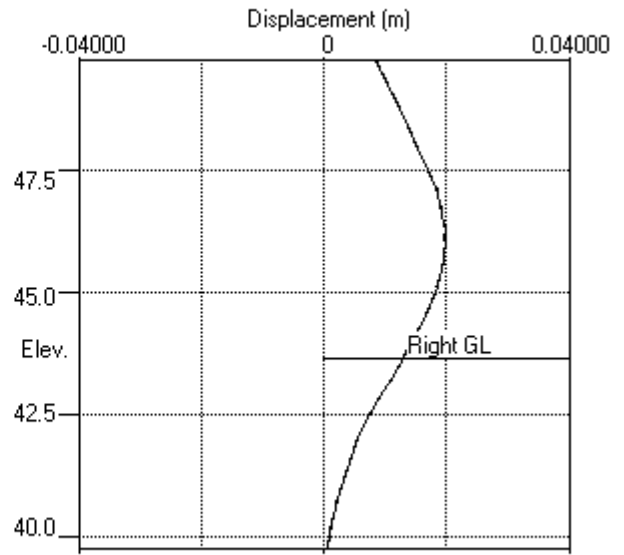
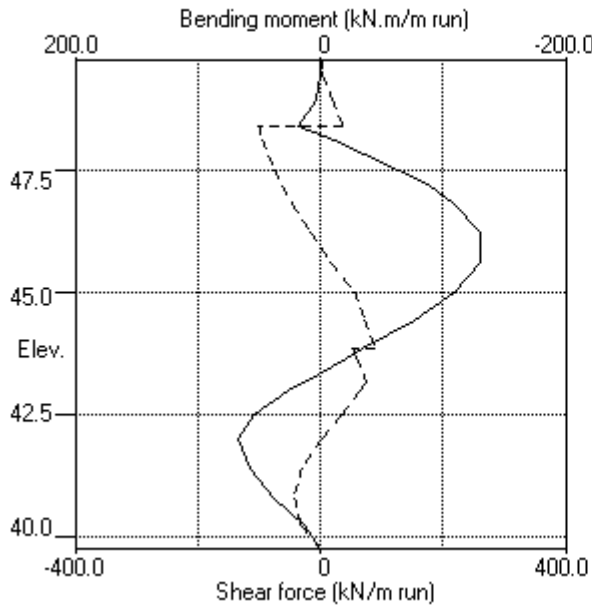

Stage No.15 Change EI of wall to 43355kN.m²/m run

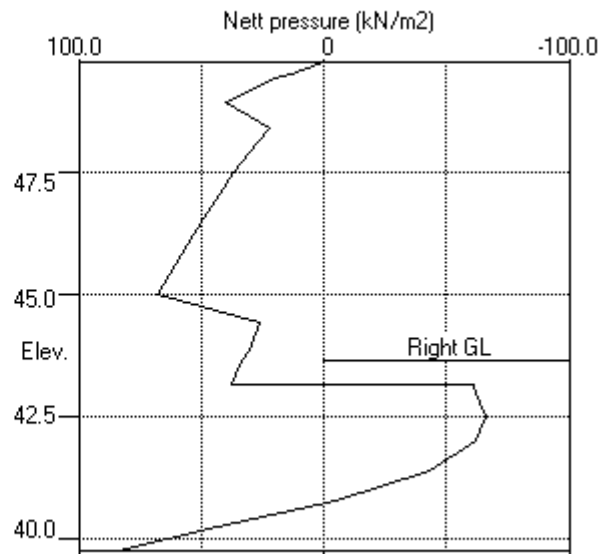
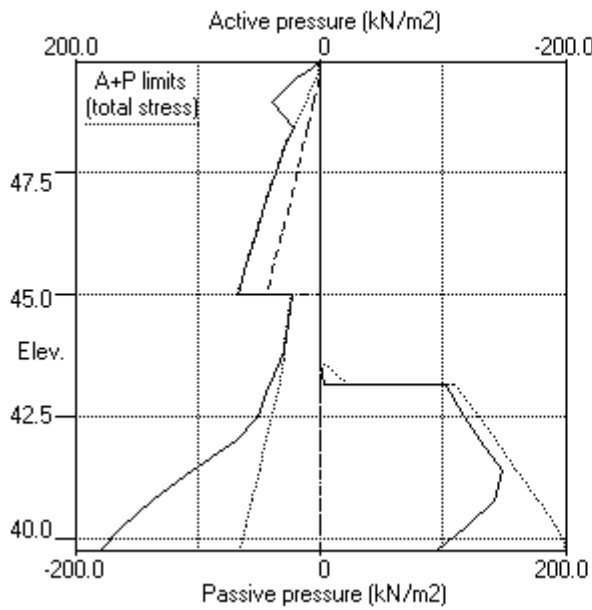

Units: kN,m

Stage No. 16 Change properties of soil type 3 to soil type 4
Ko pressures will not be reset

STABILITY ANALYSIS of Fully Embedded Wall according to Strength Factor method
Factor of safety on soil strength

			Overall				
			FoS for toe	Toe elev. for			
			elev. = 39.75	FoS = 1.000			
Stage	--- G.L. ---	Strut	Factor	Moment	Toe	Wall	Direction
No.	Act. Pass.	Elev.	of	equilib.	elev.	Penetr	of
			Safety	at elev.		-ation	failure
16	49.75 43.65		More than one strut.	No FoS calc.			

BENDING MOMENT and DISPLACEMENT ANALYSIS of Fully Embedded Wall

Analysis options

Length of wall perpendicular to section = 50.00m

Subgrade reaction model - Boussinesq Influence coefficients

Soil deformations are elastic until the active or passive limit is reached

Open Tension Crack analysis - No

Rigid boundaries: Left side 50.00 from wall

Right side 50.00 from wall

Limit State: ULS DA1 Combination 2

*** Wall displacements reset to zero at stage 4

Node no.	Y coord	Nett pressure kN/m2	Wall disp. m	Wall rotation rad.	Shear force kN/m	Bending moment kN.m/m	Strut forces kN/m	EI of wall kN.m2/m
1	49.75	0.00	0.010	-2.32E-03	0.0	-0.0		43355
2	49.50	2.04	0.011	-2.32E-03	0.3	0.1		43355
3	49.40	9.16	0.011	-2.32E-03	0.8	0.1		43355
4	48.90	35.14	0.012	-2.33E-03	11.9	1.4		43355
5	48.40	22.19	0.013	-2.41E-03	26.2	12.1	114.1	43355
		22.19	0.013	-2.41E-03	-87.9	12.1		
6	48.10	28.80	0.014	-2.41E-03	-80.2	-13.7		43355
7	47.50	40.62	0.016	-1.94E-03	-59.4	-57.1		43355
		47.36	0.016	-1.94E-03	-59.4	-57.1		
8	47.15	56.36	0.016	-1.42E-03	-41.3	-75.4		43355
9	46.80	64.81	0.017	-7.87E-04	-20.1	-86.9		43355
10	46.20	77.69	0.017	3.76E-04	22.7	-88.0		43355
11	45.60	87.57	0.016	1.34E-03	72.3	-59.6		43355
12	45.00	92.67	0.015	1.69E-03	126.4	-0.8		43355
		69.95	0.015	1.69E-03	126.4	-0.8		
13	44.42	77.44	0.014	1.08E-03	168.7	81.4		43355
14	43.85	84.97	0.014	-8.01E-04	215.4	189.9	377.8	43355
		84.97	0.014	-8.01E-04	-162.4	189.9		
15	43.65	87.60	0.014	-1.63E-03	-145.2	160.3		43355
16	43.17	73.56	0.016	-3.14E-03	-106.5	103.4		43355
		71.93	0.016	-3.14E-03	-106.5	103.4		
17	43.00	65.52	0.016	-3.52E-03	-94.8	87.3		43355
18	42.50	54.28	0.018	-4.31E-03	-64.8	49.7		43355
19	42.00	43.08	0.020	-4.75E-03	-40.5	28.7		43355
20	41.40	29.68	0.023	-4.98E-03	-18.7	10.5		43355
21	40.80	16.31	0.026	-5.07E-03	-4.9	6.6		43355
22	40.28	4.65	0.029	-5.10E-03	0.6	2.5		43355
23	39.75	-7.00	0.032	-5.11E-03	-0.0	-0.0		---

At elev. 48.40 Strut force = 114.1 kN/strut = 114.1 kN/m run

At elev. 43.85 Strut force = 377.8 kN/strut = 377.8 kN/m run

(continued)

Stage No.16 Change properties of soil type 3 to soil type 4
 Ko pressures will not be reset

Node no.	Y coord	LEFT side					Total earth pressure kN/m2	Coeff. of subgrade reaction kN/m3
		Effective stresses						
		Water press. kN/m2	Vertic -al kN/m2	Active limit kN/m2	Passive limit kN/m2	Earth pressure kN/m2		
1	49.75	0.00	0.00	0.00	0.00	0.00	7239	
2	49.50	0.00	4.99	2.04	13.28	2.04	7239	
3	49.40	0.00	7.38	3.03	19.66	9.16	7239	
4	48.90	4.90	17.69	7.26	47.13	30.24	7239	
5	48.40	9.81	29.88	12.25	79.59	12.38	2754	
6	48.10	12.75	35.83	14.70	95.44	16.05	2754	
7	47.50	18.64	44.05	18.07	117.35	21.99	2754	
		18.64	44.05	17.43	122.82	28.72	7940	
8	47.15	22.07	47.68	18.86	132.92	34.29	7940	
9	46.80	25.51	50.68	20.05	141.30	39.30	7940	
10	46.20	31.39	55.08	21.79	153.57	46.30	7940	
11	45.60	37.28	59.09	23.38	164.73	50.29	7940	
12	45.00	43.16	63.00	24.92	175.63	49.50	7940	
		43.16	63.00	26.78	160.48	26.78	8152	
13	44.42	48.80	67.36	28.64	171.59	28.64	8621	
14	43.85	54.45	71.81	30.53	182.92	30.53	10994	
15	43.65	56.41	73.38	31.19	186.93	31.19	11191	
16	43.17	61.12	77.21	32.82	196.68	32.82	11665	
17	43.00	62.78	78.58	33.41	200.19	33.41	11832	
18	42.50	67.69	82.69	35.15	210.64	35.15	12325	
19	42.00	72.59	86.87	36.93	221.30	36.93	12818	
20	41.40	78.48	92.00	39.11	234.35	39.11	13410	
21	40.80	84.37	97.22	41.33	247.66	41.33	14002	
22	40.28	89.52	101.87	43.31	259.51	43.31	14519	
23	39.75	94.67	106.58	45.31	271.51	45.31	15037	

Node no.	Y coord	RIGHT side					Total earth pressure kN/m2	Coeff. of subgrade reaction kN/m3
		Effective stresses						
		Water press. kN/m2	Vertic -al kN/m2	Active limit kN/m2	Passive limit kN/m2	Earth pressure kN/m2		
1	49.75	0.00	0.00	0.00	0.00	0.00	0.0	
2	49.50	0.00	0.00	0.00	0.00	0.00	0.0	
3	49.40	0.00	0.00	0.00	0.00	0.00	0.0	
4	48.90	0.00	0.00	0.00	0.00	0.00	0.0	
5	48.40	0.00	0.00	0.00	0.00	0.00	0.0	
6	48.10	0.00	0.00	0.00	0.00	0.00	0.0	
7	47.50	0.00	0.00	0.00	0.00	0.00	0.0	
8	47.15	0.00	0.00	0.00	0.00	0.00	0.0	
9	46.80	0.00	0.00	0.00	0.00	0.00	0.0	
10	46.20	0.00	0.00	0.00	0.00	0.00	0.0	
11	45.60	0.00	0.00	0.00	0.00	0.00	0.0	
12	45.00	0.00	0.00	0.00	0.00	0.00	0.0	
13	44.42	0.00	0.00	0.00	0.00	0.00	0.0	
14	43.85	0.00	0.00	0.00	0.00	0.00	0.0	
15	43.65	0.00	0.00	0.00	0.00	0.00	0.0	
		0.00	0.00	0.00	0.00	0.00	3326	
16	43.17	0.00	8.64	3.54	23.02	20.37	3326	
		0.00	8.64	3.67	22.01	22.01	11665	
17	43.00	0.00	12.04	5.12	30.67	30.67	11832	
18	42.50	4.90	17.14	7.28	43.65	43.65	12325	
19	42.00	9.81	22.23	9.45	56.63	56.63	12818	
20	41.40	15.70	28.35	12.05	72.22	72.22	13410	

(continued)

Stage No.16 Change properties of soil type 3 to soil type 4
 Ko pressures will not be reset

Node no.	Y coord	----- RIGHT side -----					Total earth pressure	Coeff. of subgrade reaction
		Water press.	Vertic -al	Effective Active limit	Effective Passive limit	Earth pressure		
		kN/m2	kN/m2	kN/m2	kN/m2	kN/m2	kN/m2	kN/m3
21	40.80	21.58	34.47	14.65	87.80	87.80	109.38p	14002
22	40.28	26.73	39.82	16.93	101.44	101.44	128.18p	14519
23	39.75	31.88	45.18	19.21	115.09	115.09	146.98p	15037

Note: 139.98a Soil pressure at active limit
 146.98p Soil pressure at passive limit

Units: kN,m

Stage No.16 Change soil type 3 to soil type 4

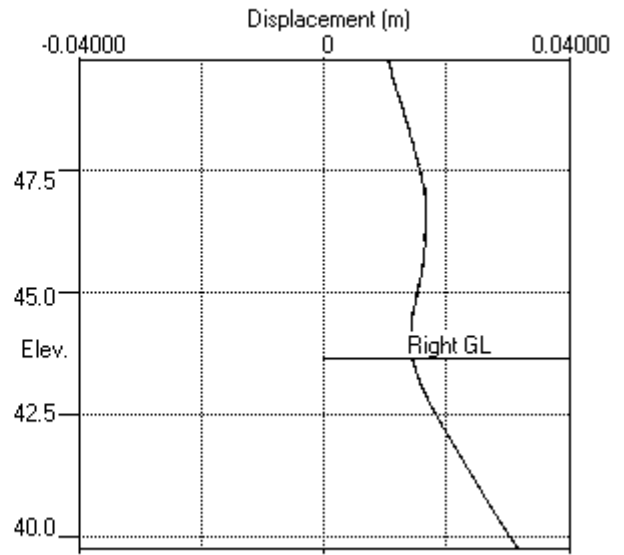
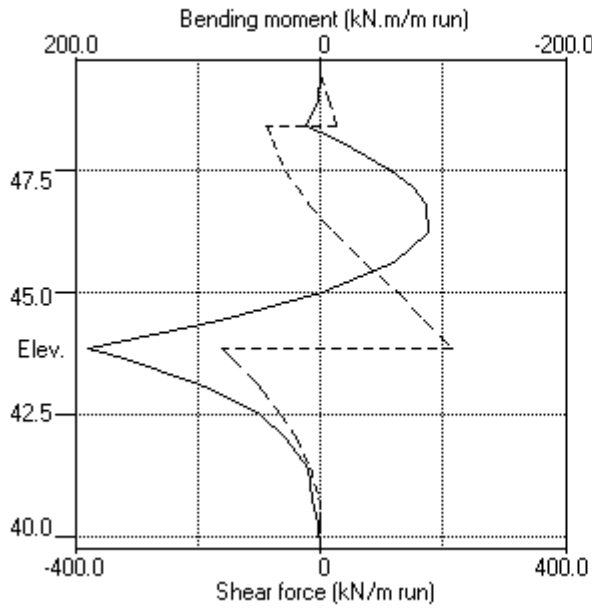

Stage No.16 Change soil type 3 to soil type 4

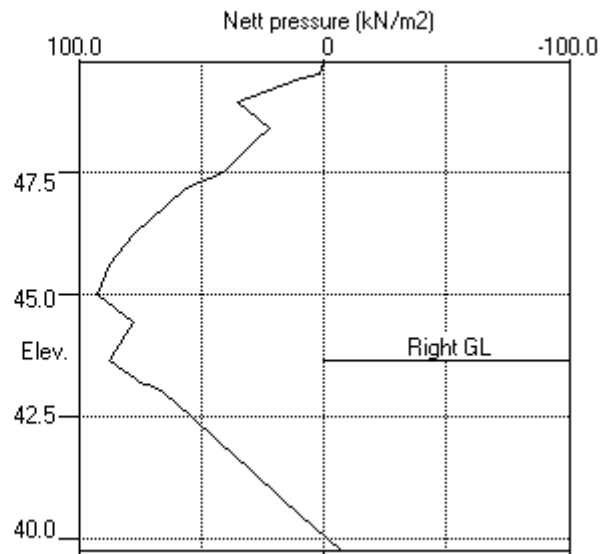
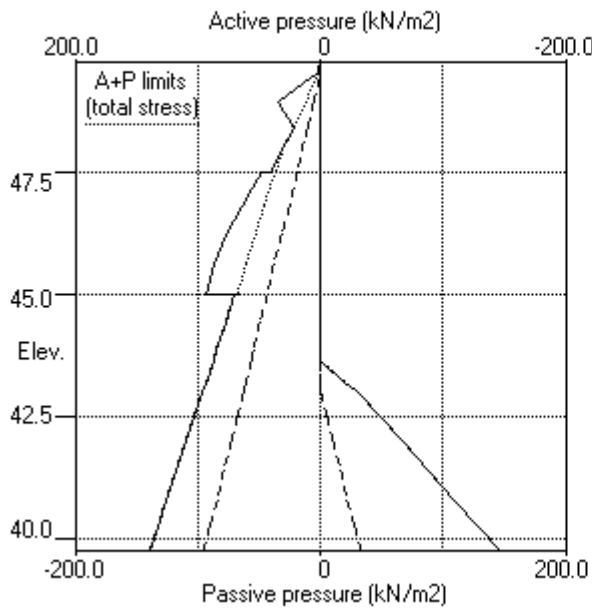

PILEDESIGNS LTD
 Program: WALLAP Version 6.06 Revision A51.B69.R54
 Licensed from GEOSOLVE
 Data filename/Run ID: Hampstead_Wall_6_450mm_rev_02_ULS2
 Hampstead - 24-26 Redington Gardens
 Wall 6, Secant-ULS2, 450 dia @ 650 - run 02

Sheet No.
 Job No. 21495
 Made by : DBS
 Date: 30-11-2018
 Checked :

Units: kN,m

Summary of results

LIMIT STATE PARAMETERS

Limit State: ULS DA1 Combination 2
 Water pressures : Worst Credible
 Partial factor on C' = 1.250
 Partial factor on Phi' = 1.250
 Partial factor on Cu = 1.400
 Partial factor on Soil Modulus = 1.000
 Partial factor on Permanent Unfavourable loads = 1.000
 Partial factor on Permanent Favourable loads = 1.000
 Partial factor on Variable Unfavourable loads = 1.300

STABILITY ANALYSIS of Fully Embedded Wall according to Strength Factor method

Factor of safety on soil strength

				Overall				
				FoS for toe	Toe elev. for			
				elev. = 39.75	FoS = 1.000			

Stage No.	--- G.L. Act.	--- Pass.	Strut Elev.	Factor of Safety	Moment at elev.	Toe elev.	Wall Penetr-ation	Direction of failure
1	49.75	49.75	Cant.	Conditions not suitable for FoS calc.				
2	49.75	49.75		No analysis at this stage				
3	49.75	49.75		No analysis at this stage				
4	49.75	49.75		No analysis at this stage				
5	49.75	49.75		No analysis at this stage				
6	49.75	49.75		No analysis at this stage				
7	49.75	49.75		No analysis at this stage				
8	49.75	49.75	Cant.	Conditions not suitable for FoS calc.				
9	49.75	48.10	Cant.	1.862	40.92	43.57	4.53	L to R
10	49.75	48.10		No analysis at this stage				
11	49.75	48.10	48.40	4.816	n/a	47.09	1.01	L to R
12	49.75	43.17	48.40	1.417	n/a	42.01	1.16	L to R
13	49.75	43.65	48.40	1.490	n/a	42.16	1.49	L to R
14	49.75	43.65		No analysis at this stage				

All remaining stages have more than one strut - FoS calculation n/a

PILEDESIGNS LTD
 Program: WALLAP Version 6.06 Revision A51.B69.R54
 Licensed from GEOSOLVE
 Data filename/Run ID: Hampstead_Wall_6_450mm_rev_02_ULS2
 Hampstead - 24-26 Redington Gardens
 Wall 6, Secant-ULS2, 450 dia @ 650 - run 02

Sheet No.
 Job No. 21495
 Made by : DBS
 Date: 30-11-2018
 Checked :

Units: kN,m

Summary of results

BENDING MOMENT and DISPLACEMENT ANALYSIS of Fully Embedded Wall

Analysis options

Length of wall perpendicular to section = 50.00m
 Subgrade reaction model - Boussinesq Influence coefficients
 Soil deformations are elastic until the active or passive limit is reached
 Open Tension Crack analysis - No

Rigid boundaries: Left side 50.00 from wall
 Right side 50.00 from wall

Limit State: ULS DA1 Combination 2

Bending moment, shear force and displacement envelopes

Node no.	Y coord	Displacement		Bending moment		Shear force	
		maximum m	minimum m	maximum kN.m/m	minimum kN.m/m	maximum kN/m	minimum kN/m
1	49.75	0.019	0.000	0.0	-0.0	0.0	0.0
2	49.50	0.018	0.000	0.2	-0.0	1.7	-0.9
3	49.40	0.018	0.000	0.4	-0.1	3.3	-1.6
4	48.90	0.015	0.000	4.3	-1.6	18.3	-3.8
5	48.40	0.014	0.000	18.8	-3.5	33.9	-109.8
6	48.10	0.015	0.000	10.1	-13.7	20.3	-102.3
7	47.50	0.017	0.000	26.0	-69.6	30.9	-83.1
8	47.15	0.018	0.000	37.0	-96.3	31.7	-69.6
9	46.80	0.019	0.000	47.8	-118.1	29.8	-54.4
10	46.20	0.020	0.000	62.9	-142.3	22.7	-24.7
11	45.60	0.020	0.000	71.4	-145.8	72.3	0.0
12	45.00	0.018	0.000	69.0	-128.5	126.4	-11.2
13	44.42	0.016	0.000	81.4	-98.0	168.7	-25.1
14	43.85	0.014	0.000	189.9	-57.8	215.4	-162.4
15	43.65	0.014	0.000	160.3	-41.1	86.8	-145.2
16	43.17	0.016	0.000	107.6	0.0	102.4	-106.5
17	43.00	0.016	0.000	95.7	0.0	90.2	-94.8
18	42.50	0.018	0.000	65.3	0.0	51.2	-64.8
19	42.00	0.020	0.000	74.9	0.0	11.4	-42.4
20	41.40	0.023	0.000	67.1	0.0	0.0	-29.7
21	40.80	0.026	0.000	44.7	-0.3	0.0	-50.5
22	40.28	0.029	0.000	16.4	-0.2	0.6	-42.5
23	39.75	0.032	0.000	0.0	-0.0	0.0	-0.0

Summary of results (continued)

Maximum and minimum bending moment and shear force at each stage

Stage no.	Bending moment				Shear force			
	maximum kN.m/m	elev.	minimum kN.m/m	elev.	maximum kN/m	elev.	minimum kN/m	elev.
1	0.4	43.85	-0.3	47.15	0.4	45.00	-0.2	48.90
2	No calculation at this stage							
3	No calculation at this stage							
4	No calculation at this stage							
5	No calculation at this stage							
6	No calculation at this stage							
7	No calculation at this stage							
8	7.3	43.85	-4.2	48.10	6.2	45.00	-3.8	48.90
9	71.4	45.60	-0.3	40.80	31.7	47.15	-27.4	43.85
10	No calculation at this stage							
11	64.3	45.00	-0.1	40.28	26.6	47.15	-24.8	43.85
12	73.4	42.00	-144.8	45.60	100.4	43.17	-109.3	48.40
13	74.9	42.00	-145.8	45.60	102.4	43.17	-109.8	48.40
14	No calculation at this stage							
15	67.6	42.00	-130.0	45.60	85.9	43.85	-102.7	48.40
16	189.9	43.85	-88.0	46.20	215.4	43.85	-162.4	43.85
17	No calculation at this stage							
18	164.6	43.85	-93.6	46.20	206.2	43.85	-110.2	43.85

Maximum and minimum displacement at each stage

Stage no.	Displacement				Stage description
	maximum m	elev.	minimum m	elev.	
1	0.000	49.75	0.000	49.75	Apply surcharge no.1 at elev. 49.75
2	No calculation at this stage				Apply surcharge no.2 at elev. 49.50
3	No calculation at this stage				Apply surcharge no.3 at elev. 49.75
4	Wall displacements reset to zero				Change EI of wall to 60696kN.m ² /m run
5	No calculation at this stage				Apply surcharge no.4 at elev. 49.75
6	No calculation at this stage				Apply surcharge no.5 at elev. 49.50
7	No calculation at this stage				Apply surcharge no.6 at elev. 49.75
8	0.003	49.75	0.000	49.75	Apply water pressure profile no.1
9	0.019	49.75	0.000	49.75	Excav. to elev. 48.10 on RIGHT side
10	No calculation at this stage				Install strut no.1 at elev. 48.40
11	0.019	49.75	0.000	49.75	Apply water pressure profile no.2
12	0.019	46.20	0.000	49.75	Excav. to elev. 43.17 on RIGHT side
13	0.019	46.20	0.000	49.75	Fill to elev. 43.65 on RIGHT side
14	No calculation at this stage				Install strut no.2 at elev. 43.85
15	0.020	46.20	0.000	49.75	Change EI of wall to 43355kN.m ² /m run
16	0.032	39.75	0.000	49.75	Change soil type 3 to soil type 4
17	No calculation at this stage				Apply surcharge no.7 at elev. 43.65
18	0.030	39.75	0.000	49.75	Apply water pressure profile no.3

Run ID. Hampstead_Wall_6_450mm_rev_02_ULS2
Hampstead - 24-26 Redington Gardens
Wall 6, Secant-ULS2, 450 dia @ 650 - run 02

| Sheet No.
| Date:30-11-2018
| Checked :

Summary of results (continued)

Strut forces at each stage (horizontal components)

Stage no.	--- Strut no. 1 --- at elev. 48.40		--- Strut no. 2 --- at elev. 43.85	
	kN/m run	kN/strut	kN/m run	kN/strut
11	6.34	6.34	---	---
12	142.06	142.06	---	---
13	142.45	142.45	---	---
15	136.60	136.60	33.43	33.43
16	114.11	114.11	377.84	377.84
18	117.16	117.16	316.46	316.46

Units: kN,m

Bending moment, shear force, displacement envelopes

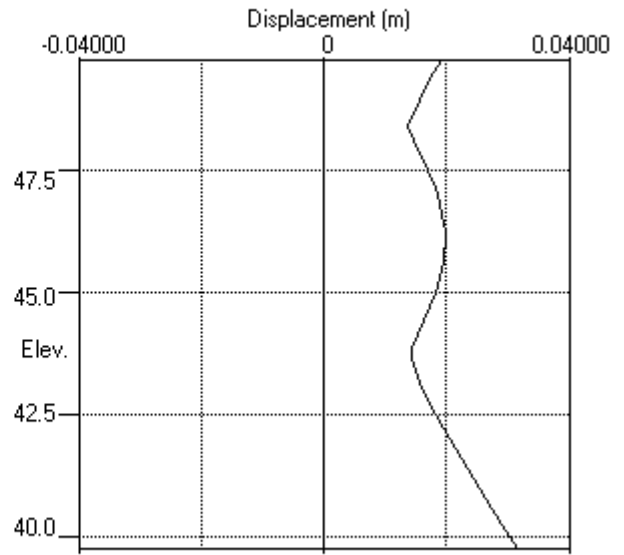
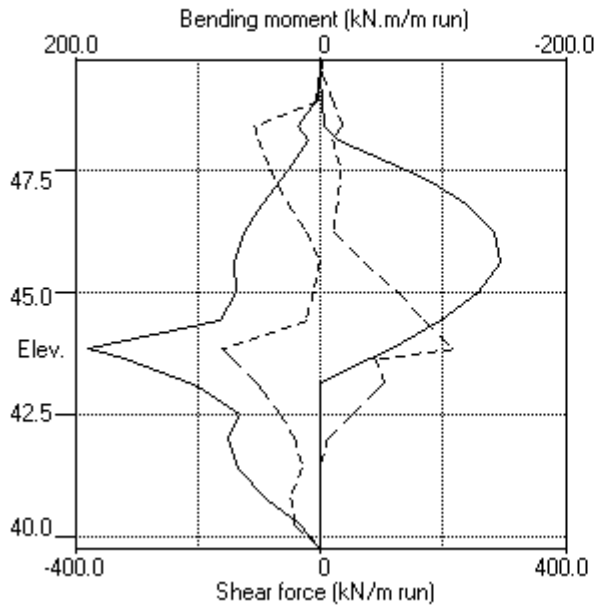



WALLAP

6-SLS

PILEDESIGNS LTD
 Program: WALLAP Version 6.06 Revision A51.B69.R54
 Licensed from GEOSOLVE
 Data filename/Run ID: Hampstead_Wall_6_450mm_rev_02_SLS
 Hampstead - 24-26 Redington Gardens
 Wall 6, Secant-SLS, 450 dia @ 650 - run 02

Sheet No.
 Job No. 21495
 Made by : DBS
 Date:30-11-2018
 Checked :

Units: kN,m

INPUT DATA

SOIL PROFILE

Stratum no.	Elevation of top of stratum	Soil types	
		Left side	Right side
1	49.75	1 Made Ground dr	1 Made Ground dr
2	47.50	2 Claygate Clay dr	2 Claygate Clay dr
3	45.00	3 London Clay und	3 London Clay und

SOIL PROPERTIES

No. Description (Datum elev.)	Bulk density kN/m3	Young's Modulus Eh,kN/m2 (dEh/dy)	At rest coeff. Ko (dKo/dy)	Consol state. NC/OC (Nu)	Active limit Ka (Kac)	Passive limit Kp (Kpc)	Cohesion kN/m2 (dc/dy)
1 Made Ground dr	18.00	10000	0.530	OC (0.250)	0.337 (0.000)	3.442 (0.000)	
2 Claygate Clay dr	19.00	30000	1.000	NC (0.200)	0.323 (1.330)	3.647 (5.195)	0.0d
3 London Cl.. (45.00)	20.00	40000 (4000)	1.000	OC (0.490)	1.000 (2.476)	1.000 (2.390)	50.00u (5.000)
4 London Cl.. (45.00)	20.00	30800 (3080)	1.000	OC (0.200)	0.351 (1.391)	3.253 (4.831)	0.0d

Additional soil parameters associated with Ka and Kp

No. Description	--- parameters for Ka ---			--- parameters for Kp ---		
	Soil friction angle	Wall adhesion coeff.	Back-fill angle	Soil friction angle	Wall adhesion coeff.	Back-fill angle
1 Made Ground dr	26.00	0.670	0.00	26.00	0.500	0.00
2 Claygate Clay dr	27.00	0.670	0.00	27.00	0.500	0.00
3 London Clay und	0.00	0.670	0.00	0.00	0.500	0.00
4 London Clay dr	25.00	0.670	0.00	25.00	0.500	0.00

GROUND WATER CONDITIONS

Density of water = 9.810 kN/m3

	Left side	Right side
Initial water table elevation	49.40	49.40

Automatic water pressure balancing at toe of wall : No

Water profile no.	Left side				Right side			
	Point no.	Elev. m	Piezo elev. m	Water press. kN/m2	Point no.	Elev. m	Piezo elev. m	Water press. kN/m2
1	1	49.40	49.40	0.0	1	47.50	47.50	0.0 MC+WC
2	1	49.40	49.40	0.0	1	43.00	43.00	0.0 MC+WC
3	1	49.40	49.40	0.0	1	43.65	43.65	0.0 MC+WC
					2	43.65	49.40	56.4

WALL PROPERTIES

Type of structure = Fully Embedded Wall
 Elevation of toe of wall = 40.75
 Maximum finite element length = 0.50 m
 Youngs modulus of wall E = 1.9600E+07 kN/m2
 Moment of inertia of wall I = 3.0968E-03 m4/m run
 E.I = 60696 kN.m2/m run
 Yield Moment of wall = Not defined

STRUTS and ANCHORS

Strut/ anchor no.	Elev.	Strut spacing m	X-section area of strut sq.m	Youngs modulus kN/m2	Free length m	Inclin -ation (degs)	Pre- stress /strut kN	Tension allowed
1	48.40	1.00	0.300000	1.400E+07	5.00	0.00	0	No
2	43.85	1.00	0.300000	1.400E+07	5.00	0.00	0	No

SURCHARGE LOADS

Surch -arge no.	Elev.	Distance from wall	Length parallel to wall	Width perpend. to wall	Surcharge ----- kN/m2 ----- Near edge Far edge		Equiv. soil type	Partial factor/ Category
1	49.75	0.50(L)	10.00	0.60	6.50	=	N/A	1.00 P/U
2	49.50	1.10(L)	10.00	0.50	50.00	=	N/A	1.00 P/U
3	49.75	1.60(L)	10.00	5.00	6.50	=	N/A	1.00 P/U
4	49.75	0.50(L)	10.00	0.60	5.00	=	N/A	1.00 Var
5	49.50	1.10(L)	10.00	0.50	40.00	=	N/A	1.00 Var
6	49.75	1.60(L)	10.00	5.00	5.00	=	N/A	1.00 Var
7	43.65	-0.00(R)	10.00	10.00	57.00	=	N/A	1.00 P/F

Note: L = Left side, R = Right side

Limit State Categories P/U = Permanent Unfavourable

P/F = Permanent Favourable

Var = Variable (unfavourable)

CONSTRUCTION STAGES

Construction stage no.	Stage description -----
1	Apply surcharge no.1 at elevation 49.75
2	Apply surcharge no.2 at elevation 49.50 No analysis at this stage
3	Apply surcharge no.3 at elevation 49.75 No analysis at this stage
4	Change EI of wall to 60696 kN.m2/m run Yield moment not defined Reset wall displacements to zero at this stage
5	Apply surcharge no.4 at elevation 49.75 No analysis at this stage
6	Apply surcharge no.5 at elevation 49.50 No analysis at this stage
7	Apply surcharge no.6 at elevation 49.75 No analysis at this stage
8	Apply water pressure profile no.1 (Mod. Conserv.)
9	Excavate to elevation 48.10 on RIGHT side
10	Install strut or anchor no.1 at elevation 48.40
11	Apply water pressure profile no.2 (Mod. Conserv.)
12	Excavate to elevation 43.65 on RIGHT side
13	Install strut or anchor no.2 at elevation 43.85
14	Change EI of wall to 43355 kN.m2/m run Yield moment not defined Allow wall to relax with new modulus value
15	Change properties of soil type 3 to soil type 4 Ko pressures will not be reset
16	Apply surcharge no.7 at elevation 43.65 No analysis at this stage
17	Apply water pressure profile no.3 (Mod. Conserv.)

FACTORS OF SAFETY and ANALYSIS OPTIONS

Limit State options: Serviceability Limit State
All loads and soil strengths are unfactored

Stability analysis:

Method of analysis - Strength Factor method
Factor on soil strength for calculating wall depth = 1.50

Parameters for undrained strata:

Minimum equivalent fluid density = 5.00 kN/m³
Maximum depth of water filled tension crack = 0.00 m

Bending moment and displacement calculation:

Method - Subgrade reaction model using Influence Coefficients
Open Tension Crack analysis? - No
Non-linear Modulus Parameter (L) = 9.000 m

Boundary conditions:

Length of wall (normal to plane of analysis) = 50.00 m

Width of excavation on Left side of wall = 50.00 m
Width of excavation on Right side of wall = 50.00 m

Distance to rigid boundary on Left side = 50.00 m
Distance to rigid boundary on Right side = 50.00 m

OUTPUT OPTIONS

Stage no.	Stage description	Displacement	Active, Passive	Graph. output
		Bending mom.	pressures	
		Shear force		
1	Apply surcharge no.1 at elev. 49.75	No	No	No
2	Apply surcharge no.2 at elev. 49.50	Yes	Yes	Yes
3	Apply surcharge no.3 at elev. 49.75	Yes	Yes	Yes
4	Change EI of wall to 60696kN.m ² /m run	Yes	Yes	Yes
5	Apply surcharge no.4 at elev. 49.75	Yes	Yes	Yes
6	Apply surcharge no.5 at elev. 49.50	Yes	Yes	Yes
7	Apply surcharge no.6 at elev. 49.75	Yes	Yes	Yes
8	Apply water pressure profile no.1	Yes	Yes	Yes
9	Excav. to elev. 48.10 on RIGHT side	Yes	Yes	Yes
10	Install strut no.1 at elev. 48.40	Yes	Yes	Yes
11	Apply water pressure profile no.2	Yes	Yes	Yes
12	Excav. to elev. 43.65 on RIGHT side	Yes	Yes	Yes
13	Install strut no.2 at elev. 43.85	Yes	Yes	Yes
14	Change EI of wall to 43355kN.m ² /m run	No	No	No
15	Change soil type 3 to soil type 4	No	No	No
16	Apply surcharge no.7 at elev. 43.65	No	No	No
17	Apply water pressure profile no.3	No	No	No
*	Summary output	Yes	-	Yes

Program WALLAP - Copyright (C) 2017 by DL Borin, distributed by GEOSOLVE
150 St. Alphonsus Road, London SW4 7BW, UK www.geosolve.co.uk

Units: kN,m

Stage No.17 Apply water pressure profile no.3 (Mod. Conserv.)

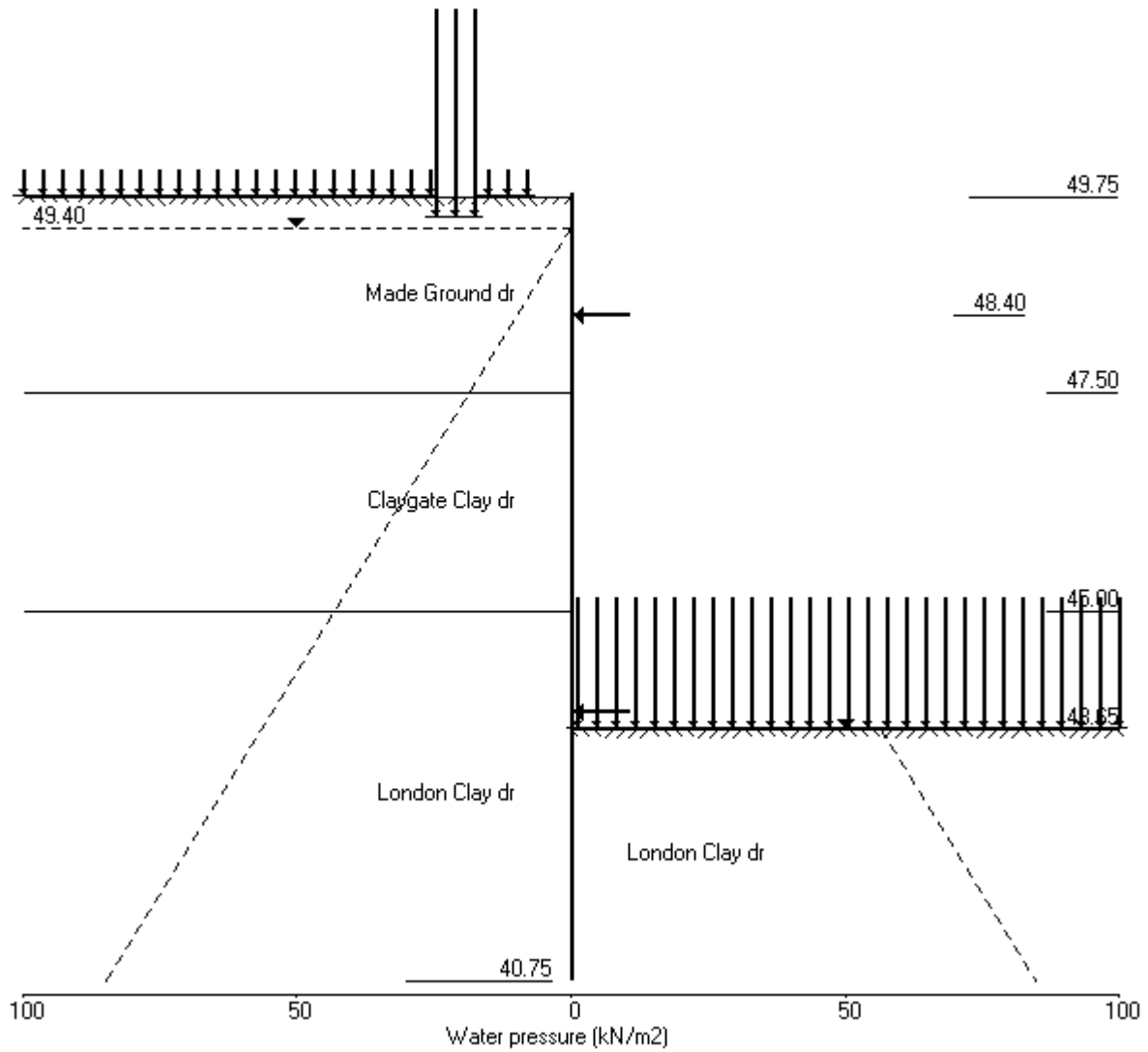

PILEDESIGNS LTD
 Program: WALLAP Version 6.06 Revision A51.B69.R54
 Licensed from GEOSOLVE
 Data filename/Run ID: Hampstead_Wall_6_450mm_rev_02_SLS
 Hampstead - 24-26 Redington Gardens
 Wall 6, Secant-SLS, 450 dia @ 650 - run 02

Sheet No.
 Job No. 21495
 Made by : DBS
 Date:30-11-2018
 Checked :

Units: kN,m

Stage No. 9 Excavate to elevation 48.10 on RIGHT side

STABILITY ANALYSIS of Fully Embedded Wall according to Strength Factor method
 Factor of safety on soil strength

Stage No.	--- G.L. --- Act.	--- G.L. --- Pass.	Strut Elev.	FoS for toe elev. =	Moment of equil. at elev.	Toe elev. for FoS =	Wall Penetr-ation	Direction of failure
9	49.75	48.10	Cant.	40.75	41.82	1.500	5.30	L to R

BENDING MOMENT and DISPLACEMENT ANALYSIS of Fully Embedded Wall

Analysis options

Length of wall perpendicular to section = 50.00m
 Subgrade reaction model - Boussinesq Influence coefficients
 Soil deformations are elastic until the active or passive limit is reached
 Open Tension Crack analysis - No

Rigid boundaries: Left side 50.00 from wall
 Right side 50.00 from wall

Limit State: Serviceability Limit State

Calculated Bending Moments and Strut Forces are to be multiplied by a factor of 1.35 to obtain values for structural design. See summary for factored values.

*** Wall displacements reset to zero at stage 4

Node no.	Y coord	Nett pressure kN/m2	Wall disp. m	Wall rotation rad.	Shear force kN/m	Bending moment kN.m/m	Strut forces kN/m	EI of wall kN.m2/m
1	49.75	0.00	0.009	2.19E-03	0.0	0.0		60696
2	49.50	1.66	0.009	2.19E-03	0.2	0.1		60696
3	49.40	2.44	0.009	2.19E-03	0.4	0.1		60696
4	48.90	10.58	0.007	2.18E-03	3.7	0.9		60696
5	48.40	19.26	0.006	2.16E-03	11.1	4.5		60696
6	48.10	24.07	0.006	2.12E-03	17.6	8.7		60696
7	47.80	9.90	0.005	2.06E-03	22.7	14.9		60696
8	47.50	6.07	0.004	1.97E-03	25.1	22.3		60696
		-7.37	0.004	1.97E-03	25.1	22.3		
9	47.00	-22.54	0.004	1.74E-03	17.6	33.2		60696
10	46.50	-29.09	0.003	1.43E-03	4.7	40.4		60696
11	46.00	-15.61	0.002	1.11E-03	-6.4	39.1		60696
12	45.50	-6.31	0.002	8.09E-04	-11.9	33.8		60696
13	45.00	-0.51	0.001	5.59E-04	-13.6	27.0		60696
		-2.80	0.001	5.59E-04	-13.6	27.0		
14	44.50	2.72	0.001	3.69E-04	-13.6	19.8		60696
15	44.17	4.65	0.001	2.76E-04	-12.4	15.5		60696
16	43.85	5.59	0.001	2.05E-04	-10.8	11.7		60696
17	43.65	5.79	0.001	1.71E-04	-9.6	9.7		60696
18	43.33	5.69	0.001	1.29E-04	-7.8	6.8		60696
19	43.00	5.22	0.001	1.00E-04	-6.0	4.6		60696
20	42.50	4.11	0.001	7.48E-05	-3.7	2.2		60696
21	42.00	2.89	0.001	6.37E-05	-1.9	0.8		60696
22	41.50	1.76	0.001	6.01E-05	-0.8	0.2		60696
23	41.13	1.00	0.001	5.95E-05	-0.2	0.0		60696
24	40.75	0.32	0.001	5.95E-05	0.0	-0.0		---

(continued)

Stage No.9 Excavate to elevation 48.10 on RIGHT side

Node no.	Y coord	LEFT side					Total earth pressure kN/m2	Coeff. of subgrade reaction kN/m3
		Water press. kN/m2	Vertic -al kN/m2	Effective Active limit kN/m2	Effective Passive limit kN/m2	Earth pressure kN/m2		
1	49.75	0.00	0.00	0.00	0.00	0.00	0.00	3796
2	49.50	0.00	4.93	1.66	16.97	1.66	1.66a	3796
3	49.40	0.00	7.26	2.44	24.98	2.44	2.44a	3796
4	48.90	4.90	16.84	5.67	57.98	5.67	10.58a	3796
5	48.40	9.81	28.08	9.45	96.66	9.45	19.26a	3796
6	48.10	12.75	33.62	11.32	115.73	11.32	24.07a	3796
7	47.80	15.70	38.00	12.79	130.82	12.79	28.49a	3796
8	47.50	18.64	41.46	13.96	142.71	13.96	32.60a	3796
		18.64	41.46	13.37	151.20	13.37	32.01a	10960
9	47.00	23.54	46.39	14.96	169.16	14.96	38.51a	10960
10	46.50	28.45	50.40	16.26	183.81	24.78	53.23	10960
11	46.00	33.35	54.01	17.42	196.97	34.82	68.17	10960
12	45.50	38.26	57.46	18.54	209.56	42.96	81.22	10960
13	45.00	43.16	60.88	19.64	222.01	49.57	92.74	10960
		Total>	104.04	23.75m	223.54	81.21	81.21	21051
14	44.50	Total>	112.89	26.25m	238.36	93.20	93.20	22104
15	44.17	Total>	118.67	27.88m	248.02	100.28	100.28	22788
16	43.85	Total>	124.47	29.50m	257.71	106.93	106.93	23472
17	43.65	Total>	128.06	30.50m	263.69	110.87	110.87	23893
18	43.33	Total>	133.92	32.12m	273.43	117.08	117.08	24577
19	43.00	Total>	139.81	33.75m	283.21	123.14	123.14	25261
20	42.50	Total>	148.93	36.25m	298.30	132.30	132.30	26314
21	42.00	Total>	158.13	38.75m	313.48	141.44	141.44	27366
22	41.50	Total>	167.39	41.25m	328.71	150.64	150.64	28419
23	41.13	Total>	174.38	43.13m	340.19	157.61	157.61	29208
24	40.75	Total>	181.41	45.00m	351.69	164.63	164.63	29998

Node no.	Y coord	RIGHT side					Total earth pressure kN/m2	Coeff. of subgrade reaction kN/m3
		Water press. kN/m2	Vertic -al kN/m2	Effective Active limit kN/m2	Effective Passive limit kN/m2	Earth pressure kN/m2		
1	49.75	0.00	0.00	0.00	0.00	0.00	0.00	0.0
2	49.50	0.00	0.00	0.00	0.00	0.00	0.00	0.0
3	49.40	0.00	0.00	0.00	0.00	0.00	0.00	0.0
4	48.90	0.00	0.00	0.00	0.00	0.00	0.00	0.0
5	48.40	0.00	0.00	0.00	0.00	0.00	0.00	0.0
6	48.10	0.00	0.00	0.00	0.00	0.00	0.00	0.0
		0.00	0.00	0.00	0.00	0.00	0.00	5028
7	47.80	0.00	5.40	1.82	18.59	18.59	18.59p	5028
8	47.50	0.00	10.80	3.64	37.18	26.53	26.53	5028
		0.00	10.80	3.48	39.39	39.39	39.39p	14544
9	47.00	4.90	15.40	4.97	56.14	56.14	61.05p	14544
10	46.50	9.81	19.99	6.45	72.90	72.51	82.32	14544
11	46.00	14.71	24.59	7.93	89.66	69.06	83.78	14544
12	45.50	19.62	29.18	9.41	106.42	67.91	87.53	14544
13	45.00	24.52	33.78	10.90	123.18	68.73	93.25	14544
		Total>	58.30	15.50m	177.80	84.00	84.00	27447
14	44.50	Total>	68.30	18.00m	193.78	90.47	90.47	28819
15	44.17	Total>	74.81	19.62m	204.16	95.63	95.63	29711
16	43.85	Total>	81.31	21.25m	214.55	101.35	101.35	30603
17	43.65	Total>	85.31	22.25m	220.94	105.08	105.08	31152
18	43.33	Total>	91.81	23.87m	231.32	111.39	111.39	32044
19	43.00	Total>	98.31	25.50m	241.71	117.92	117.92	32936

(continued)

Stage No.9 Excavate to elevation 48.10 on RIGHT side

Node no.	Y coord	----- RIGHT side -----					Total earth pressure	Coeff. of subgrade reaction
		Water press. kN/m2	Vertic -al kN/m2	Effective Active limit kN/m2	Effective Passive limit kN/m2	Earth pressure kN/m2		
20	42.50	Total>	108.32	28.00m	257.69	128.19	128.19	34309
21	42.00	Total>	118.32	30.50m	273.67	138.55	138.55	35681
22	41.50	Total>	128.33	33.00m	289.65	148.89	148.89	37054
23	41.13	Total>	135.83	34.87m	301.64	156.61	156.61	38083
24	40.75	Total>	143.34	36.75m	313.62	164.31	164.31	39112

Note: 38.51a Soil pressure at active limit
 61.05p Soil pressure at passive limit

Units: kN,m

Stage No.9 Excav. to elev. 48.10 on RIGHT side

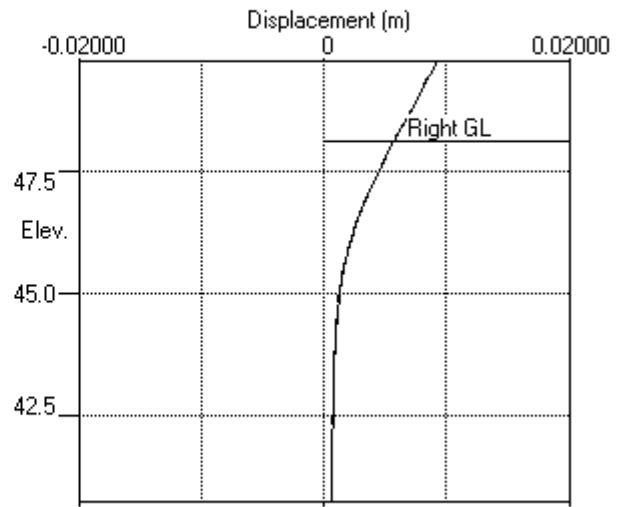
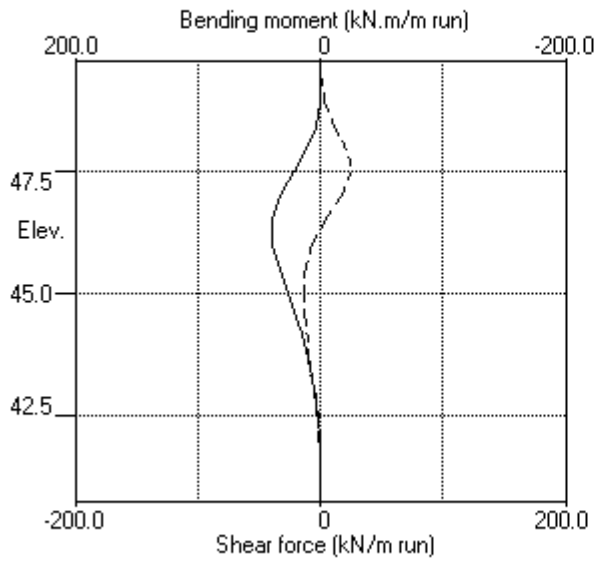

Stage No.9 Excav. to elev. 48.10 on RIGHT side

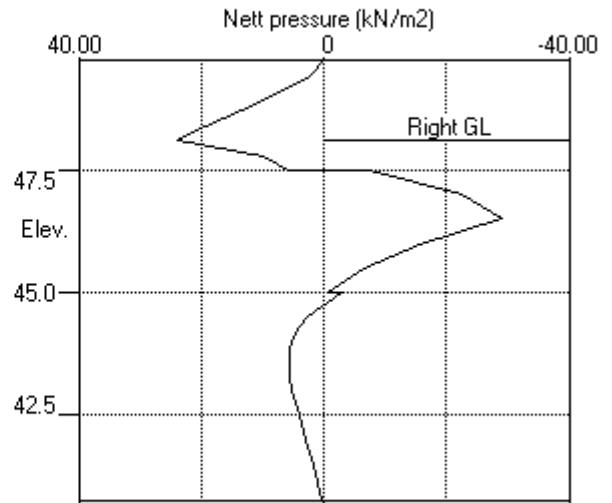
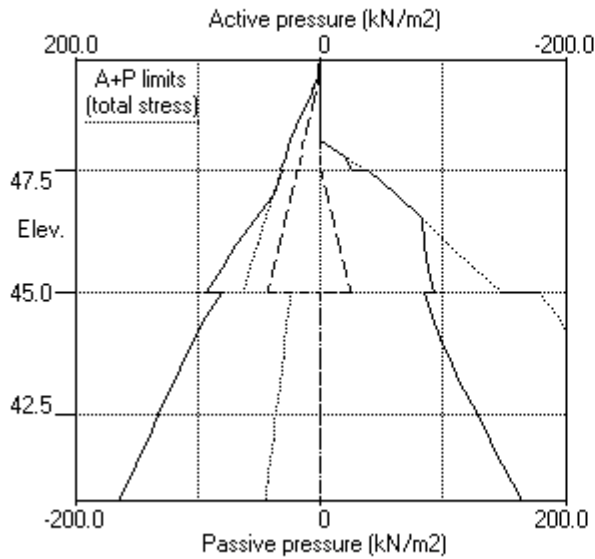

Units: kN,m

Stage No. 12 Excavate to elevation 43.65 on RIGHT side

STABILITY ANALYSIS of Fully Embedded Wall according to Strength Factor method
Factor of safety on soil strength

Stage No.	--- G.L. --- Act. Pass.	Strut Elev.	FoS for toe elev. = 40.75	Moment of equilib. at elev.	Toe elev. for FoS = 1.500	Wall Penetr- -ation	Direction of failure
12	49.75 43.65	48.40	1.969	n/a	42.37	1.28	L to R

BENDING MOMENT and DISPLACEMENT ANALYSIS of Fully Embedded Wall

Analysis options

Length of wall perpendicular to section = 50.00m

Subgrade reaction model - Boussinesq Influence coefficients

Soil deformations are elastic until the active or passive limit is reached

Open Tension Crack analysis - No

Rigid boundaries: Left side 50.00 from wall

Right side 50.00 from wall

Limit State: Serviceability Limit State

Calculated Bending Moments and Strut Forces are to be multiplied by a factor of 1.35 to obtain values for structural design. See summary for factored values.

*** Wall displacements reset to zero at stage 4

Node no.	Y coord	Nett pressure kN/m2	Wall disp. m	Wall rotation rad.	Shear force kN/m	Bending moment kN.m/m	Strut forces kN/m	EI of wall kN.m2/m
1	49.75	0.00	0.003	-2.31E-03	0.0	0.0		60696
2	49.50	16.97	0.004	-2.31E-03	2.1	0.2		60696
3	49.40	24.98	0.004	-2.31E-03	4.2	0.5		60696
4	48.90	26.67	0.005	-2.33E-03	17.1	5.2		60696
5	48.40	19.26	0.006	-2.43E-03	28.6	17.5	118.6	60696
		19.26	0.006	-2.43E-03	-90.0	17.5		
6	48.10	24.07	0.007	-2.45E-03	-83.5	-8.6		60696
7	47.80	28.49	0.008	-2.35E-03	-75.6	-32.5		60696
8	47.50	32.60	0.009	-2.14E-03	-66.5	-53.6		60696
		32.01	0.009	-2.14E-03	-66.5	-53.6		
9	47.00	38.51	0.010	-1.58E-03	-48.8	-82.6		60696
10	46.50	44.71	0.010	-8.30E-04	-28.0	-100.4		60696
11	46.00	50.78	0.010	3.11E-05	-4.2	-109.2		60696
12	45.50	56.80	0.010	9.13E-04	22.7	-105.1		60696
13	45.00	62.80	0.009	1.70E-03	52.6	-86.7		60696
		23.75	0.009	1.70E-03	52.6	-86.7		
14	44.50	26.25	0.008	2.30E-03	65.1	-57.7		60696
15	44.17	27.88	0.008	2.55E-03	73.9	-35.1		60696
16	43.85	29.50	0.007	2.67E-03	83.2	-9.7		60696
17	43.65	30.50	0.006	2.67E-03	89.2	7.6		60696
		-105.13	0.006	2.67E-03	89.2	7.6		
18	43.33	-102.99	0.005	2.57E-03	55.4	32.3		60696
19	43.00	-96.81	0.005	2.36E-03	23.0	44.8		60696
20	42.50	-55.29	0.004	1.98E-03	-15.1	49.2		60696
21	42.00	-16.78	0.003	1.64E-03	-33.1	34.7		60696
22	41.50	17.92	0.002	1.43E-03	-32.8	16.0		60696
23	41.13	43.30	0.001	1.36E-03	-21.3	5.0		60696
24	40.75	70.42	0.001	1.35E-03	0.0	0.0		---

At elev. 48.40 Strut force = 118.6 kN/strut = 118.6 kN/m run

(continued)

Stage No.12 Excavate to elevation 43.65 on RIGHT side

Node no.	Y coord	LEFT side					Total earth pressure kN/m2	Coeff. of subgrade reaction kN/m3
		Water press. kN/m2	Vertic -al kN/m2	Effective Active limit kN/m2	Effective Passive limit kN/m2	Earth pressure kN/m2		
1	49.75	0.00	0.00	0.00	0.00	0.00	0.00	7541
2	49.50	0.00	4.93	1.66	16.97	16.97	16.97p	7541
3	49.40	0.00	7.26	2.44	24.98	24.98	24.98p	7541
4	48.90	4.90	16.84	5.67	57.98	21.77	26.67	7541
5	48.40	9.81	28.08	9.45	96.66	9.45	19.26a	2350
6	48.10	12.75	33.62	11.32	115.73	11.32	24.07a	2350
7	47.80	15.70	38.00	12.79	130.82	12.79	28.49a	2350
8	47.50	18.64	41.46	13.96	142.71	13.96	32.60a	2350
		18.64	41.46	13.37	151.20	13.37	32.01a	6752
9	47.00	23.54	46.39	14.96	169.16	14.96	38.51a	6752
10	46.50	28.45	50.40	16.26	183.81	16.26	44.71a	6752
11	46.00	33.35	54.01	17.42	196.97	17.42	50.78a	6752
12	45.50	38.26	57.46	18.54	209.56	18.54	56.80a	6752
13	45.00	43.16	60.88	19.64	222.01	19.64	62.80a	6752
		Total>	104.04	23.75m	223.54	23.75	23.75a	13618
14	44.50	Total>	112.89	26.25m	238.36	26.25	26.25a	14299
15	44.17	Total>	118.67	27.88m	248.02	27.88	27.88a	14741
16	43.85	Total>	124.47	29.50m	257.71	29.50	29.50a	15184
17	43.65	Total>	128.06	30.50m	263.69	30.50	30.50a	15456
18	43.33	Total>	133.92	32.12m	273.43	43.02	43.02	15899
19	43.00	Total>	139.81	33.75m	283.21	59.59	59.59	16341
20	42.50	Total>	148.93	36.25m	298.30	83.96	83.96	17022
21	42.00	Total>	158.13	38.75m	313.48	106.54	106.54	17703
22	41.50	Total>	167.39	41.25m	328.71	127.86	127.86	18384
23	41.13	Total>	174.38	43.13m	340.19	143.66	143.66	18895
24	40.75	Total>	181.41	45.00m	351.69	160.23	160.23	19406

Node no.	Y coord	RIGHT side					Total earth pressure kN/m2	Coeff. of subgrade reaction kN/m3
		Water press. kN/m2	Vertic -al kN/m2	Effective Active limit kN/m2	Effective Passive limit kN/m2	Earth pressure kN/m2		
1	49.75	0.00	0.00	0.00	0.00	0.00	0.00	0.0
2	49.50	0.00	0.00	0.00	0.00	0.00	0.00	0.0
3	49.40	0.00	0.00	0.00	0.00	0.00	0.00	0.0
4	48.90	0.00	0.00	0.00	0.00	0.00	0.00	0.0
5	48.40	0.00	0.00	0.00	0.00	0.00	0.00	0.0
6	48.10	0.00	0.00	0.00	0.00	0.00	0.00	0.0
7	47.80	0.00	0.00	0.00	0.00	0.00	0.00	0.0
8	47.50	0.00	0.00	0.00	0.00	0.00	0.00	0.0
9	47.00	0.00	0.00	0.00	0.00	0.00	0.00	0.0
10	46.50	0.00	0.00	0.00	0.00	0.00	0.00	0.0
11	46.00	0.00	0.00	0.00	0.00	0.00	0.00	0.0
12	45.50	0.00	0.00	0.00	0.00	0.00	0.00	0.0
13	45.00	0.00	0.00	0.00	0.00	0.00	0.00	0.0
14	44.50	0.00	0.00	0.00	0.00	0.00	0.00	0.0
15	44.17	0.00	0.00	0.00	0.00	0.00	0.00	0.0
16	43.85	0.00	0.00	0.00	0.00	0.00	0.00	0.0
17	43.65	0.00	0.00	0.00	0.00	0.00	0.00	0.0
		Total>	0.00	0.00	135.63	135.63	135.63p	30702
18	43.33	Total>	6.50	1.63m	146.01	146.01	146.01p	31581
19	43.00	Total>	13.00	3.25m	156.40	156.40	156.40p	32460
20	42.50	Total>	23.00	5.75m	172.37	139.25	139.25	33812
21	42.00	Total>	33.00	8.25m	188.35	123.32	123.32	35165

(continued)

Stage No.12 Excavate to elevation 43.65 on RIGHT side

Node no.	Y coord	----- Effective stresses -----					Total earth pressure	Coeff. of subgrade reaction
		Water press. kN/m2	Vertic -al kN/m2	Active limit kN/m2	Passive limit kN/m2	Earth pressure kN/m2		
22	41.50	Total>	43.00	10.75m	204.33	109.94	109.94	36517
23	41.13	Total>	50.51	12.63m	216.31	100.36	100.36	37532
24	40.75	Total>	58.01	14.50m	228.29	89.81	89.81	38546

Note: 30.50a Soil pressure at active limit
 156.40p Soil pressure at passive limit

Units: kN,m

Stage No.12 Excav. to elev. 43.65 on RIGHT side

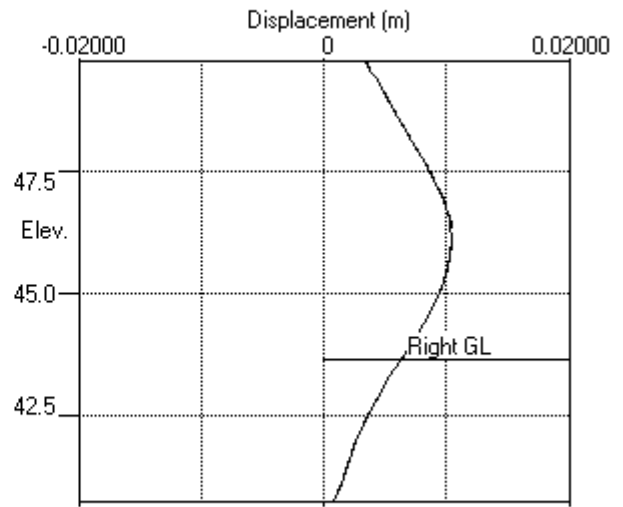
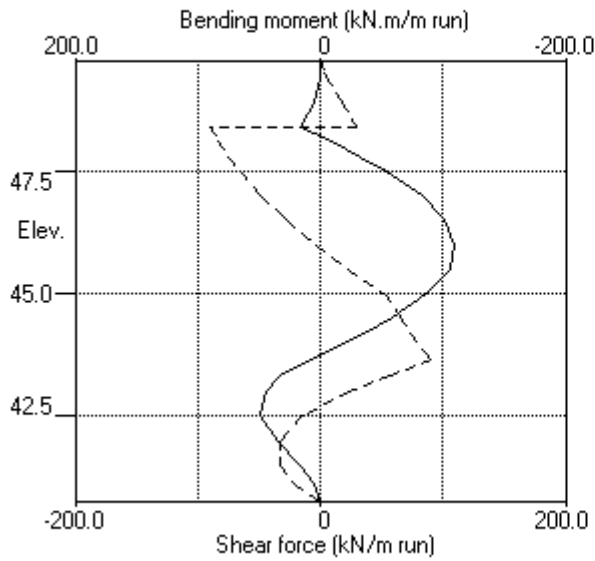

Stage No.12 Excav. to elev. 43.65 on RIGHT side

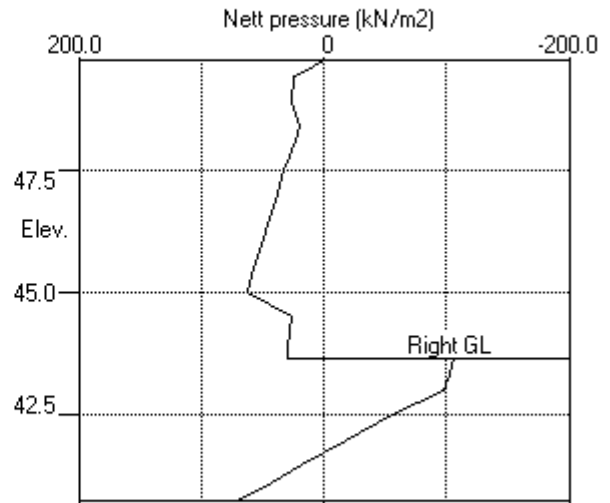
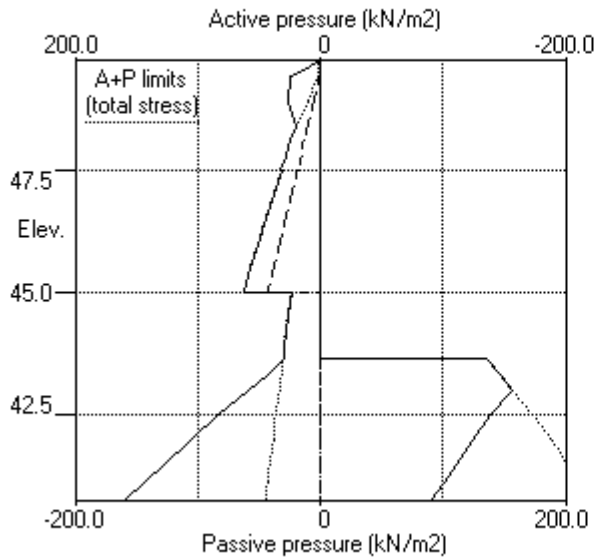

Units: kN,m

Stage No. 14 Change EI of wall to 43355 kN.m2/m run
 Yield moment not defined
 Allow wall to relax with new modulus value

STABILITY ANALYSIS of Fully Embedded Wall according to Strength Factor method
 Factor of safety on soil strength

			FoS for toe elev. = 40.75		Toe elev. for FoS = 1.500		
Stage No.	--- G.L. Act.	--- Pass.	Strut Elev.	Factor of Safety	Moment of equil. at elev.	Toe Wall Penetr-ation	Direction of failure
14	49.75	43.65				No FoS calc.	

BENDING MOMENT and DISPLACEMENT ANALYSIS of Fully Embedded Wall

Analysis options

Length of wall perpendicular to section = 50.00m
 Subgrade reaction model - Boussinesq Influence coefficients
 Soil deformations are elastic until the active or passive limit is reached
 Open Tension Crack analysis - No

Rigid boundaries: Left side 50.00 from wall
 Right side 50.00 from wall

Limit State: Serviceability Limit State

Calculated Bending Moments and Strut Forces are to be multiplied by a factor of 1.35 to obtain values for structural design. See summary for factored values.

*** Wall displacements reset to zero at stage 4

Node no.	Y coord	Nett pressure kN/m2	Wall disp. m	Wall rotation rad.	Shear force kN/m	Bending moment kN.m/m	Strut forces kN/m	EI of wall kN.m2/m
1	49.75	0.00	0.003	-2.87E-03	0.0	0.0		43355
2	49.50	16.97	0.003	-2.87E-03	2.1	0.2		43355
3	49.40	24.98	0.004	-2.87E-03	4.2	0.5		43355
4	48.90	28.86	0.005	-2.90E-03	17.7	5.2		43355
5	48.40	19.29	0.006	-3.04E-03	29.7	17.9	115.9	43355
		19.29	0.006	-3.04E-03	-86.2	17.9		
6	48.10	24.07	0.007	-3.08E-03	-79.7	-7.2		43355
7	47.80	28.49	0.008	-2.96E-03	-71.8	-30.2		43355
8	47.50	32.60	0.009	-2.68E-03	-62.6	-50.5		43355
		32.01	0.009	-2.68E-03	-62.6	-50.5		
9	47.00	38.51	0.010	-1.96E-03	-45.0	-78.0		43355
10	46.50	44.71	0.011	-9.89E-04	-24.2	-94.3		43355
11	46.00	50.78	0.011	1.15E-04	-0.3	-101.6		43355
12	45.50	56.80	0.011	1.22E-03	26.6	-96.0		43355
13	45.00	62.80	0.010	2.18E-03	56.5	-76.2		43355
		23.75	0.010	2.18E-03	56.5	-76.2		
14	44.50	26.25	0.009	2.85E-03	69.0	-45.7		43355
15	44.17	27.88	0.008	3.08E-03	77.8	-22.2		43355
16	43.85	29.50	0.007	3.12E-03	87.1	4.3	22.0	43355
		29.50	0.007	3.12E-03	65.1	4.3		
17	43.65	31.89	0.006	3.05E-03	71.2	18.7		43355
		-102.36	0.006	3.05E-03	71.2	18.7		
18	43.33	-95.01	0.005	2.82E-03	39.1	39.0		43355
19	43.00	-85.50	0.004	2.49E-03	9.8	47.7		43355
20	42.50	-42.57	0.003	1.93E-03	-22.2	48.0		43355
21	42.00	-6.49	0.002	1.48E-03	-34.5	32.0		43355

(continued)

Stage No.14 Change EI of wall to 43355 kN.m2/m run
 Yield moment not defined
 Allow wall to relax with new modulus value

Node no.	Y coord	RIGHT side						
		Water press. kN/m2	Vertic -al kN/m2	Effective Active limit kN/m2	Effective Passive limit kN/m2	Earth pressure kN/m2	Total earth pressure kN/m2	Coeff. of subgrade reaction kN/m3
12	45.50	0.00	0.00	0.00	0.00	0.00	0.00	0.0
13	45.00	0.00	0.00	0.00	0.00	0.00	0.00	0.0
14	44.50	0.00	0.00	0.00	0.00	0.00	0.00	0.0
15	44.17	0.00	0.00	0.00	0.00	0.00	0.00	0.0
16	43.85	0.00	0.00	0.00	0.00	0.00	0.00	0.0
17	43.65	0.00	0.00	0.00	0.00	0.00	0.00	0.0
		Total>	0.00	0.00	135.63	134.24	134.24	24259
18	43.33	Total>	6.50	1.63m	146.01	142.02	142.02	24953
19	43.00	Total>	13.00	3.25m	156.40	150.74	150.74	25648
20	42.50	Total>	23.00	5.75m	172.37	132.89	132.89	26717
21	42.00	Total>	33.00	8.25m	188.35	118.17	118.17	27785
22	41.50	Total>	43.00	10.75m	204.33	107.25	107.25	28854
23	41.13	Total>	50.51	12.63m	216.31	99.90	99.90	29655
24	40.75	Total>	58.01	14.50m	228.29	100.13	100.13	162097

Note: 29.50a Soil pressure at active limit
 24.98p Soil pressure at passive limit

Units: kN,m

Stage No.14 Change EI of wall to 43355kN.m²/m run

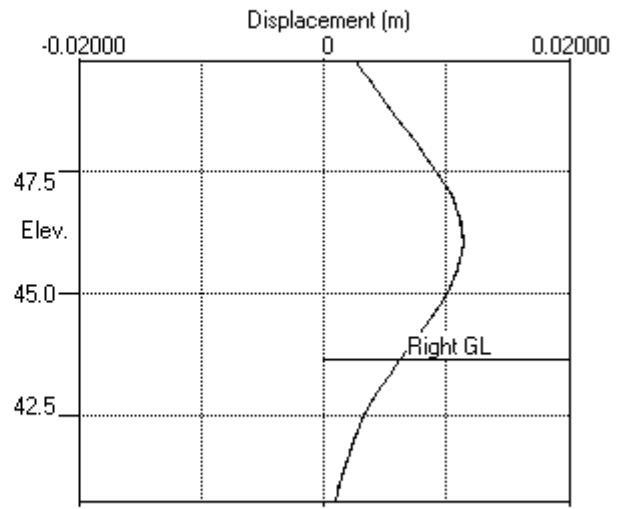
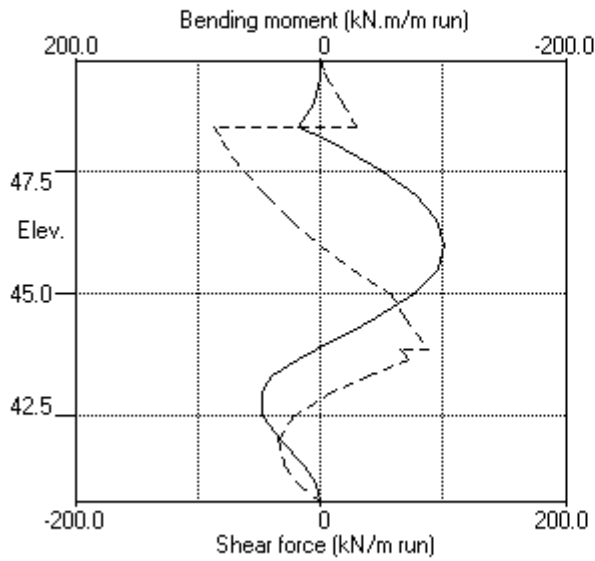

Stage No.14 Change EI of wall to 43355kN.m²/m run

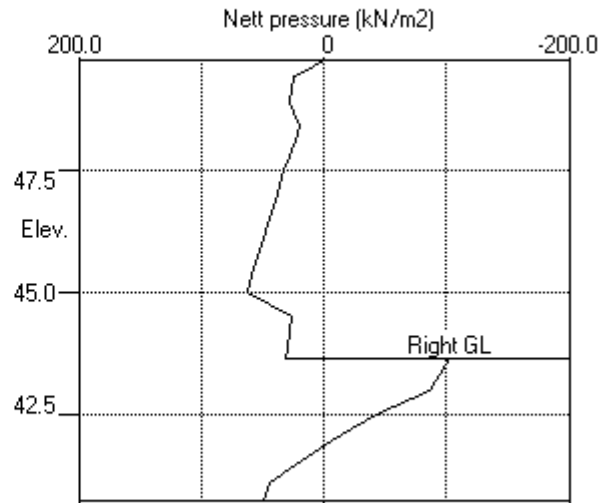
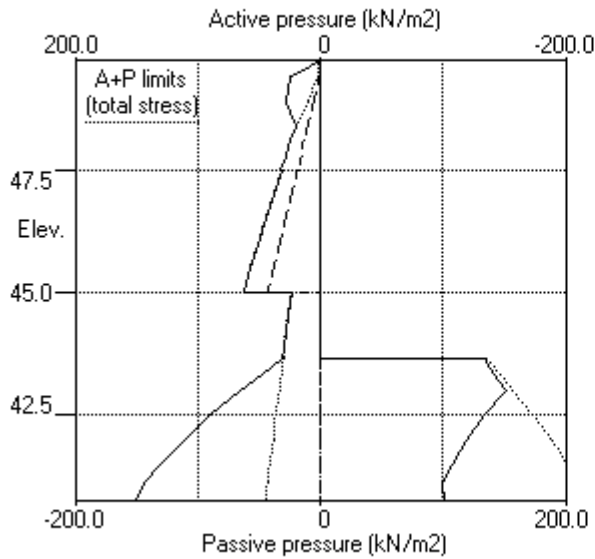

PILEDESIGNS LTD
 Program: WALLAP Version 6.06 Revision A51.B69.R54
 Licensed from GEOSOLVE
 Data filename/Run ID: Hampstead_Wall_6_450mm_rev_02_SLS
 Hampstead - 24-26 Redington Gardens
 Wall 6, Secant-SLS, 450 dia @ 650 - run 02

Sheet No.
 Job No. 21495
 Made by : DBS
 Date:30-11-2018
 Checked :

Units: kN,m

Stage No. 15 Change properties of soil type 3 to soil type 4
 Ko pressures will not be reset

STABILITY ANALYSIS of Fully Embedded Wall according to Strength Factor method
 Factor of safety on soil strength

Stage No.	--- G.L. --- Act. Pass.	Strut Elev.	FoS for toe elev. = 40.75	Moment of equil. at elev.	Toe elev. for FoS = 1.500	Wall Penetr- -ation	Direction of failure
15	49.75 43.65			More than one strut.	No FoS calc.		

BENDING MOMENT and DISPLACEMENT ANALYSIS of Fully Embedded Wall

Analysis options

Length of wall perpendicular to section = 50.00m
 Subgrade reaction model - Boussinesq Influence coefficients
 Soil deformations are elastic until the active or passive limit is reached
 Open Tension Crack analysis - No

Rigid boundaries: Left side 50.00 from wall
 Right side 50.00 from wall

Limit State: Serviceability Limit State

Calculated Bending Moments and Strut Forces are to be multiplied by a factor
 of 1.35 to obtain values for structural design. See summary for factored values.

*** Wall displacements reset to zero at stage 4

Node no.	Y coord	Nett pressure kN/m2	Wall disp. m	Wall rotation rad.	Shear force kN/m	Bending moment kN.m/m	Strut forces kN/m	EI of wall kN.m2/m
1	49.75	0.00	0.003	-2.67E-03	0.0	0.0		43355
2	49.50	15.34	0.003	-2.67E-03	1.9	0.2		43355
3	49.40	23.51	0.004	-2.67E-03	3.9	0.5		43355
4	48.90	28.13	0.005	-2.70E-03	16.8	4.8		43355
5	48.40	19.30	0.006	-2.83E-03	28.6	17.0	112.4	43355
		19.30	0.006	-2.83E-03	-83.8	17.0		
6	48.10	24.27	0.007	-2.87E-03	-77.3	-7.5		43355
7	47.80	28.87	0.008	-2.74E-03	-69.3	-29.7		43355
8	47.50	33.17	0.009	-2.48E-03	-60.0	-49.2		43355
		33.65	0.009	-2.48E-03	-60.0	-49.2		
9	47.00	40.97	0.010	-1.78E-03	-41.4	-75.2		43355
10	46.50	47.86	0.011	-8.51E-04	-19.1	-89.4		43355
11	46.00	54.37	0.011	1.80E-04	6.4	-93.8		43355
12	45.50	60.44	0.011	1.17E-03	35.1	-84.4		43355
13	45.00	65.92	0.010	1.98E-03	66.7	-59.8		43355
		64.55	0.010	1.98E-03	66.7	-59.8		
14	44.50	70.84	0.009	2.39E-03	100.5	-18.9		43355
15	44.17	74.94	0.008	2.38E-03	124.2	17.2		43355
16	43.85	79.04	0.007	2.06E-03	149.3	61.3	242.4	43355
		79.04	0.007	2.06E-03	-93.1	61.3		
17	43.65	81.58	0.007	1.79E-03	-77.1	45.1		43355
18	43.33	64.56	0.006	1.51E-03	-53.3	26.4		43355
19	43.00	47.55	0.006	1.35E-03	-35.1	13.1		43355
20	42.50	32.46	0.005	1.25E-03	-15.1	5.2		43355
21	42.00	17.39	0.004	1.22E-03	-2.6	-0.0		43355
22	41.50	2.34	0.004	1.24E-03	2.3	-1.2		43355
23	41.13	-5.38	0.003	1.25E-03	1.7	-0.5		43355

(continued)

Stage No.15 Change properties of soil type 3 to soil type 4
 Ko pressures will not be reset

Node no.	Y coord	----- RIGHT side -----					Total earth pressure kN/m2	Coeff. of subgrade reaction kN/m3
		Water press. kN/m2	Vertical kN/m2	Effective Active limit kN/m2	Effective Passive limit kN/m2	Earth pressure kN/m2		
15	44.17	0.00	0.00	0.00	0.00	0.00	0.0	
16	43.85	0.00	0.00	0.00	0.00	0.00	0.0	
17	43.65	0.00	0.00	0.00	0.00	0.00	0.0	
		0.00	0.00	0.00	0.00	0.00	10677	
18	43.33	0.00	6.50	2.28	21.14	21.14	21.14p 10982	
19	43.00	0.00	13.00	4.57	42.29	42.29	42.29p 11288	
20	42.50	4.90	18.10	6.36	58.86	58.86	63.77p 11758	
21	42.00	9.81	23.19	8.15	75.44	75.44	85.25p 12229	
22	41.50	14.71	28.29	9.94	92.02	92.02	106.73p 12699	
23	41.13	18.39	32.11	11.28	104.45	104.45	122.85p 13052	
24	40.75	22.07	35.94	12.62	116.89	104.86	126.93 13405	

Note: 109.08a Soil pressure at active limit
 122.85p Soil pressure at passive limit

Units: kN,m

Stage No.15 Change soil type 3 to soil type 4

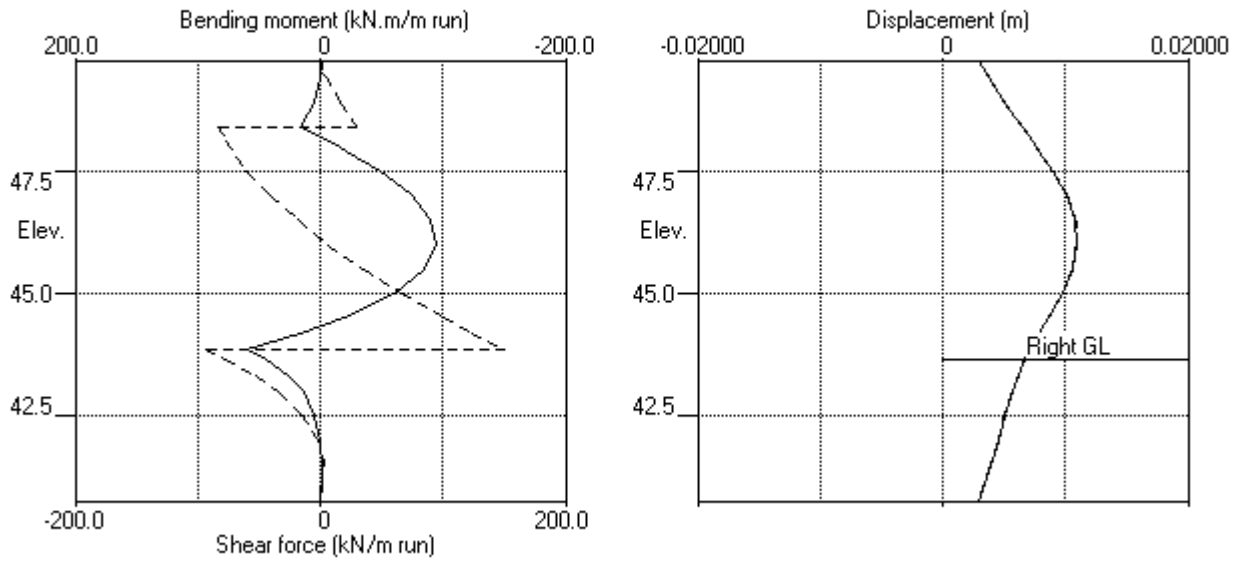

Stage No.15 Change soil type 3 to soil type 4

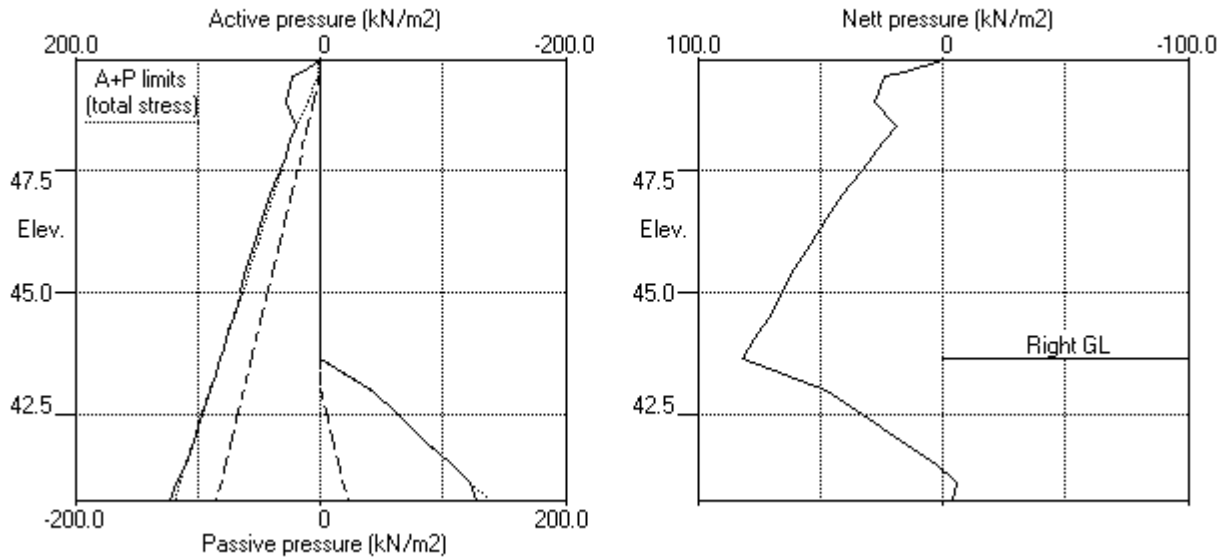

PILEDESIGNS LTD
 Program: WALLAP Version 6.06 Revision A51.B69.R54
 Licensed from GEOSOLVE
 Data filename/Run ID: Hampstead_Wall_6_450mm_rev_02_SLS
 Hampstead - 24-26 Redington Gardens
 Wall 6, Secant-SLS, 450 dia @ 650 - run 02

Sheet No.
 Job No. 21495
 Made by : DBS
 Date: 30-11-2018
 Checked :

 Units: kN,m

Summary of results

LIMIT STATE PARAMETERS

Limit State: Serviceability Limit State
 All loads and soil strengths are unfactored

STABILITY ANALYSIS of Fully Embedded Wall according to Strength Factor method
 Factor of safety on soil strength

Stage No.	G.L.		Strut Elev.	FoS for toe elev. = 40.75		Toe elev. for FoS = 1.500		Direction of failure
	Act.	Pass.		Factor of Safety	Moment at elev.	Toe elev.	Wall Penetration	
1	49.75	49.75	Cant.	Conditions not suitable for FoS calc.				
2	49.75	49.75		No analysis at this stage				
3	49.75	49.75		No analysis at this stage				
4	49.75	49.75		No analysis at this stage				
5	49.75	49.75		No analysis at this stage				
6	49.75	49.75		No analysis at this stage				
7	49.75	49.75		No analysis at this stage				
8	49.75	49.75	Cant.	Conditions not suitable for FoS calc.				
9	49.75	48.10	Cant.	2.227	41.82	42.80	5.30	L to R
10	49.75	48.10		No analysis at this stage				
11	49.75	48.10	48.40	6.272	n/a	46.70	1.40	L to R
12	49.75	43.65	48.40	1.969	n/a	42.37	1.28	L to R
13	49.75	43.65		No analysis at this stage				

All remaining stages have more than one strut - FoS calculation n/a

PILEDESIGNS LTD
 Program: WALLAP Version 6.06 Revision A51.B69.R54
 Licensed from GEOSOLVE
 Data filename/Run ID: Hampstead_Wall_6_450mm_rev_02_SLS
 Hampstead - 24-26 Redington Gardens
 Wall 6, Secant-SLS, 450 dia @ 650 - run 02

Sheet No.
 Job No. 21495
 Made by : DBS
 Date: 30-11-2018
 Checked :

Units: kN,m

Summary of results

BENDING MOMENT and DISPLACEMENT ANALYSIS of Fully Embedded Wall

Analysis options

Length of wall perpendicular to section = 50.00m
 Subgrade reaction model - Boussinesq Influence coefficients
 Soil deformations are elastic until the active or passive limit is reached
 Open Tension Crack analysis - No

Rigid boundaries: Left side 50.00 from wall
 Right side 50.00 from wall

Limit State: Serviceability Limit State

Calculated Bending Moments and Strut Forces have been multiplied by a factor of 1.35 to obtain values for structural design.

Bending moment, shear force and displacement envelopes

Node no.	Y coord	Displacement		Bending moment				Shear force			
		max. m	min. m	Calculated kN.m/m		Factored kN.m/m		Calculated kN/m		Factored kN/m	
1	49.75	0.009	0.000	0	0	0	0	0	0	0	0
2	49.50	0.009	0.000	0	-0	0	-0	2	-1	3	-1
3	49.40	0.009	0.000	1	-0	1	-0	4	-1	6	-2
4	48.90	0.007	0.000	5	-1	7	-2	18	-3	24	-5
5	48.40	0.006	0.000	18	-3	24	-4	30	-90	40	-122
6	48.10	0.007	0.000	9	-9	12	-12	18	-84	24	-113
7	47.80	0.008	0.000	15	-33	20	-44	23	-76	31	-102
8	47.50	0.009	0.000	22	-54	30	-72	25	-66	34	-90
9	47.00	0.010	0.000	33	-83	45	-112	18	-49	24	-66
10	46.50	0.011	0.000	40	-100	55	-136	5	-28	6	-38
11	46.00	0.011	0.000	39	-109	53	-147	6	-7	9	-10
12	45.50	0.011	0.000	34	-105	46	-142	35	-12	47	-16
13	45.00	0.010	0.000	27	-87	37	-117	67	-14	90	-18
14	44.50	0.009	0.000	20	-58	27	-78	101	-14	136	-18
15	44.17	0.008	0.000	17	-35	23	-47	124	-12	168	-17
16	43.85	0.007	0.000	61	-10	83	-13	149	-93	201	-126
17	43.65	0.007	0.000	45	0	61	0	89	-77	120	-104
18	43.33	0.006	0.000	39	0	53	0	55	-53	75	-72
19	43.00	0.006	0.000	48	0	64	0	23	-35	31	-47
20	42.50	0.005	0.000	49	0	66	0	0	-22	0	-30
21	42.00	0.004	0.000	35	-0	47	-0	0	-34	0	-47
22	41.50	0.004	0.000	16	-1	22	-2	2	-33	3	-44
23	41.13	0.003	0.000	5	-0	7	-1	2	-21	2	-29
24	40.75	0.003	0.000	0	-0	0	-0	0	-0	0	-0

Summary of results (continued)

Calculated Bending Moments and Strut Forces have been multiplied by a factor of 1.35 to obtain values for structural design.

Maximum and minimum bending moment and shear force at each stage

Stage no.	Bending moment				Shear force			
	Calculated		Factored		Calculated		Factored	
min.	max. elev.	min. elev.	max. elev.	max. elev.	min. elev.	max. elev.	min. elev.	max. elev.
	kN.m/m	kN.m/m	kN.m/m	kN/m	kN/m	kN/m	kN/m	kN/m
1	0 43.85	-0 47.50	1 -0	0 45.00	-0 48.90	1		
-0								
2	No calculation at this stage							
3	No calculation at this stage							
4	No calculation at this stage							
5	No calculation at this stage							
6	No calculation at this stage							
7	No calculation at this stage							
8	6 44.17	-4 47.80	8 -5	6 45.00	-3 48.90	8		
-5								
9	40 46.50	-0 40.75	55 -0	25 47.50	-14 44.50	34		
-18								
10	No calculation at this stage							
11	33 46.50	-0 40.75	45 -0	21 47.50	-9 44.17	28		
-12								
12	49 42.50	-109 46.00	66 -147	89 43.65	-90 48.40	120		
-122								
13	No calculation at this stage							
14	48 42.50	-102 46.00	65 -137	87 43.85	-86 48.40	118		
-116								
15	61 43.85	-94 46.00	83 -127	149 43.85	-93 43.85	201		
-126								
16	No calculation at this stage							
17	42 43.85	-99 46.00	57 -133	142 43.85	-85 48.40	192		
-115								

Maximum and minimum displacement at each stage

Stage no.	Displacement				Stage description
	maximum	elev.	minimum	elev.	
	m	m	m	m	
1	0.000	49.75	0.000	49.75	Apply surcharge no.1 at elev. 49.75
2	No calculation at this stage				Apply surcharge no.2 at elev. 49.50
3	No calculation at this stage				Apply surcharge no.3 at elev. 49.75
4	Wall displacements reset to zero				Change EI of wall to 60696kN.m ² /m run
5	No calculation at this stage				Apply surcharge no.4 at elev. 49.75
6	No calculation at this stage				Apply surcharge no.5 at elev. 49.50
7	No calculation at this stage				Apply surcharge no.6 at elev. 49.75
8	0.002	49.75	0.000	49.75	Apply water pressure profile no.1
9	0.009	49.75	0.000	49.75	Excav. to elev. 48.10 on RIGHT side
10	No calculation at this stage				Install strut no.1 at elev. 48.40
11	0.009	49.75	0.000	49.75	Apply water pressure profile no.2
12	0.010	46.00	0.000	49.75	Excav. to elev. 43.65 on RIGHT side
13	No calculation at this stage				Install strut no.2 at elev. 43.85
14	0.011	46.00	0.000	49.75	Change EI of wall to 43355kN.m ² /m run
15	0.011	46.00	0.000	49.75	Change soil type 3 to soil type 4
16	No calculation at this stage				Apply surcharge no.7 at elev. 43.65
17	0.011	46.00	0.000	49.75	Apply water pressure profile no.3

Summary of results (continued)

Calculated Bending Moments and Strut Forces have been multiplied by a factor of 1.35 to obtain values for structural design.

Strut forces at each stage (horizontal components)

Stage no.	----- Strut no. 1 ----- at elev. 48.40			----- Strut no. 2 ----- at elev. 43.85		
	--Calculated-- kN per m run	Factored kN per strut	Factored kN per strut	--Calculated-- kN per m run	Factored kN per strut	Factored kN per strut
11	6	6	7	---	---	---
12	119	119	160	---	---	---
14	116	116	156	22	22	30
15	112	112	152	242	242	327
17	115	115	155	196	196	264

Units: kN,m

Bending moment, shear force, displacement envelopes

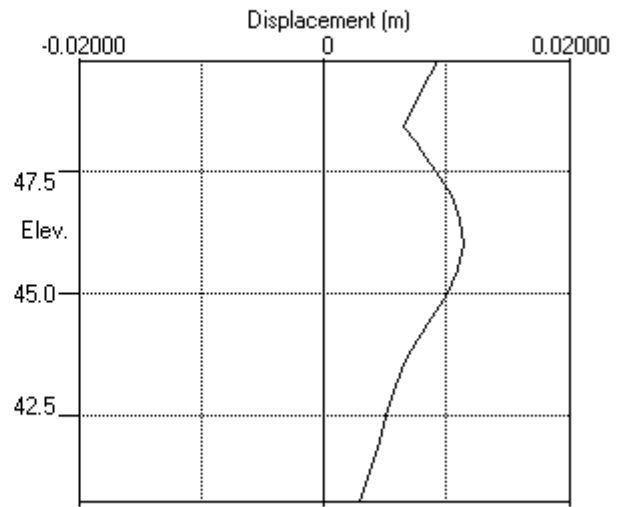
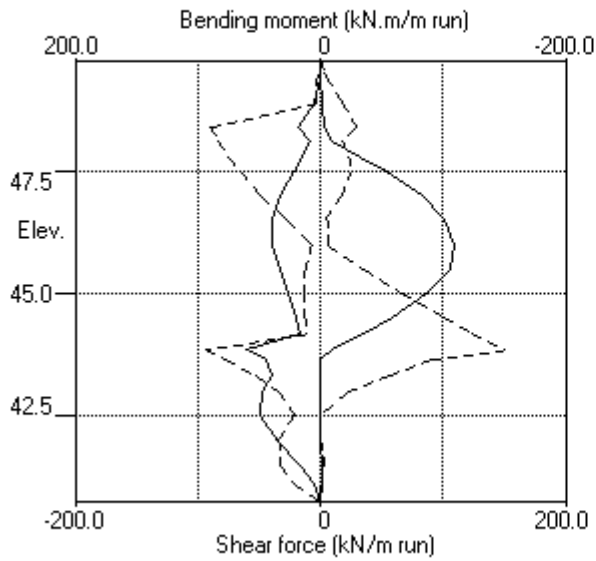



APPENDIX B

Ref No	Description
B1	Results of “ADCOL” analysis for 450mm diameter wall piles with 5 x B25mm bars, 0kN compression load (Walls 1 & 5).
B2	Results of “ADCOL” analysis for 450mm diameter wall piles with 6 x B20mm bars, 0kN compression load (Wall 2 & 3).
B3	Results of “ADCOL” analysis for 450mm diameter wall piles with 5 x B20mm bars, 0kN compression load (Wall 4).
B4	Results of “ADCOL” analysis for 450mm diameter wall piles with 6 x B25mm bars, 0kN compression load (Wall 6).
B5	Results of Helical Check for 450mm diameter wall piles with 5 x B25mm bars, B10mm helical @ 200mm centres, 75mm cover (Wall 1 & 5).
B6	Results of Helical Check for 450mm diameter wall piles with 6 x B20mm bars, B10mm helical @ 200mm centres, 75mm cover (Wall 2 & 3).
B7	Results of Helical Check for 450mm diameter wall piles with 5 x B20mm bars, B10mm helical @ 200mm centres, 75mm cover (Wall 4).
B8	Results of Helical Check for 450mm diameter wall piles with 6 x B25mm bars, B10mm helical @ 200mm centres, 75mm cover (Wall 6).

Job No.	Sheet No.	Rev.
21495	B1	
Drg. Ref.		
Made by DBS	Date 11-Nov-2018	Checked

Reinforcement Details

Bar Arrangement	1 ring(s)/5 bars per ring
Diameter of main bars	25mm
Area of reinforcement	2454.37mm ²
Nominal Cover (outer)	75mm

Design Results

Analysis Case Name	Analysis Case 1
Axial Design Force	-100kN
Axial Capacity	3401.76kN
Design Moment 'M'	0kNm
Ultimate Moment 'Mu'	125.456kNm
Neutral Axis	— — —
Comp./Tens. Side	+/-
Governing Node/Bar	X

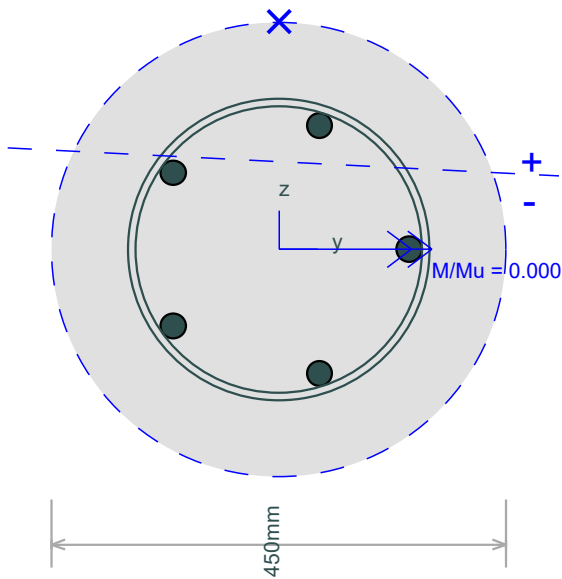

Section 1
Analysis Case 1

Job No.	Sheet No.	Rev.
21495	B2	
Drg. Ref.		
Made by DBS	Date 11-Nov-2018	Checked

Reinforcement Details

Bar Arrangement	1 ring(s)/6 bars per ring
Diameter of main bars	20mm
Area of reinforcement	1884.96mm ²
Nominal Cover (outer)	75mm

Design Results

Analysis Case Name	Analysis Case 1
Axial Design Force	-100kN
Axial Capacity	3182.79kN
Design Moment 'M'	0kNm
Ultimate Moment 'Mu'	102.827kNm
Neutral Axis	— — —
Comp./Tens. Side	+/-
Governing Node/Bar	X

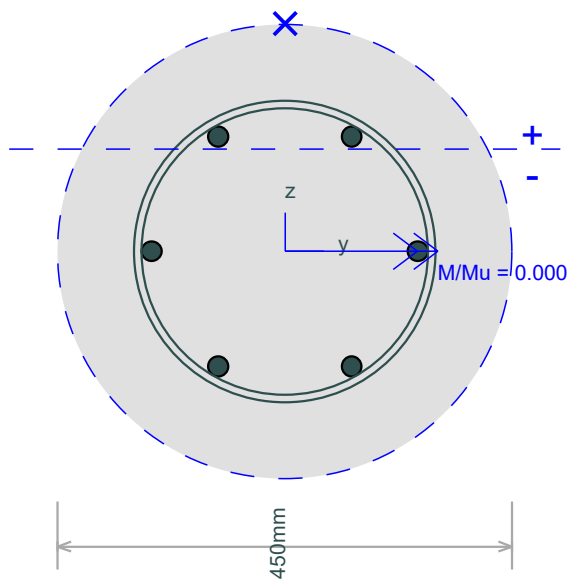
Section 1
 Analysis Case 1

Job No.	Sheet No.	Rev.
21495	B3	
Drg. Ref.		
Made by DBS	Date 30-Nov-2018	Checked

Reinforcement Details

Bar Arrangement	1 ring(s)/5 bars per ring
Diameter of main bars	20mm
Area of reinforcement	1570.8mm ²
Nominal Cover (outer)	75mm

Design Results

Analysis Case Name	Analysis Case 1
Axial Design Force	-100kN
Axial Capacity	3061.98kN
Design Moment 'M'	0kNm
Ultimate Moment 'Mu'	86.0528kNm
Neutral Axis	— — —
Comp./Tens. Side	+/-
Governing Node/Bar	X

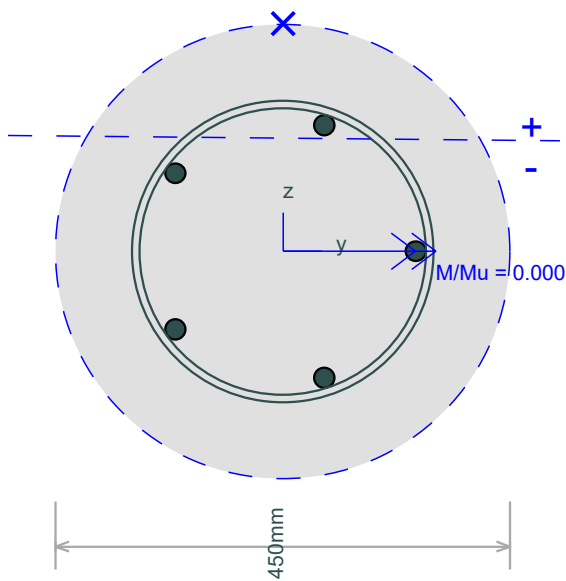

Section 1
Analysis Case 1

Job No.	Sheet No.	Rev.
21495	B4	
Drg. Ref.		
Made by DBS	Date 11-Nov-2018	Checked

Reinforcement Details

Bar Arrangement	1 ring(s)/6 bars per ring
Diameter of main bars	25mm
Area of reinforcement	2945.24mm ²
Nominal Cover (outer)	75mm

Design Results

Analysis Case Name	Analysis Case 1
Axial Design Force	-100kN
Axial Capacity	3590.52kN
Design Moment 'M'	0kNm
Ultimate Moment 'Mu'	145.389kNm
Neutral Axis	— — —
Comp./Tens. Side	+/-
Governing Node/Bar	X

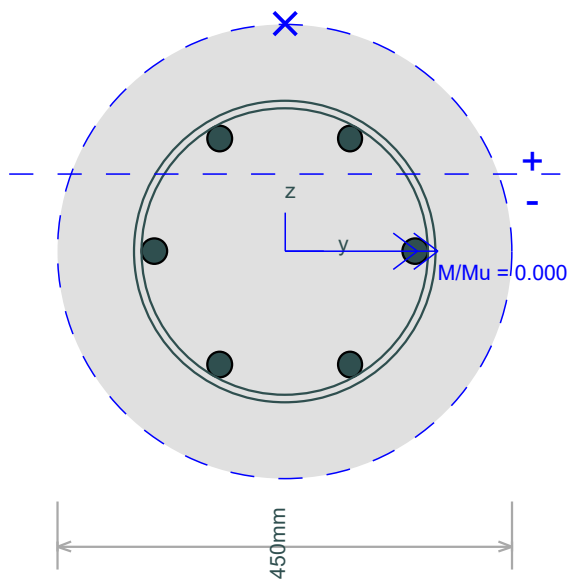

Section 1
Analysis Case 1

Project	HAMPSTEAD - 24-26 Redington Gardens	Project No.	21495	Date	03/12/2018
Titile	450mm Pile Shear Check - Walls 1 & 5	By	DBS	Check By	Page 1

REFERENCE
EC2
Shear to EN 1992-1-1:2004 (EC2) Circular Sections (Cast In-situ) using helical reinforcement
Pile section

4.4.1.3(4)	pile dia d_{nom} =	450 mm		
	design pile diameter =	450 mm		
	A_c =	159043 mm ²		
	cover c_{nom} =	75 mm	$k_2 =$	75 mm [NA.1 4.4.1.3 (4)]
	main bar dia =	25 mm		
	no. main bars =	5 no.		
	helical dia. =	10 mm		
	d =	298 mm	$\gamma_c =$	1.5 (This is adjusted by $K_f=1.1$ [2.4.2.5 (2)] to give 1.65)
	f_{ck} =	30 MPa	$\gamma_c =$	1.65 $\alpha_{cc} =$
	f_{yk} =	500 MPa	$\gamma_s =$	1.15
	Ult V_{Ed} =	129.7 kN	SF factor	1
	Ult V_{Ed} =	129.7 kN		
	factored action: N_{Ed} =	-70 kN		

6.2.2

Check requirement for shear reinforcement

$V_{Rd,c}$ =	$[C_{Rd,c}k(100\rho_1f_{ck})^{1/3}+k_1\sigma_{cp}]b_wd$	$CR_{d,c} =$	0.18 / γ_c	0.11
with minimum =	$(v_{min}+k_1\sigma_{cp})b_wd$	$k =$	$1+(200/d)^{1/2}$	1.82 ≤ 2.0
$v_{min} =$	$0.035k^{3/4}f_{ck}^{1/2}$	$\rho_1 =$	A_{sl}/b_wd	0.01 ≤ 0.02
	0.4703	$\sigma_{cp} =$	N_{ed}/A_c	-0.44 $< 0.2f_{cd}$
		$k_1 =$	0.15	[NA.1 6.2.2(1)]

$$V_{Rd,c} = 54 \text{ kN}$$

 Is $V_{Rd,c} > V_{Ed}$ \Rightarrow **NO** Action: **Design of shear reinforcement required**

6.2.3

Design Shear Reinforcement

 Check concrete strut capacity at $\cot \theta = 2.5$:-

 6.2.3 (3)
exp 6.9

$V_{Rd,max} =$	$\alpha_{cw} \cdot b_w \cdot z \cdot V_1 \cdot f_{cd} / (\cot \theta + \tan \theta)$	(6.9)	$\cot \theta =$	1
			$\tan \theta =$	1
$V_{Rd,max} =$	493 kN		$\alpha_{cw} =$	1 [NA.1 6.2.3(3)]
			$z =$	0.9d 268 mm
			$V_1 =$	0.6 (1-($f_{ck}/250$)) 0.53 [6.6N]

 Is $V_{Rd,c} > V_{Ed}$ \Rightarrow **YES** Action: **Calculate link spacing**

Calculation for strut inclination:-

$$\theta = 0.5 \cdot \sin^{-1} [(6.54 \cdot V_{Ed}) / (b_w \cdot d \cdot (1 - f_{ck}/250) \cdot f_{ck})]$$

$$\theta = \text{NA rad} \quad \cot \theta = 2.5 > 1.0$$

Calculate shear reinforcement spacing after Turmo et al (2008):-

$$V_{Rd,s} = z \cdot \cot \theta \cdot (A_\phi / 0.5s) \cdot f_{ywd} \cdot 0.85$$

$$s = 2 \cdot ([z \cdot \cot \theta \cdot A_\phi \cdot f_{ywd} \cdot 0.85] / V_{Rd,s})$$

$$s = 300 \text{ mm}$$

$A_\phi =$	78.5 mm ²
$f_{ywd} =$	435 MPa

Provide 10 mm helical at nominal pitch 200 mm

Project	HAMPSTEAD - 24-26 Redington Gardens	Project No.	21495	Date	03/12/2018
Titile	450mm Pile Shear Check - Walls 2 & 3	By	DBS	Check By	Page 1

REFERENCE
EC2
Shear to EN 1992-1-1:2004 (EC2) Circular Sections (Cast In-situ) using helical reinforcement
Pile section

4.4.1.3(4)	pile dia d_{nom} =	450 mm		
	design pile diameter =	450 mm		
	A_c =	159043 mm ²		
	cover c_{nom} =	75 mm	$k_2 =$	75 mm [NA.1 4.4.1.3 (4)]
	main bar dia =	20 mm		
	no. main bars =	6 no.		
	helical dia. =	10 mm		
	d =	301 mm	$\gamma_c =$	1.5 (This is adjusted by $K_f=1.1$ [2.4.2.5 (2)] to give 1.65)
	f_{ck} =	30 MPa	$\gamma_c =$	1.65 $\alpha_{cc} =$
	f_{yk} =	500 MPa	$\gamma_s =$	1.15
	Ult V_{Ed} =	117.9 kN	SF factor	1
	Ult V_{Ed} =	117.9 kN		
	factored action: N_{Ed} =	-75 kN		

6.2.2

Check requirement for shear reinforcement

$V_{Rd,c}$ =	$[C_{Rd,c}k(100\rho_1f_{ck})^{1/3}+k_1\sigma_{cp}]b_wd$	$CR_{d,c}$ =	$0.18 / \gamma_c$	0.11
with minimum	$= (v_{min}+k_1\sigma_{cp})b_wd$	k =	$1+(200/d)^{1/2}$	1.81 ≤ 2.0
v_{min} =	$0.035k^{3/2}f_{ck}^{1/2}$	ρ_1 =	A_s/b_wd	0.01 ≤ 0.02
	0.4686	σ_{cp} =	N_{ed}/A_c	-0.47 $< 0.2f_{cd}$
		k_1 =	0.15	[NA.1 6.2.2(1)]

$$V_{Rd,c} = 54 \text{ kN}$$

 Is $V_{Rd,c} > V_{Ed}$ \Rightarrow **NO** Action: **Design of shear reinforcement required**

6.2.3

Design Shear Reinforcement

 Check concrete strut capacity at $\cot \theta = 2.5$:-

6.2.3 (3) exp 6.9	$V_{Rd,max}$ =	$\alpha_{cw} \cdot b_w \cdot z \cdot v_1 \cdot f_{cd} / (\cot \theta + \tan \theta)$ (6.9)	$\cot \theta$ =	1
			$\tan \theta$ =	1
	$V_{Rd,max}$ =	498 kN	α_{cw} =	1 [NA.1 6.2.3(3)]
			z =	0.9d 271 mm
			v_1 =	0.6 (1-($f_{ck}/250$)) 0.53 [6.6N]

 Is $V_{Rd,c} > V_{Ed}$ \Rightarrow **YES** Action: **Calculate link spacing**

Calculation for strut inclination:-

θ =	$0.5 \cdot \sin^{-1}[(6.54 \cdot V_{Ed}) / (b_w \cdot d \cdot (1 - f_{ck}/250) \cdot f_{ck})]$	$\cot \theta$ =	2.5 > 1.0
θ =	NA rad		

Calculate shear reinforcement spacing after Turmo et al (2008):-

$V_{Rd,s}$ =	$z \cdot \cot \theta \cdot (A_\phi / 0.5s) \cdot f_{ywd} \cdot 0.85$	A_ϕ =	78.5 mm ²
s =	$2 \cdot ([z \cdot \cot \theta \cdot A_\phi \cdot f_{ywd} \cdot 0.85] / V_{Rd,s})$	f_{ywd} =	435 MPa
	334 mm		

Provide 10 mm helical at nominal pitch 225 mm

Project	HAMPSTEAD - 24-26 Redington Gardens	Project No.	21495	Date	03/12/2018
Title	450mm Pile Shear Check - Wall 4	By	DBS	Check By	Page 1

REFERENCE
EC2
Shear to EN 1992-1-1:2004 (EC2) Circular Sections (Cast In-situ) using helical reinforcement
Pile section

4.4.1.3(4)	pile dia d_{nom} =	450 mm		
	design pile diameter =	450 mm		
	A_c =	159043 mm ²		
	cover c_{nom} =	75 mm	$k_2 =$	75 mm [NA.1 4.4.1.3 (4)]
	main bar dia =	20 mm		
	no. main bars =	5 no.		
	helical dia. =	10 mm		
	d =	301 mm	$\gamma_c =$	1.5 (This is adjusted by $K_f=1.1$ [2.4.2.5 (2)] to give 1.65)
	f_{ck} =	30 MPa	$\gamma_c =$	1.65 $\alpha_{cc} =$
	f_{yk} =	500 MPa	$\gamma_s =$	1.15
	Ult V_{Ed} =	85.4 kN	SF factor	1
	Ult V_{Ed} =	85.4 kN		
	factored action: N_{Ed} =	-75 kN		

6.2.2

Check requirement for shear reinforcement

$V_{Rd,c}$ =	$[C_{Rd,c}k(100\rho_1f_{ck})^{1/3}+k_1\sigma_{cp}]b_wd$	$CR_{d,c}$ =	$0.18 / \gamma_c$	0.11
with minimum =	$(v_{min}+k_1\sigma_{cp})b_wd$	k =	$1+(200/d)^{1/2}$	1.81 ≤ 2.0
v_{min} =	$0.035k^{3/2}f_{ck}^{1/2}$	ρ_1 =	A_s/b_wd	0.01 ≤ 0.02
	0.4686	σ_{cp} =	N_{ed}/A_c	-0.47 $< 0.2f_{cd}$
		k_1 =	0.15	[NA.1 6.2.2(1)]

$$V_{Rd,c} = 54 \text{ kN}$$

Is $V_{Rd,c} > V_{Ed}$ \Rightarrow **NO** Action: **Design of shear reinforcement required**

6.2.3

Design Shear Reinforcement

 Check concrete strut capacity at $\cot \theta = 2.5$:-

 6.2.3 (3)
exp 6.9

$V_{Rd,max}$ =	$\alpha_{cw} \cdot b_w \cdot z \cdot v_1 \cdot f_{cd} / (\cot \theta + \tan \theta)$	(6.9)	$\cot \theta =$	1
			$\tan \theta =$	1
			$\alpha_{cw} =$	1 [NA.1 6.2.3(3)]
			$z =$	0.9d
$V_{Rd,max}$ =	498 kN		$v_1 =$	0.6 (1-($f_{ck}/250$))
				0.53 [6.6N]

Is $V_{Rd,c} > V_{Ed}$ \Rightarrow **YES** Action: **Calculate link spacing**

Calculation for strut inclination:-

$\theta =$	$0.5 \cdot \sin^{-1} [(6.54 \cdot V_{Ed}) / (b_w \cdot d \cdot (1 - f_{ck}/250) \cdot f_{ck})]$		$\cot \theta =$	2.5 > 1.0
$\theta =$	NA rad			

Calculate shear reinforcement spacing after Turmo et al (2008):-

$V_{Rd,s}$ =	$z \cdot \cot \theta \cdot (A_\phi / 0.5s) \cdot f_{ywd} \cdot 0.85$	$A_\phi =$	78.5 mm ²
s =	$2 \cdot ([z \cdot \cot \theta \cdot A_\phi \cdot f_{ywd} \cdot 0.85] / V_{Rd,s})$	$f_{ywd} =$	435 MPa
	461 mm		

Provide 10 mm helical at nominal pitch	225 mm
--	--------

Project	HAMPSTEAD - 24-26 Redington Gardens	Project No.	21495	Date	03/12/2018
Tilte	450mm Pile Shear Check - Wall 6	By	DBS	Check By	Page 1

REFERENCE
EC2
Shear to EN 1992-1-1:2004 (EC2) Circular Sections (Cast In-situ) using helical reinforcement
Pile section

4.4.1.3(4)	pile dia d_{nom} =	450 mm		
	design pile diameter =	450 mm		
	A_c =	159043 mm ²		
	cover c_{nom} =	75 mm	$k_2 =$	75 mm [NA.1 4.4.1.3 (4)]
	main bar dia =	25 mm		
	no. main bars =	6 no.		
	helical dia. =	10 mm		
	d =	298 mm	$\gamma_c =$	1.5 (This is adjusted by $K_f=1.1$ [2.4.2.5 (2)] to give 1.65)
	f_{ck} =	30 MPa	$\gamma_c =$	1.65 $\alpha_{cc} =$
	f_{yk} =	500 MPa	$\gamma_s =$	1.15
	Ult V_{Ed} =	140 kN	SF factor	1
	Ult V_{Ed} =	140 kN		
	factored action: N_{Ed} =	-70 kN		

6.2.2

Check requirement for shear reinforcement

$V_{Rd,c}$ =	$[C_{Rd,c}k(100\rho_1f_{ck})^{1/3}+k_1\sigma_{cp}]b_wd$	$CR_{d,c}$ =	$0.18 / \gamma_c$	0.11
with minimum	$= (v_{min}+k_1\sigma_{cp})b_wd$	k =	$1+(200/d)^{1/2}$	1.82 ≤ 2.0
v_{min} =	$0.035k^{3/2}f_{ck}^{1/2}$	ρ_1 =	A_{sl}/b_wd	0.01 ≤ 0.02
	0.4703	σ_{cp} =	N_{ed}/A_c	-0.44 $< 0.2f_{cd}$
		k_1 =	0.15	[NA.1 6.2.2(1)]

$$V_{Rd,c} = 54 \text{ kN}$$

Is $V_{Rd,c} > V_{Ed}$ \Rightarrow **NO** Action: **Design of shear reinforcement required**

6.2.3

Design Shear Reinforcement

Check concrete strut capacity at $\cot \theta = 2.5$:-

6.2.3 (3) exp 6.9	$V_{Rd,max}$ =	$\alpha_{cw} \cdot b_w \cdot z \cdot V_1 \cdot f_{cd} / (\cot \theta + \tan \theta)$ (6.9)	$\cot \theta$ =	1
			$\tan \theta$ =	1
	$V_{Rd,max}$ =	493 kN	α_{cw} =	1 [NA.1 6.2.3(3)]
			z =	0.9d 268 mm
			V_1 =	0.6 (1-($f_{ck}/250$)) 0.53 [6.6N]

Is $V_{Rd,c} > V_{Ed}$ \Rightarrow **YES** Action: **Calculate link spacing**

Calculation for strut inclination:-

$$\theta = 0.5 \cdot \sin^{-1} [(6.54 \cdot V_{Ed}) / (b_w \cdot d \cdot (1 - f_{ck}/250) \cdot f_{ck})]$$

$$\theta = \text{NA rad}$$

$$\cot \theta = 2.5 > 1.0$$

Calculate shear reinforcement spacing after Turmo et al (2008):-

$V_{Rd,s}$ =	$z \cdot \cot \theta \cdot (A_\phi / 0.5s) \cdot f_{ywd} \cdot 0.85$	A_ϕ =	78.5 mm ²
s =	$2 \cdot ([z \cdot \cot \theta \cdot A_\phi \cdot f_{ywd} \cdot 0.85] / V_{Rd,s})$	f_{ywd} =	435 MPa
	278 mm		

Provide 10 mm helical at nominal pitch 200 mm



APPENDIX C

Ref No	Description
C1	Results of "PILE" analysis for 450mm diameter bearing piles based on piling level of 49.75mAD and discounted level of 42.9mAD - bearing piles with cut-off levels of 43.007-43.505mAD.
C2	Results of "PILE" analysis for 450mm diameter bearing piles based on piling level of 49.75mAD and discounted level of 43.7mAD - bearing piles with cut-off levels of 43.805-44.132mAD.
C3	Results of "PILE" analysis for 450mm diameter wall piles based on piling level of 49.75mAD and discounted level of 43.6mAD.

Job No.	Sheet No.	Rev.
21495	C1	
Drg. Ref.		
Made by DBS	Date	Checked

Notes

PPL = 49.75mAD

Analysis Options

Design approach: DA1(C1 + C2)
 Pile type: CFA
 Model factor: 1.40
 Partial factor on negative skin friction - Set A1: 1.00
 Partial factor on negative skin friction - Set A2: 1.00
 Serviceability verified by load tests (preliminary/working) carried out on more than 1% of constructed piles to loads not less than 1.5 times the representative load for which they are designed? No
 Resistance verified by a maintained load test taken to the calculated, unfactored, ultimate resistance? No
 Datum type: Elevation based
 Effective stress profile: Calculated

Pile Properties

Pile type: Solid
 Pile cross-section: Circular
 Under-ream: No
 Calculation profile: Range
 Minimum pile length: 10.000 m
 Maximum pile length: 26.000 m
 Increment size: 0.50000

Cross-section	Number of cross sections	Top Diameter [m]	Second Diameter location [m]	Second Diameter [m]	Third Diameter location [m]	Third Diameter [m]
Cross-section 1	1	0.45000				

Undrained Materials - General Data

No.	Material description	Bulk unit weight [kN/m ³]	Cu material factor	Top Cu [kPa]	Base Cu [kPa]
1	Discounted Soil	18.000	NA	0.0	0.0
2	London Clay	20.000	NA	60.500	100.00
3	London Clay 2	20.000	NA	100.00	250.00
4	London Clay 3	20.000	NA	250.00	250.00

Undrained Materials - Skin Friction Data

No.	Material description	Skin friction computation	Alpha	q _s Top [kPa]	q _s Base [kPa]	Spec. Value [kPa]	q _{s,lim}
1	Discounted Soil	Alpha specified	0.0	NA	NA	No	NA
2	London Clay	Alpha specified	0.60000	NA	NA	No	NA
3	London Clay 2	Alpha specified	0.60000	NA	NA	No	NA
4	London Clay 3	Alpha specified	0.60000	NA	NA	No	NA

Undrained Materials - End Bearing Data

No.	Material description	End bearing computation	Nc	q _b Top [kPa]	q _b Base [kPa]	Spec. Value [kPa]	q _{b,lim}
-----	----------------------	-------------------------	----	--------------------------	---------------------------	-------------------	--------------------

Hampstead - 24-26 Redington Gardens
 450mm dia pile 42.9mAD discounted
 vertical capacity

Job No.	Sheet No.	Rev.
21495	C1	
Drg. Ref.		
Made by DBS	Date	Checked

No.	Material description	End bearing computation	Nc	Q _b	Q _{b,lim}
				Top [kPa]	Base Spec. Value [kPa]
1	Discounted Soil	Nc specified	0.0	NA	NA No NA
2	London Clay	Nc specified	9.0000	NA	NA No NA
3	London Clay 2	Nc specified	9.0000	NA	NA No NA
4	London Clay 3	Nc specified	9.0000	NA	NA No NA

Undrained Materials - Material Factors (Code Based)

No.	Material description	Qs factors		Nc factors		Qb factors	
		M1	M2	M1	M2	M1	M2
1	Discounted Soil	N.A.	N.A.	1.0000	1.0000	N.A.	N.A.
2	London Clay	N.A.	N.A.	1.0000	1.0000	N.A.	N.A.
3	London Clay 2	N.A.	N.A.	1.0000	1.0000	N.A.	N.A.
4	London Clay 3	N.A.	N.A.	1.0000	1.0000	N.A.	N.A.

STAGE SPECIFIC DATA

Stage 0 : Initial Stage

Groundwater

No.	Level [m]	Pressure [kPa]	Unit weight of water [kN/m ³]
1	49.400	0.0	9.8100

Soil Profiles

Soil Profile 1: Soil Profile 1

No.	Level [mOD]	Material description	Contributes to negative skin friction
1	49.750	Air/Void	No
2	44.000	Discounted Soil	No
3	42.900	London Clay	No
4	35.000	London Clay 2	No
5	20.000	London Clay 3	No

Soil Profile - Groundwater Map

No.	Soil Profile	Groundwater
1	Soil Profile 1	Groundwater Profile 1

Stage specific warnings

- 1 - Stage 0 - The bottom most layer in Soil Profile 1 is assigned "Total stress" material. For this layer the cohesion is assumed to be constant at "Cu-Top", i.e cohesion specified at the top of this layer. The user specified value of cohesion at the bottom of this layer, "Cu-Bottom" is ignored. (Material Properties)

CAPACITY RESULTS

Partial Resistance Factors Used:

DA1 C1

Shaft resistance factor for set R1 (Compression):	1.00
Base resistance factor for set R1:	1.00
Shaft resistance factor for set R1 (Tension):	1.00

Hampstead - 24-26 Redington Gardens
 450mm dia pile 42.9mAD discounted
 vertical capacity

Job No.	Sheet No.	Rev.
21495	C1	
Drg. Ref.		
Made by	Date	Checked
DBS		

No. Soil Profile Groundwater

DA1 C2

Shaft resistance factor for set R4 (Compression): 1.60
 Base resistance factor for set R4: 2.00
 Shaft resistance factor for set R4 (Tension): 2.00
 Model factor: 1.40

Stress Profiles

Soil Profile 1: Soil Profile 1

Level	Density	Undrained Cohesion	Nq	Total vertical stress	Porewater pressure	Effective vertical stress	Effective horizontal stress*	Cumulative skin friction per unit perimeter
[mOD]	[kN/m ³]	[kPa]		[kPa]	[kPa]	[kPa]	[kPa]	[kN/m]
49.750	0.0	0.0	0.0	0.0	0.0	0.0	NA	0.0
49.400	9.8100	0.0	0.0	0.0	0.0	0.0	NA	0.0
44.000	9.8100	0.0	0.0	52.974	52.974	0.0	NA	0.0
44.000	18.000	0.0	N.A.	52.974	52.974	0.0	NA	0.0
42.900	18.000	0.0	N.A.	72.774	63.765	9.0090	NA	0.0
42.900	20.000	60.500	N.A.	72.774	63.765	9.0090	NA	0.0
39.750	20.000	76.250	N.A.	135.77	94.667	41.107	NA	129.23
39.250	20.000	78.750	N.A.	145.77	99.572	46.202	NA	152.48
38.750	20.000	81.250	N.A.	155.77	104.48	51.298	NA	176.48
38.250	20.000	83.750	N.A.	165.77	109.38	56.393	NA	201.23
37.750	20.000	86.250	N.A.	175.77	114.29	61.487	NA	226.73
37.250	20.000	88.750	N.A.	185.77	119.19	66.582	NA	252.98
36.750	20.000	91.250	N.A.	195.77	124.10	71.677	NA	279.98
36.250	20.000	93.750	N.A.	205.77	129.00	76.772	NA	307.73
35.750	20.000	96.250	N.A.	215.77	133.91	81.868	NA	336.23
35.250	20.000	98.750	N.A.	225.77	138.81	86.963	NA	365.48
35.000	20.000	100.00	N.A.	230.77	141.26	89.510	NA	380.39
35.000	20.000	100.00	N.A.	230.77	141.26	89.510	NA	380.39
34.750	20.000	102.50	N.A.	235.77	143.72	92.058	NA	395.57
34.250	20.000	107.50	N.A.	245.77	148.62	97.152	NA	427.07
33.750	20.000	112.50	N.A.	255.77	153.53	102.25	NA	460.07
33.250	20.000	117.50	N.A.	265.77	158.43	107.34	NA	494.57
32.750	20.000	122.50	N.A.	275.77	163.34	112.44	NA	530.57
32.250	20.000	127.50	N.A.	285.77	168.24	117.53	NA	568.07
31.750	20.000	132.50	N.A.	295.77	173.15	122.63	NA	607.07
31.250	20.000	137.50	N.A.	305.77	178.05	127.72	NA	647.57
30.750	20.000	142.50	N.A.	315.77	182.96	132.82	NA	689.57
30.250	20.000	147.50	N.A.	325.77	187.86	137.91	NA	733.07
29.750	20.000	152.50	N.A.	335.77	192.77	143.01	NA	778.07
29.250	20.000	157.50	N.A.	345.77	197.67	148.10	NA	824.57
28.750	20.000	162.50	N.A.	355.77	202.58	153.20	NA	872.57
28.250	20.000	167.50	N.A.	365.77	207.48	158.29	NA	922.07
27.750	20.000	172.50	N.A.	375.77	212.39	163.39	NA	973.07
27.250	20.000	177.50	N.A.	385.77	217.29	168.48	NA	1025.6
26.750	20.000	182.50	N.A.	395.77	222.20	173.58	NA	1079.6
26.250	20.000	187.50	N.A.	405.77	227.10	178.67	NA	1135.1
25.750	20.000	192.50	N.A.	415.77	232.01	183.77	NA	1192.1
25.250	20.000	197.50	N.A.	425.77	236.91	188.86	NA	1250.6
24.750	20.000	202.50	N.A.	435.77	241.82	193.96	NA	1310.6
24.250	20.000	207.50	N.A.	445.77	246.72	199.05	NA	1372.1
23.750	20.000	212.50	N.A.	455.77	251.63	204.15	NA	1435.1

* Effective horizontal stress not calculated for "Total Stress" materials and for Beta Method.

Cross-section 1 results:

Uniform pile with top shaft diameter = 0.45 m

Results - Compression

Soil Profile 1: Soil Profile 1

Level	Pile length	Ultimate base	Cumulative external	Negative skin	Net ultimate	Design resistance ultimate	Combination with least	Factored load*
-------	-------------	---------------	---------------------	---------------	--------------	----------------------------	------------------------	----------------

Hampstead - 24-26 Redington Gardens
 450mm dia pile 42.9mAD discounted
 vertical capacity

Job No.	Sheet No.	Rev.
21495	C1	
Drg. Ref.		
Made by DBS	Date	Checked

capacity		Friction			friction resistance		resistance		
[mOD]	[m]	(Q _b) [kN]	(Q _g) [kN]	(Q _{nsf}) [kN]	DA1-C1 [kN]	DA1-C2 [kN]	#	DA1-C1 [kN]	DA1-C2 [kN]
39.750	10.000	109.14	182.69	0.0	291.84	208.45	120.54	2 0.0(C)	0.0(C)
39.250	10.500	112.72	215.56	0.0	328.28	234.49	136.49	2 0.0(C)	0.0(C)
38.750	11.000	116.30	249.49	0.0	365.79	261.28	152.92	2 0.0(C)	0.0(C)
38.250	11.500	119.88	284.48	0.0	404.36	288.83	169.81	2 0.0(C)	0.0(C)
37.750	12.000	123.46	320.53	0.0	443.99	317.13	187.19	2 0.0(C)	0.0(C)
37.250	12.500	127.04	357.64	0.0	484.68	346.20	205.03	2 0.0(C)	0.0(C)
36.750	13.000	130.61	395.81	0.0	526.42	376.02	223.35	2 0.0(C)	0.0(C)
36.250	13.500	134.19	435.04	0.0	569.23	406.60	242.14	2 0.0(C)	0.0(C)
35.750	14.000	137.77	475.33	0.0	613.10	437.93	261.41	2 0.0(C)	0.0(C)
35.250	14.500	141.35	516.68	0.0	658.03	470.02	281.14	2 0.0(C)	0.0(C)
34.750	15.000	146.72	559.23	0.0	705.94	504.25	302.05	2 0.0(C)	0.0(C)
34.250	15.500	153.87	603.76	0.0	757.63	541.17	324.49	2 0.0(C)	0.0(C)
33.750	16.000	161.03	650.41	0.0	811.44	579.60	347.87	2 0.0(C)	0.0(C)
33.250	16.500	168.19	699.19	0.0	867.37	619.55	372.20	2 0.0(C)	0.0(C)
32.750	17.000	175.35	750.08	0.0	925.42	661.02	397.48	2 0.0(C)	0.0(C)
32.250	17.500	182.50	803.09	0.0	985.60	704.00	423.70	2 0.0(C)	0.0(C)
31.750	18.000	189.66	858.23	0.0	1047.9	748.49	450.87	2 0.0(C)	0.0(C)
31.250	18.500	196.82	915.48	0.0	1112.3	794.50	478.99	2 0.0(C)	0.0(C)
30.750	19.000	203.97	974.86	0.0	1178.8	842.02	508.05	2 0.0(C)	0.0(C)
30.250	19.500	211.13	1036.4	0.0	1247.5	891.06	538.06	2 0.0(C)	0.0(C)
29.750	20.000	218.29	1100.0	0.0	1318.3	941.61	569.02	2 0.0(C)	0.0(C)
29.250	20.500	225.44	1165.7	0.0	1391.2	993.68	600.92	2 0.0(C)	0.0(C)
28.750	21.000	232.60	1233.6	0.0	1466.2	1047.3	633.77	2 0.0(C)	0.0(C)
28.250	21.500	239.76	1303.5	0.0	1543.3	1102.4	667.57	2 0.0(C)	0.0(C)
27.750	22.000	246.91	1375.6	0.0	1622.6	1159.0	702.31	2 0.0(C)	0.0(C)
27.250	22.500	254.07	1449.9	0.0	1703.9	1217.1	738.00	2 0.0(C)	0.0(C)
26.750	23.000	261.23	1526.2	0.0	1787.4	1276.7	774.64	2 0.0(C)	0.0(C)
26.250	23.500	268.39	1604.7	0.0	1873.1	1337.9	812.22	2 0.0(C)	0.0(C)
25.750	24.000	275.54	1685.3	0.0	1960.8	1400.6	850.75	2 0.0(C)	0.0(C)
25.250	24.500	282.70	1768.0	0.0	2050.7	1464.8	890.23	2 0.0(C)	0.0(C)
24.750	25.000	289.86	1852.8	0.0	2142.6	1530.5	930.65	2 0.0(C)	0.0(C)
24.250	25.500	297.01	1939.7	0.0	2236.7	1597.7	972.02	2 0.0(C)	0.0(C)
23.750	26.000	304.17	2028.8	0.0	2333.0	1666.4	1014.3	2 0.0(C)	0.0(C)

Limiting criteria :

1 : DA1 C1

2 : DA1 C2

*(C)-> Compression load, (T)-> Tension load

Note: Design resistance does not include any consideration of negative skin friction.

Nq Calculation Details

Soil Profile 1: Soil Profile 1 - Material Factor Set - 1

There are no pile toe levels in any drained material(with Berezantzev/Bolton option) in the given soil profile.

Soil Profile 1: Soil Profile 1 - Material Factor Set - 2

There are no pile toe levels in any drained material(with Berezantzev/Bolton option) in the given soil profile.

Results - Tension

Soil Profile 1: Soil Profile 1

Level	Pile length	Cumulative external Friction	Net ultimate resistance	Design resistance	Combination with least resistance	Factored load*
[mOD]	[m]	(Q _g) [kN]	DA1-C1 [kN]	DA1-C2 [kN]	#	DA1-C1 [kN]
39.750	10.000	182.69	182.69	130.49	2	N.A.
39.250	10.500	215.56	215.56	153.97	2	N.A.
38.750	11.000	249.49	249.49	178.21	2	N.A.
38.250	11.500	284.48	284.48	203.20	2	N.A.
37.750	12.000	320.53	320.53	228.95	2	N.A.
37.250	12.500	357.64	357.64	255.46	2	N.A.
36.750	13.000	395.81	395.81	282.72	2	N.A.
36.250	13.500	435.04	435.04	310.74	2	N.A.
35.750	14.000	475.33	475.33	339.52	2	N.A.

Hampstead - 24-26 Redington Gardens
 450mm dia pile 42.9mAD discounted
 vertical capacity

Job No.	Sheet No.	Rev.
21495	C1	
Drg. Ref.		
Made by	Date	Checked
DBS		

Level	Pile length	Cumulative external Friction	Net ultimate resistance	Design resistance	Combination with least resistance	Factored load*
35.250	14.500	516.68	516.68	369.06	184.53	2 N.A. N.A.
34.750	15.000	559.23	559.23	399.45	199.72	2 N.A. N.A.
34.250	15.500	603.76	603.76	431.26	215.63	2 N.A. N.A.
33.750	16.000	650.41	650.41	464.58	232.29	2 N.A. N.A.
33.250	16.500	699.19	699.19	499.42	249.71	2 N.A. N.A.
32.750	17.000	750.08	750.08	535.77	267.89	2 N.A. N.A.
32.250	17.500	803.09	803.09	573.64	286.82	2 N.A. N.A.
31.750	18.000	858.23	858.23	613.02	306.51	2 N.A. N.A.
31.250	18.500	915.48	915.48	653.92	326.96	2 N.A. N.A.
30.750	19.000	974.86	974.86	696.33	348.16	2 N.A. N.A.
30.250	19.500	1036.4	1036.4	740.25	370.13	2 N.A. N.A.
29.750	20.000	1100.0	1100.0	785.70	392.85	2 N.A. N.A.
29.250	20.500	1165.7	1165.7	832.65	416.33	2 N.A. N.A.
28.750	21.000	1233.6	1233.6	881.12	440.56	2 N.A. N.A.
28.250	21.500	1303.5	1303.5	931.11	465.55	2 N.A. N.A.
27.750	22.000	1375.6	1375.6	982.61	491.30	2 N.A. N.A.
27.250	22.500	1449.9	1449.9	1035.6	517.81	2 N.A. N.A.
26.750	23.000	1526.2	1526.2	1090.1	545.07	2 N.A. N.A.
26.250	23.500	1604.7	1604.7	1146.2	573.10	2 N.A. N.A.
25.750	24.000	1685.3	1685.3	1203.8	601.88	2 N.A. N.A.
25.250	24.500	1768.0	1768.0	1262.8	631.41	2 N.A. N.A.
24.750	25.000	1852.8	1852.8	1323.4	661.71	2 N.A. N.A.
24.250	25.500	1939.7	1939.7	1385.5	692.76	2 N.A. N.A.
23.750	26.000	2028.8	2028.8	1449.1	724.57	2 N.A. N.A.

Note - The weight of the pile has not been included in the factored load.

Limiting criteria :

1 : DA1 C1 [Shaft Tension]

2 : DA1 C2 [Shaft Tension]

*(C)-> Compression load, (T)-> Tension load

Note: Design resistance does not include any consideration of negative skin friction.

Job No.	Sheet No.	Rev.
21495	C2	
Drg. Ref.		
Made by DBS	Date	Checked

Notes

PPL = 49.75mAD

Analysis Options

Design approach: DA1(C1 + C2)
 Pile type: CFA
 Model factor: 1.40
 Partial factor on negative skin friction - Set A1: 1.00
 Partial factor on negative skin friction - Set A2: 1.00
 Serviceability verified by load tests (preliminary/working) carried out on more than 1% of constructed piles to loads not less than 1.5 times the representative load for which they are designed? No
 Resistance verified by a maintained load test taken to the calculated, unfactored, ultimate resistance? No
 Datum type: Elevation based
 Effective stress profile: Calculated

Pile Properties

Pile type: Solid
 Pile cross-section: Circular
 Under-ream: No
 Calculation profile: Range
 Minimum pile length: 14.000 m
 Maximum pile length: 30.000 m
 Increment size: 0.50000

Cross-section	Number of cross sections	Top Diameter [m]	Second Diameter location [m]	Second Diameter [m]	Third Diameter location [m]	Third Diameter [m]
Cross-section 1	1	0.45000				

Undrained Materials - General Data

No.	Material description	Bulk unit weight [kN/m ³]	Cu material factor	Top Cu [kPa]	Base Cu [kPa]
1	Discounted Soil	18.000	NA	0.0	0.0
2	London Clay	20.000	NA	56.500	100.00
3	London Clay 2	20.000	NA	100.00	250.00
4	London Clay 3	20.000	NA	250.00	250.00

Undrained Materials - Skin Friction Data

No.	Material description	Skin friction computation	Alpha	q _s Top [kPa]	q _s Base [kPa]	Spec. Value [kPa]	q _{s,lim}
1	Discounted Soil	Alpha specified	0.0	NA	NA	No	NA
2	London Clay	Alpha specified	0.60000	NA	NA	No	NA
3	London Clay 2	Alpha specified	0.60000	NA	NA	No	NA
4	London Clay 3	Alpha specified	0.60000	NA	NA	No	NA

Undrained Materials - End Bearing Data

No.	Material description	End bearing computation	Nc	q _b Top [kPa]	q _b Base [kPa]	Spec. Value [kPa]	q _{b,lim}

Hampstead - 24-26 Redington Gardens
 450mm dia pile 43.7mAD discounted
 vertical capacity

Job No.	Sheet No.	Rev.
21495	C2	
Drg. Ref.		
Made by DBS	Date	Checked

No.	Material description	End bearing computation	Nc	Q _b	Q _{b,lim}
				Top [kPa]	Base Spec. Value [kPa]
1	Discounted Soil	Nc specified	0.0	NA	NA No NA
2	London Clay	Nc specified	9.0000	NA	NA No NA
3	London Clay 2	Nc specified	9.0000	NA	NA No NA
4	London Clay 3	Nc specified	9.0000	NA	NA No NA

Undrained Materials - Material Factors (Code Based)

No.	Material description	Qs factors		Nc factors		Qb factors	
		M1	M2	M1	M2	M1	M2
1	Discounted Soil	N.A.	N.A.	1.0000	1.0000	N.A.	N.A.
2	London Clay	N.A.	N.A.	1.0000	1.0000	N.A.	N.A.
3	London Clay 2	N.A.	N.A.	1.0000	1.0000	N.A.	N.A.
4	London Clay 3	N.A.	N.A.	1.0000	1.0000	N.A.	N.A.

STAGE SPECIFIC DATA

Stage 0 : Initial Stage

Groundwater

No.	Level [m]	Pressure [kPa]	Unit weight of water [kN/m ³]
1	49.400	0.0	9.8100

Soil Profiles

Soil Profile 1: Soil Profile 1

No.	Level [mOD]	Material description	Contributes to negative skin friction
1	49.750	Air/Void	No
2	44.000	Discounted Soil	No
3	43.700	London Clay	No
4	35.000	London Clay 2	No
5	20.000	London Clay 3	No

Soil Profile - Groundwater Map

No.	Soil Profile	Groundwater
1	Soil Profile 1	Groundwater Profile 1

Stage specific warnings

- 1 - Stage 0 - The bottom most layer in Soil Profile 1 is assigned "Total stress" material. For this layer the cohesion is assumed to be constant at "Cu-Top", i.e cohesion specified at the top of this layer. The user specified value of cohesion at the bottom of this layer, "Cu-Bottom" is ignored. (Material Properties)

CAPACITY RESULTS

Partial Resistance Factors Used:

DA1 C1

Shaft resistance factor for set R1 (Compression):	1.00
Base resistance factor for set R1:	1.00
Shaft resistance factor for set R1 (Tension):	1.00

Hampstead - 24-26 Redington Gardens
 450mm dia pile 43.7mAD discounted
 vertical capacity

Job No.	Sheet No.	Rev.
21495	C2	
Drg. Ref.		
Made by	Date	Checked
DBS		

No.	Soil Profile	Groundwater
------------	---------------------	--------------------

DA1 C2

Shaft resistance factor for set R4 (Compression): 1.60
 Base resistance factor for set R4: 2.00
 Shaft resistance factor for set R4 (Tension): 2.00
 Model factor: 1.40

Stress Profiles

Soil Profile 1: Soil Profile 1

Level	Density	Undrained Cohesion	Nq	Total vertical stress	Porewater pressure	Effective vertical stress	Effective horizontal stress*	Cumulative skin friction per unit perimeter
[mOD]	[kN/m ³]	[kPa]		[kPa]	[kPa]	[kPa]	[kPa]	[kN/m]
49.750	0.0	0.0	0.0	0.0	0.0	0.0	NA	0.0
49.400	9.8100	0.0	0.0	0.0	0.0	0.0	NA	0.0
44.000	9.8100	0.0	0.0	52.974	52.974	0.0	NA	0.0
44.000	18.000	0.0	N.A.	52.974	52.974	0.0	NA	0.0
43.700	18.000	0.0	N.A.	58.374	55.917	2.4570	NA	0.0
43.700	20.000	56.500	N.A.	58.374	55.917	2.4570	NA	0.0
35.750	20.000	96.250	N.A.	217.37	133.91	83.467	NA	364.31
35.250	20.000	98.750	N.A.	227.37	138.81	88.563	NA	393.56
35.000	20.000	100.00	N.A.	232.37	141.26	91.110	NA	408.47
35.000	20.000	100.00	N.A.	232.37	141.26	91.110	NA	408.47
34.750	20.000	102.50	N.A.	237.37	143.72	93.658	NA	423.65
34.250	20.000	107.50	N.A.	247.37	148.62	98.753	NA	455.15
33.750	20.000	112.50	N.A.	257.37	153.53	103.85	NA	488.15
33.250	20.000	117.50	N.A.	267.37	158.43	108.94	NA	522.65
32.750	20.000	122.50	N.A.	277.37	163.34	114.04	NA	558.65
32.250	20.000	127.50	N.A.	287.37	168.24	119.13	NA	596.15
31.750	20.000	132.50	N.A.	297.37	173.15	124.23	NA	635.15
31.250	20.000	137.50	N.A.	307.37	178.05	129.32	NA	675.65
30.750	20.000	142.50	N.A.	317.37	182.96	134.42	NA	717.65
30.250	20.000	147.50	N.A.	327.37	187.86	139.51	NA	761.15
29.750	20.000	152.50	N.A.	337.37	192.77	144.61	NA	806.15
29.250	20.000	157.50	N.A.	347.37	197.67	149.70	NA	852.65
28.750	20.000	162.50	N.A.	357.37	202.58	154.80	NA	900.65
28.250	20.000	167.50	N.A.	367.37	207.48	159.89	NA	950.15
27.750	20.000	172.50	N.A.	377.37	212.39	164.99	NA	1001.2
27.250	20.000	177.50	N.A.	387.37	217.29	170.08	NA	1053.7
26.750	20.000	182.50	N.A.	397.37	222.20	175.18	NA	1107.7
26.250	20.000	187.50	N.A.	407.37	227.10	180.27	NA	1163.2
25.750	20.000	192.50	N.A.	417.37	232.01	185.37	NA	1220.2
25.250	20.000	197.50	N.A.	427.37	236.91	190.46	NA	1278.7
24.750	20.000	202.50	N.A.	437.37	241.82	195.56	NA	1338.7
24.250	20.000	207.50	N.A.	447.37	246.72	200.65	NA	1400.2
23.750	20.000	212.50	N.A.	457.37	251.63	205.75	NA	1463.2
23.250	20.000	217.50	N.A.	467.37	256.53	210.84	NA	1527.7
22.750	20.000	222.50	N.A.	477.37	261.44	215.94	NA	1593.7
22.250	20.000	227.50	N.A.	487.37	266.34	221.03	NA	1661.2
21.750	20.000	232.50	N.A.	497.37	271.25	226.13	NA	1730.2
21.250	20.000	237.50	N.A.	507.37	276.15	231.22	NA	1800.7
20.750	20.000	242.50	N.A.	517.37	281.06	236.32	NA	1872.7
20.250	20.000	247.50	N.A.	527.37	285.96	241.41	NA	1946.2
20.000	20.000	250.00	N.A.	532.37	288.41	243.96	NA	1983.5
20.000	20.000	250.00	N.A.	532.37	288.41	243.96	NA	1983.5
19.750	20.000	250.00	N.A.	537.37	290.87	246.51	NA	2021.0

* Effective horizontal stress not calculated for "Total Stress" materials and for Beta Method.

Cross-section 1 results:

Uniform pile with top shaft diameter = 0.45 m

Results - Compression

Soil Profile 1: Soil Profile 1

Hampstead - 24-26 Redington Gardens
 450mm dia pile 43.7mAD discounted
 vertical capacity

Job No.	Sheet No.	Rev.
21495	C2	
Drg. Ref.		
Made by DBS	Date	Checked

Level	Pile length	Ultimate base capacity	Cumulative external Friction	Negative skin friction	Net ultimate resistance	Design resistance	Combination with least resistance	Factored load*	
		(Q _b)	(Q _g)	(Q _{nsf})		DA1-C1	DA1-C2	#	
[mOD]	[m]	[kN]	[kN]	[kN]	[kN]	[kN]	[kN]	DA1-C1	DA1-C2
35.750	14.000	137.77	515.03	0.0	652.80	466.29	279.13	2	0.0(C) 0.0(C)
35.250	14.500	141.35	556.38	0.0	697.73	498.38	298.87	2	0.0(C) 0.0(C)
34.750	15.000	146.72	598.92	0.0	745.64	532.60	319.78	2	0.0(C) 0.0(C)
34.250	15.500	153.87	643.46	0.0	797.33	569.52	342.21	2	0.0(C) 0.0(C)
33.750	16.000	161.03	690.11	0.0	851.14	607.96	365.60	2	0.0(C) 0.0(C)
33.250	16.500	168.19	738.88	0.0	907.07	647.91	389.93	2	0.0(C) 0.0(C)
32.750	17.000	175.35	789.78	0.0	965.12	689.37	415.20	2	0.0(C) 0.0(C)
32.250	17.500	182.50	842.79	0.0	1025.3	732.35	441.43	2	0.0(C) 0.0(C)
31.750	18.000	189.66	897.93	0.0	1087.6	776.85	468.60	2	0.0(C) 0.0(C)
31.250	18.500	196.82	955.18	0.0	1152.0	822.86	496.71	2	0.0(C) 0.0(C)
30.750	19.000	203.97	1014.6	0.0	1218.5	870.38	525.77	2	0.0(C) 0.0(C)
30.250	19.500	211.13	1076.1	0.0	1287.2	919.42	555.78	2	0.0(C) 0.0(C)
29.750	20.000	218.29	1139.7	0.0	1358.0	969.97	586.74	2	0.0(C) 0.0(C)
29.250	20.500	225.44	1205.4	0.0	1430.9	1022.0	618.64	2	0.0(C) 0.0(C)
28.750	21.000	232.60	1273.3	0.0	1505.9	1075.6	651.49	2	0.0(C) 0.0(C)
28.250	21.500	239.76	1343.2	0.0	1583.0	1130.7	685.29	2	0.0(C) 0.0(C)
27.750	22.000	246.91	1415.3	0.0	1662.3	1187.3	720.03	2	0.0(C) 0.0(C)
27.250	22.500	254.07	1489.6	0.0	1743.6	1245.5	755.72	2	0.0(C) 0.0(C)
26.750	23.000	261.23	1565.9	0.0	1827.1	1305.1	792.36	2	0.0(C) 0.0(C)
26.250	23.500	268.39	1644.4	0.0	1912.8	1366.3	829.94	2	0.0(C) 0.0(C)
25.750	24.000	275.54	1724.9	0.0	2000.5	1428.9	868.47	2	0.0(C) 0.0(C)
25.250	24.500	282.70	1807.7	0.0	2090.4	1493.1	907.95	2	0.0(C) 0.0(C)
24.750	25.000	289.86	1892.5	0.0	2182.3	1558.8	948.38	2	0.0(C) 0.0(C)
24.250	25.500	297.01	1979.4	0.0	2276.4	1626.0	989.75	2	0.0(C) 0.0(C)
23.750	26.000	304.17	2068.5	0.0	2372.7	1694.8	1032.1	2	0.0(C) 0.0(C)
23.250	26.500	311.33	2159.7	0.0	2471.0	1765.0	1075.3	2	0.0(C) 0.0(C)
22.750	27.000	318.48	2253.0	0.0	2571.5	1836.8	1119.5	2	0.0(C) 0.0(C)
22.250	27.500	325.64	2348.4	0.0	2674.0	1910.0	1164.7	2	0.0(C) 0.0(C)
21.750	28.000	332.80	2445.9	0.0	2778.7	1984.8	1210.8	2	0.0(C) 0.0(C)
21.250	28.500	339.95	2545.6	0.0	2885.6	2061.1	1257.8	2	0.0(C) 0.0(C)
20.750	29.000	347.11	2647.4	0.0	2994.5	2138.9	1305.8	2	0.0(C) 0.0(C)
20.250	29.500	354.27	2751.3	0.0	3105.6	2218.3	1354.8	2	0.0(C) 0.0(C)
19.750	30.000	357.85	2857.1	0.0	3214.9	2296.4	1403.3	2	0.0(C) 0.0(C)

Limiting criteria :

1 : DA1 C1

2 : DA1 C2

*(C)-> Compression load, (T)-> Tension load

Note: Design resistance does not include any consideration of negative skin friction.

Nq Calculation Details

Soil Profile 1: Soil Profile 1 - Material Factor Set - 1

There are no pile toe levels in any drained material(with Berezantzev/Bolton option) in the given soil profile.

Soil Profile 1: Soil Profile 1 - Material Factor Set - 2

There are no pile toe levels in any drained material(with Berezantzev/Bolton option) in the given soil profile.

Results - Tension

Soil Profile 1: Soil Profile 1

Level	Pile length	Cumulative external Friction	Net ultimate resistance	Design resistance	Combination with least resistance	Factored load*	
		(Q _g)		DA1-C1	DA1-C2	#	
[mOD]	[m]	[kN]	[kN]	[kN]	[kN]	DA1-C1	DA1-C2
35.750	14.000	515.03	515.03	367.88	183.94	2	N.A. N.A.
35.250	14.500	556.38	556.38	397.41	198.71	2	N.A. N.A.
34.750	15.000	598.92	598.92	427.80	213.90	2	N.A. N.A.
34.250	15.500	643.46	643.46	459.61	229.81	2	N.A. N.A.
33.750	16.000	690.11	690.11	492.94	246.47	2	N.A. N.A.
33.250	16.500	738.88	738.88	527.77	263.89	2	N.A. N.A.
32.750	17.000	789.78	789.78	564.13	282.06	2	N.A. N.A.

Hampstead - 24-26 Redington Gardens
 450mm dia pile 43.7mAD discounted
 vertical capacity

Job No.	Sheet No.	Rev.
21495	C2	
Drg. Ref.		
Made by DBS	Date	Checked

Level	Pile length	Cumulative external Friction	Net ultimate resistance	Design resistance	Resistance	Combination with least resistance	Factored load*
32.250	17.500	842.79	842.79	601.99	301.00	2	N.A. N.A.
31.750	18.000	897.93	897.93	641.38	320.69	2	N.A. N.A.
31.250	18.500	955.18	955.18	682.27	341.14	2	N.A. N.A.
30.750	19.000	1014.6	1014.6	724.68	362.34	2	N.A. N.A.
30.250	19.500	1076.1	1076.1	768.61	384.31	2	N.A. N.A.
29.750	20.000	1139.7	1139.7	814.05	407.03	2	N.A. N.A.
29.250	20.500	1205.4	1205.4	861.01	430.50	2	N.A. N.A.
28.750	21.000	1273.3	1273.3	909.48	454.74	2	N.A. N.A.
28.250	21.500	1343.2	1343.2	959.46	479.73	2	N.A. N.A.
27.750	22.000	1415.3	1415.3	1011.0	505.48	2	N.A. N.A.
27.250	22.500	1489.6	1489.6	1064.0	531.99	2	N.A. N.A.
26.750	23.000	1565.9	1565.9	1118.5	559.25	2	N.A. N.A.
26.250	23.500	1644.4	1644.4	1174.5	587.27	2	N.A. N.A.
25.750	24.000	1724.9	1724.9	1232.1	616.05	2	N.A. N.A.
25.250	24.500	1807.7	1807.7	1291.2	645.59	2	N.A. N.A.
24.750	25.000	1892.5	1892.5	1351.8	675.88	2	N.A. N.A.
24.250	25.500	1979.4	1979.4	1413.9	706.94	2	N.A. N.A.
23.750	26.000	2068.5	2068.5	1477.5	738.74	2	N.A. N.A.
23.250	26.500	2159.7	2159.7	1542.6	771.31	2	N.A. N.A.
22.750	27.000	2253.0	2253.0	1609.3	804.63	2	N.A. N.A.
22.250	27.500	2348.4	2348.4	1677.4	838.71	2	N.A. N.A.
21.750	28.000	2445.9	2445.9	1747.1	873.55	2	N.A. N.A.
21.250	28.500	2545.6	2545.6	1818.3	909.15	2	N.A. N.A.
20.750	29.000	2647.4	2647.4	1891.0	945.50	2	N.A. N.A.
20.250	29.500	2751.3	2751.3	1965.2	982.61	2	N.A. N.A.
19.750	30.000	2857.1	2857.1	2040.8	1020.4	2	N.A. N.A.

Note - The weight of the pile has not been included in the factored load.

Limiting criteria :

1 : DA1 C1 [Shaft Tension]

2 : DA1 C2 [Shaft Tension]

*(C)-> Compression load, (T)-> Tension load

Note: Design resistance does not include any consideration of negative skin friction.

Job No.	Sheet No.	Rev.
21495	C3	
Drg. Ref.		
Made by DBS	Date	Checked

Notes

PPL = 49.75mAD

Analysis Options

Design approach: DA1 (C1 + C2)
 Pile type: CFA
 Model factor: 1.40
 Partial factor on negative skin friction - Set A1: 1.00
 Partial factor on negative skin friction - Set A2: 1.00
 Serviceability verified by load tests (preliminary/working) carried out on more than 1% of constructed piles to loads not less than 1.5 times the representative load for which they are designed? No
 Resistance verified by a maintained load test taken to the calculated, unfactored, ultimate resistance? No
 Datum type: Elevation based
 Effective stress profile: Calculated

Pile Properties

Pile type: Solid
 Pile cross-section: Circular
 Under-ream: No
 Calculation profile: Range
 Minimum pile length: 9.0000 m
 Maximum pile length: 18.000 m
 Increment size: 0.50000

Cross-section	Number of cross sections	Top Diameter [m]	Second Diameter location [m]	Second Diameter [m]	Third Diameter location [m]	Third Diameter [m]
Cross-section 1	1	0.45000				

Undrained Materials - General Data

No.	Material description	Bulk unit weight [kN/m ³]	Cu material factor	Top Cu [kPa]	Base Cu [kPa]
1	Discounted Soil	18.000	NA	0.0	0.0
2	London Clay	20.000	NA	57.000	100.00
3	London Clay 2	20.000	NA	100.00	250.00
4	London Clay 3	20.000	NA	250.00	250.00

Undrained Materials - Skin Friction Data

No.	Material description	Skin friction computation	Alpha	q _s Top [kPa]	q _s Base [kPa]	Spec. Value [kPa]	q _{s,lim}
1	Discounted Soil	Alpha specified	0.0	NA	NA	No	NA
2	London Clay	Alpha specified	0.60000	NA	NA	No	NA
3	London Clay 2	Alpha specified	0.60000	NA	NA	No	NA
4	London Clay 3	Alpha specified	0.60000	NA	NA	No	NA

Undrained Materials - End Bearing Data

No.	Material description	End bearing computation	Nc	q _b Top [kPa]	q _b Base [kPa]	Spec. Value [kPa]	q _{b,lim}

Hampstead - 24-26 Redington Gardens
 450mm dia pile 43.6mAD discounted
 vertical capacity

Job No.	Sheet No.	Rev.
21495	C3	
Drg. Ref.		
Made by DBS	Date	Checked

No.	Material description	End bearing computation	Nc	Q _b	Q _{b,lim}
				Top [kPa]	Base Spec. Value [kPa]
1	Discounted Soil	Nc specified	0.0	NA	NA No NA
2	London Clay	Nc specified	9.0000	NA	NA No NA
3	London Clay 2	Nc specified	9.0000	NA	NA No NA
4	London Clay 3	Nc specified	9.0000	NA	NA No NA

Undrained Materials - Material Factors (Code Based)

No.	Material description	Qs factors		Nc factors		Qb factors	
		M1	M2	M1	M2	M1	M2
1	Discounted Soil	N.A.	N.A.	1.0000	1.0000	N.A.	N.A.
2	London Clay	N.A.	N.A.	1.0000	1.0000	N.A.	N.A.
3	London Clay 2	N.A.	N.A.	1.0000	1.0000	N.A.	N.A.
4	London Clay 3	N.A.	N.A.	1.0000	1.0000	N.A.	N.A.

STAGE SPECIFIC DATA

Stage 0 : Initial Stage

Groundwater

No.	Level [m]	Pressure [kPa]	Unit weight of water [kN/m ³]
1	49.400	0.0	9.8100

Soil Profiles

Soil Profile 1: Soil Profile 1

No.	Level [mOD]	Material description	Contributes to negative skin friction
1	49.750	Air/Void	No
2	44.000	Discounted Soil	No
3	43.600	London Clay	No
4	35.000	London Clay 2	No
5	20.000	London Clay 3	No

Soil Profile - Groundwater Map

No.	Soil Profile	Groundwater
1	Soil Profile 1	Groundwater Profile 1

Stage specific warnings

- 1 - Stage 0 - The bottom most layer in Soil Profile 1 is assigned "Total stress" material. For this layer the cohesion is assumed to be constant at "Cu-Top", i.e cohesion specified at the top of this layer. The user specified value of cohesion at the bottom of this layer, "Cu-Bottom" is ignored. (Material Properties)

CAPACITY RESULTS

Partial Resistance Factors Used:

DA1 C1

Shaft resistance factor for set R1 (Compression):	1.00
Base resistance factor for set R1:	1.00
Shaft resistance factor for set R1 (Tension):	1.00

Hampstead - 24-26 Redington Gardens
 450mm dia pile 43.6mAD discounted
 vertical capacity

Job No.	Sheet No.	Rev.
21495	C3	
Drg. Ref.		
Made by DBS	Date	Checked

No.	Soil Profile	Groundwater
-----	--------------	-------------

DA1 C2

Shaft resistance factor for set R4 (Compression): 1.60
 Base resistance factor for set R4: 2.00
 Shaft resistance factor for set R4 (Tension): 2.00
 Model factor: 1.40

Stress Profiles

Soil Profile 1: Soil Profile 1

Level	Density	Undrained Cohesion	Nq	Total vertical stress	Porewater pressure	Effective vertical stress	Effective horizontal stress*	Cumulative skin friction per unit perimeter
[mOD]	[kN/m³]	[kPa]		[kPa]	[kPa]	[kPa]	[kPa]	[kN/m]
49.750	0.0	0.0	0.0	0.0	0.0	0.0	NA	0.0
49.400	9.8100	0.0	0.0	0.0	0.0	0.0	NA	0.0
44.000	9.8100	0.0	0.0	52.974	52.974	0.0	NA	0.0
44.000	18.000	0.0	N.A.	52.974	52.974	0.0	NA	0.0
43.600	18.000	0.0	N.A.	60.174	56.898	3.2760	NA	0.0
43.600	20.000	57.000	N.A.	60.174	56.898	3.2760	NA	0.0
40.750	20.000	71.250	N.A.	117.17	84.857	32.318	NA	109.65
40.250	20.000	73.750	N.A.	127.17	89.762	37.412	NA	131.40
39.750	20.000	76.250	N.A.	137.17	94.667	42.507	NA	153.90
39.250	20.000	78.750	N.A.	147.17	99.572	47.603	NA	177.15
38.750	20.000	81.250	N.A.	157.17	104.48	52.697	NA	201.15
38.250	20.000	83.750	N.A.	167.17	109.38	57.792	NA	225.90
37.750	20.000	86.250	N.A.	177.17	114.29	62.888	NA	251.40
37.250	20.000	88.750	N.A.	187.17	119.19	67.982	NA	277.65
36.750	20.000	91.250	N.A.	197.17	124.10	73.077	NA	304.65
36.250	20.000	93.750	N.A.	207.17	129.00	78.173	NA	332.40
35.750	20.000	96.250	N.A.	217.17	133.91	83.268	NA	360.90
35.250	20.000	98.750	N.A.	227.17	138.81	88.363	NA	390.15
35.000	20.000	100.00	N.A.	232.17	141.26	90.910	NA	405.06
35.000	20.000	100.00	N.A.	232.17	141.26	90.910	NA	405.06
34.750	20.000	102.50	N.A.	237.17	143.72	93.457	NA	420.25
34.250	20.000	107.50	N.A.	247.17	148.62	98.552	NA	451.75
33.750	20.000	112.50	N.A.	257.17	153.53	103.65	NA	484.75
33.250	20.000	117.50	N.A.	267.17	158.43	108.74	NA	519.25
32.750	20.000	122.50	N.A.	277.17	163.34	113.84	NA	555.25
32.250	20.000	127.50	N.A.	287.17	168.24	118.93	NA	592.75
31.750	20.000	132.50	N.A.	297.17	173.15	124.03	NA	631.75

* Effective horizontal stress not calculated for "Total Stress" materials and for Beta Method.

Cross-section 1 results:

Uniform pile with top shaft diameter = 0.45 m

Results - Compression

Soil Profile 1: Soil Profile 1

Level	Pile length	Ultimate base capacity	Cumulative external Friction	Negative skin friction	Net ultimate resistance	Design resistance	Design resistance	Combination with least resistance	Factored load*
		(Q _b)	(Q _s)	(Q _{nsf})		DA1-C1	DA1-C2		#
[mOD]	[m]	[kN]	[kN]	[kN]	[kN]	[kN]	[kN]	[kN]	[kN]
40.750	9.0000	101.99	155.02	0.0	257.01	183.58	105.63	2 0.0(C)	0.0(C)
40.250	9.5000	105.56	185.77	0.0	291.33	208.09	120.63	2 0.0(C)	0.0(C)
39.750	10.000	109.14	217.58	0.0	326.72	233.37	136.11	2 0.0(C)	0.0(C)
39.250	10.500	112.72	250.45	0.0	363.17	259.40	152.06	2 0.0(C)	0.0(C)
38.750	11.000	116.30	284.37	0.0	400.67	286.20	168.49	2 0.0(C)	0.0(C)
38.250	11.500	119.88	319.36	0.0	439.24	313.74	185.39	2 0.0(C)	0.0(C)
37.750	12.000	123.46	355.41	0.0	478.87	342.05	202.76	2 0.0(C)	0.0(C)
37.250	12.500	127.04	392.52	0.0	519.56	371.11	220.60	2 0.0(C)	0.0(C)
36.750	13.000	130.61	430.69	0.0	561.31	400.93	238.92	2 0.0(C)	0.0(C)

Hampstead - 24-26 Redington Gardens
 450mm dia pile 43.6mAD discounted
 vertical capacity

Job No.	Sheet No.	Rev.
21495	C3	
Drg. Ref.		
Made by	Date	Checked
DBS		

Level	Pile length	Ultimate base capacity	Cumulative external Friction	Negative skin friction	Net ultimate resistance	Design resistance	Combination with least resistance	Factored load*
36.250	13.500	134.19	469.92	0.0	604.12	431.51	257.71	2 0.0(C) 0.0(C)
35.750	14.000	137.77	510.22	0.0	647.99	462.85	276.98	2 0.0(C) 0.0(C)
35.250	14.500	141.35	551.57	0.0	692.92	494.94	296.72	2 0.0(C) 0.0(C)
34.750	15.000	146.72	594.11	0.0	740.83	529.16	317.63	2 0.0(C) 0.0(C)
34.250	15.500	153.87	638.64	0.0	792.52	566.08	340.06	2 0.0(C) 0.0(C)
33.750	16.000	161.03	685.30	0.0	846.33	604.52	363.45	2 0.0(C) 0.0(C)
33.250	16.500	168.19	734.07	0.0	902.26	644.47	387.78	2 0.0(C) 0.0(C)
32.750	17.000	175.35	784.96	0.0	960.31	685.93	413.05	2 0.0(C) 0.0(C)
32.250	17.500	182.50	837.98	0.0	1020.5	728.91	439.28	2 0.0(C) 0.0(C)
31.750	18.000	189.66	893.11	0.0	1082.8	773.41	466.45	2 0.0(C) 0.0(C)

Limiting criteria :

1 : DA1 C1

2 : DA1 C2

*(C)-> Compression load, (T)-> Tension load

Note: Design resistance does not include any consideration of negative skin friction.

Nq Calculation Details

Soil Profile 1: Soil Profile 1 - Material Factor Set - 1

There are no pile toe levels in any drained material(with Berezantzev/Bolton option) in the given soil profile.

Soil Profile 1: Soil Profile 1 - Material Factor Set - 2

There are no pile toe levels in any drained material(with Berezantzev/Bolton option) in the given soil profile.

Results - Tension

Soil Profile 1: Soil Profile 1

Level	Pile length	Cumulative external Friction	Net ultimate resistance	Design resistance	Combination with least resistance	Factored load*
		(Q _s)	DA1-C1	DA1-C2	#	DA1-C1 DA1-C2
[mOD]	[m]	[kN]	[kN]	[kN]		[kN] [kN]
40.750	9.0000	155.02	155.02	110.73	55.364	2 N.A. N.A.
40.250	9.5000	185.77	185.77	132.69	66.346	2 N.A. N.A.
39.750	10.000	217.58	217.58	155.41	77.706	2 N.A. N.A.
39.250	10.500	250.45	250.45	178.89	89.445	2 N.A. N.A.
38.750	11.000	284.37	284.37	203.12	101.56	2 N.A. N.A.
38.250	11.500	319.36	319.36	228.12	114.06	2 N.A. N.A.
37.750	12.000	355.41	355.41	253.87	126.93	2 N.A. N.A.
37.250	12.500	392.52	392.52	280.37	140.19	2 N.A. N.A.
36.750	13.000	430.69	430.69	307.64	153.82	2 N.A. N.A.
36.250	13.500	469.92	469.92	335.66	167.83	2 N.A. N.A.
35.750	14.000	510.22	510.22	364.44	182.22	2 N.A. N.A.
35.250	14.500	551.57	551.57	393.98	196.99	2 N.A. N.A.
34.750	15.000	594.11	594.11	424.36	212.18	2 N.A. N.A.
34.250	15.500	638.64	638.64	456.17	228.09	2 N.A. N.A.
33.750	16.000	685.30	685.30	489.50	244.75	2 N.A. N.A.
33.250	16.500	734.07	734.07	524.33	262.17	2 N.A. N.A.
32.750	17.000	784.96	784.96	560.69	280.34	2 N.A. N.A.
32.250	17.500	837.98	837.98	598.55	299.28	2 N.A. N.A.
31.750	18.000	893.11	893.11	637.94	318.97	2 N.A. N.A.

Note - The weight of the pile has not been included in the factored load.

Limiting criteria :

1 : DA1 C1 [Shaft Tension]

2 : DA1 C2 [Shaft Tension]

*(C)-> Compression load, (T)-> Tension load

Note: Design resistance does not include any consideration of negative skin friction.



APPENDIX D

Ref No	Description
D1-A	Results of "ALP" analysis for 450mm diameter bearing piles based on cut-off level of 43.307mAD and horizontal load of 60kN, DA1-1 analysis.
D1-B	Results of "ALP" analysis for 450mm diameter bearing piles based on cut-off level of 43.307mAD and horizontal load of 60kN, DA1-2 analysis.
D2-A	Results of "ALP" analysis for 450mm diameter bearing piles based on cut-off level of 43.307mAD and horizontal load of 50kN, DA1-1 analysis.
D2-B	Results of "ALP" analysis for 450mm diameter bearing piles based on cut-off level of 43.307mAD and horizontal load of 50kN, DA1-2 analysis.
D3-A	Results of "ALP" analysis for 450mm diameter bearing piles based on cut-off level of 43.48 & 43.805mAD and horizontal load of 25kN, DA1-1 analysis.
D3-B	Results of "ALP" analysis for 450mm diameter bearing piles based on cut-off level of 43.48 & 43.805mAD and horizontal load of 25kN, DA1-2 analysis.

Hampstead - 24-26 Redington Gardens
 450mm diameter
 moment condition - 60kN (SLS) Horizontal

Job No.	Sheet No.	Rev.
21495	D1-A	
Drg. Ref.		
Made by DBS	Date	Checked

Notes

Case D1-A

General Data

Number of increments = 1
 Increment applied loads only

Convergence Control

Maximum number of iterations = 300
 Maximum displacement error [mm] = 0.0010000
 Maximum pressure error [kN/m²] = 0.10000
 Damping coefficient = 1.0000
 Maximum incremental deflection [m] = 2.0000

Soil Data

Elastic-plastic soils
 Factor on soil E value: 0.8000

No.	Level	E	Unit	Phi	Factored K _q	Factored K _c	c(top)	dc/dz
	[m]	[kN/m ²]	[kN/m ³]	[deg]			[kN/m ²]	[kN/m ² /m]
1	43.299999	29250.	20.000	25.000	-	-	0.0	0.0
2	35.000000	50000.	20.000	25.000	-	-	0.0	0.0
3	30.000000	75000.	20.000	25.000	-	-	0.0	0.0

Calculated K_q and K_c Values

Node	Z/D	K _q	K _c
1	0.0	3.2869	5.6339
2	0.54209	3.7651	10.054
3	1.0842	4.1788	13.374
4	1.6263	4.5401	15.959
5	2.1684	4.8585	18.030
6	2.7104	5.1411	19.725
7	3.2525	5.3937	21.139
8	3.7946	5.6207	22.336
9	4.3367	5.8260	23.362
10	4.8788	6.0124	24.252
11	5.4209	6.1825	25.031
12	5.9630	6.3384	25.718
13	6.5051	6.4816	26.330
14	7.0471	6.6138	26.877
15	7.5892	6.7361	27.369
16	8.1313	6.8496	27.815
17	8.6734	6.9552	28.220
18	9.2155	7.0537	28.590
19	9.7576	7.1459	28.929
20	10.300	7.2322	29.242
21	10.842	7.3133	29.530
22	11.384	7.3896	29.797
23	11.926	7.4615	30.044
24	12.468	7.5294	30.275
25	13.010	7.5936	30.491
26	13.552	7.6545	30.692
27	14.094	7.7121	30.881
28	14.636	7.7669	31.058
29	15.178	7.8190	31.226
30	15.721	7.8686	31.383
31	16.263	7.9159	31.532
32	16.805	7.9610	31.673
33	17.347	8.0042	31.806
34	17.889	8.0454	31.933
35	18.259	8.0725	32.015
36	18.630	8.0989	32.095
37	19.000	8.1245	32.173
38	19.556	8.1616	32.284
39	20.111	8.1971	32.390
40	20.667	8.2313	32.491
41	21.222	8.2640	32.587
42	21.778	8.2956	32.680
43	22.333	8.3259	32.768
44	22.889	8.3551	32.852
45	23.444	8.3832	32.933
46	24.000	8.4103	33.011

Hampstead - 24-26 Redington Gardens
 450mm diameter
 moment condition - 60kN (SLS) Horizontal

Job No.	Sheet No.	Rev.
21495	D1-A	
Drg. Ref.		
Made by	Date	Checked
DBS		

Node	Z/D	K _q	K _c
47	24.556	8.4364	33.085
48	25.111	8.4617	33.157
49	25.667	8.4861	33.226
50	26.222	8.5096	33.292
51	26.778	8.5324	33.356
52	27.333	8.5545	33.418
53	27.889	8.5758	33.477
54	28.444	8.5965	33.534
55	29.000	8.6166	33.589
56	29.370	8.6296	33.625
57	29.741	8.6423	33.660
58	30.111	8.6548	33.695

Sections

Name	Input Type	Description	Material	Class	Effective Width	EI
					[m]	[kNm ²]
Section 1	Explicit	Description, Material and Class not applicable			0.45000	40258.

Pile Properties

Level	Section
[m]	
43.300	Section 1

Pile base at 29.750000 m

Applied Loads and Displacements

No.	Level	Force	Moment	Displacement
	[m]	[kN]	[kNm]	[mm]
1	43.300	60.000	0.0	0.0

Restraints

No.	Node	Lateral Stiffness	Rotational Stiffness
		[kN/m]	[kNm/rad]
1	1	0.0	20000.

Surcharges

No.	Level	Pressure
	[m]	[kN/m ²]
1	43.300	10.000

Geometry and Initial state

Node	Level	Soil	EI	Effective Width	Water Pressure	Soil Disp
	[m]		[kNm ²]	[m]	[kN/m ²]	[mm]
1	43.300	1	40258.	0.45000	0.0	0.0
2	43.056	1	40258.	0.45000	2.3930	0.0
3	42.812	1	40258.	0.45000	4.7861	0.0
4	42.568	1	40258.	0.45000	7.1791	0.0
5	42.324	1	40258.	0.45000	9.5722	0.0
6	42.080	1	40258.	0.45000	11.965	0.0
7	41.836	1	40258.	0.45000	14.358	0.0
8	41.592	1	40258.	0.45000	16.751	0.0
9	41.348	1	40258.	0.45000	19.144	0.0
10	41.105	1	40258.	0.45000	21.537	0.0
11	40.861	1	40258.	0.45000	23.930	0.0
12	40.617	1	40258.	0.45000	26.323	0.0
13	40.373	1	40258.	0.45000	28.717	0.0
14	40.129	1	40258.	0.45000	31.110	0.0
15	39.885	1	40258.	0.45000	33.503	0.0
16	39.641	1	40258.	0.45000	35.896	0.0
17	39.397	1	40258.	0.45000	38.289	0.0
18	39.153	1	40258.	0.45000	40.682	0.0
19	38.909	1	40258.	0.45000	43.075	0.0
20	38.665	1	40258.	0.45000	45.468	0.0
21	38.421	1	40258.	0.45000	47.861	0.0

Hampstead - 24-26 Redington Gardens
 450mm diameter
 moment condition - 60kN (SLS) Horizontal

Job No.	Sheet No.	Rev.
21495	D1-A	
Drg. Ref.		
Made by DBS	Date	Checked

Node	Level	Soil	EI	Effective Width	Water Pressure	Soil Disp
	[m]		[kNm ²]	[m]	[kN/m ²]	[mm]
22	38.177	1	40258.	0.45000	50.254	0.0
23	37.933	1	40258.	0.45000	52.647	0.0
24	37.689	1	40258.	0.45000	55.040	0.0
25	37.445	1	40258.	0.45000	57.433	0.0
26	37.202	1	40258.	0.45000	59.826	0.0
27	36.958	1	40258.	0.45000	62.219	0.0
28	36.714	1	40258.	0.45000	64.612	0.0
29	36.470	1	40258.	0.45000	67.005	0.0
30	36.226	1	40258.	0.45000	69.398	0.0
31	35.982	1	40258.	0.45000	71.791	0.0
32	35.738	1	40258.	0.45000	74.184	0.0
33	35.494	1	40258.	0.45000	76.577	0.0
34	35.250	1	40258.	0.45000	78.970	0.0
35	35.083	1	40258.	0.45000	80.605	0.0
36	34.917	2	40258.	0.45000	82.240	0.0
37	34.750	2	40258.	0.45000	83.875	0.0
38	34.500	2	40258.	0.45000	86.328	0.0
39	34.250	2	40258.	0.45000	88.780	0.0
40	34.000	2	40258.	0.45000	91.233	0.0
41	33.750	2	40258.	0.45000	93.685	0.0
42	33.500	2	40258.	0.45000	96.138	0.0
43	33.250	2	40258.	0.45000	98.590	0.0
44	33.000	2	40258.	0.45000	101.04	0.0
45	32.750	2	40258.	0.45000	103.50	0.0
46	32.500	2	40258.	0.45000	105.95	0.0
47	32.250	2	40258.	0.45000	108.40	0.0
48	32.000	2	40258.	0.45000	110.85	0.0
49	31.750	2	40258.	0.45000	113.31	0.0
50	31.500	2	40258.	0.45000	115.76	0.0
51	31.250	2	40258.	0.45000	118.21	0.0
52	31.000	2	40258.	0.45000	120.66	0.0
53	30.750	2	40258.	0.45000	123.12	0.0
54	30.500	2	40258.	0.45000	125.57	0.0
55	30.250	2	40258.	0.45000	128.02	0.0
56	30.083	2	40258.	0.45000	129.66	0.0
57	29.917	3	40258.	0.45000	131.29	0.0
58	29.750	3	40258.	0.45000	132.93	0.0

Output for load increment 1

Iteration	Max Inc	at node	Disp error	Pressure error
			[mm]	[kN/m ²]
20	8.14	1	0.0095	0.63
30	8.18	1	0.0008	0.04

Node	Level	Defl	Rotation	Soil Pressure	Bending	Shear
	[m]	[mm]	[rad]	[kN/m ²]	[kNm]	[kN]
1	43.300	-8.1765	-0.0029128	1	-36.878	0.0
1	43.300				-58.256	-90.000
2	43.056	-7.4282	-0.0032008	1	-47.010	-36.796
3	42.812	-6.6252	-0.0033626	1	-62.563	-16.594
4	42.568	-5.7972	-0.0034070	1	-79.258	1.9331
5	42.324	-4.9716	-0.0033456	1	-96.892	18.337
6	42.080	-4.1724	-0.0031927	1	-115.31	32.147
7	41.836	-3.4200	-0.0029655	1	-134.38	42.869
8	41.592	-2.7300	-0.0026843	1	-141.96	49.993
9	41.348	-2.1129	-0.0023715	1	-109.87	53.315
10	41.105	-1.5739	-0.0020475	1	-81.842	53.695
11	40.861	-1.1136	-0.0017278	1	-57.910	51.884
12	40.617	-0.72965	-0.0014239	1	-37.942	48.522
13	40.373	-0.41706	-0.0011434	1	-21.687	44.143
14	40.129	-0.16951	-891.26E-6	1	-8.8145	39.184
15	39.885	0.020267	-669.91E-6	1	1.0539	33.990
16	39.641	0.15988	-479.99E-6	1	8.3140	28.823
17	39.397	0.25694	-320.74E-6	1	13.361	23.879
18	39.153	0.31872	-190.40E-6	1	16.573	19.293
19	38.909	0.35198	-86.529E-6	1	18.303	15.150
20	38.665	0.36286	-6.3107E-6	1	18.868	11.498
21	38.421	0.35674	53.275E-6	1	18.550	8.3506
22	38.177	0.33830	95.262E-6	1	17.591	5.7002
23	37.933	0.31146	122.58E-6	1	16.196	3.5209
24	37.689	0.27946	137.98E-6	1	14.532	1.7753
25	37.445	0.24490	143.95E-6	1	12.735	0.41881
26	37.202	0.20982	142.69E-6	1	10.910	-0.59667
27	36.958	0.17572	136.14E-6	1	9.1373	-1.3200

Hampstead - 24-26 Redington Gardens
 450mm diameter
 moment condition - 60kN (SLS) Horizontal

Job No.	Sheet No.	Rev.
21495	D1-A	
Drg. Ref.		
Made by	Date	Checked
DBS		

Node	Level [m]	Defl [mm]	Rotation [rad]	Soil Pressure [kN/m ²]	Bending [kNm]	Shear [kN]
28	36.714	0.14370	125.91E-6	1	7.4721	-1.7986
29	36.470	0.11448	113.36E-6	1	5.9528	-2.0772
30	36.226	0.088492	99.561E-6	1	4.6016	-2.1963
31	35.982	0.065934	85.386E-6	1	3.4286	-2.1923
32	35.738	0.046813	71.480E-6	1	2.4343	-2.0964
33	35.494	0.031000	58.319E-6	1	1.6120	-1.9353
34	35.250	0.018273	46.233E-6	1	0.95017	-1.7311
35	35.083	0.011204	38.698E-6	1	0.58259	-1.5769
36	34.917	0.0053378	31.801E-6	2	0.47447	-1.4154
37	34.750	566.40E-6	25.569E-6	2	0.050347	-1.2481
38	34.500	-0.0047847	17.495E-6	2	-0.42531	-0.99580
39	34.250	-0.0083058	10.916E-6	2	-0.73830	-0.75551
40	34.000	-0.010359	5.7305E-6	2	-0.92080	-0.53598
41	33.750	-0.011275	1.7927E-6	2	-1.0022	-0.34235
42	33.500	-0.011345	-1.0648E-6	2	-1.0085	-0.17691
43	33.250	-0.010818	-3.0177E-6	2	-0.96161	-0.039832
44	33.000	-0.0098976	-4.2380E-6	2	-0.87979	0.070202
45	32.750	-0.0087467	-4.8864E-6	2	-0.77749	0.15549
46	32.500	-0.0074900	-5.1078E-6	2	-0.66577	0.21892
47	32.250	-0.0062179	-5.0282E-6	2	-0.55270	0.26361
48	32.000	-0.0049921	-4.7539E-6	2	-0.44374	0.29277
49	31.750	-0.0038499	-4.3720E-6	2	-0.34221	0.30944
50	31.500	-0.0028093	-3.9512E-6	2	-0.24972	0.31649
51	31.250	-0.0018733	-3.5430E-6	2	-0.16651	0.31652
52	31.000	-0.0010337	-3.1839E-6	2	-0.091885	0.31186
53	30.750	-275.32E-6	-2.8965E-6	2	-0.024473	0.30462
54	30.500	421.34E-6	-2.6908E-6	2	0.037452	0.29669
55	30.250	0.0010768	-2.5658E-6	2	0.095715	0.28981
56	30.083	0.0015004	-2.5223E-6	2	0.13337	0.28672
57	29.917	0.0019189	-2.5036E-6	3	0.25586	0.28530
58	29.750	0.0023358	-2.4996E-6	3	0.31143	0.28707

- The letter "P" next to a result indicates that the effective earth pressure is greater than 0.99 times the passive limit, but within the convergence pressure limit.

EXTREME values so far:-

Deflections		Rotations		Moments		Shears	
Min	Max	Min	Max	Min	Max	Min	Max
[mm]	[mm]	[rad]	[rad]	[kNm]	[kNm]	[kN]	[kN]
-8.1765	0.36286	-0.0034070	143.95E-6	-58.256	53.695	-90.000	21.238

RESTRAINT FORCES

No.	Node	Lateral force	Moment
		[kN]	[kNm]
1	1	0.0	58.256

Hampstead - 24-26 Redington Gardens
 450mm diameter
 moment condition - 60kN (SLS) Horizontal

Job No.	Sheet No.	Rev.
21495	D1-B	
Drg. Ref.		
Made by DBS	Date	Checked

Notes

Case D1-B

General Data

Number of increments = 1
 Increment applied loads only

Convergence Control

Maximum number of iterations = 300
 Maximum displacement error [mm] = 0.0010000
 Maximum pressure error [kN/m²] = 0.10000
 Damping coefficient = 1.0000
 Maximum incremental deflection [m] = 2.0000

Soil Data

Elastic-plastic soils
 Factor on soil E value: 0.8000

No.	Level	E	Unit	Phi	Factored K _q	Factored K _c	c(top)	dc/dz
	[m]	[kN/m ²]	[kN/m ³]	[deg]			[kN/m ²]	[kN/m ² /m]
1	43.299999	29250.	20.000	25.000	-	-	0.0	0.0
2	35.000000	50000.	20.000	25.000	-	-	0.0	0.0
3	30.000000	75000.	20.000	25.000	-	-	0.0	0.0

Calculated K_q and K_c Values

Node	Z/D	K _q	K _c
1	0.0	2.3566	4.7453
2	0.54209	2.6800	8.2519
3	1.0842	2.9526	10.738
4	1.6263	3.1855	12.593
5	2.1684	3.3868	14.030
6	2.7104	3.5624	15.175
7	3.2525	3.7171	16.110
8	3.7946	3.8543	16.888
9	4.3367	3.9768	17.544
10	4.8788	4.0870	18.106
11	5.4209	4.1865	18.593
12	5.9630	4.2768	19.018
13	6.5051	4.3592	19.393
14	7.0471	4.4347	19.725
15	7.5892	4.5040	20.023
16	8.1313	4.5680	20.291
17	8.6734	4.6271	20.533
18	9.2155	4.6820	20.752
19	9.7576	4.7331	20.953
20	10.300	4.7807	21.137
21	10.842	4.8253	21.306
22	11.384	4.8670	21.462
23	11.926	4.9062	21.606
24	12.468	4.9431	21.740
25	13.010	4.9778	21.865
26	13.552	5.0106	21.981
27	14.094	5.0416	22.090
28	14.636	5.0710	22.192
29	15.178	5.0988	22.288
30	15.721	5.1252	22.378
31	16.263	5.1504	22.463
32	16.805	5.1743	22.543
33	17.347	5.1972	22.619
34	17.889	5.2189	22.691
35	18.259	5.2332	22.738
36	18.630	5.2471	22.783
37	19.000	5.2606	22.827
38	19.556	5.2800	22.890
39	20.111	5.2987	22.950
40	20.667	5.3165	23.007
41	21.222	5.3336	23.061
42	21.778	5.3501	23.113
43	22.333	5.3658	23.163
44	22.889	5.3810	23.210
45	23.444	5.3956	23.255
46	24.000	5.4096	23.299

Hampstead - 24-26 Redington Gardens
 450mm diameter
 moment condition - 60kN (SLS) Horizontal

Job No.	Sheet No.	Rev.
21495	D1-B	
Drg. Ref.		
Made by DBS	Date	Checked

Node	Z/D	K _q	K _c
47	24.556	5.4232	23.341
48	25.111	5.4362	23.381
49	25.667	5.4488	23.419
50	26.222	5.4609	23.456
51	26.778	5.4727	23.492
52	27.333	5.4840	23.526
53	27.889	5.4950	23.559
54	28.444	5.5056	23.591
55	29.000	5.5159	23.622
56	29.370	5.5225	23.642
57	29.741	5.5291	23.661
58	30.111	5.5355	23.680

Sections

Name	Input Type	Description	Material	Class	Effective Width	EI
					[m]	[kNm ²]
Section 1	Explicit	Description, Material and Class not applicable			0.45000	40258.

Pile Properties

Level	Section
[m]	
43.300	Section 1

Pile base at 29.750000 m

Applied Loads and Displacements

No.	Level	Force	Moment	Displacement
	[m]	[kN]	[kNm]	[mm]
1	43.300	60.000	0.0	0.0

Restraints

No.	Node	Lateral Stiffness	Rotational Stiffness
		[kN/m]	[kNm/rad]
1	1	0.0	20000.

Surcharges

No.	Level	Pressure
	[m]	[kN/m ²]
1	43.300	10.000

Geometry and Initial state

Node	Level	Soil	EI	Effective Width	Water Pressure	Soil Disp
	[m]		[kNm ²]	[m]	[kN/m ²]	[mm]
1	43.300	1	40258.	0.45000	0.0	0.0
2	43.056	1	40258.	0.45000	2.3930	0.0
3	42.812	1	40258.	0.45000	4.7861	0.0
4	42.568	1	40258.	0.45000	7.1791	0.0
5	42.324	1	40258.	0.45000	9.5722	0.0
6	42.080	1	40258.	0.45000	11.965	0.0
7	41.836	1	40258.	0.45000	14.358	0.0
8	41.592	1	40258.	0.45000	16.751	0.0
9	41.348	1	40258.	0.45000	19.144	0.0
10	41.105	1	40258.	0.45000	21.537	0.0
11	40.861	1	40258.	0.45000	23.930	0.0
12	40.617	1	40258.	0.45000	26.323	0.0
13	40.373	1	40258.	0.45000	28.717	0.0
14	40.129	1	40258.	0.45000	31.110	0.0
15	39.885	1	40258.	0.45000	33.503	0.0
16	39.641	1	40258.	0.45000	35.896	0.0
17	39.397	1	40258.	0.45000	38.289	0.0
18	39.153	1	40258.	0.45000	40.682	0.0
19	38.909	1	40258.	0.45000	43.075	0.0
20	38.665	1	40258.	0.45000	45.468	0.0
21	38.421	1	40258.	0.45000	47.861	0.0

Hampstead - 24-26 Redington Gardens
 450mm diameter
 moment condition - 60kN (SLS) Horizontal

Job No.	Sheet No.	Rev.
21495	D1-B	
Drg. Ref.		
Made by DBS	Date	Checked

Node	Level	Soil	EI	Effective Width	Water Pressure	Soil Disp
	[m]		[kNm ²]	[m]	[kN/m ²]	[mm]
22	38.177	1	40258.	0.45000	50.254	0.0
23	37.933	1	40258.	0.45000	52.647	0.0
24	37.689	1	40258.	0.45000	55.040	0.0
25	37.445	1	40258.	0.45000	57.433	0.0
26	37.202	1	40258.	0.45000	59.826	0.0
27	36.958	1	40258.	0.45000	62.219	0.0
28	36.714	1	40258.	0.45000	64.612	0.0
29	36.470	1	40258.	0.45000	67.005	0.0
30	36.226	1	40258.	0.45000	69.398	0.0
31	35.982	1	40258.	0.45000	71.791	0.0
32	35.738	1	40258.	0.45000	74.184	0.0
33	35.494	1	40258.	0.45000	76.577	0.0
34	35.250	1	40258.	0.45000	78.970	0.0
35	35.083	1	40258.	0.45000	80.605	0.0
36	34.917	2	40258.	0.45000	82.240	0.0
37	34.750	2	40258.	0.45000	83.875	0.0
38	34.500	2	40258.	0.45000	86.328	0.0
39	34.250	2	40258.	0.45000	88.780	0.0
40	34.000	2	40258.	0.45000	91.233	0.0
41	33.750	2	40258.	0.45000	93.685	0.0
42	33.500	2	40258.	0.45000	96.138	0.0
43	33.250	2	40258.	0.45000	98.590	0.0
44	33.000	2	40258.	0.45000	101.04	0.0
45	32.750	2	40258.	0.45000	103.50	0.0
46	32.500	2	40258.	0.45000	105.95	0.0
47	32.250	2	40258.	0.45000	108.40	0.0
48	32.000	2	40258.	0.45000	110.85	0.0
49	31.750	2	40258.	0.45000	113.31	0.0
50	31.500	2	40258.	0.45000	115.76	0.0
51	31.250	2	40258.	0.45000	118.21	0.0
52	31.000	2	40258.	0.45000	120.66	0.0
53	30.750	2	40258.	0.45000	123.12	0.0
54	30.500	2	40258.	0.45000	125.57	0.0
55	30.250	2	40258.	0.45000	128.02	0.0
56	30.083	2	40258.	0.45000	129.66	0.0
57	29.917	3	40258.	0.45000	131.29	0.0
58	29.750	3	40258.	0.45000	132.93	0.0

Output for load increment 1

Iteration	Max Inc	at node	Disp error	Pressure error
			[mm]	[kN/m ²]
20	8.51	1	0.0319	1.94
40	8.73	1	0.0014	0.09
43	8.73	1	0.0009	0.05

Node	Level	Defl	Rotation	Soil Pressure	Bending	Shear
	[m]	[mm]	[rad]	[kN/m ²]	[kNm]	[kN]
1	43.300	-8.7304	-0.0028623	1	-26.440	0.0
2	43.300				-57.246	-78.000
2	43.056	-7.9944	-0.0031526	1	-33.462	-38.573
3	42.812	-7.2013	-0.0033325	1	-44.205	-20.795
4	42.568	-6.3771	-0.0034082	1	-55.610	-4.2018
5	42.324	-5.5463	-0.0033880	1	-67.542	10.902
6	42.080	-4.7311	-0.0032817	1	-79.901	24.198
7	41.836	-3.9512	-0.0031014	1	-92.609	35.354
8	41.592	-3.2229	-0.0028610	1	-105.61	44.031
9	41.348	-2.5590	-0.0025767	1	-118.85	49.879
10	41.105	-1.9679	-0.0022666	1	-102.33	52.545
11	40.861	-1.4538	-0.0019487	1	-75.598	52.470
12	40.617	-1.0167	-0.0016374	1	-52.867	50.371
13	40.373	-0.65356	-0.0013432	1	-33.985	46.857
14	40.129	-0.35939	-0.0010731	1	-18.688	42.432
15	39.885	-0.12772	-831.35E-6	1	-6.6414	37.507
16	39.641	0.048676	-620.03E-6	1	2.5312	32.404
17	39.397	0.17728	-439.48E-6	1	9.2187	27.369
18	39.153	0.26551	-288.74E-6	1	13.807	22.581
19	38.909	0.32042	-165.93E-6	1	16.662	18.162
20	38.665	0.34854	-68.593E-6	1	18.124	14.190
21	38.421	0.35573	6.0996E-6	1	18.498	10.703
22	38.177	0.34716	61.118E-6	1	18.052	7.7111
23	37.933	0.32727	99.426E-6	1	17.018	5.2028
24	37.689	0.29978	123.87E-6	1	15.589	3.1502
25	37.445	0.26775	137.10E-6	1	13.923	1.5150
26	37.202	0.23361	141.50E-6	1	12.148	0.25266

Hampstead - 24-26 Redington Gardens
 450mm diameter
 moment condition - 60kN (SLS) Horizontal

Job No.	Sheet No.	Rev.
21495	D1-B	
Drg. Ref.		
Made by DBS	Date	Checked

Node	Level [m]	Defl [mm]	Rotation [rad]	Soil Pressure [kN/m ²]	Bending [kNm]	Shear [kN]
27	36.958	0.19926	139.19E-6	1	10.361	-0.68440
28	36.714	0.16610	132.00E-6	1	8.6371	-1.3440
29	36.470	0.13513	121.47E-6	1	7.0267	-1.7723
30	36.226	0.10701	108.87E-6	1	5.5643	-2.0125
31	35.982	0.082101	95.214E-6	1	4.2693	-2.1036
32	35.738	0.060573	81.309E-6	1	3.1498	-2.0805
33	35.494	0.042404	67.755E-6	1	2.2050	-1.9729
34	35.250	0.027453	54.986E-6	1	1.4275	-1.8064
35	35.083	0.018973	46.861E-6	1	0.98659	-1.6706
36	34.917	0.011801	39.302E-6	2	1.0490	-1.5225
37	34.750	0.0058377	32.363E-6	2	0.51891	-1.3613
38	34.500	-0.0010761	23.203E-6	2	-0.095654	-1.1073
39	34.250	-0.0058903	15.563E-6	2	-0.52359	-0.85599
40	34.000	-0.0089800	9.3910E-6	2	-0.79822	-0.61941
41	33.750	-0.010698	4.5700E-6	2	-0.95097	-0.40528
42	33.500	-0.011365	947.73E-9	2	-1.0102	-0.21790
43	33.250	-0.011258	-1.6471E-6	2	-1.0007	-0.058932
44	33.000	-0.010612	-3.3902E-6	2	-0.94332	0.071892
45	32.750	-0.0096197	-4.4512E-6	2	-0.85508	0.17619
46	32.500	-0.0084305	-4.9872E-6	2	-0.74938	0.25643
47	32.250	-0.0071581	-5.1383E-6	2	-0.63628	0.31560
48	32.000	-0.0058833	-5.0256E-6	2	-0.52296	0.35687
49	31.750	-0.0046589	-4.7502E-6	2	-0.41412	0.38343
50	31.500	-0.0035149	-4.3941E-6	2	-0.31244	0.39835
51	31.250	-0.0024633	-4.0205E-6	2	-0.21896	0.40448
52	31.000	-0.0015023	-3.6760E-6	2	-0.13353	0.40445
53	30.750	-620.31E-6	-3.3914E-6	2	-0.055139	0.40067
54	30.500	199.80E-6	-3.1830E-6	2	0.017760	0.39533
55	30.250	977.83E-6	-3.0543E-6	2	0.086919	0.39050
56	30.083	0.0014827	-3.0089E-6	2	0.13180	0.38863
57	29.917	0.0019822	-2.9893E-6	3	0.26430	0.38841
58	29.750	0.0024800	-2.9850E-6	3	0.33066	0.39150

- The letter "P" next to a result indicates that the effective earth pressure is greater than 0.99 times the passive limit, but within the convergence pressure limit.

EXTREME values so far:-

Deflections		Rotations		Moments		Shears	
Min	Max	Min	Max	Min	Max	Min	Max
[mm]	[mm]	[rad]	[rad]	[kNm]	[kNm]	[kN]	[kN]
-8.7304	0.35573	-0.0034082	141.50E-6	-57.246	52.545	-78.000	20.780

RESTRAINT FORCES

No.	Node	Lateral force	Moment
		[kN]	[kNm]
1	1	0.0	57.246

Hampstead - 24-26 Redington Gardens
 450mm diameter
 moment condition - 50kN (SLS) Horizontal

Job No.	Sheet No.	Rev.
21495	D2-A	
Drg. Ref.		
Made by DBS	Date	Checked

Notes

Case D2-A

General Data

Number of increments = 1
 Increment applied loads only

Convergence Control

Maximum number of iterations = 300
 Maximum displacement error [mm] = 0.0010000
 Maximum pressure error [kN/m²] = 0.10000
 Damping coefficient = 1.0000
 Maximum incremental deflection [m] = 2.0000

Soil Data

Elastic-plastic soils
 Factor on soil E value: 0.8000

No.	Level	E	Unit	Phi	Factored K _q	Factored K _c	c(top)	dc/dz
	[m]	[kN/m ²]	[kN/m ³]	[deg]			[kN/m ²]	[kN/m ² /m]
1	43.299999	29250.	20.000	25.000	-	-	0.0	0.0
2	35.000000	50000.	20.000	25.000	-	-	0.0	0.0
3	30.000000	75000.	20.000	25.000	-	-	0.0	0.0

Calculated K_q and K_c Values

Node	Z/D	K _q	K _c
1	0.0	3.2869	5.6339
2	0.96296	4.0912	12.705
3	1.9259	4.7209	17.157
4	2.8889	5.2273	20.218
5	3.8518	5.6434	22.452
6	4.8148	5.9913	24.153
7	5.7778	6.2866	25.493
8	6.7407	6.5404	26.575
9	7.7037	6.7607	27.467
10	8.6667	6.9539	28.215
11	9.6296	7.1247	28.852
12	10.593	7.2767	29.400
13	11.556	7.4129	29.877
14	12.519	7.5356	30.296
15	13.481	7.6467	30.667
16	14.444	7.7478	30.997
17	15.407	7.8403	31.293
18	16.370	7.9250	31.560
19	17.333	8.0031	31.803
20	18.074	8.0591	31.974
21	18.815	8.1118	32.134
22	19.556	8.1616	32.284
23	20.543	8.2238	32.469
24	21.531	8.2817	32.639
25	22.519	8.3357	32.796
26	23.506	8.3862	32.942
27	24.494	8.4336	33.077
28	25.481	8.4780	33.203
29	26.469	8.5199	33.321
30	27.457	8.5593	33.431
31	28.444	8.5965	33.534
32	29.185	8.6231	33.607
33	29.926	8.6486	33.677
34	30.667	8.6731	33.744

Sections

Name	Input Type	Description	Material	Class	Effective Width	EI
					[m]	[kNm ²]
Section 1	Explicit	Description, Material and Class not applicable			0.45000	40258.

Hampstead - 24-26 Redington Gardens
 450mm diameter
 moment condition - 50kN (SLS) Horizontal

Job No.	Sheet No.	Rev.
21495	D2-A	
Drg. Ref.		
Made by DBS	Date	Checked

Name	Input Type	Description	Material	Class	Effective Width	EI
					[m]	[kNm ²]
Section 1	Explicit	Description, Material and Class not applicable			0.45000	40258.

Pile Properties

Level [m]	Section
43.300	Section 1

Pile base at 29.500000 m

Applied Loads and Displacements

No.	Level [m]	Force [kN]	Moment [kNm]	Displacement [mm]
1	43.300	50.000	0.0	0.0

Restraints

No.	Node	Lateral Stiffness [kN/m]	Rotational Stiffness [kNm/rad]
1	1	0.0	20000.

Surcharges

No.	Level [m]	Pressure [kN/m ²]
1	43.300	10.000

Geometry and Initial state

Node	Level [m]	Soil	EI [kNm ²]	Effective Width [m]	Water Pressure [kN/m ²]	Soil Disp [mm]
1	43.300	1	40258.	0.45000	0.0	0.0
2	42.867	1	40258.	0.45000	4.2510	0.0
3	42.433	1	40258.	0.45000	8.5020	0.0
4	42.000	1	40258.	0.45000	12.753	0.0
5	41.567	1	40258.	0.45000	17.004	0.0
6	41.133	1	40258.	0.45000	21.255	0.0
7	40.700	1	40258.	0.45000	25.506	0.0
8	40.267	1	40258.	0.45000	29.757	0.0
9	39.833	1	40258.	0.45000	34.008	0.0
10	39.400	1	40258.	0.45000	38.259	0.0
11	38.967	1	40258.	0.45000	42.510	0.0
12	38.533	1	40258.	0.45000	46.761	0.0
13	38.100	1	40258.	0.45000	51.012	0.0
14	37.667	1	40258.	0.45000	55.263	0.0
15	37.233	1	40258.	0.45000	59.514	0.0
16	36.800	1	40258.	0.45000	63.765	0.0
17	36.367	1	40258.	0.45000	68.016	0.0
18	35.933	1	40258.	0.45000	72.267	0.0
19	35.500	1	40258.	0.45000	76.518	0.0
20	35.167	1	40258.	0.45000	79.788	0.0
21	34.833	2	40258.	0.45000	83.058	0.0
22	34.500	2	40258.	0.45000	86.328	0.0
23	34.056	2	40258.	0.45000	90.688	0.0
24	33.611	2	40258.	0.45000	95.048	0.0
25	33.167	2	40258.	0.45000	99.408	0.0
26	32.722	2	40258.	0.45000	103.77	0.0
27	32.278	2	40258.	0.45000	108.13	0.0
28	31.833	2	40258.	0.45000	112.49	0.0
29	31.389	2	40258.	0.45000	116.85	0.0
30	30.944	2	40258.	0.45000	121.21	0.0
31	30.500	2	40258.	0.45000	125.57	0.0
32	30.167	2	40258.	0.45000	128.84	0.0
33	29.833	3	40258.	0.45000	132.11	0.0
34	29.500	3	40258.	0.45000	135.38	0.0

Output for load increment 1

Iteration	Max Inc	at node	Disp error	Pressure error
			[mm]	[kN/m ²]
20	5.75	1	0.0035	0.24
25	5.76	1	0.0009	0.05

Node	Level	Defl	Rotation	Soil Pressure	Bending	Shear
------	-------	------	----------	---------------	---------	-------

Hampstead - 24-26 Redington Gardens
 450mm diameter
 moment condition - 50kN (SLS) Horizontal

Job No.	Sheet No.	Rev.
21495	D2-A	
Drg. Ref.		
Made by	Date	Checked
DBS		

	[m]	[mm]	[rad]		[kN/m ²]	[kNm]	[kN]	
1	43.300	-5.7641	-0.0021762	1	-39.991	0.0	0.0	P
1	43.300					-43.525	-75.000	
2	42.867	-4.7435	-0.0024789	1	-58.977	-12.715	-65.351	P
3	42.433	-3.6598	-0.0024769	1	-88.901	13.112	-50.932	P
4	42.000	-2.6312	-0.0022373	1	-121.52	31.427	-30.417	P
5	41.567	-1.7413	-0.0018559	1	-90.546	39.473	-9.7403	
6	41.133	-1.0293	-0.0014293	1	-53.525	39.868	4.3066	
7	40.700	-0.49964	-0.0010228	1	-25.981	35.741	12.058	
8	40.267	-0.13473	-672.74E-6	1	-7.0057	29.418	15.275	
9	39.833	0.093715	-394.02E-6	1	4.8732	22.503	15.483	
10	39.400	0.21721	-187.64E-6	1	11.295	16.000	13.906	
11	38.967	0.26572	-46.240E-6	1	13.818	10.451	11.458	
12	38.533	0.26502	41.599E-6	1	13.781	6.0696	8.7668	
13	38.100	0.23559	88.426E-6	1	12.251	2.8529	6.2286	
14	37.667	0.19260	106.08E-6	1	10.015	0.67148	4.0577	
15	37.233	0.14641	104.69E-6	1	7.6132	-0.66372	2.3389	
16	36.800	0.10346	92.271E-6	1	5.3799	-1.3556	1.0721	
17	36.367	0.067180	74.730E-6	1	3.4934	-1.5929	0.20695	
18	35.933	0.038851	56.105E-6	1	2.0202	-1.5350	-0.33062	
19	35.500	0.018350	38.903E-6	1	0.95420	-1.3063	-0.60989	
20	35.167	0.0073357	27.490E-6	1	0.38146	-1.0756	-0.72080	
21	34.833	-189.91E-6	17.996E-6	2	-0.016881	-0.82579	-0.74815	
22	34.500	-0.0048835	10.497E-6	2	-0.43409	-0.57683	-0.70890	
23	34.056	-0.0078559	3.4072E-6	2	-0.69831	-0.27865	-0.60108	
24	33.611	-0.0083304	-858.71E-9	2	-0.74048	-0.042538	-0.45721	
25	33.167	-0.0074064	-3.0071E-6	2	-0.65834	0.12775	-0.31732	
26	32.722	-0.0058694	-3.7243E-6	2	-0.52173	0.23953	-0.19932	
27	32.278	-0.0042221	-3.5893E-6	2	-0.37530	0.30493	-0.10961	
28	31.833	-0.0027400	-3.0423E-6	2	-0.24355	0.33696	-0.047729	
29	31.389	-0.0015339	-2.3868E-6	2	-0.13635	0.34735	-0.0097391	
30	30.944	-606.78E-6	-1.8094E-6	2	-0.053936	0.34562	0.0092894	
31	30.500	99.836E-6	-1.4034E-6	2	0.0088743	0.33909	0.013907	
32	30.167	535.17E-6	-1.2265E-6	2	0.047571	0.33472	0.0095622	
33	29.833	928.29E-6	-1.1468E-6	3	0.12377	0.33272	-0.0032885	
34	29.500	0.0013065	-1.1287E-6	3	0.17421	0.33691	-0.025637	

- The letter "P" next to a result indicates that the effective earth pressure is greater than 0.99 times the passive limit, but within the convergence pressure limit.

EXTREME values so far:-

Deflections		Rotations		Moments		Shears	
Min	Max	Min	Max	Min	Max	Min	Max
[mm]	[mm]	[rad]	[rad]	[kNm]	[kNm]	[kN]	[kN]
-5.7641	0.26572	-0.0024789	106.08E-6	-43.525	39.868	-75.000	15.483

RESTRAINT FORCES

No.	Node	Lateral force	Moment
		[kN]	[kNm]
1	1	0.0	43.525

Hampstead - 24-26 Redington Gardens
 450mm diameter
 moment condition - 50kN (SLS) Horizontal

Job No.	Sheet No.	Rev.
21495	D2-B	
Drg. Ref.		
Made by DBS	Date	Checked

Notes

Case D2-B

General Data

Number of increments = 1
 Increment applied loads only

Convergence Control

Maximum number of iterations = 300
 Maximum displacement error [mm] = 0.0010000
 Maximum pressure error [kN/m²] = 0.10000
 Damping coefficient = 1.0000
 Maximum incremental deflection [m] = 2.0000

Soil Data

Elastic-plastic soils
 Factor on soil E value: 0.8000

No.	Level	E	Unit	Phi	Factored K _q	Factored K _c	c (top)	dc/dz
	[m]	[kN/m ²]	[kN/m ³]	[deg]			[kN/m ²]	[kN/m ² /m]
1	43.299999	29250.	20.000	25.000	-	-	0.0	0.0
2	35.000000	50000.	20.000	25.000	-	-	0.0	0.0
3	30.000000	75000.	20.000	25.000	-	-	0.0	0.0

Calculated K_q and K_c Values

Node	Z/D	K _q	K _c
1	0.0	2.3566	4.7453
2	0.96296	2.8955	10.247
3	1.9259	3.3002	13.429
4	2.8889	3.6155	15.503
5	3.8518	3.8679	16.962
6	4.8148	4.0746	18.044
7	5.7778	4.2469	18.879
8	6.7407	4.3928	19.542
9	7.7037	4.5179	20.082
10	8.6667	4.6264	20.530
11	9.6296	4.7214	20.907
12	10.593	4.8052	21.230
13	11.556	4.8797	21.509
14	12.519	4.9464	21.752
15	13.481	5.0064	21.967
16	14.444	5.0607	22.157
17	15.407	5.1101	22.327
18	16.370	5.1552	22.479
19	17.333	5.1966	22.617
20	18.074	5.2261	22.715
21	18.815	5.2539	22.805
22	19.556	5.2800	22.890
23	20.543	5.3126	22.994
24	21.531	5.3428	23.090
25	22.519	5.3710	23.179
26	23.506	5.3972	23.260
27	24.494	5.4217	23.336
28	25.481	5.4446	23.407
29	26.469	5.4662	23.472
30	27.457	5.4865	23.534
31	28.444	5.5056	23.591
32	29.185	5.5192	23.632
33	29.926	5.5323	23.671
34	30.667	5.5448	23.708

Sections

Name	Input Type	Description	Material	Class	Effective Width	EI
					[m]	[kNm ²]
Section 1	Explicit	Description, Material and Class not applicable			0.45000	40258.

Hampstead - 24-26 Redington Gardens
 450mm diameter
 moment condition - 50kN (SLS) Horizontal

Job No.	Sheet No.	Rev.
21495	D2-B	
Drg. Ref.		
Made by	Date	Checked
DBS		

Name	Input Type	Description	Material	Class	Effective Width	EI
					[m]	[kNm ²]
Section 1	Explicit	Description, Material and Class not applicable			0.45000	40258.

Pile Properties

Level	Section
[m]	
43.300	Section 1

Pile base at 29.500000 m

Applied Loads and Displacements

No.	Level	Force	Moment	Displacement
	[m]	[kN]	[kNm]	[mm]
1	43.300	50.000	0.0	0.0

Restraints

No.	Node	Lateral Stiffness	Rotational Stiffness
		[kN/m]	[kNm/rad]
1	1	0.0	20000.

Surcharges

No.	Level	Pressure
	[m]	[kN/m ²]
1	43.300	10.000

Geometry and Initial state

Node	Level	Soil	EI	Effective Width	Water Pressure	Soil Disp
	[m]		[kNm ²]	[m]	[kN/m ²]	[mm]
1	43.300	1	40258.	0.45000	0.0	0.0
2	42.867	1	40258.	0.45000	4.2510	0.0
3	42.433	1	40258.	0.45000	8.5020	0.0
4	42.000	1	40258.	0.45000	12.753	0.0
5	41.567	1	40258.	0.45000	17.004	0.0
6	41.133	1	40258.	0.45000	21.255	0.0
7	40.700	1	40258.	0.45000	25.506	0.0
8	40.267	1	40258.	0.45000	29.757	0.0
9	39.833	1	40258.	0.45000	34.008	0.0
10	39.400	1	40258.	0.45000	38.259	0.0
11	38.967	1	40258.	0.45000	42.510	0.0
12	38.533	1	40258.	0.45000	46.761	0.0
13	38.100	1	40258.	0.45000	51.012	0.0
14	37.667	1	40258.	0.45000	55.263	0.0
15	37.233	1	40258.	0.45000	59.514	0.0
16	36.800	1	40258.	0.45000	63.765	0.0
17	36.367	1	40258.	0.45000	68.016	0.0
18	35.933	1	40258.	0.45000	72.267	0.0
19	35.500	1	40258.	0.45000	76.518	0.0
20	35.167	1	40258.	0.45000	79.788	0.0
21	34.833	2	40258.	0.45000	83.058	0.0
22	34.500	2	40258.	0.45000	86.328	0.0
23	34.056	2	40258.	0.45000	90.688	0.0
24	33.611	2	40258.	0.45000	95.048	0.0
25	33.167	2	40258.	0.45000	99.408	0.0
26	32.722	2	40258.	0.45000	103.77	0.0
27	32.278	2	40258.	0.45000	108.13	0.0
28	31.833	2	40258.	0.45000	112.49	0.0
29	31.389	2	40258.	0.45000	116.85	0.0
30	30.944	2	40258.	0.45000	121.21	0.0
31	30.500	2	40258.	0.45000	125.57	0.0
32	30.167	2	40258.	0.45000	128.84	0.0
33	29.833	3	40258.	0.45000	132.11	0.0
34	29.500	3	40258.	0.45000	135.38	0.0

Output for load increment 1

Iteration	Max at	Disp	Pressure
	Inc node	error	error
	Disp		
	[mm]	[mm]	[kN/m ²]
20	5.98 1	0.0063	0.42
27	6.00 1	0.0010	0.05

Node	Level	Defl	Rotation	Soil Pressure	Bending	Shear
------	-------	------	----------	---------------	---------	-------

Hampstead - 24-26 Redington Gardens
 450mm diameter
 moment condition - 50kN (SLS) Horizontal

Job No.	Sheet No.	Rev.
21495	D2-B	
Drg. Ref.		
Made by	Date	Checked
DBS		

	[m]	[mm]	[rad]		[kN/m ²]	[kNm]	[kN]	
1	43.300	-6.0022	-0.0021216	1	-28.672	0.0	0.0	P
1	43.300					-42.431	-65.000	
2	42.867	-5.0048	-0.0024332	1	-41.740	-15.476	-58.135	P
3	42.433	-3.9325	-0.0024738	1	-62.148	7.9521	-48.006	P
4	42.000	-2.8932	-0.0022905	1	-84.049	26.129	-33.752	P
5	41.567	-1.9702	-0.0019499	1	-102.45	37.203	-15.568	
6	41.133	-1.2138	-0.0015368	1	-63.116	39.621	0.57434	
7	40.700	-0.63785	-0.0011265	1	-33.168	36.706	9.9620	
8	40.267	-0.23072	-762.83E-6	1	-11.997	30.987	14.366	
9	39.833	0.032965	-466.27E-6	1	1.7142	24.255	15.368	
10	39.400	0.18375	-241.52E-6	1	9.5553	17.668	14.270	
11	38.967	0.25192	-83.454E-6	1	13.100	11.889	12.061	
12	38.533	0.26423	18.230E-6	1	13.740	7.2157	9.4438	
13	38.100	0.24250	75.739E-6	1	12.610	3.7039	6.8747	
14	37.667	0.20324	101.05E-6	1	10.568	1.2576	4.6149	
15	37.233	0.15804	104.72E-6	1	8.2182	-0.29569	2.7832	
16	36.800	0.11437	95.275E-6	1	5.9474	-1.1545	1.4020	
17	36.367	0.076434	79.165E-6	1	3.9746	-1.5108	0.43465	
18	35.933	0.046074	60.902E-6	1	2.3958	-1.5312	-0.18646	
19	35.500	0.023545	43.382E-6	1	1.2243	-1.3492	-0.52566	
20	35.167	0.011120	31.444E-6	1	0.57826	-1.1388	-0.67463	
21	34.833	0.0023836	21.294E-6	2	0.21188	-0.89944	-0.73389	
22	34.500	-0.0032921	13.094E-6	2	-0.29263	-0.64951	-0.72417	
23	34.056	-0.0072215	5.1375E-6	2	-0.64191	-0.33904	-0.63438	
24	33.611	-0.0083003	161.29E-9	2	-0.73780	-0.085623	-0.49641	
25	33.167	-0.0077060	-2.5121E-6	2	-0.68498	0.10221	-0.35413	
26	32.722	-0.0063051	-3.5807E-6	2	-0.56045	0.22916	-0.22959	
27	32.278	-0.0046704	-3.6556E-6	2	-0.41514	0.30629	-0.13203	
28	31.833	-0.0031319	-3.2156E-6	2	-0.27839	0.34651	-0.062673	
29	31.389	-0.0018380	-2.6008E-6	2	-0.16337	0.36200	-0.018496	
30	30.944	-813.82E-6	-2.0281E-6	2	-0.072340	0.36296	0.0050751	
31	30.500	-11.812E-6	-1.6131E-6	2	-0.0010499	0.35749	0.012401	
32	30.167	492.17E-6	-1.4289E-6	2	0.043748	0.35332	0.0092117	
33	29.833	951.94E-6	-1.3449E-6	3	0.12693	0.35134	-0.0035888	
34	29.500	0.0013959	-1.3256E-6	3	0.18613	0.35571	-0.027068	

- The letter "P" next to a result indicates that the effective earth pressure is greater than 0.99 times the passive limit, but within the convergence pressure limit.

EXTREME values so far:-

Deflections		Rotations		Moments		Shears	
Min	Max	Min	Max	Min	Max	Min	Max
[mm]	[mm]	[rad]	[rad]	[kNm]	[kNm]	[kN]	[kN]
-6.0022	0.26423	-0.0024738	104.72E-6	-42.431	39.621	-65.000	15.368

RESTRAINT FORCES

No.	Node	Lateral force	Moment
		[kN]	[kNm]
1	1	0.0	42.431

Hampstead - 24-26 Redington Gardens
 450mm diameter
 moment condition - 25kN (SLS) Horizontal

Job No.	Sheet No.	Rev.
21495	D3-A	
Drg. Ref.		
Made by DBS	Date	Checked

Notes

Case D3-A

General Data

Number of increments = 1
 Increment applied loads only

Convergence Control

Maximum number of iterations = 300
 Maximum displacement error [mm] = 0.0010000
 Maximum pressure error [kN/m²] = 0.10000
 Damping coefficient = 1.0000
 Maximum incremental deflection [m] = 2.0000

Soil Data

Elastic-plastic soils
 Factor on soil E value: 0.8000

No.	Level [m]	E [kN/m ²]	Unit wt.	Phi [deg]	Factored K _q	Factored K _c	c(top) [kN/m ²]	dc/dz [kN/m ² /m]
1	43.480000	28800.	20.000	25.000	-	-	0.0	0.0
2	35.000000	50000.	20.000	25.000	-	-	0.0	0.0
3	30.000000	75000.	20.000	25.000	-	-	0.0	0.0

Calculated K_q and K_c Values

Node	Z/D	K _q	K _c
1	0.0	3.2869	5.6339
2	0.89259	4.0391	12.299
3	1.7852	4.6375	16.612
4	2.6778	5.1250	19.632
5	3.5704	5.5296	21.864
6	4.4630	5.8710	23.581
7	5.3556	6.1628	24.942
8	6.2482	6.4152	26.049
9	7.1407	6.6356	26.965
10	8.0333	6.8297	27.738
11	8.9259	7.0019	28.397
12	9.8185	7.1559	28.966
13	10.711	7.2942	29.462
14	11.604	7.4193	29.899
15	12.496	7.5329	30.287
16	13.389	7.6365	30.633
17	14.281	7.7314	30.944
18	15.174	7.8186	31.224
19	16.067	7.8991	31.479
20	16.960	7.9712	31.704
21	17.853	8.0356	31.899
22	18.746	8.0923	32.065
23	19.639	8.1414	32.204
24	20.532	8.1831	32.317
25	21.425	8.2175	32.404
26	22.318	8.2546	32.477
27	23.211	8.2844	32.537
28	24.104	8.3070	32.584
29	25.000	8.3224	32.620
30	25.893	8.3307	32.647
31	26.786	8.3320	32.665
32	27.679	8.3263	32.675
33	28.572	8.3137	32.677
34	29.465	8.2942	32.671
35	30.358	8.2679	32.658
36	31.251	8.2349	32.639
37	32.144	8.1952	32.614
38	33.037	8.1500	32.584
39	33.930	8.1003	32.549
40	34.823	8.0462	32.509
41	35.716	7.9888	32.465
42	36.609	7.9281	32.417
43	37.502	7.8642	32.365
44	38.395	7.7972	32.310
45	39.288	7.7272	32.252
46	40.181	7.6543	32.191

Hampstead - 24-26 Redington Gardens
 450mm diameter
 moment condition - 25kN (SLS) Horizontal

Job No.	Sheet No.	Rev.
21495	D3-A	
Drg. Ref.		
Made by DBS	Date	Checked

Node	Z/D	K _q	K _c
47	33.351	8.7544	33.964
48	33.968	8.7716	34.010
49	34.585	8.7882	34.055
50	35.202	8.8044	34.098
51	35.820	8.8201	34.140
52	36.437	8.8354	34.181
53	37.054	8.8502	34.220
54	37.672	8.8647	34.258
55	38.289	8.8787	34.295

Sections

Name	Input Type	Description	Material	Class	Effective Width	EI
					[m]	[kNm ²]
Section 1	Explicit	Description, Material and Class not applicable			0.45000	40258.

Pile Properties

Level	Section
[m]	
43.480	Section 1

File base at 26.250000 m

Applied Loads and Displacements

No.	Level	Force	Moment	Displacement
	[m]	[kN]	[kNm]	[mm]
1	43.480	25.000	0.0	0.0

Restraints

No.	Node	Lateral Stiffness	Rotational Stiffness
		[kN/m]	[kNm/rad]
1	1	0.0	20000.

Surcharges

No.	Level	Pressure
	[m]	[kN/m ²]
1	43.480	10.000

Geometry and Initial state

Node	Level	Soil	EI	Effective Width	Water Pressure	Soil Disp
	[m]		[kNm ²]	[m]	[kN/m ²]	[mm]
1	43.480	1	40258.	0.45000	0.0	0.0
2	43.078	1	40258.	0.45000	3.9404	0.0
3	42.677	1	40258.	0.45000	7.8807	0.0
4	42.275	1	40258.	0.45000	11.821	0.0
5	41.873	1	40258.	0.45000	15.761	0.0
6	41.472	1	40258.	0.45000	19.702	0.0
7	41.070	1	40258.	0.45000	23.642	0.0
8	40.668	1	40258.	0.45000	27.582	0.0
9	40.267	1	40258.	0.45000	31.523	0.0
10	39.865	1	40258.	0.45000	35.463	0.0
11	39.463	1	40258.	0.45000	39.404	0.0
12	39.062	1	40258.	0.45000	43.344	0.0
13	38.660	1	40258.	0.45000	47.284	0.0
14	38.258	1	40258.	0.45000	51.225	0.0
15	37.857	1	40258.	0.45000	55.165	0.0
16	37.455	1	40258.	0.45000	59.105	0.0
17	37.053	1	40258.	0.45000	63.046	0.0
18	36.652	1	40258.	0.45000	66.986	0.0
19	36.250	1	40258.	0.45000	70.926	0.0
20	35.972	1	40258.	0.45000	73.651	0.0
21	35.694	1	40258.	0.45000	76.376	0.0
22	35.417	1	40258.	0.45000	79.101	0.0
23	35.139	1	40258.	0.45000	81.826	0.0
24	34.861	2	40258.	0.45000	84.551	0.0

Hampstead - 24-26 Redington Gardens
 450mm diameter
 moment condition - 25kN (SLS) Horizontal

Job No.	Sheet No.	Rev.
21495	D3-A	
Drg. Ref.		
Made by DBS	Date	Checked

Node	Level	Soil	EI	Effective Width	Water Pressure	Soil Disp
	[m]		[kNm ²]	[m]	[kN/m ²]	[mm]
25	34.583	2	40258.	0.45000	87.276	0.0
26	34.306	2	40258.	0.45000	90.001	0.0
27	34.028	2	40258.	0.45000	92.726	0.0
28	33.750	2	40258.	0.45000	95.451	0.0
29	33.472	2	40258.	0.45000	98.176	0.0
30	33.194	2	40258.	0.45000	100.90	0.0
31	32.917	2	40258.	0.45000	103.63	0.0
32	32.639	2	40258.	0.45000	106.35	0.0
33	32.361	2	40258.	0.45000	109.08	0.0
34	32.083	2	40258.	0.45000	111.80	0.0
35	31.806	2	40258.	0.45000	114.53	0.0
36	31.528	2	40258.	0.45000	117.25	0.0
37	31.250	2	40258.	0.45000	119.98	0.0
38	30.972	2	40258.	0.45000	122.70	0.0
39	30.694	2	40258.	0.45000	125.43	0.0
40	30.417	2	40258.	0.45000	128.15	0.0
41	30.139	2	40258.	0.45000	130.88	0.0
42	29.861	3	40258.	0.45000	133.60	0.0
43	29.583	3	40258.	0.45000	136.33	0.0
44	29.306	3	40258.	0.45000	139.05	0.0
45	29.028	3	40258.	0.45000	141.78	0.0
46	28.750	3	40258.	0.45000	144.50	0.0
47	28.472	3	40258.	0.45000	147.23	0.0
48	28.194	3	40258.	0.45000	149.95	0.0
49	27.917	3	40258.	0.45000	152.68	0.0
50	27.639	3	40258.	0.45000	155.40	0.0
51	27.361	3	40258.	0.45000	158.13	0.0
52	27.083	3	40258.	0.45000	160.85	0.0
53	26.806	3	40258.	0.45000	163.58	0.0
54	26.528	3	40258.	0.45000	166.30	0.0
55	26.250	3	40258.	0.45000	169.03	0.0

Output for load increment 1

Iteration	Max Inc	at node	Disp error	Pressure error
			[mm]	[kN/m ²]
9	1.88	1	0.0007	0.04

Node	Level	Defl	Rotation	Soil Pressure	Bending	Shear	
	[m]	[mm]	[rad]	[kN/m ²]	[kNm]	[kN]	
1	43.480	-1.8777	-796.82E-6	1	-39.471	0.0	P
1	43.480				-15.936	-37.500	
2	43.078	-1.5349	-887.83E-6	1	-56.923	-2.3066	P
3	42.677	-1.1800	-863.50E-6	1	-60.414	7.1904	
4	42.275	-0.85094	-766.33E-6	1	-43.568	12.301	
5	41.873	-0.56906	-633.98E-6	1	-29.136	14.249	
6	41.472	-0.34283	-492.78E-6	1	-17.553	14.081	
7	41.070	-0.17212	-359.65E-6	1	-8.8124	12.639	
8	40.668	-0.051553	-244.13E-6	1	-2.6395	10.558	
9	40.267	0.026917	-150.38E-6	1	1.3782	8.2843	
10	39.865	0.072224	-78.838E-6	1	3.6979	6.1109	
11	39.463	0.092979	-27.679E-6	1	4.7605	4.2061	
12	39.062	0.096778	6.1638E-6	1	4.9550	2.6468	
13	38.660	0.089874	26.210E-6	1	4.6016	1.4474	
14	38.258	0.077107	35.919E-6	1	3.9479	0.58194	
15	37.857	0.061989	38.390E-6	1	3.1738	0.0031477	
16	37.455	0.046891	36.200E-6	1	2.4008	-0.34522	
17	37.053	0.033262	31.369E-6	1	1.7030	-0.51929	
18	36.652	0.021846	25.383E-6	1	1.1185	-0.56972	
19	36.250	0.012888	19.265E-6	1	0.65989	-0.53894	
20	35.972	0.0080968	15.289E-6	1	0.41455	-0.48963	
21	35.694	0.0043599	11.687E-6	1	0.22322	-0.42593	
22	35.417	0.0015624	8.5344E-6	1	0.079993	-0.35447	
23	35.139	-426.46E-6	5.8677E-6	1	-0.021835	-0.28024	
24	34.861	-0.0017431	3.6939E-6	2	-0.15494	-0.20677	
25	34.583	-0.0025223	1.9919E-6	2	-0.22421	-0.13868	
26	34.306	-0.0028892	716.19E-9	2	-0.25682	-0.078371	
27	34.028	-0.0029544	-190.84E-9	2	-0.26261	-0.026981	
28	33.750	-0.0028116	-791.40E-9	2	-0.24992	0.015291	
29	33.472	-0.0025374	-1.1469E-6	2	-0.22554	0.048885	
30	33.194	-0.0021918	-1.3143E-6	2	-0.19483	0.074647	
31	32.917	-0.0018200	-1.3439E-6	2	-0.16178	0.093645	
32	32.639	-0.0014540	-1.2785E-6	2	-0.12925	0.10703	
33	32.361	-0.0011153	-1.1529E-6	2	-0.099137	0.11592	
34	32.083	-816.56E-6	-994.46E-9	2	-0.072584	0.12137	

Hampstead - 24-26 Redington Gardens
 450mm diameter
 moment condition - 25kN (SLS) Horizontal

Job No.	Sheet No.	Rev.
21495	D3-A	
Drg. Ref.		
Made by	Date	Checked
DBS		

Node	Level [m]	Defl [mm]	Rotation [rad]	Soil	Pressure [kN/m ²]	Bending [kNm]	Shear [kN]
35	31.806	-563.95E-6	-823.79E-9	2	-0.050129	0.12430	-0.0074159
36	31.528	-358.68E-6	-655.57E-9	2	-0.031882	0.12549	-0.0022902
37	31.250	-198.60E-6	-499.63E-9	2	-0.017654	0.12557	805.75E-6
38	30.972	-79.417E-6	-361.90E-9	2	-0.0070593	0.12504	0.0023503
39	30.694	4.4104E-6	-245.33E-9	2	392.04E-6	0.12427	0.0027670
40	30.417	58.911E-6	-150.73E-9	2	0.0052366	0.12350	0.0024152
41	30.139	90.121E-6	-77.424E-9	2	0.0080108	0.12292	0.0015873
42	29.861	103.75E-6	-23.823E-9	3	0.013833	0.12262	222.02E-6
43	29.583	104.94E-6	12.688E-9	3	0.013992	0.12280	-0.0015170
44	29.306	97.974E-6	35.443E-9	3	0.013063	0.12346	-0.0032080
45	29.028	86.221E-6	47.683E-9	3	0.011496	0.12458	-0.0047429
46	28.750	72.184E-6	52.350E-9	3	0.0096245	0.12610	-0.0060630
47	28.472	57.605E-6	51.974E-9	3	0.0076806	0.12795	-0.0071445
48	28.194	43.585E-6	48.627E-9	3	0.0058113	0.13007	-0.0079878
49	27.917	30.715E-6	43.927E-9	3	0.0040953	0.13239	-0.0086070
50	27.639	19.197E-6	39.059E-9	3	0.0025595	0.13485	-0.0090229
51	27.361	8.9571E-6	34.821E-9	3	0.0011943	0.13740	-0.0092575
52	27.083	-248.42E-9	31.663E-9	3	-33.122E-6	0.13999	-0.0093301
53	26.806	-8.7462E-6	29.723E-9	3	-0.0011662	0.14258	-0.0092551
54	26.528	-16.861E-6	28.859E-9	3	-0.0022481	0.14514	-0.0090417
55	26.250	-24.841E-6	28.661E-9	3	-0.0033121	0.14761	-0.0086942

- The letter "P" next to a result indicates that the effective earth pressure is greater than 0.99 times the passive limit, but within the convergence pressure limit.

EXTREME values so far:-

Deflections		Rotations		Moments		Shears	
Min	Max	Min	Max	Min	Max	Min	Max
[mm]	[mm]	[rad]	[rad]	[kNm]	[kNm]	[kN]	[kN]
-1.8777	0.096778	-887.83E-6	38.390E-6	-15.936	14.249	-37.500	5.5353

RESTRAINT FORCES

No.	Node	Lateral force [kN]	Moment [kNm]
1	1	0.0	15.936

Hampstead - 24-26 Redington Gardens
 450mm diameter
 moment condition - 25kN (SLS) Horizontal

Job No.	Sheet No.	Rev.
21495	D3-B	
Drg. Ref.		
Made by DBS	Date	Checked

Notes

Case D3-B

General Data

Number of increments = 1
 Increment applied loads only

Convergence Control

Maximum number of iterations = 300
 Maximum displacement error [mm] = 0.0010000
 Maximum pressure error [kN/m²] = 0.10000
 Damping coefficient = 1.0000
 Maximum incremental deflection [m] = 2.0000

Soil Data

Elastic-plastic soils
 Factor on soil E value: 0.8000

No.	Level [m]	E [kN/m ²]	Unit wt.	Phi [deg]	Factored K _q	Factored K _c	c(top) [kN/m ²]	dc/dz [kN/m ² /m]
1	43.480000	28800.	20.000	25.000	-	-	0.0	0.0
2	35.000000	50000.	20.000	25.000	-	-	0.0	0.0
3	30.000000	75000.	20.000	25.000	-	-	0.0	0.0

Calculated K_q and K_c Values

Node	Z/D	K _q	K _c
1	0.0	3.2869	5.6339
2	0.89259	4.0391	12.299
3	1.7852	4.6375	16.612
4	2.6778	5.1250	19.632
5	3.5704	5.5296	21.864
6	4.4630	5.8710	23.581
7	5.3556	6.1628	24.942
8	6.2482	6.4152	26.049
9	7.1407	6.6356	26.965
10	8.0333	6.8297	27.738
11	8.9259	7.0019	28.397
12	9.8185	7.1559	28.966
13	10.711	7.2942	29.462
14	11.604	7.4193	29.899
15	12.496	7.5329	30.287
16	13.389	7.6365	30.633
17	14.281	7.7314	30.944
18	15.174	7.8186	31.224
19	16.067	7.8991	31.479
20	16.960	7.9712	31.707
21	17.853	8.0356	31.917
22	18.746	8.0923	32.107
23	19.639	8.1414	32.277
24	20.532	8.1830	32.427
25	21.425	8.2173	32.557
26	22.318	8.2444	32.667
27	23.211	8.2644	32.757
28	24.104	8.2774	32.827
29	24.997	8.2835	32.877
30	25.890	8.2827	32.907
31	26.783	8.2751	32.917
32	27.676	8.2607	32.907
33	28.569	8.2395	32.877
34	29.462	8.2116	32.827
35	30.355	8.1770	32.757
36	31.248	8.1357	32.667
37	32.141	8.0878	32.557
38	33.034	8.0333	32.427
39	33.927	7.9712	32.277
40	34.820	7.9025	32.107
41	35.713	7.8272	31.917
42	36.606	7.7454	31.707
43	37.499	7.6572	31.479
44	38.392	7.5626	31.224
45	39.285	7.4617	30.944
46	40.178	7.3545	30.633

Hampstead - 24-26 Redington Gardens
 450mm diameter
 moment condition - 25kN (SLS) Horizontal

Job No.	Sheet No.	Rev.
21495	D3-B	
Drg. Ref.		
Made by DBS	Date	Checked

Node	Z/D	K _q	K _c
47	33.351	8.7544	33.964
48	33.968	8.7716	34.010
49	34.585	8.7882	34.055
50	35.202	8.8044	34.098
51	35.820	8.8201	34.140
52	36.437	8.8354	34.181
53	37.054	8.8502	34.220
54	37.672	8.8647	34.258
55	38.289	8.8787	34.295

Sections

Name	Input Type	Description	Material	Class	Effective Width	EI
					[m]	[kNm ²]
Section 1	Explicit	Description, Material and Class not applicable			0.45000	40258.

Pile Properties

Level	Section
[m]	
43.480	Section 1

Pile base at 26.250000 m

Applied Loads and Displacements

No.	Level	Force	Moment	Displacement
	[m]	[kN]	[kNm]	[mm]
1	43.480	25.000	0.0	0.0

Restraints

No.	Node	Lateral Stiffness	Rotational Stiffness
		[kN/m]	[kNm/rad]
1	1	0.0	20000.

Surcharges

No.	Level	Pressure
	[m]	[kN/m ²]
1	43.480	10.000

Geometry and Initial state

Node	Level	Soil	EI	Effective Width	Water Pressure	Soil Disp
	[m]		[kNm ²]	[m]	[kN/m ²]	[mm]
1	43.480	1	40258.	0.45000	0.0	0.0
2	43.078	1	40258.	0.45000	3.9404	0.0
3	42.677	1	40258.	0.45000	7.8807	0.0
4	42.275	1	40258.	0.45000	11.821	0.0
5	41.873	1	40258.	0.45000	15.761	0.0
6	41.472	1	40258.	0.45000	19.702	0.0
7	41.070	1	40258.	0.45000	23.642	0.0
8	40.668	1	40258.	0.45000	27.582	0.0
9	40.267	1	40258.	0.45000	31.523	0.0
10	39.865	1	40258.	0.45000	35.463	0.0
11	39.463	1	40258.	0.45000	39.404	0.0
12	39.062	1	40258.	0.45000	43.344	0.0
13	38.660	1	40258.	0.45000	47.284	0.0
14	38.258	1	40258.	0.45000	51.225	0.0
15	37.857	1	40258.	0.45000	55.165	0.0
16	37.455	1	40258.	0.45000	59.105	0.0
17	37.053	1	40258.	0.45000	63.046	0.0
18	36.652	1	40258.	0.45000	66.986	0.0
19	36.250	1	40258.	0.45000	70.926	0.0
20	35.972	1	40258.	0.45000	73.651	0.0
21	35.694	1	40258.	0.45000	76.376	0.0
22	35.417	1	40258.	0.45000	79.101	0.0
23	35.139	1	40258.	0.45000	81.826	0.0
24	34.861	2	40258.	0.45000	84.551	0.0

Hampstead - 24-26 Redington Gardens
 450mm diameter
 moment condition - 25kN (SLS) Horizontal

Job No.	Sheet No.	Rev.
21495	D3-B	
Drg. Ref.		
Made by DBS	Date	Checked

Node	Level	Soil	EI	Effective Width	Water Pressure	Soil Disp
	[m]		[kNm ²]	[m]	[kN/m ²]	[mm]
25	34.583	2	40258.	0.45000	87.276	0.0
26	34.306	2	40258.	0.45000	90.001	0.0
27	34.028	2	40258.	0.45000	92.726	0.0
28	33.750	2	40258.	0.45000	95.451	0.0
29	33.472	2	40258.	0.45000	98.176	0.0
30	33.194	2	40258.	0.45000	100.90	0.0
31	32.917	2	40258.	0.45000	103.63	0.0
32	32.639	2	40258.	0.45000	106.35	0.0
33	32.361	2	40258.	0.45000	109.08	0.0
34	32.083	2	40258.	0.45000	111.80	0.0
35	31.806	2	40258.	0.45000	114.53	0.0
36	31.528	2	40258.	0.45000	117.25	0.0
37	31.250	2	40258.	0.45000	119.98	0.0
38	30.972	2	40258.	0.45000	122.70	0.0
39	30.694	2	40258.	0.45000	125.43	0.0
40	30.417	2	40258.	0.45000	128.15	0.0
41	30.139	2	40258.	0.45000	130.88	0.0
42	29.861	3	40258.	0.45000	133.60	0.0
43	29.583	3	40258.	0.45000	136.33	0.0
44	29.306	3	40258.	0.45000	139.05	0.0
45	29.028	3	40258.	0.45000	141.78	0.0
46	28.750	3	40258.	0.45000	144.50	0.0
47	28.472	3	40258.	0.45000	147.23	0.0
48	28.194	3	40258.	0.45000	149.95	0.0
49	27.917	3	40258.	0.45000	152.68	0.0
50	27.639	3	40258.	0.45000	155.40	0.0
51	27.361	3	40258.	0.45000	158.13	0.0
52	27.083	3	40258.	0.45000	160.85	0.0
53	26.806	3	40258.	0.45000	163.58	0.0
54	26.528	3	40258.	0.45000	166.30	0.0
55	26.250	3	40258.	0.45000	169.03	0.0

Output for load increment 1

Iteration	Max Inc	at node	Disp error	Pressure error
			[mm]	[kN/m ²]
9	1.88	1	0.0007	0.04

Node	Level	Defl	Rotation	Soil Pressure	Bending	Shear	
	[m]	[mm]	[rad]	[kN/m ²]	[kNm]	[kN]	
1	43.480	-1.8777	-796.82E-6	1	-39.471	0.0	P
1	43.480				-15.936	-37.500	
2	43.078	-1.5349	-887.83E-6	1	-56.923	-2.3066	P
3	42.677	-1.1800	-863.50E-6	1	-60.414	7.1904	
4	42.275	-0.85094	-766.33E-6	1	-43.568	12.301	
5	41.873	-0.56906	-633.98E-6	1	-29.136	14.249	
6	41.472	-0.34283	-492.78E-6	1	-17.553	14.081	
7	41.070	-0.17212	-359.65E-6	1	-8.8124	12.639	
8	40.668	-0.051553	-244.13E-6	1	-2.6395	10.558	
9	40.267	0.026917	-150.38E-6	1	1.3782	8.2843	
10	39.865	0.072224	-78.838E-6	1	3.6979	6.1109	
11	39.463	0.092979	-27.679E-6	1	4.7605	4.2061	
12	39.062	0.096778	6.1638E-6	1	4.9550	2.6468	
13	38.660	0.089874	26.210E-6	1	4.6016	1.4474	
14	38.258	0.077107	35.919E-6	1	3.9479	0.58194	
15	37.857	0.061989	38.390E-6	1	3.1738	0.0031477	
16	37.455	0.046891	36.200E-6	1	2.4008	-0.34522	
17	37.053	0.033262	31.369E-6	1	1.7030	-0.51929	
18	36.652	0.021846	25.383E-6	1	1.1185	-0.56972	
19	36.250	0.012888	19.265E-6	1	0.65989	-0.53894	
20	35.972	0.0080968	15.289E-6	1	0.41455	-0.48963	
21	35.694	0.0043599	11.687E-6	1	0.22322	-0.42593	
22	35.417	0.0015624	8.5344E-6	1	0.079993	-0.35447	
23	35.139	-426.46E-6	5.8677E-6	1	-0.021835	-0.28024	
24	34.861	-0.0017431	3.6939E-6	2	-0.15494	-0.20677	
25	34.583	-0.0025223	1.9919E-6	2	-0.22421	-0.13868	
26	34.306	-0.0028892	716.19E-9	2	-0.25682	-0.078371	
27	34.028	-0.0029544	-190.84E-9	2	-0.26261	-0.026981	
28	33.750	-0.0028116	-791.40E-9	2	-0.24992	0.015291	
29	33.472	-0.0025374	-1.1469E-6	2	-0.22554	0.048885	
30	33.194	-0.0021918	-1.3143E-6	2	-0.19483	0.074647	
31	32.917	-0.0018200	-1.3439E-6	2	-0.16178	0.093645	
32	32.639	-0.0014540	-1.2785E-6	2	-0.12925	0.10703	
33	32.361	-0.0011153	-1.1529E-6	2	-0.099137	0.11592	
34	32.083	-816.56E-6	-994.46E-9	2	-0.072584	0.12137	

Hampstead - 24-26 Redington Gardens
 450mm diameter
 moment condition - 25kN (SLS) Horizontal

Job No.	Sheet No.	Rev.
21495	D3-B	
Drg. Ref.		
Made by	Date	Checked
DBS		

Node	Level [m]	Defl [mm]	Rotation [rad]	Soil	Pressure [kN/m ²]	Bending [kNm]	Shear [kN]
35	31.806	-563.95E-6	-823.79E-9	2	-0.050129	0.12430	-0.0074159
36	31.528	-358.68E-6	-655.57E-9	2	-0.031882	0.12549	-0.0022902
37	31.250	-198.60E-6	-499.63E-9	2	-0.017654	0.12557	805.75E-6
38	30.972	-79.417E-6	-361.90E-9	2	-0.0070593	0.12504	0.0023503
39	30.694	4.4104E-6	-245.33E-9	2	392.04E-6	0.12427	0.0027670
40	30.417	58.911E-6	-150.73E-9	2	0.0052366	0.12350	0.0024152
41	30.139	90.121E-6	-77.424E-9	2	0.0080108	0.12292	0.0015873
42	29.861	103.75E-6	-23.823E-9	3	0.013833	0.12262	222.02E-6
43	29.583	104.94E-6	12.688E-9	3	0.013992	0.12280	-0.0015170
44	29.306	97.974E-6	35.443E-9	3	0.013063	0.12346	-0.0032080
45	29.028	86.221E-6	47.683E-9	3	0.011496	0.12458	-0.0047429
46	28.750	72.184E-6	52.350E-9	3	0.0096245	0.12610	-0.0060630
47	28.472	57.605E-6	51.974E-9	3	0.0076806	0.12795	-0.0071445
48	28.194	43.585E-6	48.627E-9	3	0.0058113	0.13007	-0.0079878
49	27.917	30.715E-6	43.927E-9	3	0.0040953	0.13239	-0.0086070
50	27.639	19.197E-6	39.059E-9	3	0.0025595	0.13485	-0.0090229
51	27.361	8.9571E-6	34.821E-9	3	0.0011943	0.13740	-0.0092575
52	27.083	-248.42E-9	31.663E-9	3	-33.122E-6	0.13999	-0.0093301
53	26.806	-8.7462E-6	29.723E-9	3	-0.0011662	0.14258	-0.0092551
54	26.528	-16.861E-6	28.859E-9	3	-0.0022481	0.14514	-0.0090417
55	26.250	-24.841E-6	28.661E-9	3	-0.0033121	0.14761	-0.0086942

- The letter "P" next to a result indicates that the effective earth pressure is greater than 0.99 times the passive limit, but within the convergence pressure limit.

EXTREME values so far:-

Deflections		Rotations		Moments		Shears	
Min	Max	Min	Max	Min	Max	Min	Max
[mm]	[mm]	[rad]	[rad]	[kNm]	[kNm]	[kN]	[kN]
-1.8777	0.096778	-887.83E-6	38.390E-6	-15.936	14.249	-37.500	5.5353

RESTRAINT FORCES

No.	Node	Lateral force	Moment
		[kN]	[kNm]
1	1	0.0	15.936



APPENDIX E

Ref No	Description
E1-A	Results of “ADCOL” analysis for 450mm diameter bearing piles with 6 x B20mm bars, B8mm helical @ 200mm centres, 328kN tension load.
E1-B	Results of “ADCOL” analysis for 450mm diameter bearing piles with 6 x B20mm bars, B8mm helical @ 200mm centres, 735kN compression load.
E1-C	Results of “ADCOL” analysis for 450mm diameter bearing piles with 6 x B20mm bars, B8mm helical @ 200mm centres, 316kN tension load.
E1-D	Results of “ADCOL” analysis for 450mm diameter bearing piles with 6 x B20mm bars, B8mm helical @ 200mm centres, 569kN compression load.
E2-A	Results of “ADCOL” analysis for 450mm diameter bearing piles with 5 x B20mm bars, B8mm helical @ 200mm centres, 325kN tension load.
E2-B	Results of “ADCOL” analysis for 450mm diameter bearing piles with 5 x B20mm bars, B8mm helical @ 200mm centres, 750kN compression load.
E2-C	Results of “ADCOL” analysis for 450mm diameter bearing piles with 5 x B20mm bars, B8mm helical @ 200mm centres, 313kN tension load.
E2-D	Results of “ADCOL” analysis for 450mm diameter bearing piles with 5 x B20mm bars, B8mm helical @ 200mm centres, 574kN compression load.
E3-A	Results of “ADCOL” analysis for 450mm diameter bearing piles with 5 x B20mm bars, B8mm helical @ 200mm centres, 525kN tension load.
E3-B	Results of “ADCOL” analysis for 450mm diameter bearing piles with 5 x B20mm bars, B8mm helical @ 200mm centres, 1106kN compression load.
E3-C	Results of “ADCOL” analysis for 450mm diameter bearing piles with 5 x B20mm bars, B8mm helical @ 200mm centres, 520kN tension load.
E3-D	Results of “ADCOL” analysis for 450mm diameter bearing piles with 5 x B20mm bars, B8mm helical @ 200mm centres, 857kN compression load.
E4-A	Results of “ADCOL” analysis for 450mm diameter bearing piles with 6 x B16mm bars, B8mm helical @ 200mm centres, 388kN tension load.
E4-B	Results of “ADCOL” analysis for 450mm diameter bearing piles with 6 x B16mm bars, B8mm helical @ 200mm centres, 1106kN compression load.
E4-C	Results of “ADCOL” analysis for 450mm diameter bearing piles with 6 x B16mm bars, B8mm helical @ 200mm centres, 382kN tension load.
E4-D	Results of “ADCOL” analysis for 450mm diameter bearing piles with 6 x B16mm bars, B8mm helical @ 200mm centres, 857kN compression load.

Job No.	Sheet No.	Rev.
21495	E1-A	
Drg. Ref.		
Made by DBS	Date 29-Nov-2018	Checked

Reinforcement Details

Bar Arrangement	1 ring(s)/6 bars per ring
Diameter of main bars	20mm
Area of reinforcement	1884.96mm ²
Nominal Cover (outer)	75mm

Design Results

Analysis Case Name	Analysis Case 1
Axial Design Force	-328kN
Axial Capacity	3182.79kN
Design Moment 'M'	0kNm
Ultimate Moment 'Mu'	74.9085kNm
Neutral Axis	— — —
Comp./Tens. Side	+/-
Governing Node/Bar	X

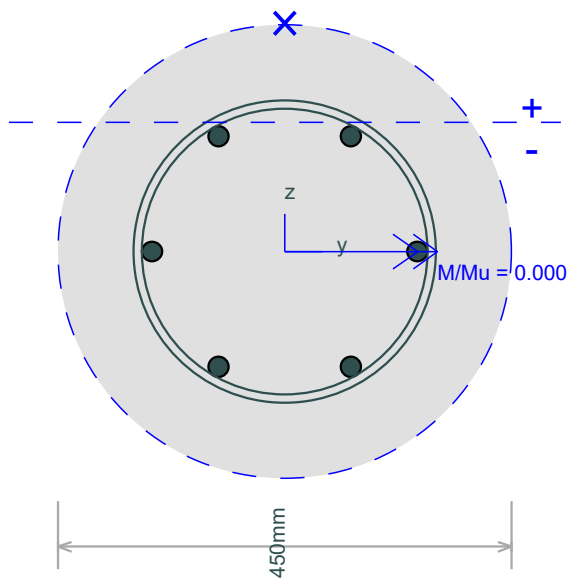
Section 1
 Analysis Case 1

Hampstead - 24-26 Redington Gardens
450mm diameter RW - 6x20mm cage
Moment Check

Job No.	Sheet No.	Rev.
21495	E1-B	
Drg. Ref.		
Made by DBS	Date 29-Nov-2018	Checked

Reinforcement Details

Bar Arrangement	1 ring(s)/6 bars per ring
Diameter of main bars	20mm
Area of reinforcement	1884.96mm ²
Nominal Cover (outer)	75mm

Design Results

Analysis Case Name	Analysis Case 2
Axial Design Force	735kN
Axial Capacity	3182.79kN
Design Moment 'M'	20.7889kNm
Ultimate Moment 'Mu'	155.709kNm
Neutral Axis	— — —
Comp./Tens. Side	+/-
Governing Node/Bar	X

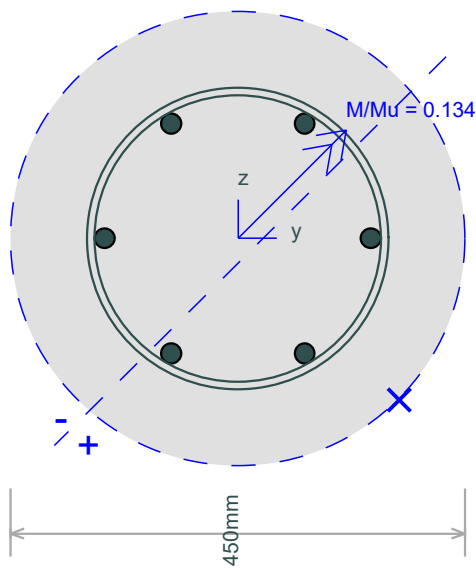

Section 1
Analysis Case 2

Job No.	Sheet No.	Rev.
21495	E1-C	
Drg. Ref.		
Made by DBS	Date 29-Nov-2018	Checked

Reinforcement Details

Bar Arrangement	1 ring(s)/6 bars per ring
Diameter of main bars	20mm
Area of reinforcement	1884.96mm ²
Nominal Cover (outer)	75mm

Design Results

Analysis Case Name	Analysis Case 3
Axial Design Force	-316kN
Axial Capacity	3182.79kN
Design Moment 'M'	0kNm
Ultimate Moment 'Mu'	76.4578kNm
Neutral Axis	— — —
Comp./Tens. Side	+/-
Governing Node/Bar	X

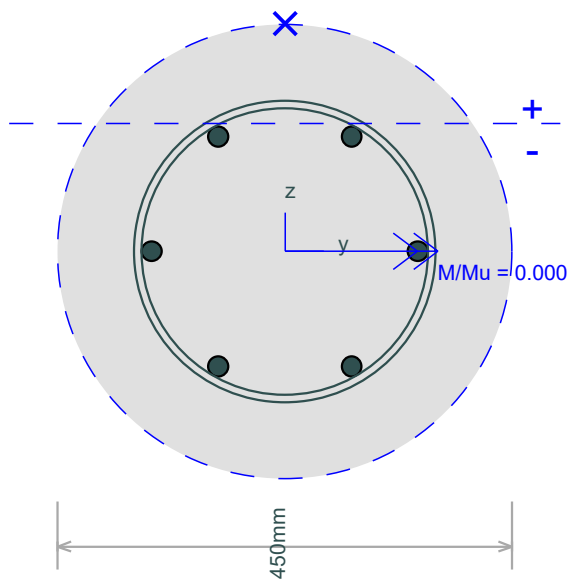

Section 1
 Analysis Case 3

Job No.	Sheet No.	Rev.
21495	E1-D	
Drg. Ref.		
Made by DBS	Date 29-Nov-2018	Checked

Reinforcement Details

Bar Arrangement	1 ring(s)/6 bars per ring
Diameter of main bars	20mm
Area of reinforcement	1884.96mm ²
Nominal Cover (outer)	75mm

Design Results

Analysis Case Name	Analysis Case 4
Axial Design Force	569kN
Axial Capacity	3182.79kN
Design Moment 'M'	16.0938kNm
Ultimate Moment 'Mu'	150.68kNm
Neutral Axis	— — —
Comp./Tens. Side	+/-
Governing Node/Bar	X

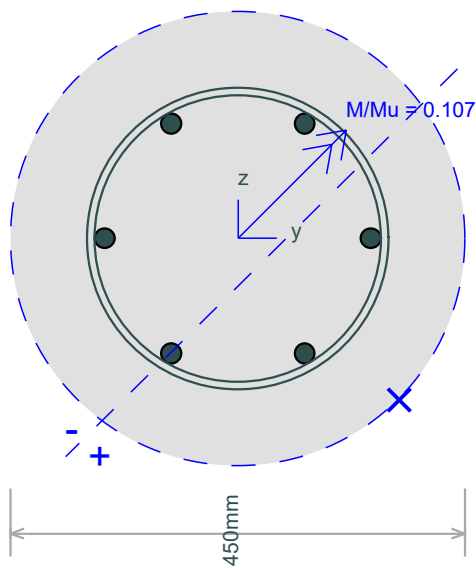

Section 1
Analysis Case 4

Job No.	Sheet No.	Rev.
21495	E2-A	
Drg. Ref.		
Made by DBS	Date 29-Nov-2018	Checked

Reinforcement Details

Bar Arrangement	1 ring(s)/5 bars per ring
Diameter of main bars	20mm
Area of reinforcement	1570.8mm ²
Nominal Cover (outer)	75mm

Design Results

Analysis Case Name	Analysis Case 1
Axial Design Force	-328kN
Axial Capacity	3061.98kN
Design Moment 'M'	0kNm
Ultimate Moment 'Mu'	58.9216kNm
Neutral Axis	— — —
Comp./Tens. Side	+/-
Governing Node/Bar	X

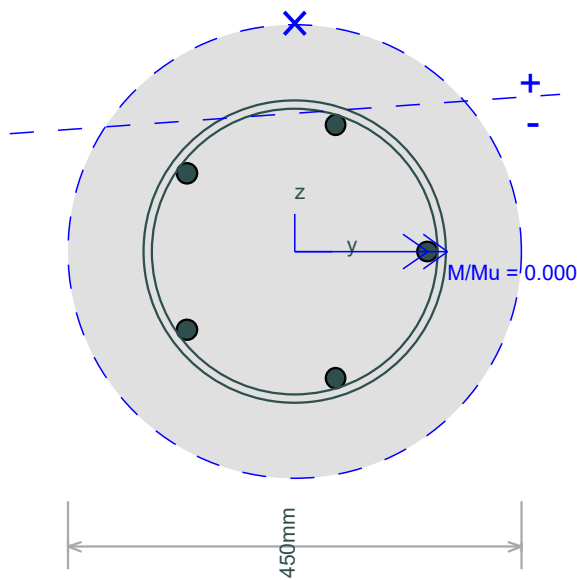

Section 1
Analysis Case 1

Job No.	Sheet No.	Rev.
21495	E2-B	
Drg. Ref.		
Made by DBS	Date 29-Nov-2018	Checked

Reinforcement Details

Bar Arrangement	1 ring(s)/5 bars per ring
Diameter of main bars	20mm
Area of reinforcement	1570.8mm ²
Nominal Cover (outer)	75mm

Design Results

Analysis Case Name	Analysis Case 2
Axial Design Force	735kN
Axial Capacity	3061.98kN
Design Moment 'M'	20.7889kNm
Ultimate Moment 'Mu'	145.476kNm
Neutral Axis	— — —
Comp./Tens. Side	+/-
Governing Node/Bar	X

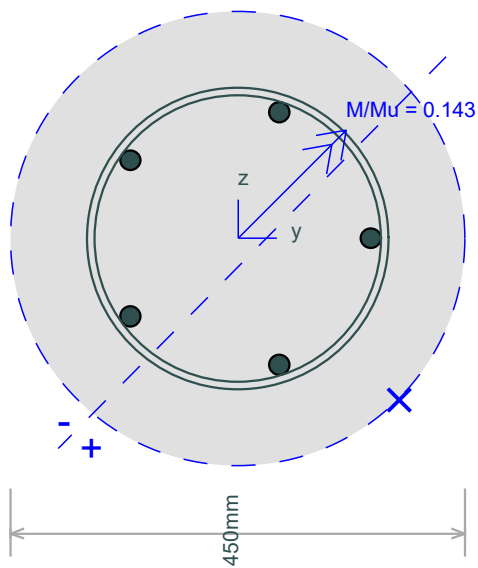
Section 1
 Analysis Case 2

Job No.	Sheet No.	Rev.
21495	E2-C	
Drg. Ref.		
Made by DBS	Date 29-Nov-2018	Checked

Reinforcement Details

Bar Arrangement	1 ring(s)/5 bars per ring
Diameter of main bars	20mm
Area of reinforcement	1570.8mm ²
Nominal Cover (outer)	75mm

Design Results

Analysis Case Name	Analysis Case 3
Axial Design Force	-316kN
Axial Capacity	3061.98kN
Design Moment 'M'	0kNm
Ultimate Moment 'Mu'	60.3718kNm
Neutral Axis	— — —
Comp./Tens. Side	+/-
Governing Node/Bar	X

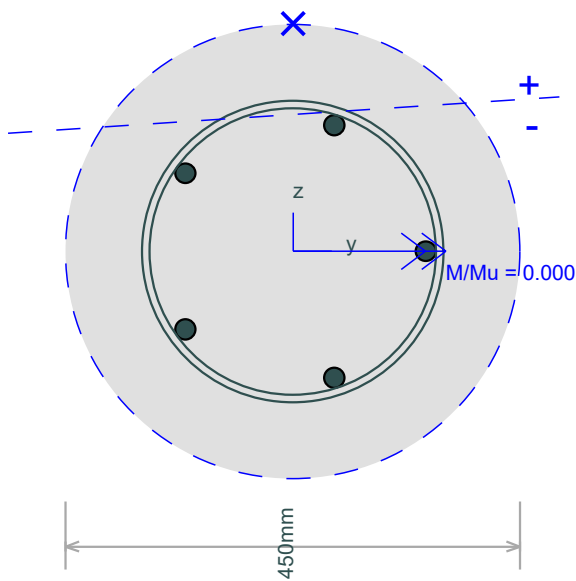

Section 1
 Analysis Case 3

Job No.	Sheet No.	Rev.
21495	E2-D	
Drg. Ref.		
Made by DBS	Date 29-Nov-2018	Checked

Reinforcement Details

Bar Arrangement	1 ring(s)/5 bars per ring
Diameter of main bars	20mm
Area of reinforcement	1570.8mm ²
Nominal Cover (outer)	75mm

Design Results

Analysis Case Name	Analysis Case 4
Axial Design Force	569kN
Axial Capacity	3061.98kN
Design Moment 'M'	16.0938kNm
Ultimate Moment 'Mu'	139.697kNm
Neutral Axis	— — —
Comp./Tens. Side	+/-
Governing Node/Bar	X

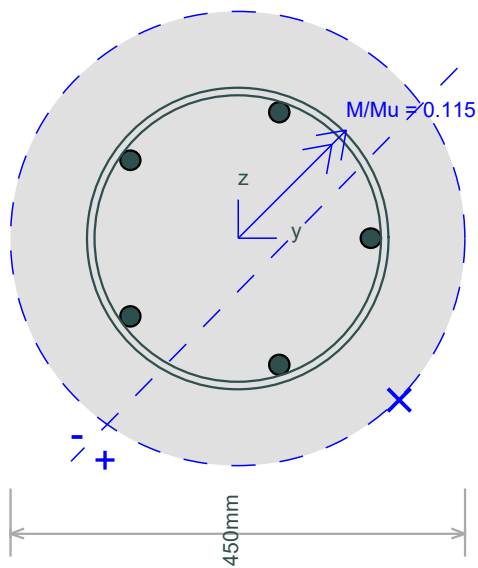

Section 1
Analysis Case 4

Job No.	Sheet No.	Rev.
21495	E3-A	
Drg. Ref.		
Made by DBS	Date 30-Nov-2018	Checked

Reinforcement Details

Bar Arrangement	1 ring(s)/5 bars per ring
Diameter of main bars	20mm
Area of reinforcement	1570.8mm ²
Nominal Cover (outer)	75mm

Design Results

Analysis Case Name	Analysis Case 1
Axial Design Force	-525kN
Axial Capacity	3061.98kN
Design Moment 'M'	0kNm
Ultimate Moment 'Mu'	31.7972kNm
Neutral Axis	— — —
Comp./Tens. Side	+/-
Governing Node/Bar	X

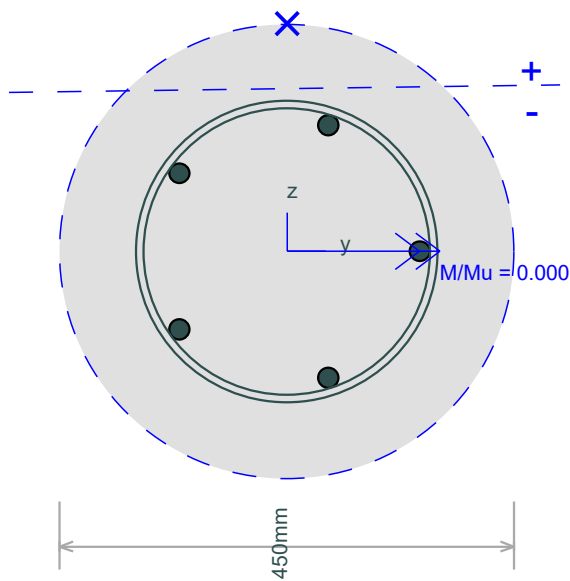

Section 1
Analysis Case 1

Job No.	Sheet No.	Rev.
21495	E3-B	
Drg. Ref.		
Made by DBS	Date 30-Nov-2018	Checked

Reinforcement Details

Bar Arrangement	1 ring(s)/5 bars per ring
Diameter of main bars	20mm
Area of reinforcement	1570.8mm ²
Nominal Cover (outer)	75mm

Design Results

Analysis Case Name	Analysis Case 2
Axial Design Force	1106kN
Axial Capacity	3061.98kN
Design Moment 'M'	31.2824kNm
Ultimate Moment 'Mu'	149.162kNm
Neutral Axis	— — —
Comp./Tens. Side	+/-
Governing Node/Bar	X

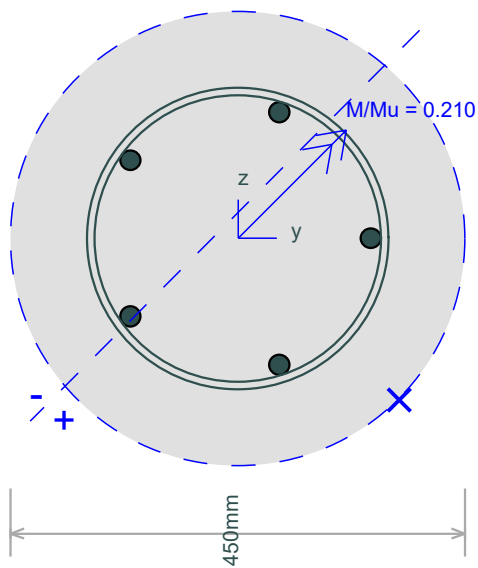

Section 1
Analysis Case 2

Hampstead - 24-26 Redington Gardens
450mm diameter RW - 5x20mm cage
Moment Check

Job No.	Sheet No.	Rev.
21495	E3-C	
Drg. Ref.		
Made by DBS	Date 30-Nov-2018	Checked

Reinforcement Details

Bar Arrangement	1 ring(s)/5 bars per ring
Diameter of main bars	20mm
Area of reinforcement	1570.8mm ²
Nominal Cover (outer)	75mm

Design Results

Analysis Case Name	Analysis Case 3
Axial Design Force	-520kN
Axial Capacity	3061.98kN
Design Moment 'M'	0kNm
Ultimate Moment 'Mu'	32.5356kNm
Neutral Axis	— — —
Comp./Tens. Side	+/-
Governing Node/Bar	X

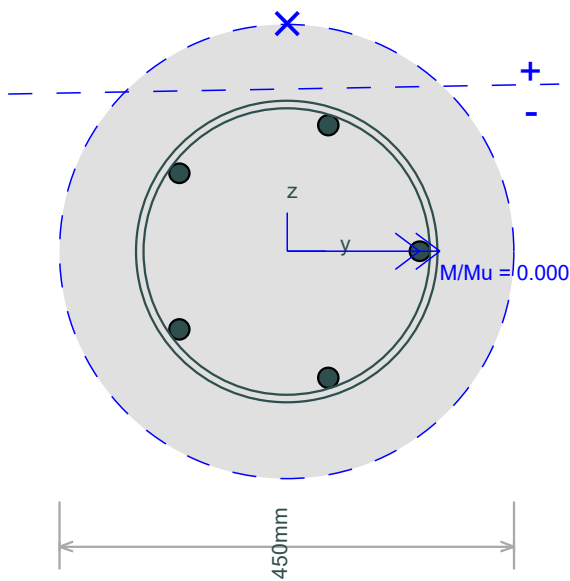

Section 1
Analysis Case 3

Job No.	Sheet No.	Rev.
21495	E3-D	
Drg. Ref.		
Made by DBS	Date 30-Nov-2018	Checked

Reinforcement Details

Bar Arrangement	1 ring(s)/5 bars per ring
Diameter of main bars	20mm
Area of reinforcement	1570.8mm ²
Nominal Cover (outer)	75mm

Design Results

Analysis Case Name	Analysis Case 4
Axial Design Force	857kN
Axial Capacity	3061.98kN
Design Moment 'M'	24.2396kNm
Ultimate Moment 'Mu'	149.142kNm
Neutral Axis	— — —
Comp./Tens. Side	+/-
Governing Node/Bar	X

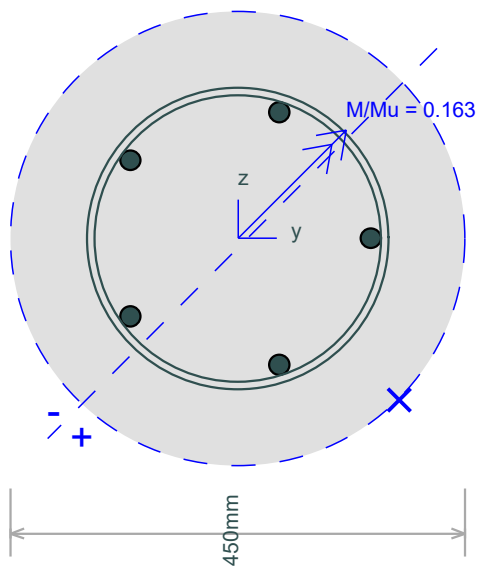
Section 1
 Analysis Case 4

Hampstead - 24-26 Redington Gardens
450mm diameter RW - 6x16mm cage
Moment Check

Job No.	Sheet No.	Rev.
21495	E4-A	
Drg. Ref.		
Made by DBS	Date 30-Nov-2018	Checked

Reinforcement Details

Bar Arrangement	1 ring(s)/6 bars per ring
Diameter of main bars	16mm
Area of reinforcement	1206.37mm ²
Nominal Cover (outer)	75mm

Design Results

Analysis Case Name	Analysis Case 1
Axial Design Force	-388kN
Axial Capacity	2921.84kN
Design Moment 'M'	0kNm
Ultimate Moment 'Mu'	28.2344kNm
Neutral Axis	— — —
Comp./Tens. Side	+/-
Governing Node/Bar	X

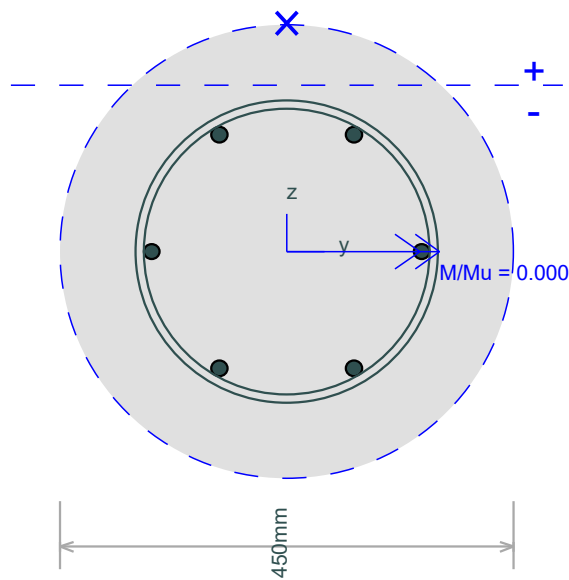

Section 1
Analysis Case 1

Hampstead - 24-26 Redington Gardens
 450mm diameter RW - 6x16mm cage
 Moment Check

Job No.	Sheet No.	Rev.
21495	E4-B	
Drg. Ref.		
Made by DBS	Date 30-Nov-2018	Checked

Reinforcement Details

Bar Arrangement	1 ring(s)/6 bars per ring
Diameter of main bars	16mm
Area of reinforcement	1206.37mm ²
Nominal Cover (outer)	75mm

Design Results

Analysis Case Name	Analysis Case 2
Axial Design Force	1106kN
Axial Capacity	2921.84kN
Design Moment 'M'	31.2824kNm
Ultimate Moment 'Mu'	141.225kNm
Neutral Axis	— — —
Comp./Tens. Side	+/-
Governing Node/Bar	X

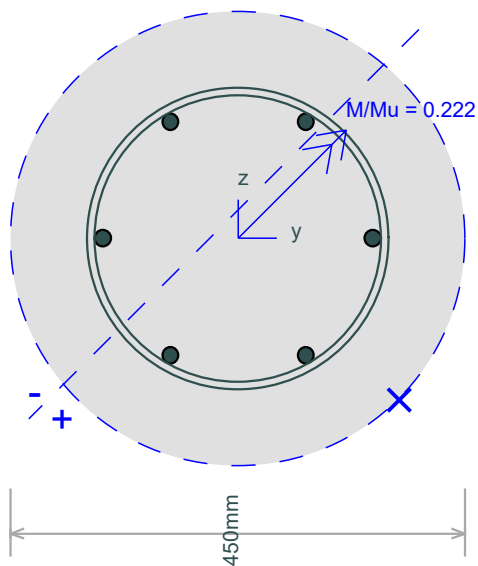

Section 1
 Analysis Case 2

Job No.	Sheet No.	Rev.
21495	E4-C	
Drg. Ref.		
Made by DBS	Date 30-Nov-2018	Checked

Reinforcement Details

Bar Arrangement	1 ring(s)/6 bars per ring
Diameter of main bars	16mm
Area of reinforcement	1206.37mm ²
Nominal Cover (outer)	75mm

Design Results

Analysis Case Name	Analysis Case 3
Axial Design Force	-382kN
Axial Capacity	2921.84kN
Design Moment 'M'	0kNm
Ultimate Moment 'Mu'	29.3411kNm
Neutral Axis	— — —
Comp./Tens. Side	+/-
Governing Node/Bar	X

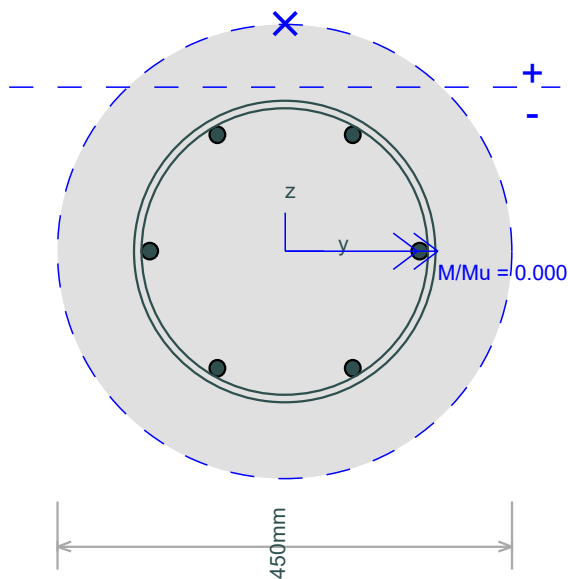

Section 1
Analysis Case 3

Hampstead - 24-26 Redington Gardens
450mm diameter RW - 6x16mm cage
Moment Check

Job No.	Sheet No.	Rev.
21495	E4-D	
Drg. Ref.		
Made by DBS	Date 30-Nov-2018	Checked

Reinforcement Details

Bar Arrangement	1 ring(s)/6 bars per ring
Diameter of main bars	16mm
Area of reinforcement	1206.37mm ²
Nominal Cover (outer)	75mm

Design Results

Analysis Case Name	Analysis Case 4
Axial Design Force	857kN
Axial Capacity	2921.84kN
Design Moment 'M'	24.2396kNm
Ultimate Moment 'Mu'	140.174kNm
Neutral Axis	— — —
Comp./Tens. Side	+/-
Governing Node/Bar	X

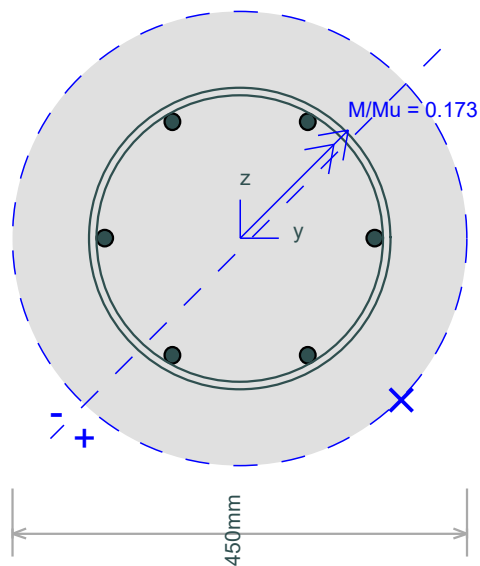

Section 1
Analysis Case 4



- E5 Results of Helical Check for 450mm diameter wall piles with 6 x B20mm bars, B8mm helical @ 225mm centres, 75mm cover (60kN Horizontal).
- E6 Results of Helical Check for 450mm diameter wall piles with 5 x B20mm bars, B8mm helical @ 225mm centres, 75mm cover (50kN Horizontal).
- E7 Results of Helical Check for 450mm diameter wall piles with 5 x B20mm bars, B8mm helical @ 225mm centres, 75mm cover (25kN Horizontal).
- E8 Results of Helical Check for 450mm diameter wall piles with 6 x B16mm bars, B8mm helical @ 225mm centres, 75mm cover (25kN Horizontal).

Project	HAMPSTEAD - 24-26 Redington Gardens	Project No.	21495	Date	03/12/2018
Titile	450mm Pile Shear Check - Bearing Piles	By	DBS	Check By	Page 1

REFERENCE
EC2
Shear to EN 1992-1-1:2004 (EC2) Circular Sections (Cast In-situ) using helical reinforcement
Pile section

4.4.1.3(4)	pile dia d_{nom} =	450 mm		
	design pile diameter =	450 mm		
	A_c =	159043 mm ²		
	cover c_{nom} =	75 mm	$k_2 =$	75 mm [NA.1 4.4.1.3 (4)]
	main bar dia =	20 mm		
	no. main bars =	6 no.		
	helical dia. =	8 mm		
	d =	303 mm	$\gamma_c =$	1.5 (This is adjusted by $K_f=1.1$ [2.4.2.5 (2)] to give 1.65)
	f_{ck} =	30 MPa	$\gamma_c =$	1.65 $\alpha_{cc} =$
	f_{yk} =	500 MPa	$\gamma_s =$	1.15 [NA.1 3.1.6 (1)]
	Ult V_{Ed} =	90 kN	SF factor	1
	Ult V_{Ed} =	90 kN		
	factored action: N_{Ed} =	-328 kN		

6.2.2

Check requirement for shear reinforcement

$V_{Rd,c}$ =	$[C_{Rd,c}k(100\rho_1f_{ck})^{1/3}+k_1\sigma_{cp}]b_wd$	$CR_{d,c}$ =	$0.18 / \gamma_c$	0.11
with minimum	$= (v_{min}+k_1\sigma_{cp})b_wd$	k =	$1+(200/d)^{1/2}$	1.81 ≤ 2.0
v_{min} =	$0.035k^{3/2}f_{ck}^{1/2}$	ρ_1 =	A_{sl}/b_wd	0.01 ≤ 0.02
	0.4679	σ_{cp} =	N_{ed}/A_c	-2.06 $< 0.2f_{cd}$
		k_1 =	0.15	[NA.1 6.2.2(1)]

$$V_{Rd,c} = 22 \text{ kN}$$

Is $V_{Rd,c} > V_{Ed}$ \Rightarrow **NO** Action: **Design of shear reinforcement required**

6.2.3

Design Shear Reinforcement

Check concrete strut capacity at $\cot \theta = 2.5$:-

6.2.3 (3) exp 6.9	$V_{Rd,max}$ =	$\alpha_{cw} \cdot b_w \cdot z \cdot v_1 \cdot f_{cd} / (\cot \theta + \tan \theta)$ (6.9)	$\cot \theta$ =	1
			$\tan \theta$ =	1
	$V_{Rd,max}$ =	500 kN	α_{cw} =	1 [NA.1 6.2.3(3)]
			z =	0.9d 272 mm
			v_1 =	0.6 (1-($f_{ck}/250$)) 0.53 [6.6N]

Is $V_{Rd,c} > V_{Ed}$ \Rightarrow **YES** Action: **Calculate link spacing**

Calculation for strut inclination:-

θ =	$0.5 \cdot \sin^{-1}[(6.54 \cdot V_{Ed}) / (b_w \cdot d \cdot (1 - f_{ck}/250) \cdot f_{ck})]$	$\cot \theta$ =	2.5 > 1.0
θ =	NA rad		

Calculate shear reinforcement spacing after Turmo et al (2008):-

$V_{Rd,s}$ =	$z \cdot \cot \theta \cdot (A_\phi / 0.5s) \cdot f_{ywd} \cdot 0.85$	A_ϕ =	50.3 mm ²
s =	$2 \cdot ([z \cdot \cot \theta \cdot A_\phi \cdot f_{ywd} \cdot 0.85] / V_{Rd,s})$	f_{ywd} =	435 MPa
	281 mm		

Provide 8 mm helical at nominal pitch 225 mm

Project	HAMPSTEAD - 24-26 Redington Gardens	Project No.	21495	Date	03/12/2018
Tilte	450mm Pile Shear Check - Bearing Piles	By	DBS	Check By	Page 1

REFERENCE
EC2
Shear to EN 1992-1-1:2004 (EC2) Circular Sections (Cast In-situ) using helical reinforcement
Pile section

4.4.1.3(4)	pile dia d_{nom} =	450 mm		
	design pile diameter =	450 mm		
	A_c =	159043 mm ²		
	cover c_{nom} =	75 mm	$k_2 =$	75 mm [NA.1 4.4.1.3 (4)]
	main bar dia =	20 mm		
	no. main bars =	5 no.		
	helical dia. =	8 mm		
	d =	303 mm	$\gamma_c =$	1.5 (This is adjusted by $K_f=1.1$ [2.4.2.5 (2)] to give 1.65)
	f_{ck} =	30 MPa	$\gamma_c =$	1.65 $\alpha_{cc} =$
	f_{yk} =	500 MPa	$\gamma_s =$	1.15 0.85 [NA.1 3.1.6 (1)]
	Ult V_{Ed} =	75 kN	SF factor	1
	Ult V_{Ed} =	75 kN		
	factored action: N_{Ed} =	-325 kN		

6.2.2

Check requirement for shear reinforcement

$V_{Rd,c}$ =	$[C_{Rd,c}k(100\rho_1f_{ck})^{1/3}+k_1\sigma_{cp}]b_wd$	$CR_{d,c}$ =	$0.18 / \gamma_c$	0.11
with minimum =	$(v_{min}+k_1\sigma_{cp})b_wd$	k =	$1+(200/d)^{1/2}$	1.81 ≤ 2.0
v_{min} =	$0.035k^{3/2}f_{ck}^{1/2}$	ρ_1 =	A_s/b_wd	0.01 ≤ 0.02
	0.4679	σ_{cp} =	N_{ed}/A_c	-2.04 $< 0.2f_{cd}$
		k_1 =	0.15	[NA.1 6.2.2(1)]

$$V_{Rd,c} = 22 \text{ kN}$$

Is $V_{Rd,c} > V_{Ed}$ \Rightarrow **NO** Action: **Design of shear reinforcement required**

6.2.3

Design Shear Reinforcement

 Check concrete strut capacity at $\cot \theta = 2.5$:-

6.2.3 (3) exp 6.9	$V_{Rd,max}$ =	$\alpha_{cw} \cdot b_w \cdot z \cdot v_1 \cdot f_{cd} / (\cot \theta + \tan \theta)$ (6.9)	$\cot \theta$ =	1
			$\tan \theta$ =	1
	$V_{Rd,max}$ =	500 kN	α_{cw} =	1 [NA.1 6.2.3(3)]
			z =	0.9d 272 mm
			v_1 =	0.6 (1-($f_{ck}/250$)) 0.53 [6.6N]

Is $V_{Rd,c} > V_{Ed}$ \Rightarrow **YES** Action: **Calculate link spacing**

Calculation for strut inclination:-

θ =	$0.5 \cdot \sin^{-1} [(6.54 \cdot V_{Ed}) / (b_w \cdot d \cdot (1 - f_{ck}/250) \cdot f_{ck})]$	$\cot \theta$ =	2.5 > 1.0
θ =	NA rad		

Calculate shear reinforcement spacing after Turmo et al (2008):-

$V_{Rd,s}$ =	$z \cdot \cot \theta \cdot (A_\phi / 0.5s) \cdot f_{ywd} \cdot 0.85$	A_ϕ =	50.3 mm ²
s =	$2 \cdot ([z \cdot \cot \theta \cdot A_\phi \cdot f_{ywd} \cdot 0.85] / V_{Rd,s})$	f_{ywd} =	435 MPa
	337 mm		

Provide 8 mm helical at nominal pitch 225 mm
--

Project	HAMPSTEAD - 24-26 Redington Gardens	Project No.	21495	Date	03/12/2018
Titile	450mm Pile Shear Check - Bearing Piles	By	DBS	Check By	Page 1

REFERENCE
EC2
Shear to EN 1992-1-1:2004 (EC2) Circular Sections (Cast In-situ) using helical reinforcement
Pile section

4.4.1.3(4)	pile dia d_{nom} =	450 mm		
	design pile diameter =	450 mm		
	A_c =	159043 mm ²		
	cover c_{nom} =	75 mm	$k_2 =$	75 mm [NA.1 4.4.1.3 (4)]
	main bar dia =	20 mm		
	no. main bars =	5 no.		
	helical dia. =	8 mm		
	d =	303 mm	$\gamma_c =$	1.5 (This is adjusted by $K_f=1.1$ [2.4.2.5 (2)] to give 1.65)
	f_{ck} =	30 MPa	$\gamma_c =$	1.65 $\alpha_{cc} =$
	f_{yk} =	500 MPa	$\gamma_s =$	1.15
	Ult V_{Ed} =	38 kN	SF factor	1
	Ult V_{Ed} =	38 kN		
	factored action: N_{Ed} =	-525 kN		

6.2.2

Check requirement for shear reinforcement

$V_{Rd,c}$ =	$[C_{Rd,c}k(100\rho_1f_{ck})^{1/3}+k_1\sigma_{cp}]b_wd$	$CR_{d,c}$ =	$0.18 / \gamma_c$	0.11
with minimum =	$(v_{min}+k_1\sigma_{cp})b_wd$	k =	$1+(200/d)^{1/2}$	1.81 ≤ 2.0
v_{min} =	$0.035k^{3/2}f_{ck}^{1/2}$	ρ_1 =	A_{sl}/b_wd	0.01 ≤ 0.02
	0.4679	σ_{cp} =	N_{ed}/A_c	-3.3 $< 0.2f_{cd}$
		k_1 =	0.15	[NA.1 6.2.2(1)]

$$V_{Rd,c} = -4 \text{ kN}$$

 Is $V_{Rd,c} > V_{Ed}$ \Rightarrow **NO** Action: **Design of shear reinforcement required**

6.2.3

Design Shear Reinforcement

 Check concrete strut capacity at $\cot \theta = 2.5$:-

 6.2.3 (3)
exp 6.9

$V_{Rd,max}$ =	$\alpha_{cw} \cdot b_w \cdot z \cdot V_1 \cdot f_{cd} / (\cot \theta + \tan \theta)$	(6.9)	$\cot \theta$ =	1
			$\tan \theta$ =	1
			α_{cw} =	1 [NA.1 6.2.3(3)]
			z =	0.9d
$V_{Rd,max}$ =	500 kN		V_1 =	0.6 (1-($f_{ck}/250$))
				0.53 [6.6N]

 Is $V_{Rd,c} > V_{Ed}$ \Rightarrow **YES** Action: **Calculate link spacing**

Calculation for strut inclination:-

θ =	$0.5 \cdot \sin^{-1}[(6.54 \cdot V_{Ed}) / (b_w \cdot d \cdot (1 - f_{ck}/250) \cdot f_{ck})]$	$\cot \theta$ =	2.5	> 1.0
θ =	NA rad			

Calculate shear reinforcement spacing after Turmo et al (2008):-

$V_{Rd,s}$ =	$z \cdot \cot \theta \cdot (A_\phi / 0.5s) \cdot f_{ywd} \cdot 0.85$	A_ϕ =	50.3 mm ²
s =	$2 \cdot ([z \cdot \cot \theta \cdot A_\phi \cdot f_{ywd} \cdot 0.85] / V_{Rd,s})$	f_{ywd} =	435 MPa
	666 mm		

Provide 8 mm helical at nominal pitch	225 mm
---------------------------------------	--------

Project	HAMPSTEAD - 24-26 Redington Gardens	Project No.	21495	Date	03/12/2018
Tilte	450mm Pile Shear Check - Bearing Piles	By	DBS	Check By	Page 1

REFERENCE
EC2
Shear to EN 1992-1-1:2004 (EC2) Circular Sections (Cast In-situ) using helical reinforcement
Pile section

4.4.1.3(4)	pile dia d_{nom} =	450 mm		
	design pile diameter =	450 mm		
	A_c =	159043 mm ²		
	cover c_{nom} =	75 mm	$k_2 =$	75 mm [NA.1 4.4.1.3 (4)]
	main bar dia =	16 mm		
	no. main bars =	6 no.		
	helical dia. =	8 mm		
	d =	305 mm	$\gamma_c =$	1.5 (This is adjusted by $K_f=1.1$ [2.4.2.5 (2)] to give 1.65)
	f_{ck} =	30 MPa	$\gamma_c =$	1.65 $\alpha_{cc} =$
	f_{yk} =	500 MPa	$\gamma_s =$	1.15
	Ult V_{Ed} =	38 kN	SF factor =	1
	Ult V_{Ed} =	38 kN		
	factored action: N_{Ed} =	-388 kN		

6.2.2

Check requirement for shear reinforcement

$V_{Rd,c}$ =	$[C_{Rd,c}k(100\rho_1f_{ck})^{1/3}+k_1\sigma_{cp}]b_wd$	$CR_{d,c}$ =	$0.18 / \gamma_c$	0.11
with minimum =	$(v_{min}+k_1\sigma_{cp})b_wd$	k =	$1+(200/d)^{1/2}$	1.81 ≤ 2.0
v_{min} =	$0.035k^{3/2}f_{ck}^{1/2}$	ρ_1 =	A_s/b_wd	0 ≤ 0.02
	0.4666	σ_{cp} =	N_{ed}/A_c	-2.44 $< 0.2f_{cd}$
		k_1 =	0.15	[NA.1 6.2.2(1)]

$$V_{Rd,c} = 14 \text{ kN}$$

 Is $V_{Rd,c} > V_{Ed}$ \Rightarrow **NO** Action: **Design of shear reinforcement required**

6.2.3

Design Shear Reinforcement

 Check concrete strut capacity at $\cot \theta = 2.5$:-

 6.2.3 (3)
exp 6.9

$V_{Rd,max}$ =	$\alpha_{cw} \cdot b_w \cdot z \cdot V_1 \cdot f_{cd} / (\cot \theta + \tan \theta)$	(6.9)	$\cot \theta =$	1
			$\tan \theta =$	1
			$\alpha_{cw} =$	1 [NA.1 6.2.3(3)]
			$z =$	0.9d
$V_{Rd,max}$ =	504 kN		$V_1 =$	0.6 (1-($f_{ck}/250$))
				0.53 [6.6N]

 Is $V_{Rd,c} > V_{Ed}$ \Rightarrow **YES** Action: **Calculate link spacing**

Calculation for strut inclination:-

$\theta =$	$0.5 \cdot \sin^{-1} [(6.54 \cdot V_{Ed}) / (b_w \cdot d \cdot (1 - f_{ck}/250) \cdot f_{ck})]$	$\cot \theta =$	2.5	> 1.0
$\theta =$	NA rad			

Calculate shear reinforcement spacing after Turmo et al (2008):-

$V_{Rd,s}$ =	$z \cdot \cot \theta \cdot (A_\phi / 0.5s) \cdot f_{ywd} \cdot 0.85$	$A_\phi =$	50.3 mm ²
s =	$2 \cdot ([z \cdot \cot \theta \cdot A_\phi \cdot f_{ywd} \cdot 0.85] / V_{Rd,s})$	$f_{ywd} =$	435 MPa
	671 mm		

Provide 8 mm helical at nominal pitch	225 mm
---------------------------------------	--------