eight
associates

Eight Associates
5th Floor
57a Great Suffolk Street
London
SE1 0BB

+44 (0) 20 7043 0418

www.eightassociates.co.uk
info@eightassociates.co.uk

24 Heath Drive Arboricultural Method Statement

Prepared by:

Stacey Cougill
Eight Associates
5th Floor
57a Great Suffolk Street
London, SE1 0BB

email:

stacey@eightassociates.co.uk

Our Ref:

1948 24 Heath Drive AMS 1905-
20sc.docx

Date of Issue:

Issue 5: 20.05.2019

Prepared for:

Studio Kyson
28 Scrutton Street,
London,
EC2A 4RP

Issue Status

24 Heath Drive

Prepared on behalf of Eight Associates by
Stacey Cougill
Position: Ecologist
Signature: SC

Verified by
Joanna Peacock
Position: Associate
Signature: JEP

DISCLAIMER

This report is made on behalf of Eight Associates. By receiving the report and acting on it, the client - or any third party relying on it - accepts that no individual is personally liable in contract, tort or breach of statutory duty (including negligence).

Contents:	Introduction.....3
	Contact Details4
	General Site Conditions and Tree Protection Measures5
	Supervision and Monitoring7
	Schedule of Tree Works8
	Sequence of Events9
	Appendix 1: Specification and Design of Protective Barriers10
	Appendix 2: Installation of Ground Protection.....13
	Appendix 3: Example Site Monitoring Form15
	Appendix 4: Limitations16

Introduction

24 Heath Drive

Introduction

Eight Associates Ltd has been instructed by Studio Kyson to carry out an Arboricultural Method Statement (AMS) in relation to investigatory works, such as trial pits and boreholes.

The Arboricultural Method Statement (AMS) is a methodology for the implementation of any aspect of development as proposed that has the potential to result in loss of or damage to a tree identified as suitable to be retained.

The AMS takes into consideration construction operations undertaken in the vicinity of the trees. It will deal with such issues as site access, intensity of construction activity, space needed for works, location of materials and location of service runs.

This AMS includes with it a Tree Protection Plan (TPP). The TPP outlines trees to be retained, removed, location of barriers and type of barrier to be installed. This method statement contains a timetable indicating when and how specific works adjacent to trees should be carried out.

This report does not deal with issues relating to subsidence or heave either as a result of retention or removal of trees. It does not consider the water demands of the trees present to enable decisions as to foundation type and depth. This can be done if so required.

Current or proposed structures in relation to the indirect influence of trees are not considered within the report unless directly instructed. It is considered that such considerations are best dealt with in a different report having liaised with the structural engineer.

Contact Details

24 Heath Drive

Ecologist's Details	
Company Name	Eight Associates
Company Address	57a Great Suffolk Street, London, SE1 0BB
Contact Name	Stacey Cougill
Contact Telephone Number	020 7043 0418
Tree Survey Report Reference	1948 24 Heath Drive AMS 1905-20sc.docx
Developer / Client Details	
Company Name	Studio Kyson
Company Address	28 Scrutton Street, London, EC2A 4RP
Contact Name	Rebecca Mak
Contact Telephone Number	020 7247 2462
Development Details	
Development Name	24 Heath Drive
Development Address	24 Heath Drive, London, NW3 7SB

General Site Conditions and Tree Protection Measures

24 Heath Drive

General Site Mitigation Requirements

Storage of Materials

Designated area(s) for temporary storage of materials and site office will be decided by the Site Manager before any works can commence. Suggested suitable areas are marked out on the Tree Protection Plan (TPP). It is advisable to consult with the Arboriculturist if the storage areas or site office deviates from that area as outlined on the TPP.

Fires

There will be no fires or burning of waste materials on site.

Discharge of Contaminants

No materials that are likely to have an adverse effect on tree health, such as oil, bitumen or cement will be discharged within the RPA of any of the trees to be retained. It is advised that the disposal of all waste materials is carried out in an appropriately sustainable fashion.

Contingency Plans

Should there be any contamination of soils either within or adjacent to the RPA these should be dealt with as quickly as possible with a proprietary emergency clean up kit. The situation should then be assessed as to whether it is appropriate to remove soils. An Arboriculturist should be consulted before a decision is made.

The protection barriers erected should be able to be removed relatively easily to access the area in event of an emergency.

Access to the area of proposed works

Access to the site is assumed to be from the existing entrance on to the driveway of the property. Recommendations for cutting back of hedges to improve sight-lines and access is suggested within the schedule of tree works. It is considered that these would be the only access points into the site for the purposes of development. If there are any other proposed access points into the site, this should be agreed prior to use with the Arboriculturist. It is assumed that the existing hard stand will be sufficient to withstand the weight of all machinery associated with the build. If it is considered that the existing hard stand will not bear the weight of construction machinery/activity it will be necessary to use ground protection over the entire area. (it is considered that the driveway will probably only tolerate vehicle weights up to 7.5 tons). Ground protection is required over the existing shrub bed. Interlocking temporary road way maybe used.

The specification of the ground protection must be suitable to accommodate

1. The weight of delivery vehicles,
2. In areas where spillages could occur, harmful to soils and root systems, the ground protection should include a non- permeable material layer. This may be laid beneath the main ground protection if the main ground protection system utilises offers better traction (or is non- slip).

Position of all recommended ground protection is provided within the accompanying Tree Protection Plan.

General Site Conditions and Tree Protection Measures

24 Heath Drive

General Site Mitigation Requirements

Utility Service Provision

All excavations for pipework and inspection chambers should be conducted in accordance with the National Joint Utilities Group (2007) Publication Volume 4: Issue 2 Guidelines for the planning, installation and maintenance of utility apparatus in proximity to trees.

Please note that if trenching is to be carried out within the RPA of a retained tree Arboricultural advice must be sought to ensure that minimum impact is caused to the rooting area. In this instance areas should be cleared with the use of an air spade to reveal existing roots. Where possible thrust boring techniques should be used to install underground services, rather than traditional digging. Where boring is not possible, trenches must be hand excavated taking care not to cut, sever or damage large groups of roots (regardless of the stem diameter), or any roots exceeding 25mm in diameter. Trenches dug must not leave roots exposed and it is recommended that they are wrapped with a hydro-gel and geo-textile membrane.

Cranes and Lifting Equipment

All lifting equipment, including cranes should be so positioned that they operate without contact with the retained trees. Care must be taken so that the arc of the boom fitted to the lifting equipment is sufficiently clear of the retained trees.

Boundaries/ Scope of the Site

The appointed Arboricultural Supervisor must be consulted if the site boundaries of the site are extended or if excavations/ storage/ construction related to this development is to be carried out on other parts of the site, outside of the development site as indicated on the Tree Protection Plan.

Supervision and Monitoring 24 Heath Drive

Monitoring and Supervision

All required Arboricultural supervisory works and monitoring visits must be confirmed by formal correspondence circulated to all relevant parties, including the council. These records of site visits will provide proof of compliance. The 'Sequence of Events' section below lists and details the events in relation to trees that require Arboricultural involvement.

Recommendations for site monitoring and supervision

A pre-commencement meeting should be held on site before any of the tree work, demolition and construction work begins. This should be attended by the Site Manager and the Arboricultural consultant. The Arboricultural consultant will inform the council in writing of the details of meetings. All tree protection measures detailed in this document must be discussed so that they are fully understood by all the parties. Clarification or modifications to the consented details must be recorded and circulated to all parties in writing. These documents should then form the basis of any supervision arrangements between the Arboricultural consultant and the proposer, as agreed with the Local Planning Authority where applicable.

The Arboricultural consultant will visit during the phases as set out in the 'Sequence of Events' section below. The consultant's role is to advise on the development in relation to the trees, as well as liaise as necessary between the developer/ site manager and the local planning authority to ensure that appropriate protection measures are in place. The role will involve monitoring compliance with Arboricultural conditions (where applied) and advising on any tree problems as they arise. A development site monitoring form (please see Appendices for example), will be completed by the supervising Arboriculturist during each site visit, to include the following;

1. Date of visit.
2. List of those in attendance on site.
3. Findings in relation to trees.
4. Details of any non-compliance.
5. Recommendations to be actioned so that the non-compliance is addressed and remedied.
6. List of the parties concerned to whom the monitoring sheet has been sent.
7. Date that Monitoring sheet emailed/ posted to the recipients.

Site Management:

It is the Site Manager's responsibility to ensure that the requirements set out within the Arboricultural Method Statement are known and understood by all site personnel. Copies of pertinent documents should be kept on site at all times. The site manager will brief all personnel who may have an impact on any trees and relay specific tree protection requirements. This methodology should be a part of all site induction procedures and written into appropriate site management documents. The following pertinent points should be explained to all personnel who could have an impact on trees;

1. The specification of the Protective Barriers around retained trees.
2. The requirement for Protective Barriers to be sufficiently robust to prevent incursion by construction activity.
3. Why it is essential that the Protective Barriers remain throughout the works.
4. The importance of the 'exclusion zones' around retained trees.
5. The potential damage caused to trees by compaction of soils.

Schedule of Tree Works

24 Heath Drive

Tree (& related) works to be carried out prior to installation of protective Barriers

Following tree works will need to be carried out prior to the installation of protective barriers.

Tree Number	Species	Works Required
H1	Privet	Fell and remove/grind stumps.
H2	Privet	Fell and remove/grind stumps.
T3	Oak	Fell and remove stump
T4	Elder	Fell and remove stump
T5	Elder	Fell and remove stump
T6	Pyracantha	Fell and remove stump
T7	Pyracantha	Fell and remove stump
T8	Goat Willow	Fell and remove stump
T9	Elder	Fell and remove stump
T10	Birch	Fell and remove stump
T11	Cherry	Fell and remove stump
T12	Cherry	Fell and remove stump
T13	Rhododendron	Fell and remove stump
T14	Cherry	Fell and remove stump
T15	Yew	Fell and remove stump
T16	Yew	Fell and remove stump
T17	Oak	Fell and remove/grind stump
T18	Sycamore	Fell and remove stump
T19	Crab Apple	Fell and remove stump
T23	Lime	Crown lift to a height of 4m retaining major laterals. Crown reduce by 2m to NW and SE and 1m to NE and SW. Crown clean.
T24	Lime	Crown lift to a height of 4m retaining major laterals. Crown reduce by 2m to N, W and S to balance crown. Crown clean.
T25	Oak	Fell and remove/grind stump
G1	Group	Fell and remove/grind stump

Tree works to be carried out post-construction

It is currently considered that there will be no requirement for tree works post construction. This should be reviewed by the Arboriculturist post construction.

Variations

Any variations to the tree protection measures will need to be agreed in writing by the Local Planning Authority before implementation. The variation will be set out in writing, detailing the reasons leading to the change and the modifications required.

Sequence of Events

24 Heath Drive

Sequence of events

It is considered that prior to each event all matters pertaining to the trees should be checked and liaison made with an Arboriculturist, including a site inspection where necessary.

Sequence	Brief outline of events	Arboricultural monitoring requirement
1	Pre-commencement meeting	Site visit
2	Carry out all recommended tree works as listed in the schedule of tree works.	Arboriculturist inspection and completion of site monitoring form on completion of tree works.
3	Install all Protective Barriers and Tree Protection Box as indicated on the Tree Protection Plan	
4	Establishment of all ground protection as indicated on the Tree Protection Plan	
5	Establishment of temporary storage areas as indicated on the Tree Protection Plan	Arboriculturist inspection and completion of site monitoring form to check items 2, 3 and 4
6	Demolition works as proposed	
7	Commencement to completion of construction of build works	
8	Removal of protective barriers, ground protection and temporary storage area to the front of the property	
9	Installation of trenching for Air Conditioning Units, lighting and kerb edging to front of property	Arboriculturist supervision and report
10	Installation of drive way	Arboriculturist supervision and report
11	Removal of protective barrier to rear of property	
12	Landscaping works to rear of property including excavations, fencing and turfing.	Arboriculturist supervision and report
13	Removal of temporary storage area	
14	Re-inspection of retained trees	Arboriculturist report and site monitoring form

Appendix 1: Protective Barriers and Protective Tree Box

24 Heath Drive

Figure 1a and 1b: Diagram of default (left) and alternative (right) protective barriers taken from BS 5837 (2012)

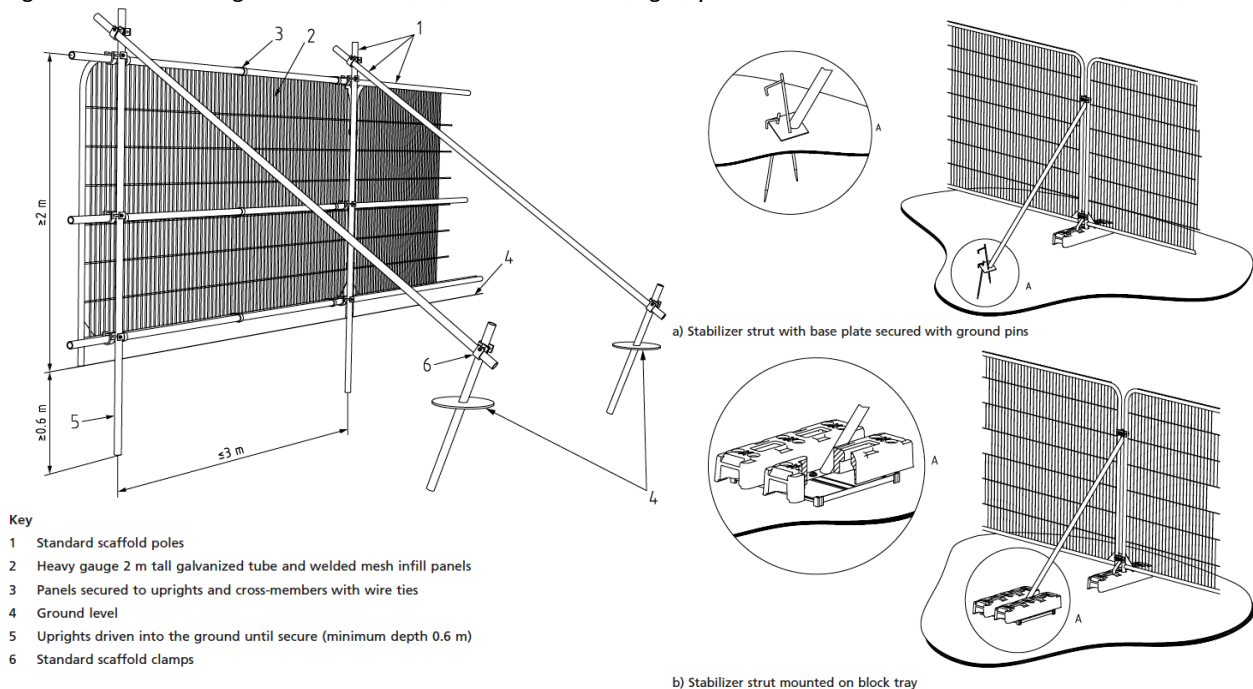

Before the commencement of any works on site (other than those set out in the schedule of tree works, contained in this document), protective vertical barriers must be erected. The location of the barriers is illustrated on the Tree Protection Plan. However, it must be noted that these locations are indicative at present, construction methodologies may evolve such that the barrier locations may require amendment or supplementing. The barriers are to be erected to exclude construction activity in the RPAs of retained trees. The barriers will remain in place until completion of the main construction phase and then only removed with the agreement with the consulting Arboriculturist. Other than works detailed within this method statement or approved in writing by the local planning authority, no works shall take place within the exclusion zones defined by the protective fencing. No vehicles will be allowed to enter areas to be protected by fencing.

Specification of Protective Barriers

The barriers should be fit for purpose of excluding construction activity. At this site, it is considered sufficient to install two-metre-tall welded mesh or solid panels on concrete feet (please refer to figures 1a and 1b). The fence panels (Heras type) should be joined together using a minimum of two anti-tamper couplers and installed so they can only be removed from the inside. The distance between the fence couplers should be at least 1 metre and should be uniform throughout the protective barrier. The panels should be supported on the inner side by angled stabilizer struts installed every 3.5 metres at the join of the fence panels. Both the concrete feet and the stabiliser strut base plates should be secured with ground pins. Where fencing is to be erected on retained hard surfaces or it is otherwise unfeasible to use ground pins stabilizer struts should be mounted on a block tree. The specification of the temporary barriers will be installed in accordance with the specification as discussed in the paragraph above and referenced in figures 1a and 1b. Notices will be affixed to all protective fencing 'Construction exclusion zone - Keep Out' (please refer to figure 2).

Appendix 1: Protective Barriers and Protective Tree Box 24 Heath Drive

Protective Tree Box

The retained tree T1 London Plane is located in the comparatively narrow footway and thus the installation of conventional protective barriers is not considered viable. It is therefore necessary to construct a tree protection box/ hoarding around this tree to protect during construction. The following methodology should be adopted.

1. A wooden four-sided tree protection box/ hoarding must be constructed around the main stem of T1 London Plane.
2. The box formed around the stem should be of stout construction to prevent direct damage. Plywood at least 18mm thick is suggested.
3. The timber box is to be attached to a free-standing internal scaffold pole frame.
4. No part of the internal frame is to come into contact with the tree stem.
5. The box must be constructed to a height of at least 2.0 metres above ground level.
6. The scaffold frame and base of the wooden box must be located, so that it does not rest on or against any exposed roots or root buttresses.
7. The scaffold pole frame is to be supported by high visibility; high density concrete stabilization blocks aligned parallel to the road to avoid them encroaching the pavement.
8. Any painting or preparation of the tree boxes must be carried out in advance prior to installation and not once the structure is in place.
9. The dimensions and location should be adhered to as shown on the Tree Protection Plan.

Appendix 1: Specification and Design of Protective Barriers 24 Heath Drive

Figure 2 - Photo of Heras panels affixed to scaffold and



Figure 3 – Example of suitable warning sign affixed to protective barrier



Appendix 2: Installation of Ground Protection 24 Heath Drive

Ground Protection will be installed in areas as indicated on the TPP according to the level of use, as follows.

A. Pedestrian movement and pedestrian-operated machinery up to a gross weight of 2 tonnes

Lay an impermeable geo-textile matting directly onto the soft ground, onto which will be installed a layer 150 millimetres thick of a compressible material such as woodchip, capped with a finished surface of interlinked ply-board sheets or proprietary ground protection boards.

B. Machinery in excess of 2 tonnes gross weight

The area shall be protected by the laying of an impermeable membrane onto the site surface. Any levelling off of the ground surface prior to laying the impervious membrane surface shall be made using soil or aggregate infill of hollows to build up to a general site level, no excavation or grading of surfaces will be allowed. Onto this base shall be laid a geotextile pocketed mat, in-filled with inert coarse aggregate to a depth of 150 millimetres spread and levelled to form a wearing surface. Onto which proprietary interlinking ground protection boards can then be installed.

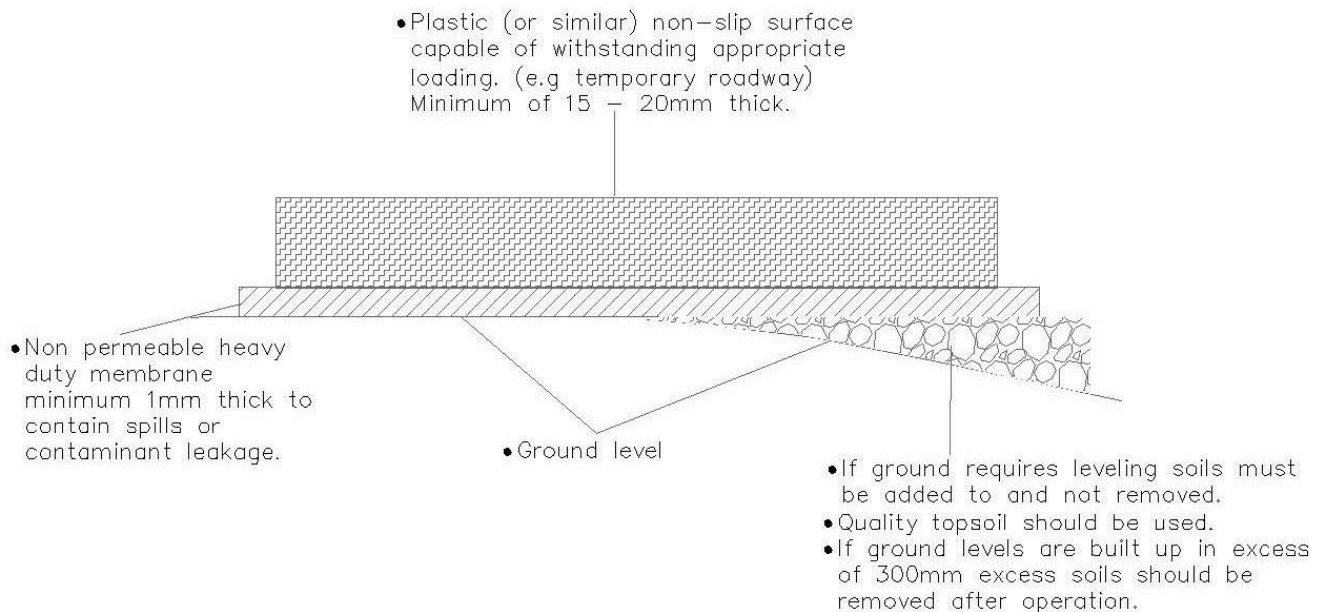

Based on the anticipated comparatively low level of access for heavy machinery proprietary interlinking ground protection boards such as 'Ground Guard' and 'TuffTrack' would be adequate in this case.

Appendix 2: Installation of Ground Protection 24 Heath Drive

Rubber ground protection mats

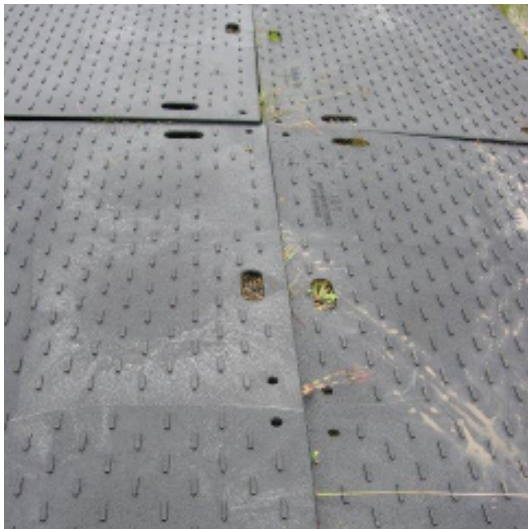

Aluminium temporary road way



Appendix 3: Example Site Monitoring Form 24 Heath Drive

Site Monitoring Form	
Arboricultural Consultant's Details	
Consultant's Name:	
Tel:	
Mobile:	
Development Site Details	
Address:	
Planning Application Ref:	
Local Authority Details (LPA):	
LPA:	
LPA Tree Officer:	
LPA Case Officer/ Contact:	
Developer's Details	
Developer name:	
Address:	
Contractor Details:	
Contractor name:	
Contact name:	
Date:	
Stage of Development:	
Purpose of visit	
Protective Barriers	
Ground Protection	
Compaction	
Damage to retained trees	
Other notes	
Photos	
Further action required:	
Date of next site visit:	
Date this form sent to Local Planning Authority	

Appendix 4: Limitations 24 Heath Drive

Limitations of the Report

The report is based on information provided by third parties and the specifications and recommendations is dependent upon information provided therein.

This report does not consider the possible implications to any present or future built structures other than those considered within the report.

Findings of the Survey and the Report

Validity, accuracy and findings of the report will directly relate to the accuracy of information provided at the time of the tree survey.

Timing of the Survey and the Report

The considerations/ findings in this method statement are valid for one year.

Such considerations/ findings will become invalid if any building works are undertaken, soil levels are altered or tree work undertaken outside of the scope of works as detailed and presented at the time of compiling this report.

If there are any alterations to either the property or soil levels, or if tree works are carried out, it is recommended that a new tree report is undertaken.

Trees in relation to other Properties

This report/survey only considers the trees in relation to the site as identified. It does not comment on possible effects of trees on neighbouring properties, including in relation to subsidence or heave, or with regard to possible hazards presented by trees surveyed.

Neighbouring owners of trees that are identified as posing a possible risk to the property/site in question should seek their own advice as to possible effects of the recommendations given within this report.

Damage to, or possibility of damage to, any other structure that is not referred to within the report is not considered unless otherwise specified. This includes both neighbouring structures and any other structure on the property.

Trees in Relation to Subsidence, Heave and Direct damage

This report does not deal with issues relating to subsidence or heave in relation to any built structures and surrounding vegetation whether the structure or vegetation falls within the boundaries as considered or lies beyond the boundaries.

The report does not consider issues relating to subsidence or heave in relation to any proposed built structures or future vegetation whether within the boundaries as considered or beyond the boundaries

It is prudent to consider the effects of heave on any property if trees are removed. Similarly, the issue of direct damage (when the roots of a tree have physical contact with a structure) is not considered within this report.

Appendix 4: Limitations 24 Heath Drive

Trees subject to statutory controls:

If the trees are covered by a Tree Preservation Order or are located in a conservation area it will be necessary to consult the local authority before any pruning works, other than certain exemptions, can be carried out.

The works specified above are necessary for reasonable management and should be acceptable to the local authority. However, tree owners should appreciate that the local authority may take an alternative point of view and have the option to refuse consent.

Trees are subject to changes outside man's control

Trees are living organisms subject to changes outside man's control. Trees and environment alter with the seasons it is as well to inspect trees whilst in full leaf and when out of leaf.

If there are any harsh or unexpected weather conditions, or heavy storms it is also prudent to inspect trees.

Changes to ground water conditions will affect the root growth of a tree. Such changes are not always the result of man's influence and others factors may be involved.
