

de59 Detail Showing Block E Window Section
1:5 @ A1, 1:10 @ A3

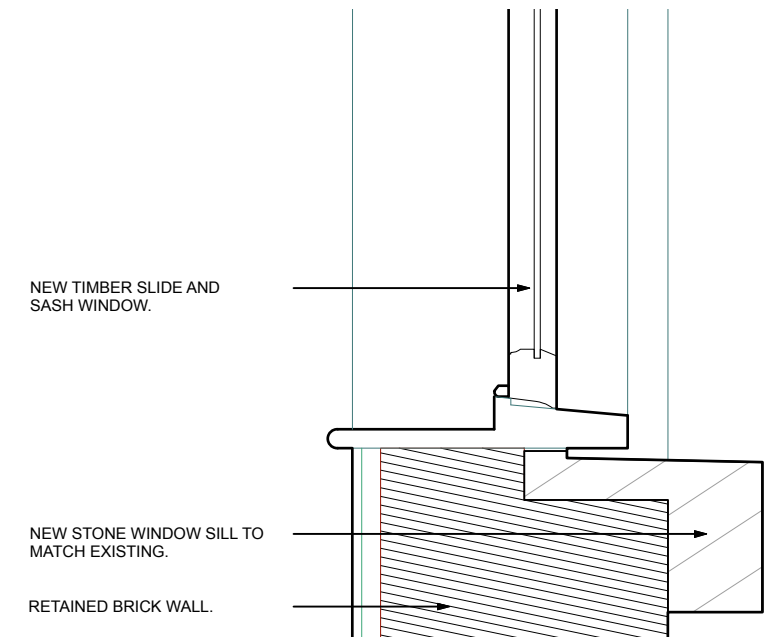

de60 Detail Showing Block E Window Section
1:5 @ A1, 1:10 @ A3

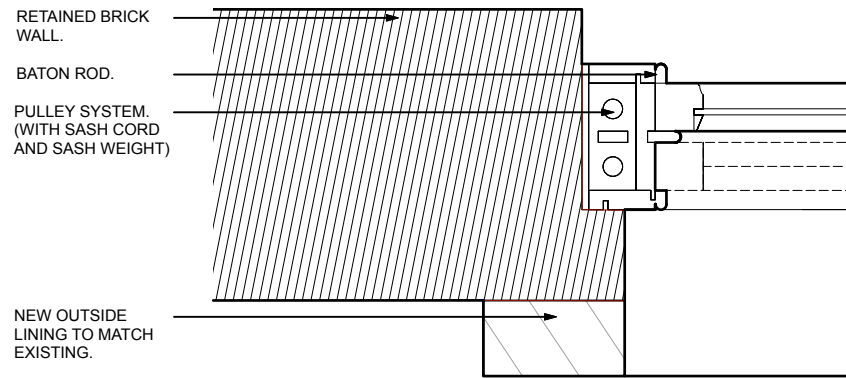

de62 Detail Showing Block E Window Plan
1:5 @ A1, 1:10 @ A3

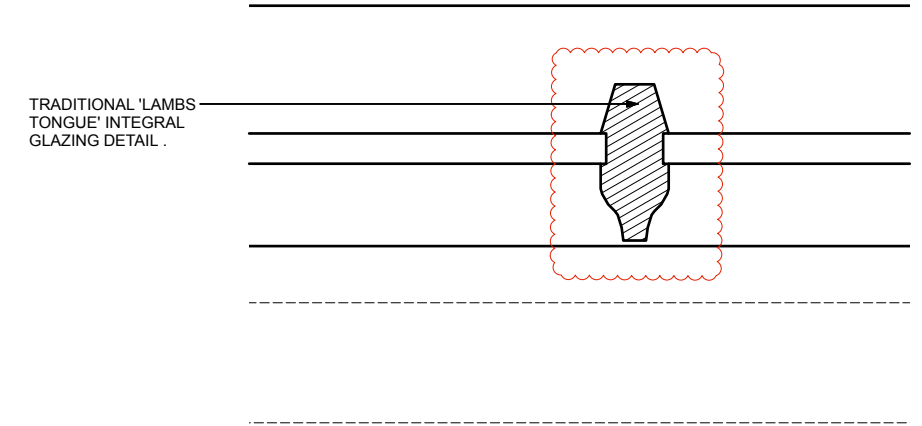

de61 Detail Showing Block E Window Lambs Tongue
1:1 @ A1, 1:2 @ A3

de58 Detail Showing Block E Window Elevation
1:10 @ A1, 1:20 @ A3

Setting out and all G.A. drawings prepared from survey information provided by others.
All setting out must be checked on site.
All levels must be checked on site and refer to Ordnance Datum Newlyn unless alternative Datum given.
All fixings and weatherings must be checked on site.
All dimensions must be checked on site.
This drawing must be read in conjunction with the relevant specification clauses.
This drawing must not be used for land transfer purposes.
This drawing must not be used on site unless issued for construction.

WARNING TO HOME BUYERS
Property Misdescriptions Act 1991
Buyers are warned that this is a working drawing and not intended to be treated as descriptive material describing in relation to any particular property or development, any of the specified matters prescribed by any order and under the above act. The contents of this drawing may be subject to change at any time and alterations and variations can occur, during the progress of the works without revision of the drawing. Consequently the layout, form, content and dimensions of the finished construction may differ materially from those shown. Nor do the contents of this drawing constitute a contract, part of any contract or warranty.

THIS IS A DESIGN INTENT DRAWING. SUB-CONTRACTOR / SUPPLIERS DETAILED DRAWINGS AND SPECIFICATIONS TO BE SUBMITTED FOR DESIGN TEAM INFORMATION AND/OR COMMENT

Notes

NEW BUILD RESIDENTIAL AND COMMERCIAL CONSTRUCTION TO ACHIEVE THE FOLLOWING MINIMUM U-VALUES (w/m²k)

ROOFS	0.2
WALLS	0.15
FLOORS	0.2
WINDOWS	1.4
DOORS	1.4
AIR PERMEABILITY	5

REFURBISHMENT RESIDENTIAL CONSTRUCTION TO ACHIEVE THE FOLLOWING MINIMUM U-VALUES (w/m²k)

ROOFS	0.2
WALLS	0.5
FLOORS	0.25
WINDOWS	2.0
DOORS	2.0
AIR PERMEABILITY	10

REFURBISHMENT COMMERCIAL CONSTRUCTION TO ACHIEVE THE FOLLOWING MINIMUM U-VALUES (w/m²k)

ROOFS	0.2
WALLS	0.5
FLOORS	0.25
WINDOWS	2.0
DOORS	2.0
AIR PERMEABILITY	10

* Floor finishes in front of the lifts to be "feathered-up" to give FFL+25mm at the lift entrance thresholds.

REFURBISHMENT RESIDENTIAL CONSTRUCTION TO ACHIEVE THE FOLLOWING MINIMUM U-VALUES (w/m²k)

ROOFS	0.2
WALLS	2.1 Unmodified
FLOORS	0.25
WINDOWS	2.0
DOORS	2.0
AIR PERMEABILITY	10

* Issued For Condition Discharge 02/11/17
A Issued For Condition Discharge 26/04/19

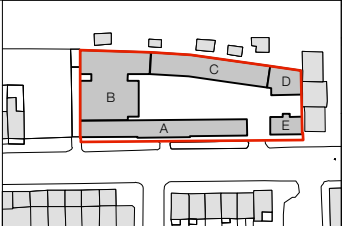

Client
St Ermins Property Company Limited
314 Goswell Road,
London,
EC1V 7AF
Tel: +44(0)20 7952 0252
www.21starchitecture.com

Project
44 Gloucester Avenue
London NW1 8JD

Drawing Title
Proposed Envelope Drawings - Window Detail

Status
Construction

Scale
1:5 @ A1, 1:10 @ A3

Drawn
CM

Checked
TJS

Date
April 2019

Drwg. No.
173_E_PL-COND_04_01 A

Revision

Twenty First Architecture Ltd,
314 Goswell Road,
London,
EC1V 7AF
Tel: +44(0)20 7952 0252
www.21starchitecture.com