

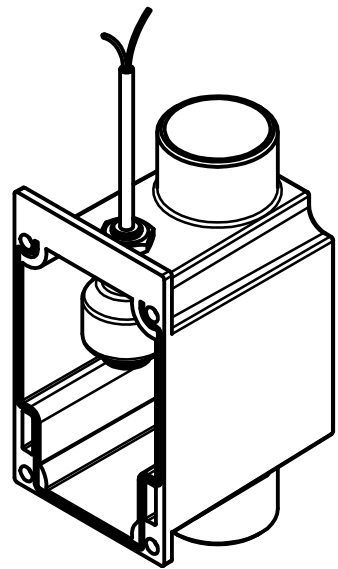

4x

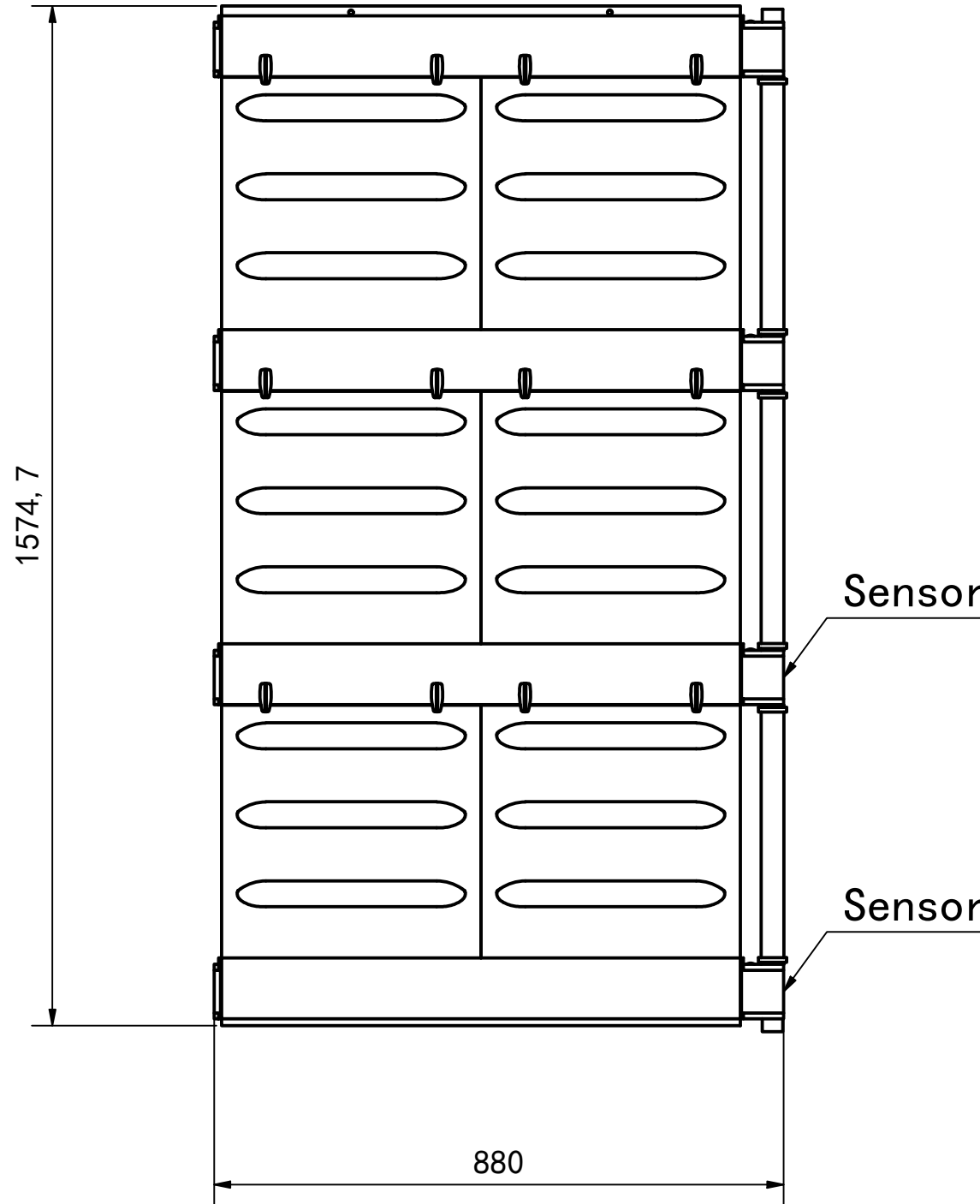

Sensor : 2x

$$0,880 \times 1,5747 = 1,39 \text{ m}^2$$

	DATE	19-2-2019	DRAWING NO.		
	DRAWN	qdp/QDP	19-2287-01-03		
	UNITS	mm			
		REV	A	C	
			B	D	
		PROJECT NAME			Format
		Rokit, London (3)			A3
SIGN FOR APPROVAL		SIGN DATE			

6

5

4

3

2

1

4x

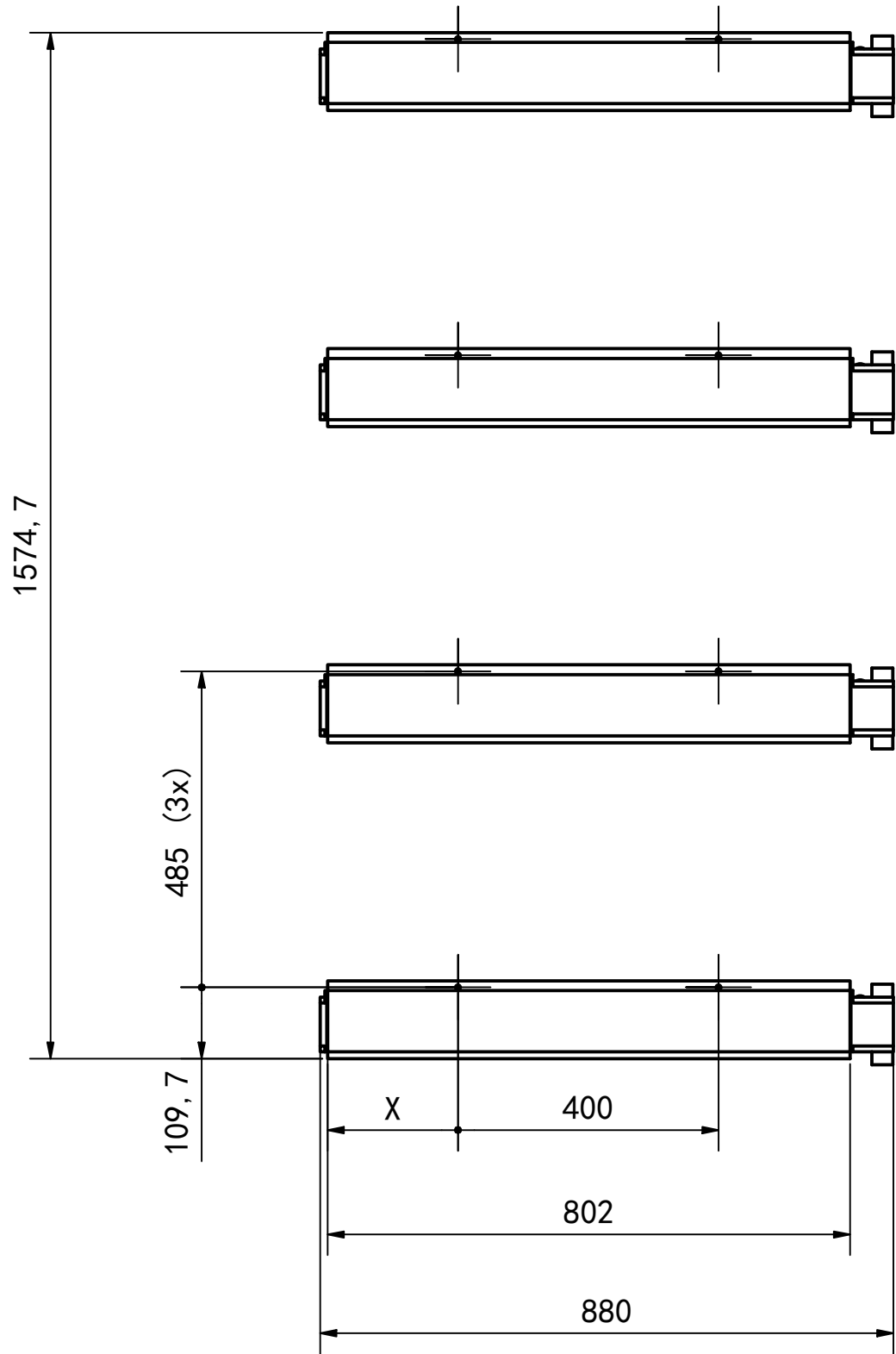

$0,880 \times 1,5747 = 1,39 \text{ m}^2$

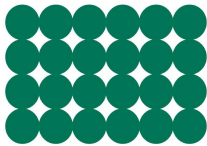
	DATE	19-2-2019	DRAWING NO.		
	DRAWN	qdp/QDP	19-2287-01-03		
	UNITS	mm			
		REV	A	C	
			B	D	
		PROJECT NAME			Format
		Rokit, London (3)			A3
SIGN FOR APPROVAL	SIGN DATE				

4x

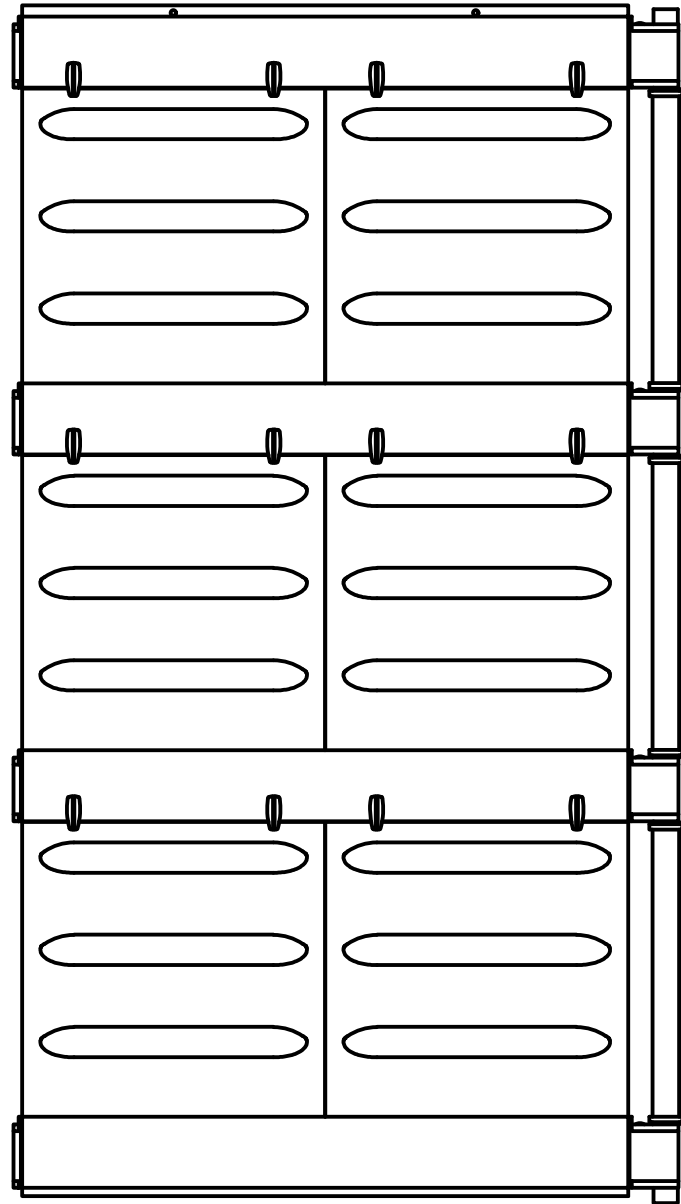

Part List

Part Name	QTY	Description
14-0122-00-01_L802	4	Profile (L=802)
14-0122-00-09	12	Cassette clip
14-0122-00-12	4	Endcap 2K
14-0122-00-13	4	Hose connection 2K
14-0122-99-00	1	Spare part kit
14-0122-99-01_3	3	Tube
14-0122-99-02	6	Hose clamp
14-0122-99-04	4	Plug
14-0122-99-05	32	DIN-7981/A2 3,9x19 T15 + Gleitmo 625
14-0122-99-06	8	fischer UX 8x50
14-0122-99-07	8	fischer 5.0 x 60 CK RVS A2
18-1678-01-00_3SL	6	Cassette (slots)
14-0122-99-03	2	Sensor

1,39 m2

	DATE	19-2-2019	DRAWING NO.	
	DRAWN	qdp/QDP	19-2287-01-03	
	UNITS	mm		
SIGN FOR APPROVAL	SIGN DATE	REV	A	C
			B	D
PROJECT NAME			Format	
Rokit, London (3)			A3	

All rights are reserved. Reproduction in whole or in part is prohibited without the written consent of the copyright owner. 版权所有，未经许可不得制造生产图纸。