

Proposed Glazed Partition Abutment Details

Wall Abutment

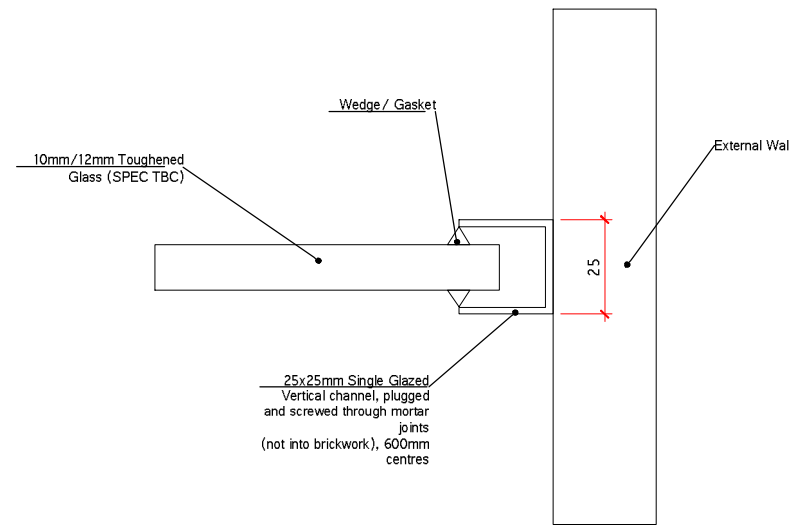

Floor Detail

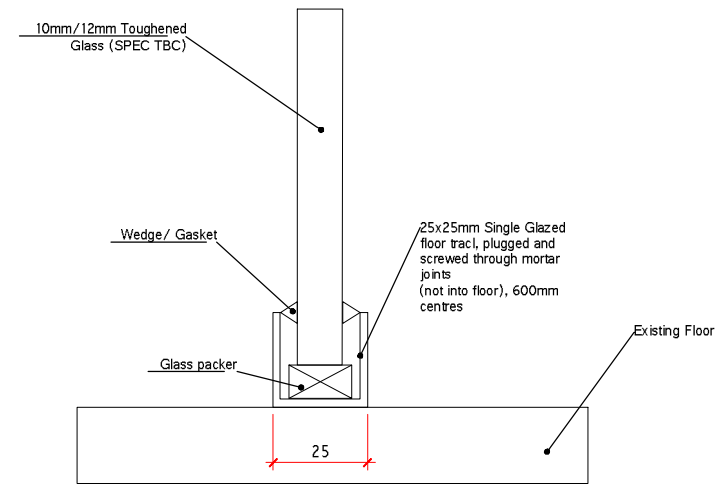

Proposed Wall/Floor Abutment Details

Wall Abutment

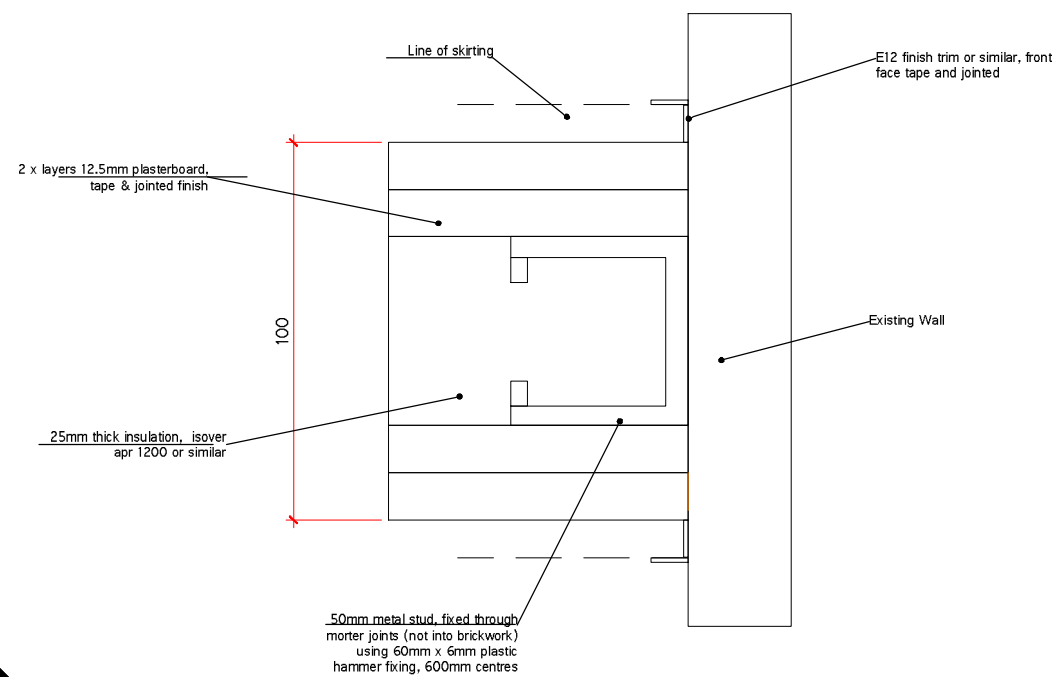

Floor Detail

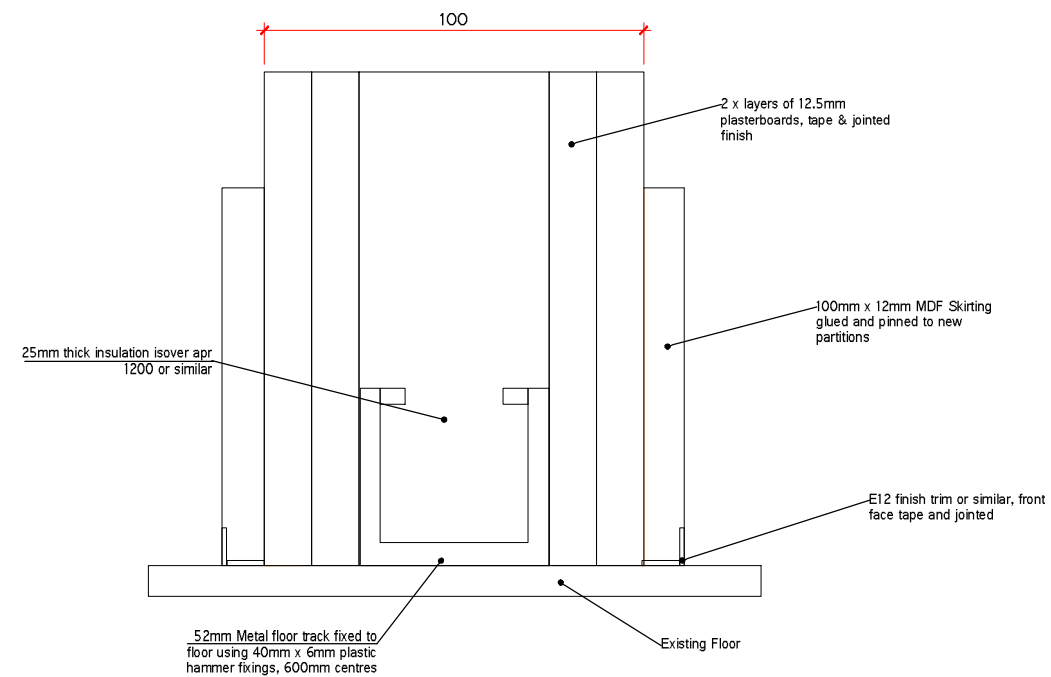

NOTES

THIRDWAY INTERIORS DO NOT ACCEPT LIABILITY FOR ANY ERRORS AND OMISSIONS ARISING FROM THE PREPARATION OF BASE BUILD DRAWINGS WHICH ARE DERIVED FROM ORIGINAL MATERIAL PROVIDED BY OTHERS.
 ALL DISCREPANCIES ARE TO BE REPORTED TO THIRDWAY INTERIORS.
 GRID LINES ARE FOR REFERENCE PURPOSES ONLY.
 ALL DIMENSIONS TO BE VERIFIED BY CONTRACTOR ON SITE PRIOR TO ANY WORKS COMMENCING.
 DO NOT SCALE FROM THIS DRAWING.
 THIS DOCUMENT IS THE PROPERTY OF THIRDWAY INTERIORS.
 COPYRIGHT IS RESERVED BY THEM, AND THE DRAWING IS ISSUED ON THE CONDITION THAT IT IS NOT COPIED, REPRODUCED OR RETAINED BY, NOR DISCLOSED TO ANY UNAUTHORISED PERSON, EITHER WHOLLY OR IN PART, WITHOUT THE CONSENT IN WRITING FROM THIRDWAY INTERIORS.

©THIRDWAY INTERIORS

STATUS

- Concept / Information
- Building Control
- Approval / Comment
- Contract
- Construction
- As-Built

REVISION DETAIL

| REV | DETAIL | BY | DATE |
|-----|--------|----|------|
| - | - | - | DDMM |
| - | - | - | - |
| - | - | - | - |
| - | - | - | - |
| - | - | - | - |
| - | - | - | - |
| - | - | - | - |

CLIENT

COINCRAFT

PROJECT ADDRESS

**26 PARKER ST
LONDON
WC2B 5PH**

DRAWING TITLE

**26 PARKER ST
PROPOSED TYPICAL
WALL FINISH DETAILS**

DWG NO: **18834-00-WALL**

REVISION: **A**

SCALE @A1: **1:1** @A3: **1:2**

DATE: **19.03.19**

DRAWN BY: **ECW**

CHECKED BY: **ECW**



THIRDWAY