

TOP OF ELEVATION;
VENTILATION LOUVRES, EWS05

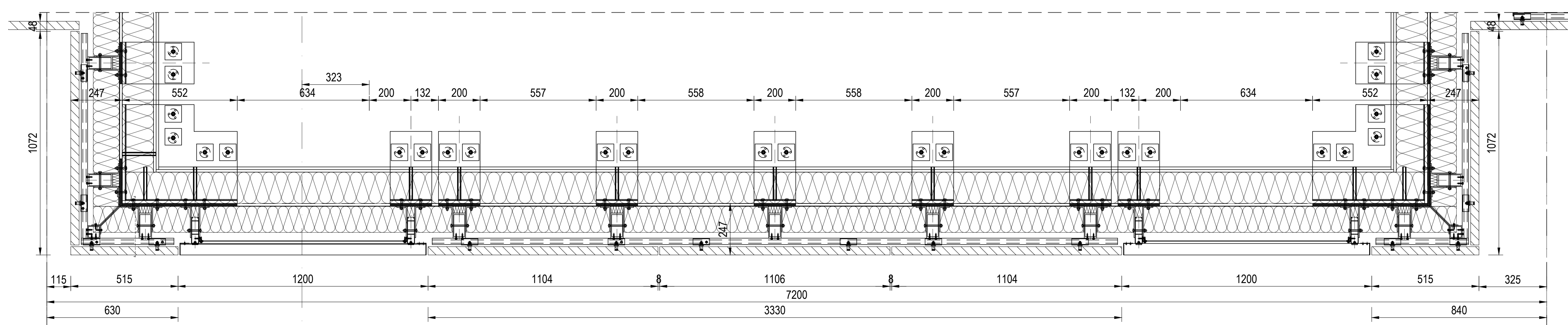
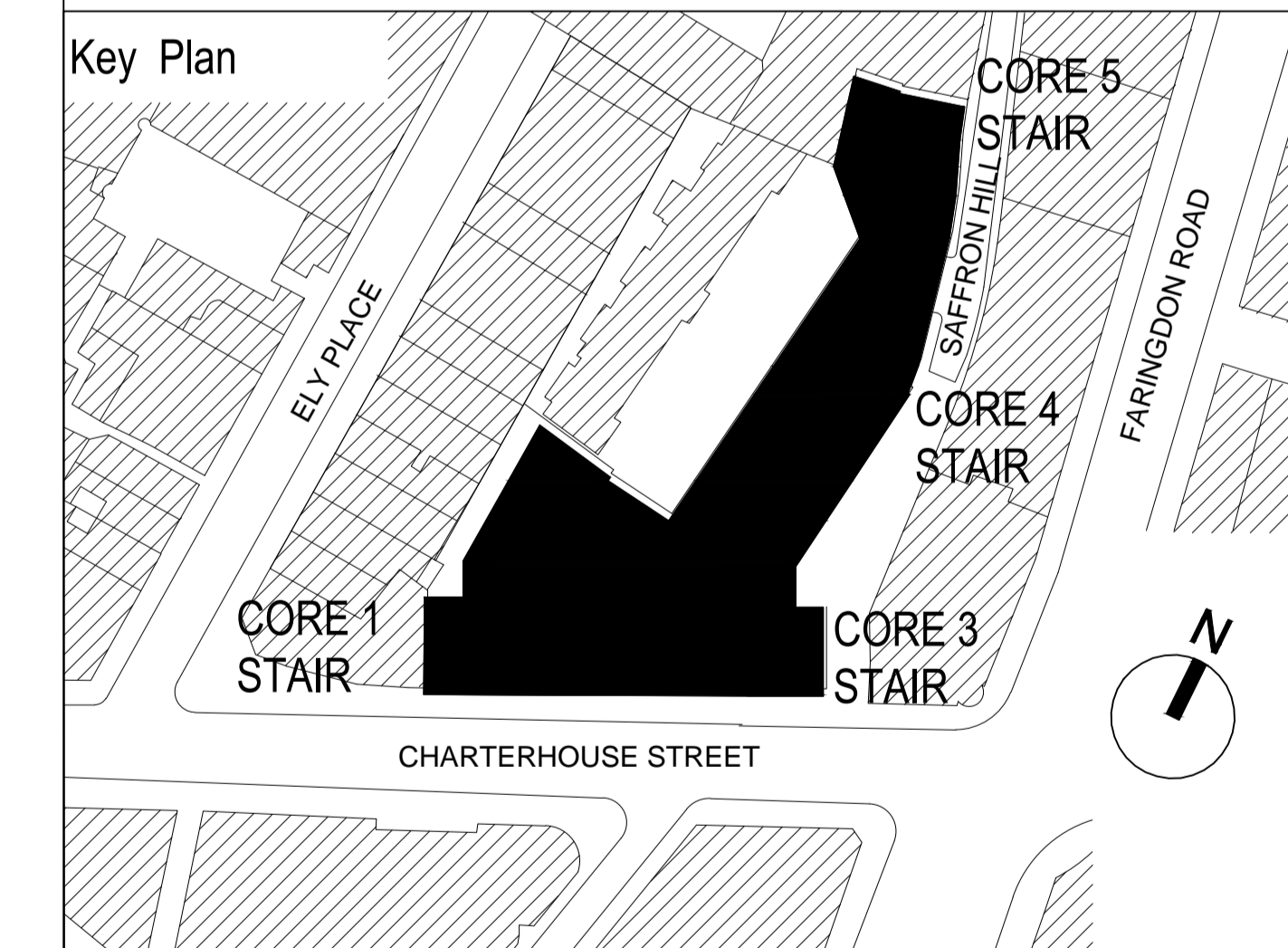
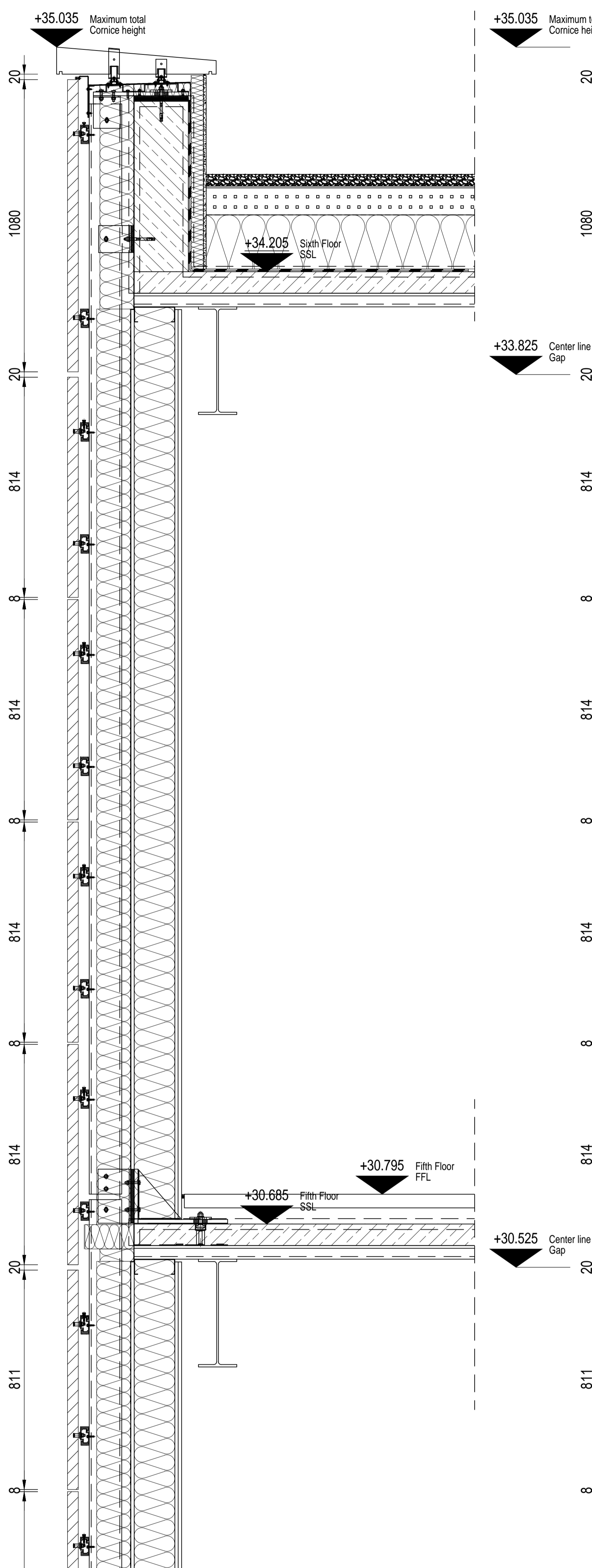
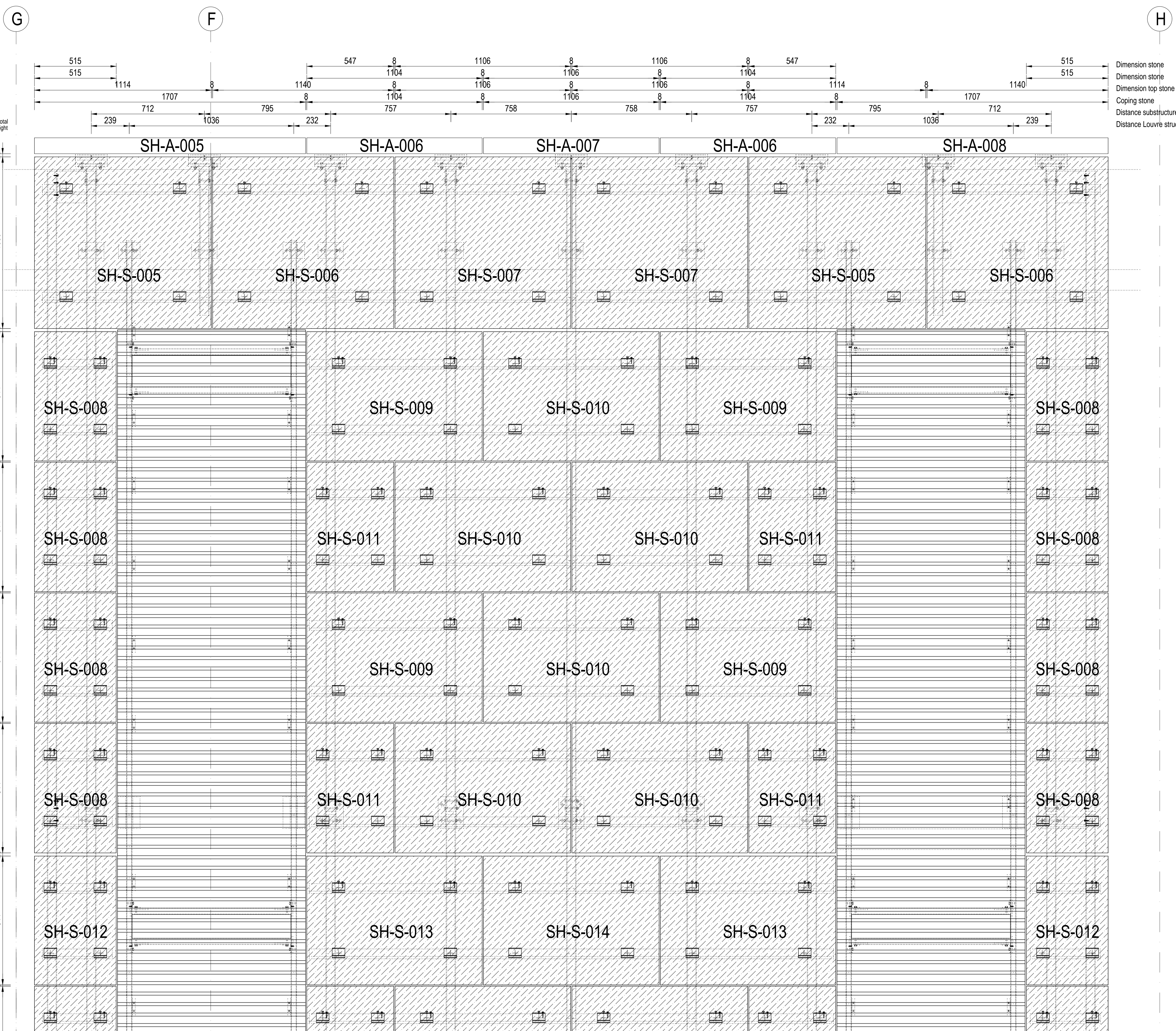

APPROVAL
DATE:

Rev	Revisions	Date	Drawn	Checked
C7				
C6				
C5				
C4				
C3				
C2				
C1				

Schneider GB Ltd
Downstream Offices
Bullers Wharf West
38 Shad Thames
London, SE1 2YD
t +44 (0) 20 7401 6383
www.schneider-facades.co.uk

WINDOWS
FACADES
CURTAIN WALLING

JOB NO.: K30152
CONTRACT: 17 Charterhouse Street
ARCHITECTS: MCM Architecture Limited
DRAWING TITLE: Main Work
EWS-05
Elevation

Scale: A3, 1:30
A0, 1:10
Date: 19-NOV-18
Checked-by: F.Schurig
Drawn by: A. Figueroa
Revision: 00

Drawing-Nr.: P2020-SGB-MW-05-E-05-002
Copying and distribution to third parties prohibited. Measurements to be re-checked.

This drawing is our property. Each duplication, utilization or passing on to third persons is forbidden and will be pursued.

2B)

Detailed drawings of all balustrades;

D001

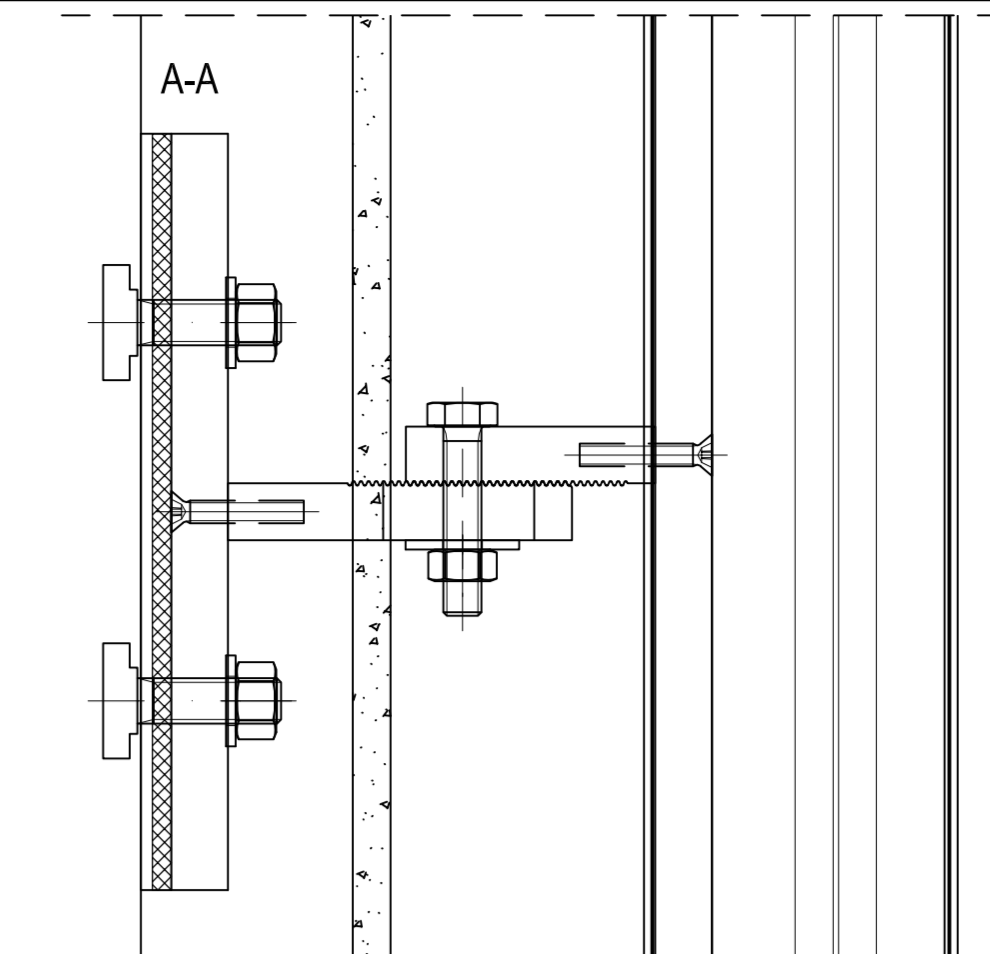

GLASS BALUSTRADE, CLAMPED INTO HORIZONTAL BRACKET, WITH STAINLESS STEEL HANDRAIL. HEIGHT 1100MM ABOVE FFL OF TERRACE.

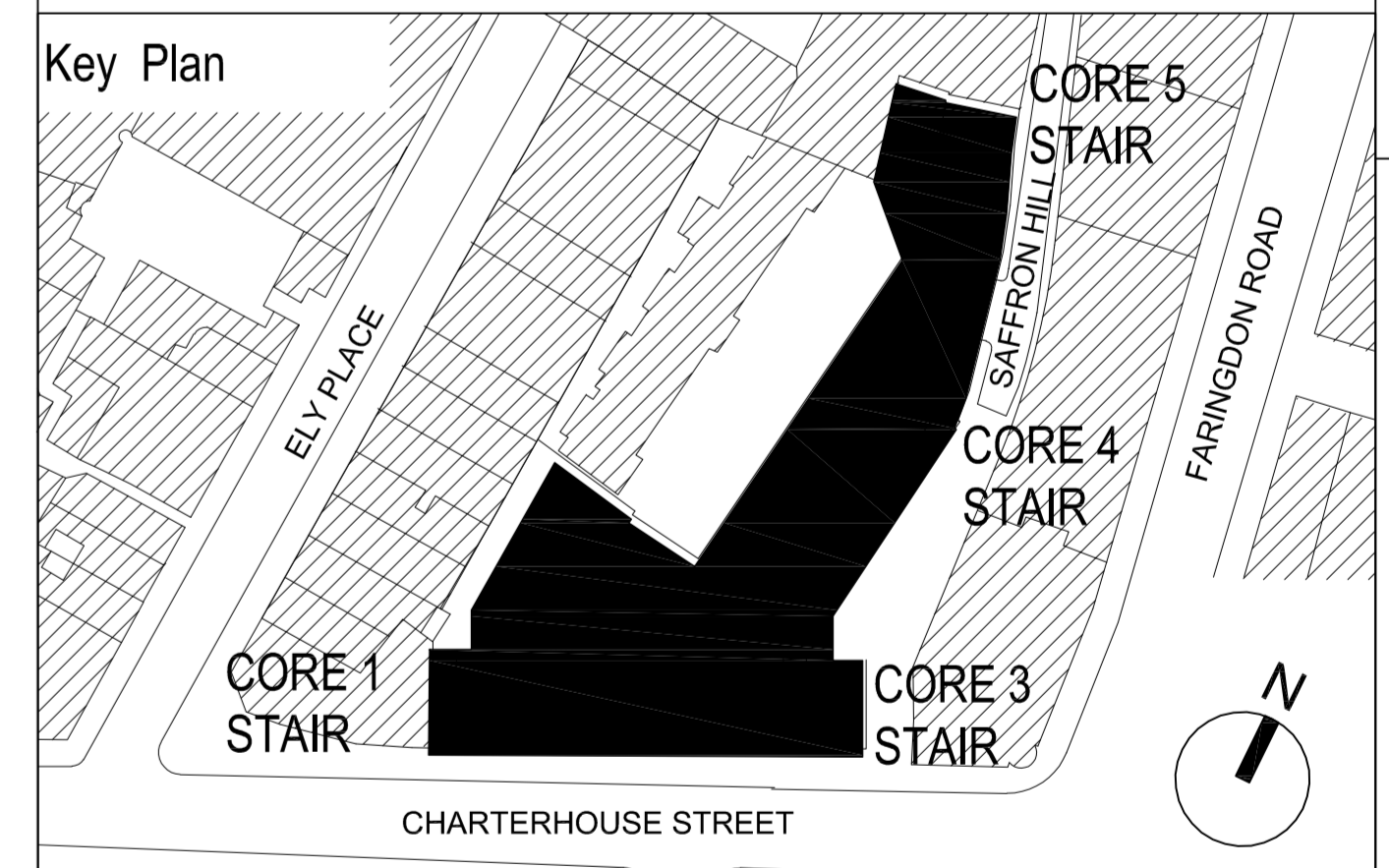
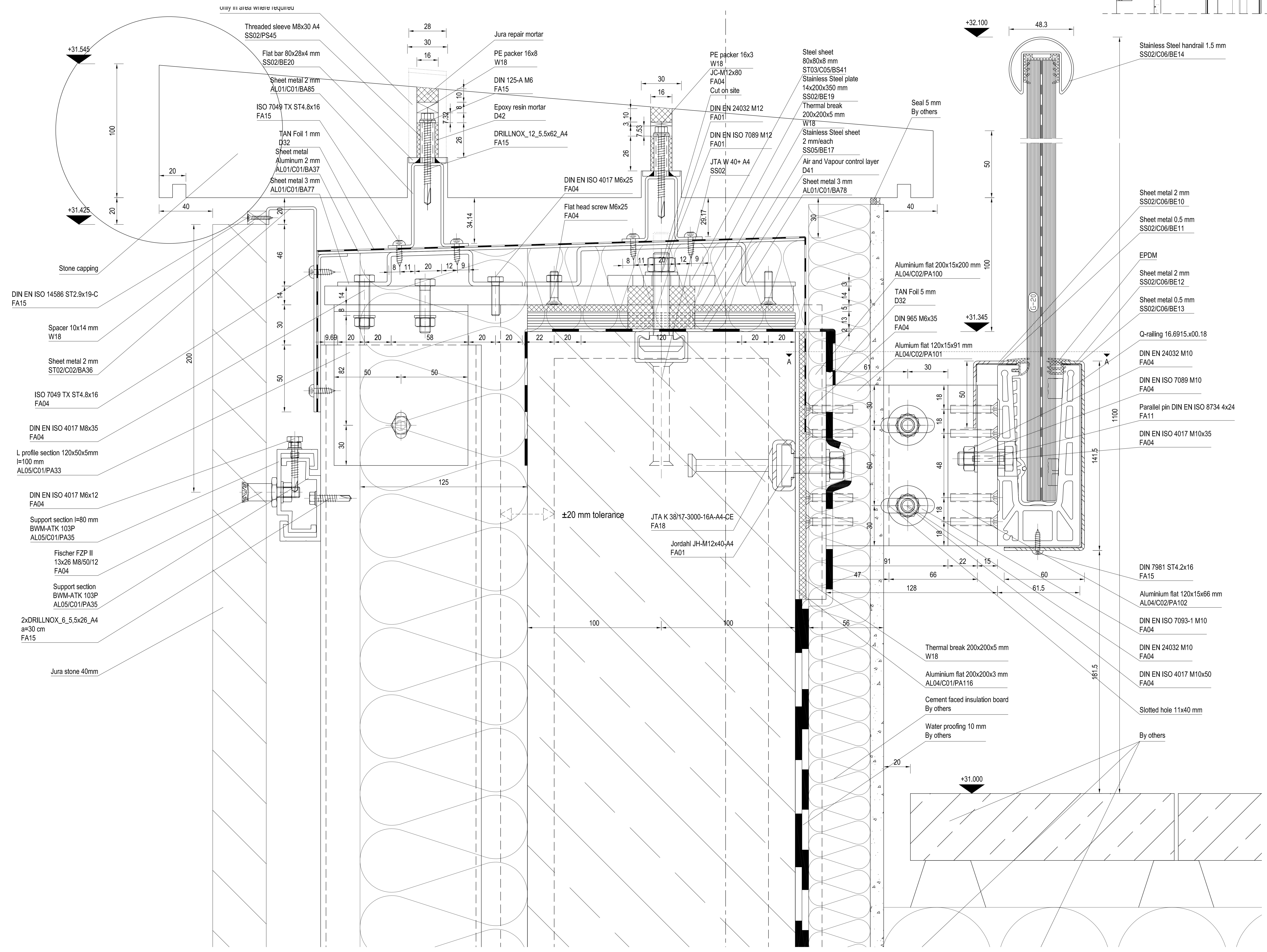

APPROVAL

DATE: _____

Rev	Revisions	Date	Drawn	Checked
C7				
C6				
C5				
C4				
C3				
C2				
C1				

Schneider GB Ltd
Downstream Offices
Bullers Wharf West
38 Shad Thames
London, SE1 2YD
t +44 (0) 20 7401 6383
www.schneider-facades.co.uk

WINDOWS
FACADES
CURTAIN WALLING

JOB NO.: K30152
CONTRACT: 17 Charterhouse Street
ARCHITECTS: MCM Architecture Limited
DRAWING TITLE: Main Work
EWS 06
Vertical section

Scale: A3, L3
A0, L1
Date: 14-DEC-18
Checked-by: F. Schurig
Drawn by: A. Figueroa
Revision: 00

Drawing-Nr.: P2020-SGB-MW-06-0-05-07

This drawing is our property. Each duplication, utilization or passing on to third persons is forbidden and will be pursued.

2C)

Manufacturer's specification details of all facing materials and detailed drawings showing junctions (to be submitted to the Local Planning Authority).

Samples of those materials (to be provided on site)

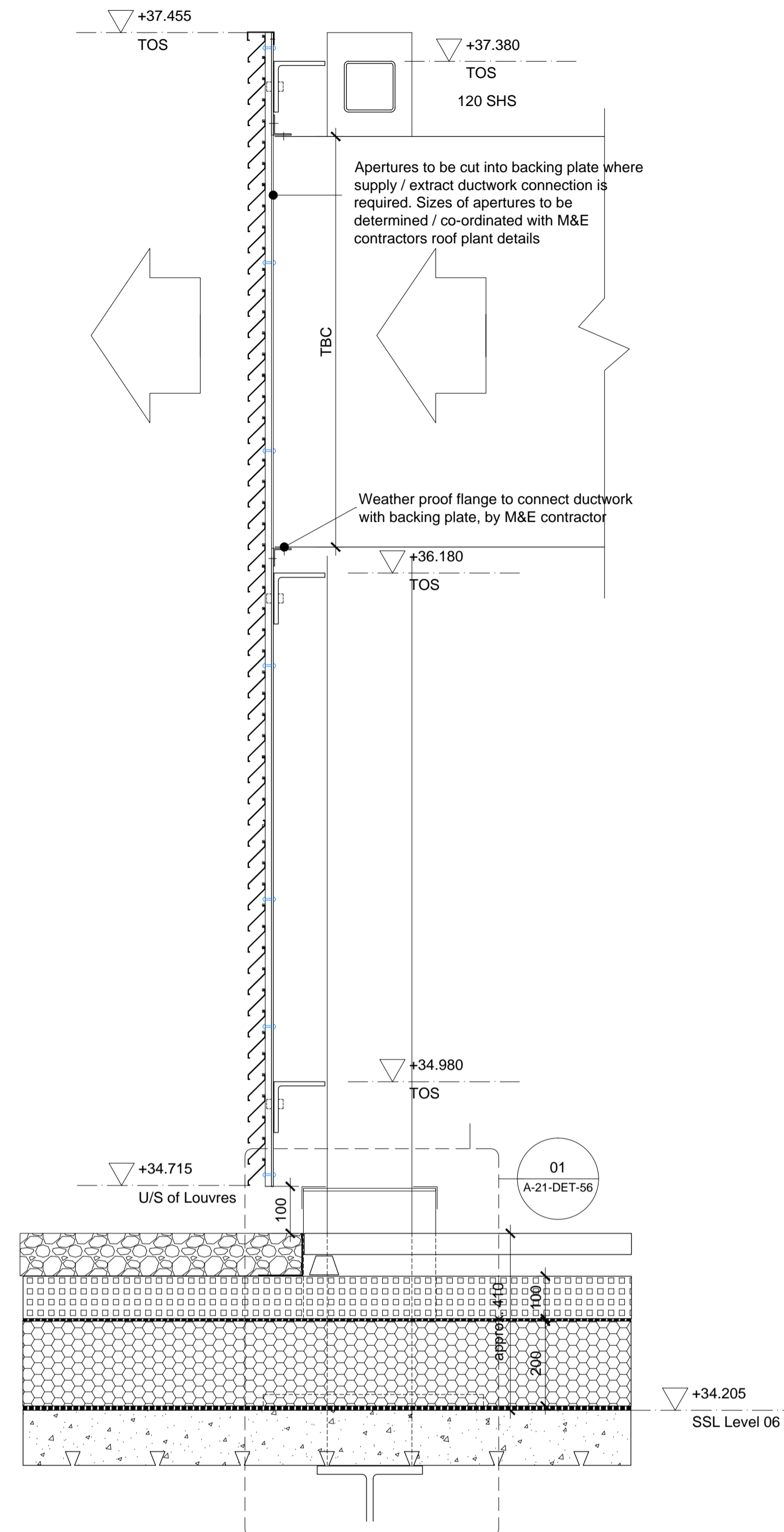
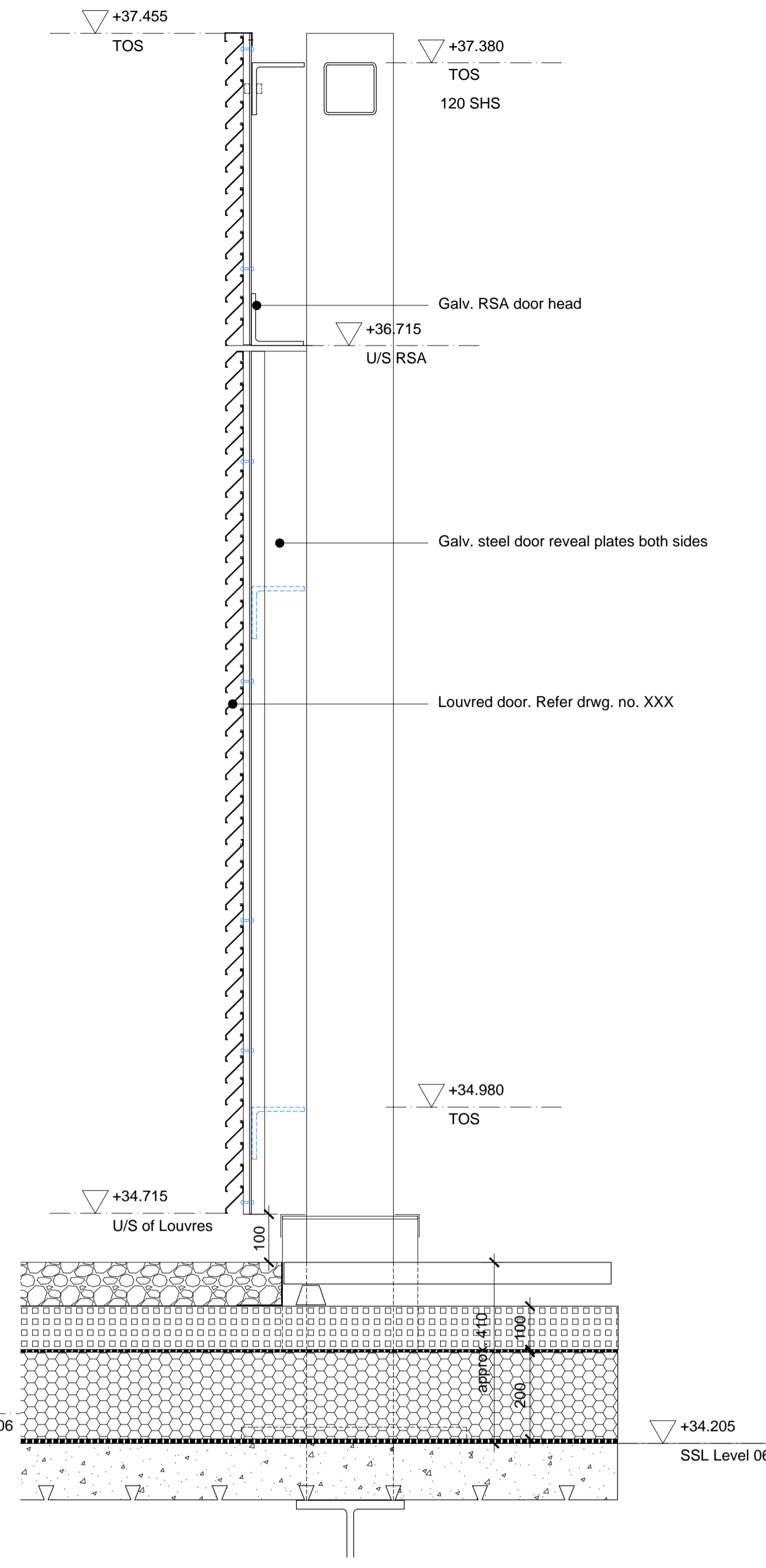
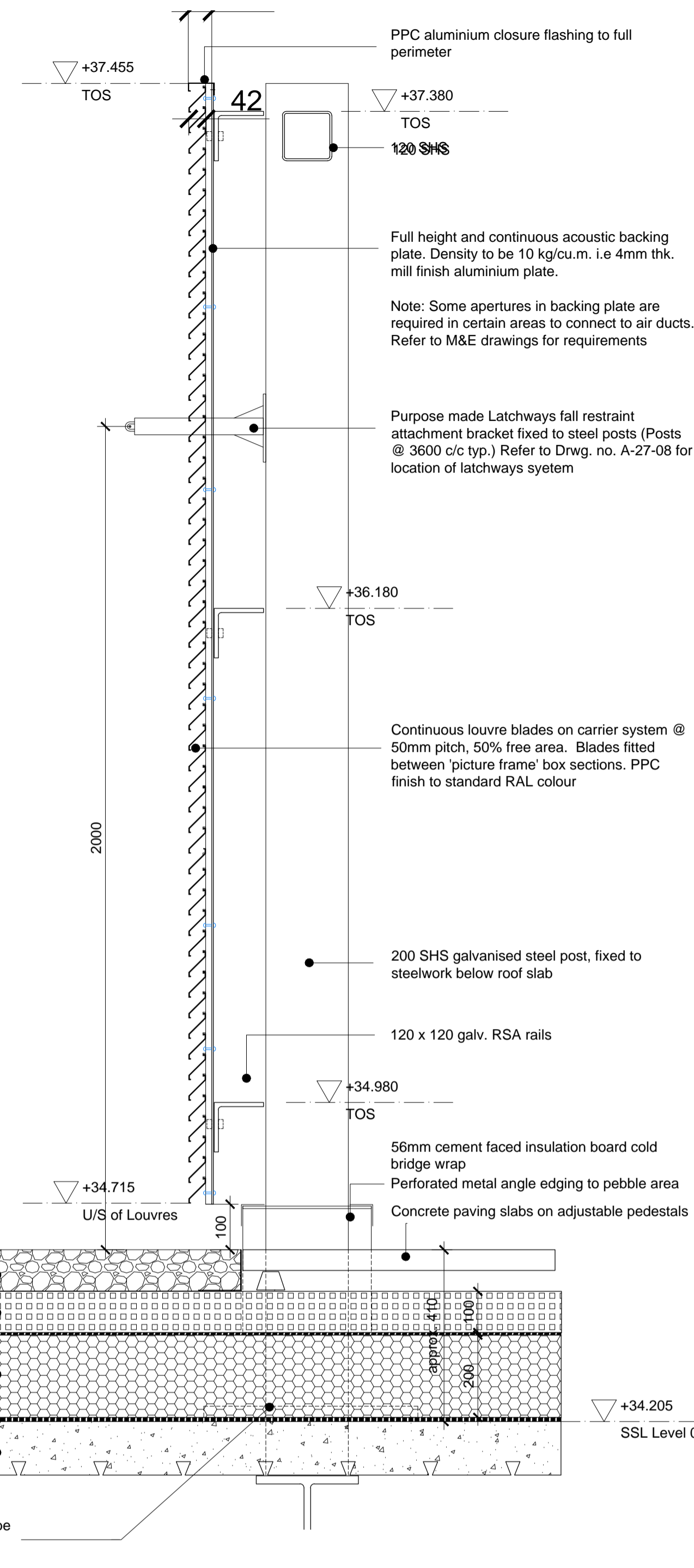

Louvre Blade Systems

Louvres to be Rensen ref. Linius L.050.00 or equal and approved.

Louvre pitch = 50mm

Free Area = 50% or better

Colour: Standard RAL Colour - TBC.
Finish: matt

DETAIL SECTIONS; SAFFRON HILL PLANT SCREEN

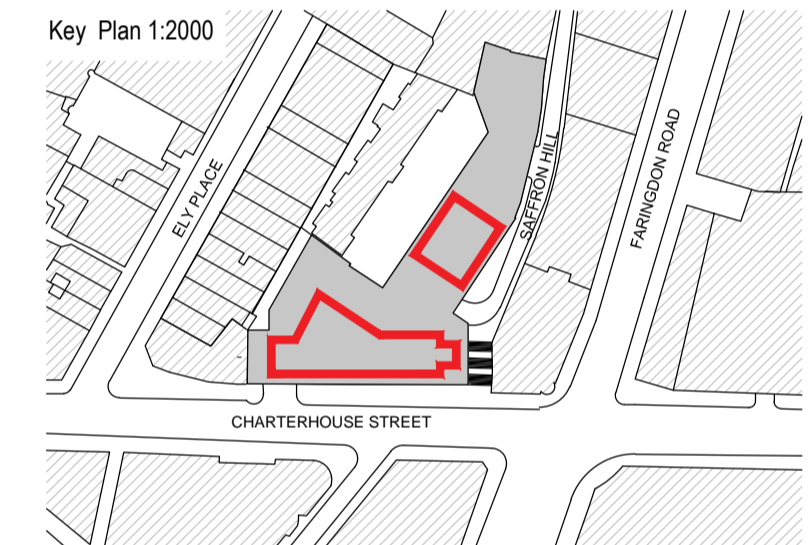
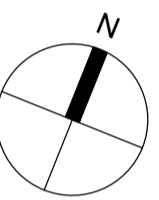

01 Saffron Hill Plant Screen - Typ Section
A-21-DET-54 SCALE: 1:10

02 Saffron Hill Plant Screen - Typ Section at Louvred Door
A-21-DET-54 SCALE: 1:10

03 Saffron Hill Plant Screen - Typ Section Ductwork Connection
A-21-DET-54 SCALE: 1:10

REV	DATE	PURPOSE OF ISSUE	BY
C1	27.02.19	ISSUED FOR CONSTRUCTION	SR
T2	07.08.18	Clarifications as per revision clouds	SR
P1	31.08.18	ISSUED FOR TENDER	SR

CLIENT AA/DB
PROJECT 17 CHARTERHOUSE ST. LONDON
DRAWING ROOF LEVEL LOUVRED SCREEN SAFFRON HILL BUILDING - LVL 6

SCALE A1 @ 1:10, 1:20 STATUS PRELIMINARY
CAD FILE A-21-DET-52 to 56 - Plant Screens.dwg CONSTRUCTION
DRAWN RS AS BUILT
CHECKED SR

DRAWING NO. P17-082 A 21 DET 54 C1
proj. no. ser. floor/type no. rev.

MCM
MCM Architecture Limited T 020 7902 0900 F 020 7922 1233
71 Hopton Street London SE1 9LR www.mcm-uk.com

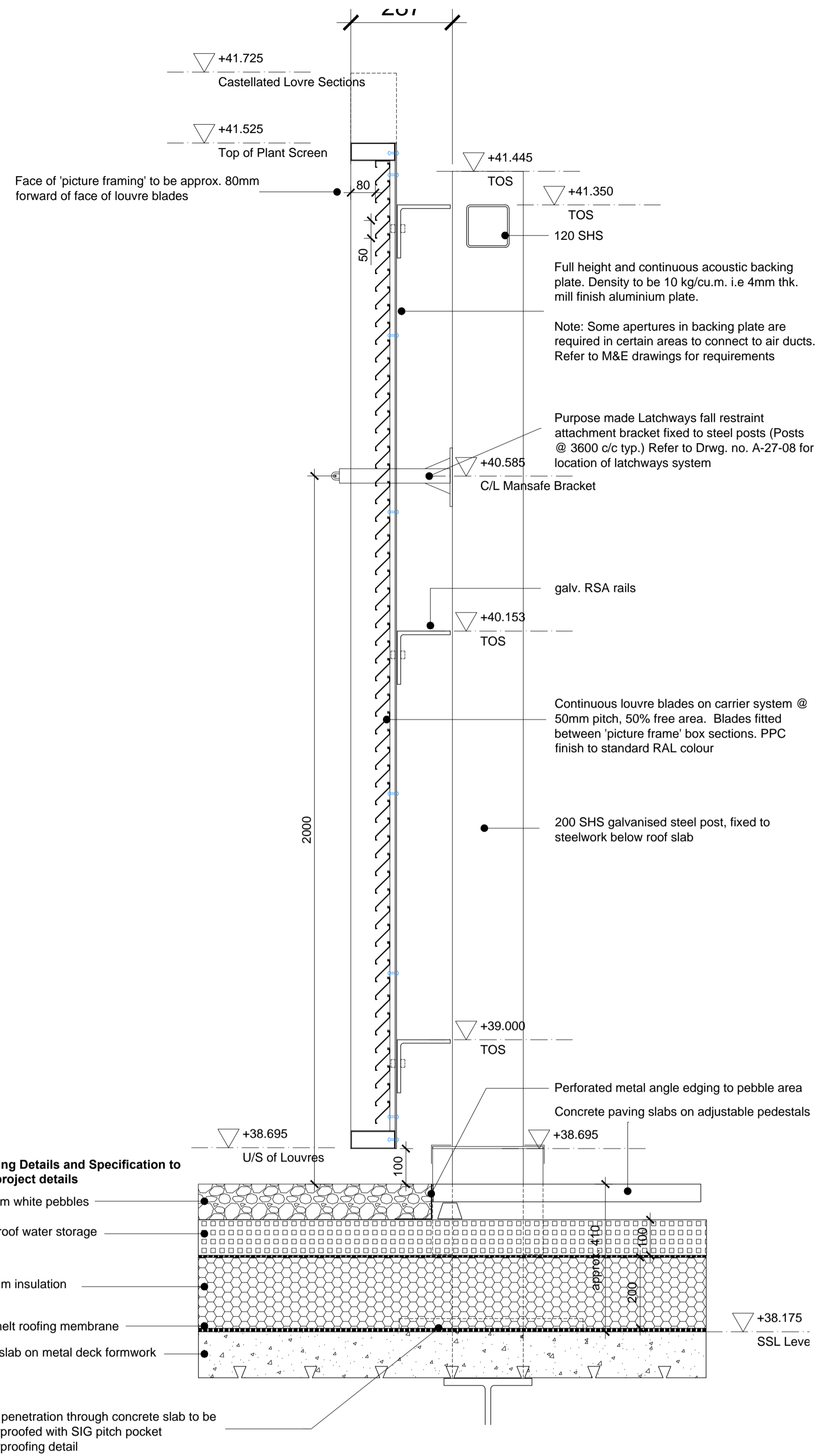

01 Charterhouse St. Plant Screen - Typ Section
A-21-DET-55 SCALE: 1:10

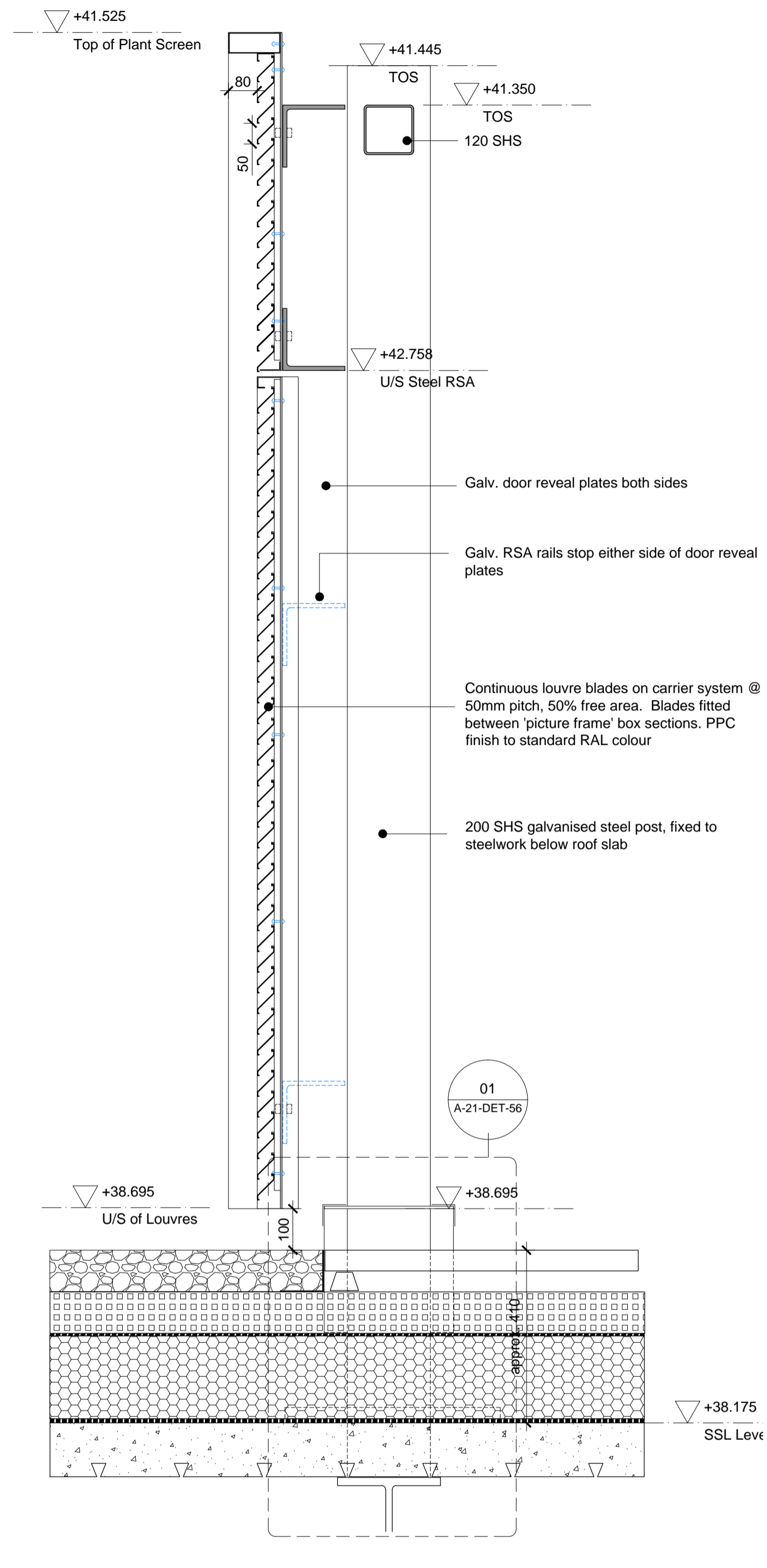

02 Charterhouse St. Plant Screen - Typ Section at Louvred Door
A-21-DET-55 SCALE: 1:10

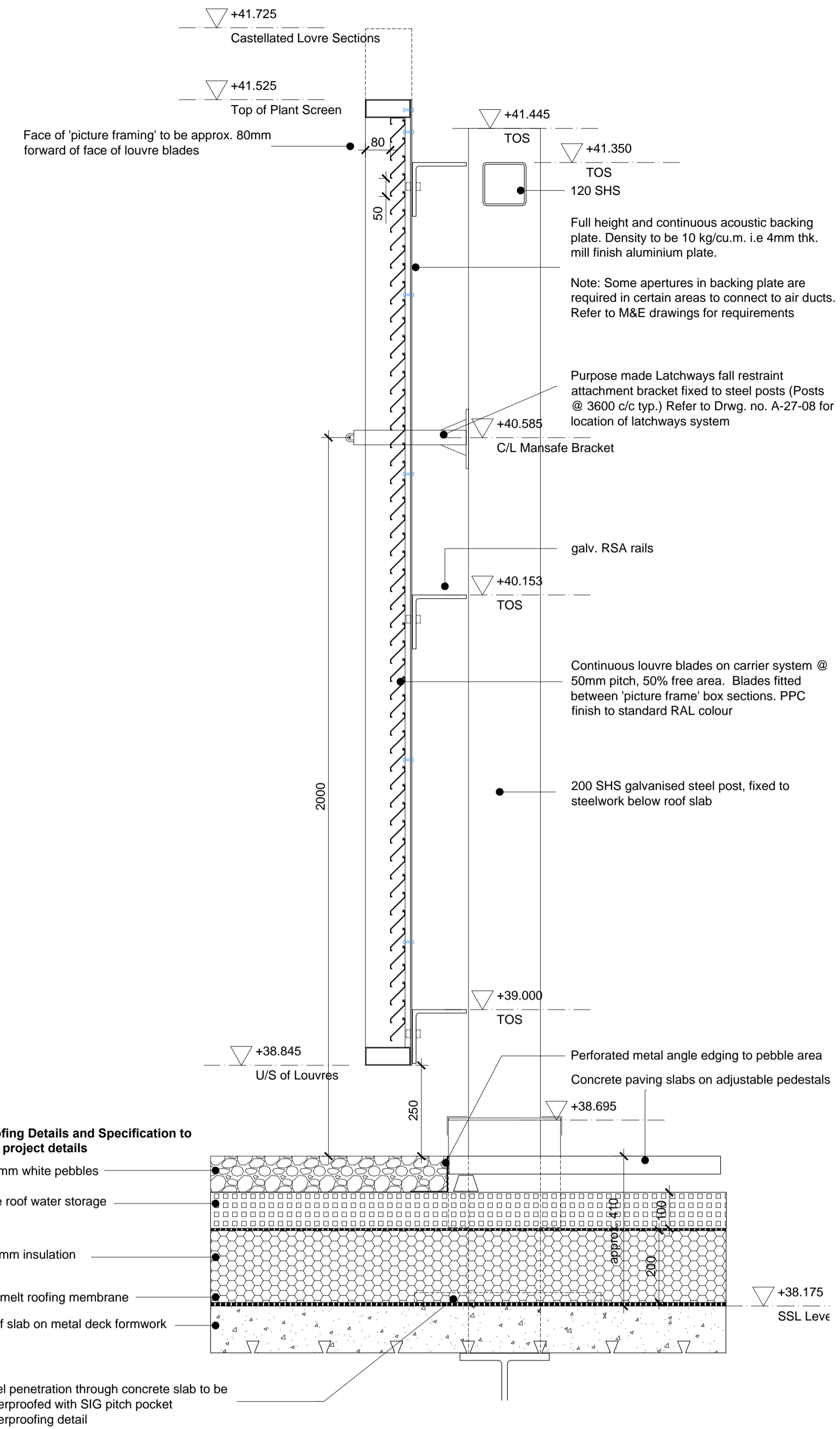

03 Charterhouse St. Plant Screen - Undercut Section Section
A-21-DET-55 SCALE: 1:10

Louvre Blade Systems

Louvres to be Rensen ref. Linius L.050.00 or equal and approved.

Louvre pitch = 50mm

Free Area = 50% or better

Colour: Standard RAL Colour - TBC.
Finish: matt

DETAIL SECTIONS; CHARTERHOUSE STREET PLANT SCREEN

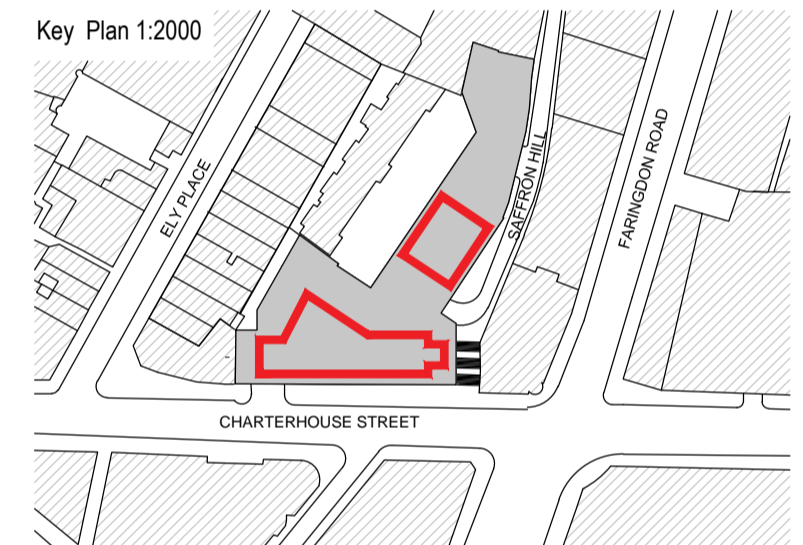
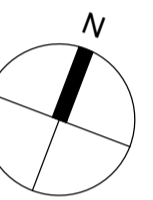

REV	DATE	PURPOSE OF ISSUE	BY
C1	27.02.19	ISSUED FOR CONSTRUCTION	SR
T2	07.08.18	Clarifications as per revision clouds	SR
T1	31.07.18	ISSUED FOR TENDER	SR

CLIENT AA/DB

PROJECT 17 CHARTERHOUSE ST. LONDON

DRAWING ROOF LEVEL LOUVRED SCREEN CHARTERHOUSE BLDG. - LVL 7

SCALE A1 @ 1:10, 1:20

CAD FILE Plant Screens.dwg

DRAWN RS

CHECKED SR

STATUS PRELIMINARY TENDER CONSTRUCTION AS BUILT

DRAWING NO. P17-082 A 21 DET 55 C1

MCM

MCM Architecture Limited T 020 7902 0900 F 020 7922 1233
71 Hopton Street London SE1 9LR www.mcm-uk.com

Louvre Blade Systems

Louvres to be Rensen ref. Linius L.050.00 or equal and approved.

Louvre pitch = 50mm

Free Area = 50% or better

Colour: Standard RAL Colour - TBC.
Finish: matt

DETAILS OF SAFFRON HILL AND CHARTERHOUSE STREET CORNER JUNCTIONS

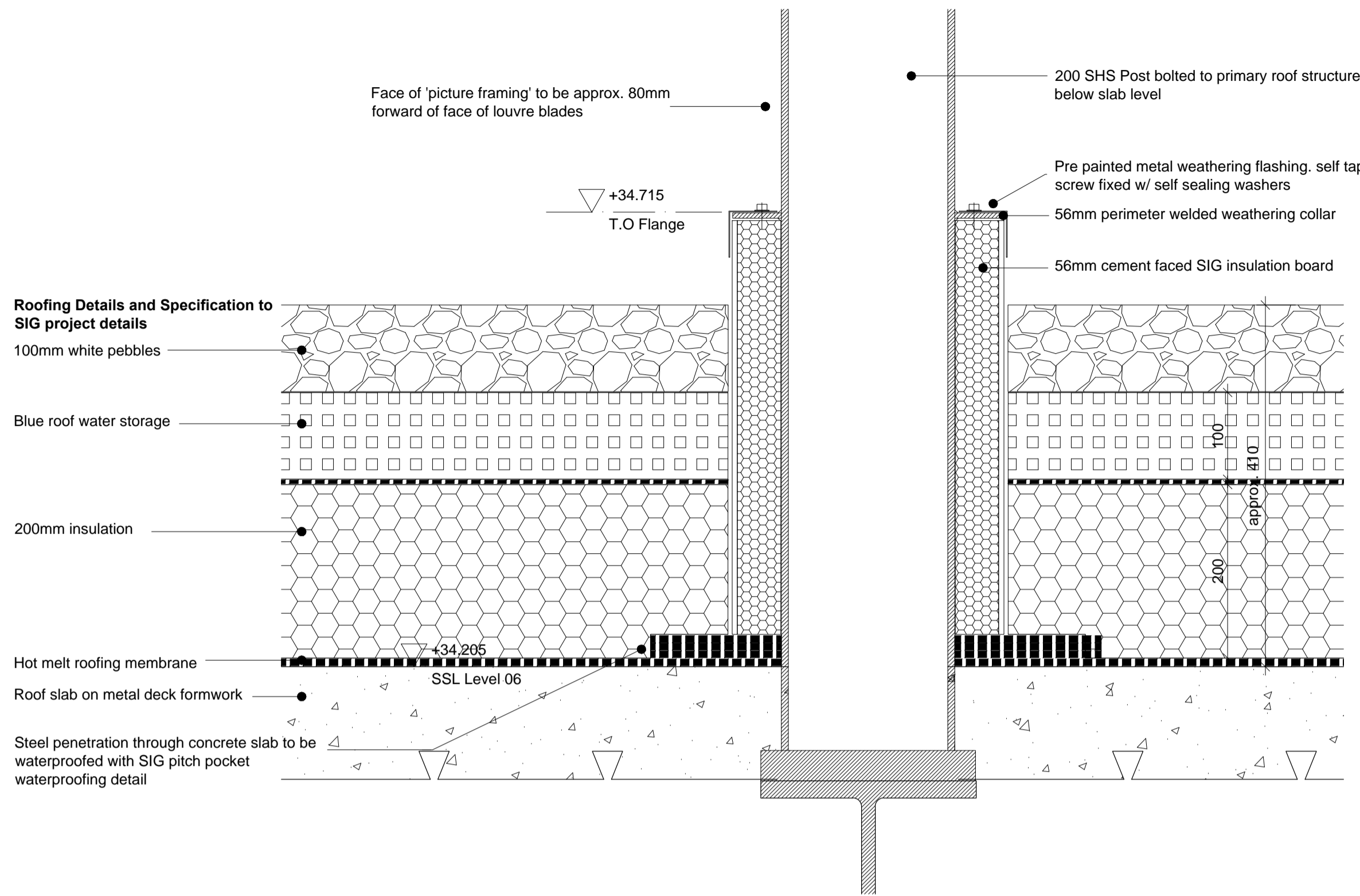

01 Plant Screen - Steel Post Base Details
A-21-DET-56 SCALE: 1:5

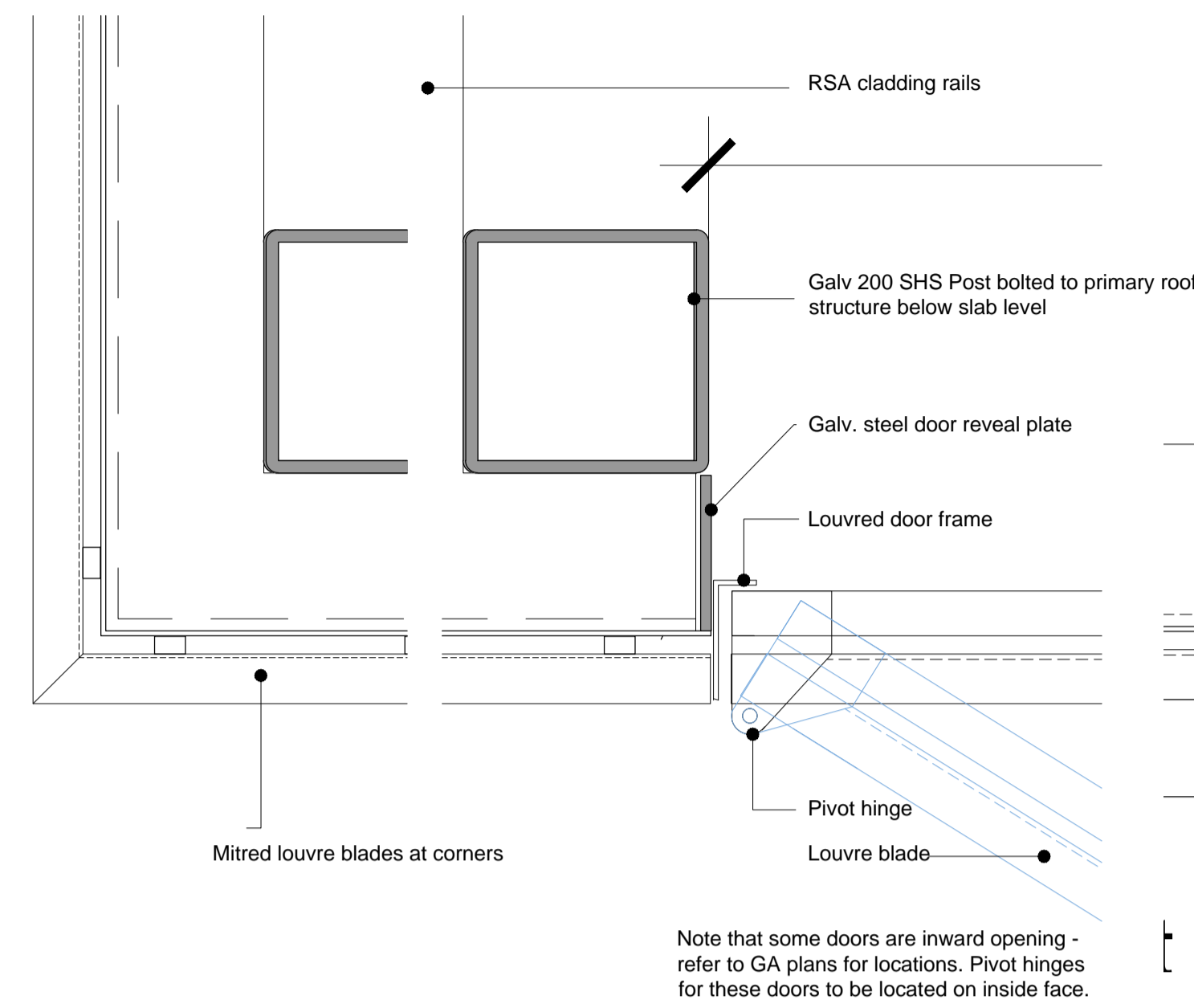

02 Saffron Hill Plant Screen - Corner / Door Detail
A-21-DET-58 SCALE: 1:5

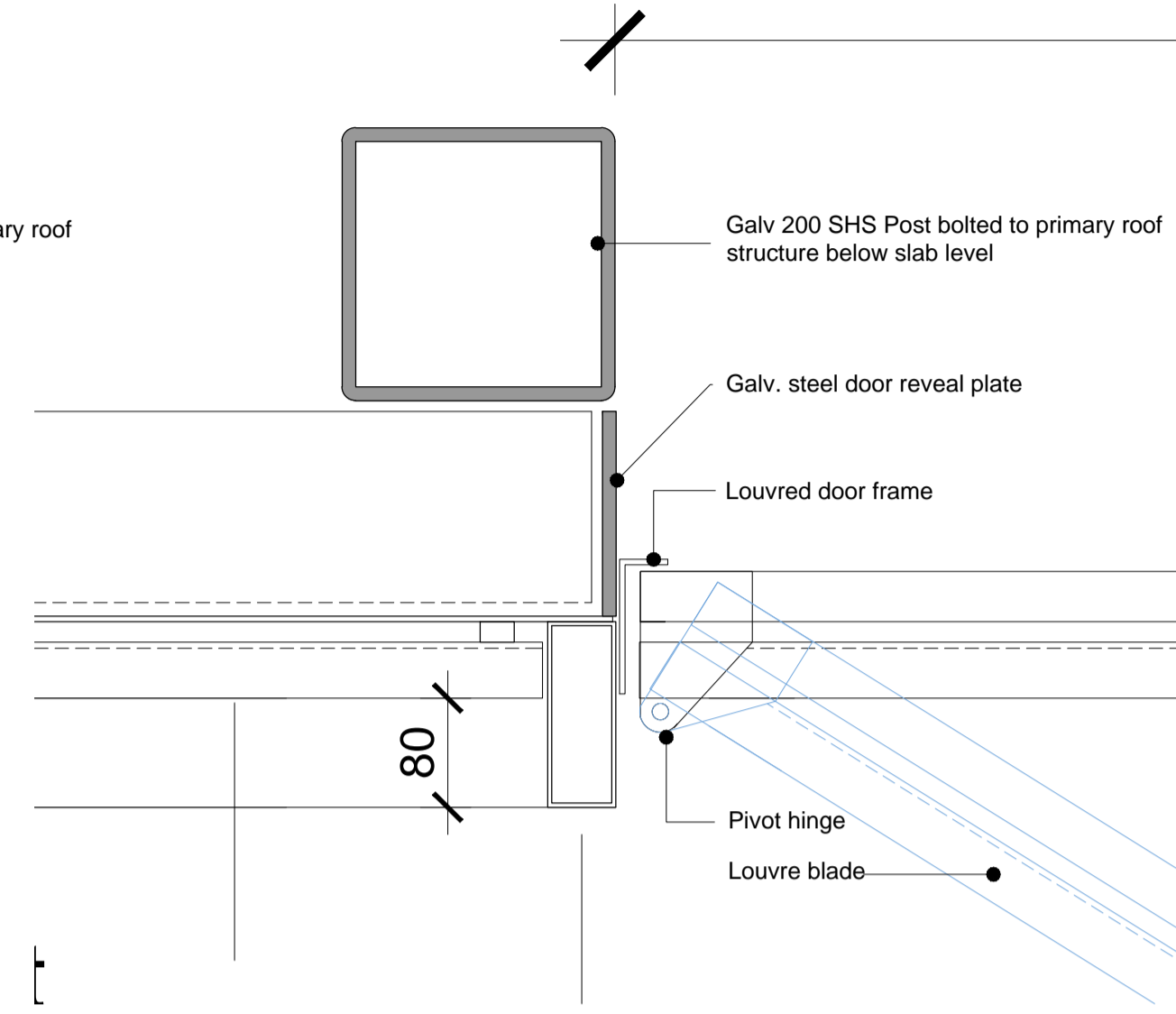

03 Charterhouse St. Plant Screen - Door Detail
A-21-DET-56 SCALE: 1:5

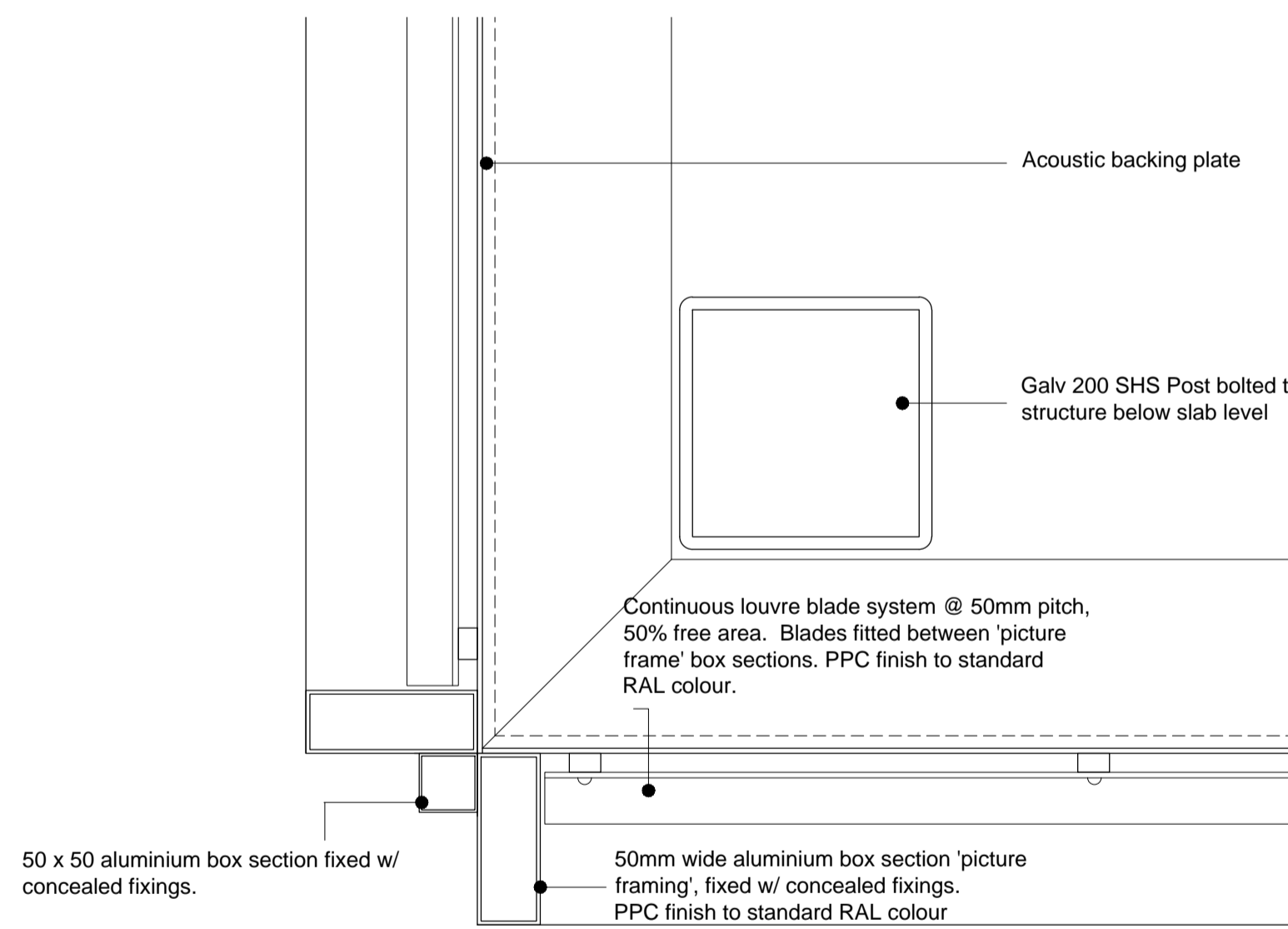
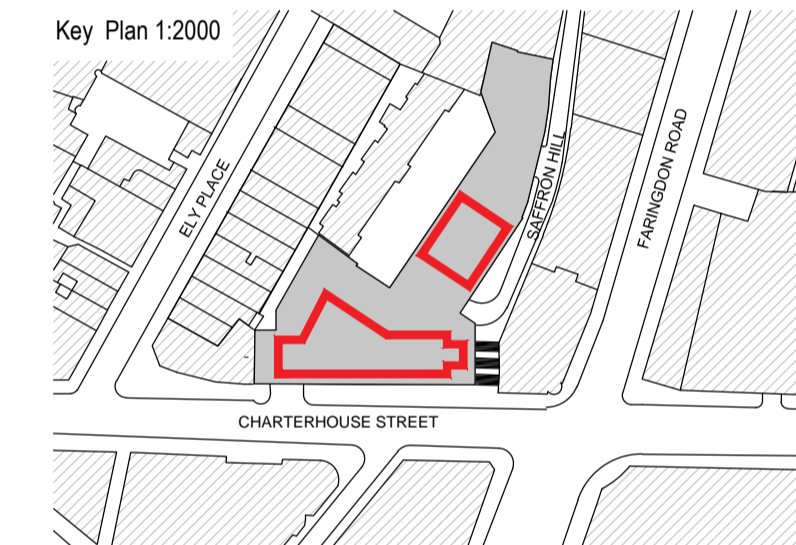

04 Charterhouse St. Plant Screen - Corner Detail
A-21-DET-56 SCALE: 1:5

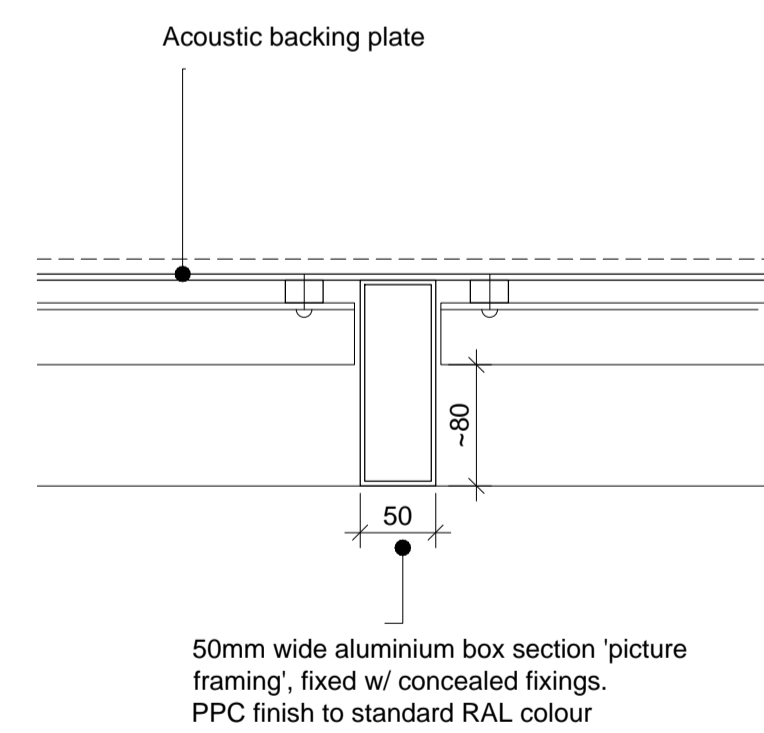

05 Charterhouse St. Plant Screen - Typ. Frame Detail
A-21-DET-56 SCALE: 1:5

REV	DATE	PURPOSE OF ISSUE	BY
C1	27.02.19	ISSUED FOR CONSTRUCTION	SR
T2	07.08.18	Clarifications as per revision clouds	SR
T1	31.07.18	ISSUED FOR TENDER	SR

CLIENT	AA/DB				
PROJECT	17 CHARTERHOUSE ST. LONDON				
DRAWING	ROOF LEVEL LOUVRED SCREEN CHARTERHOUSE BLDG. - LVL 7				
SCALE	A1 @ 1:10, 1:20				
CAD FILE	A-21-DET-52 to 56 - Plant Screens.dwg				
DRAWN	SR				
CHECKED	SR				
DRAWING NO.	P17-082 A 21 DET 56 C1				
proj.	blt.	series.	floor/type	no.	rev.
MCM					
MCM Architecture Limited T 020 7902 0900 F 020 7922 1233 71 Hopton Street London SE1 9LR www.mcm-uk.com					

DETAIL AT BASE OF VENTILATION LOUVRES, EWS05

ANODISED TO C33

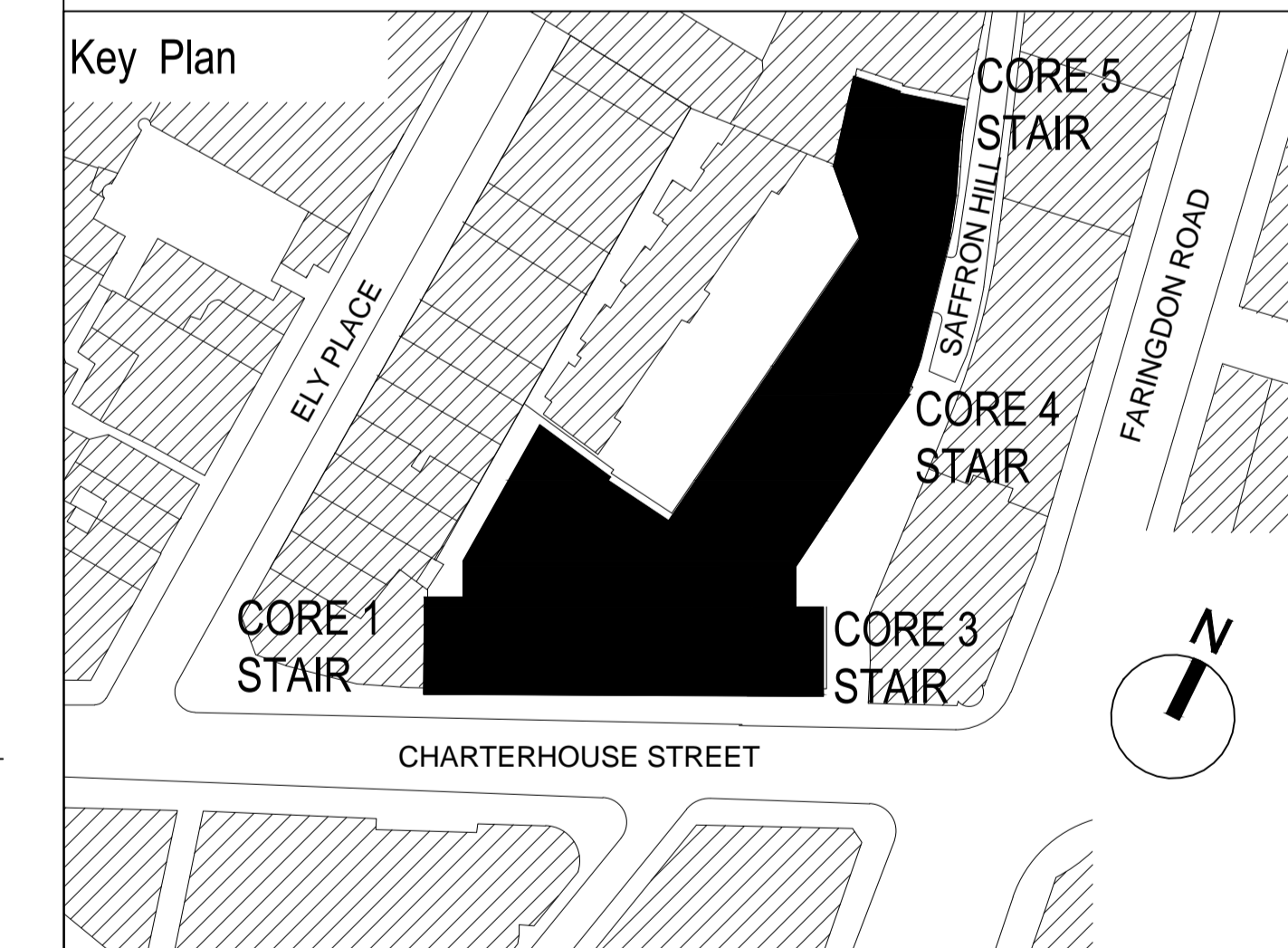
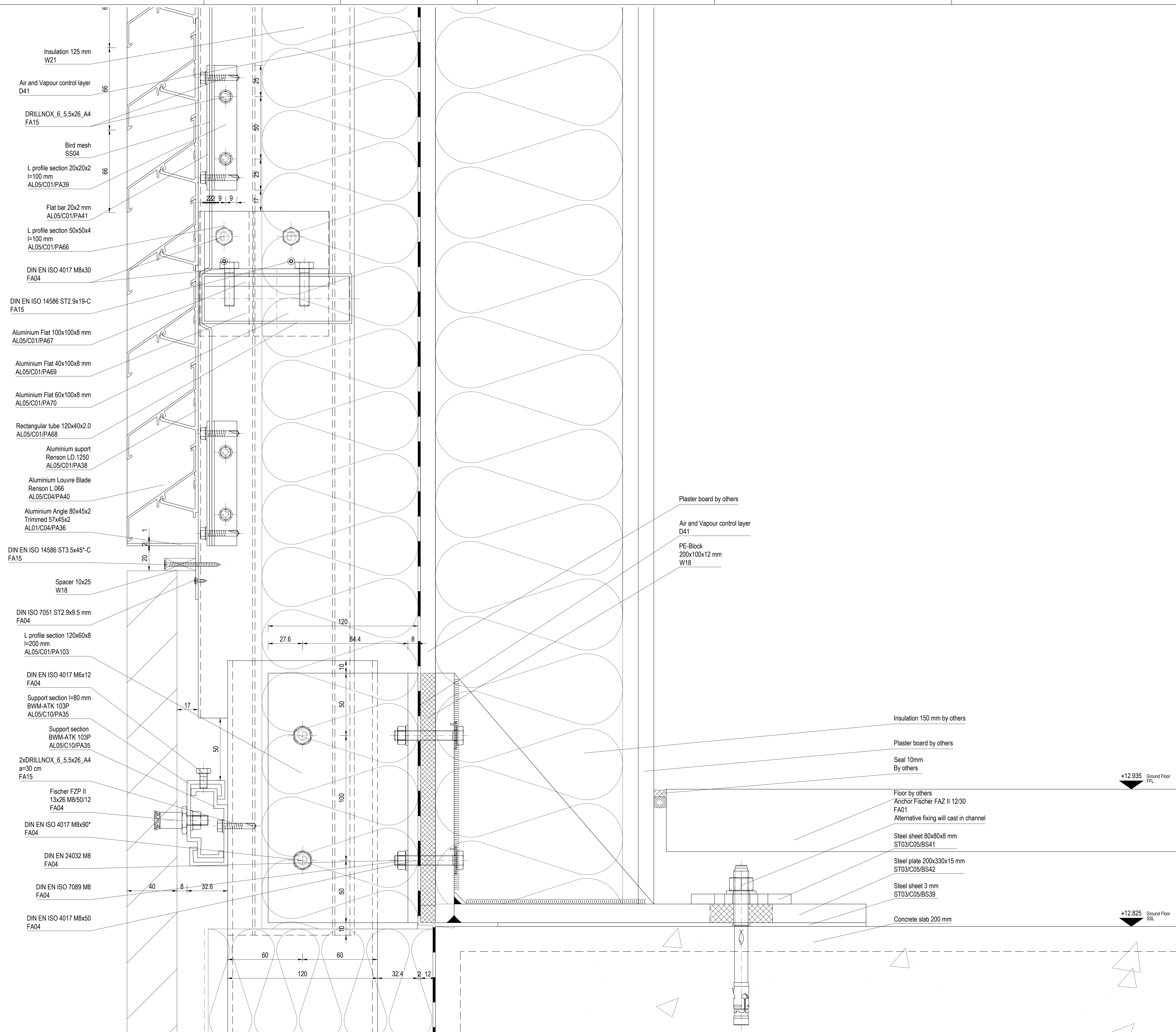

APPROVAL Status B
DATE: 16.12.2018

Rev	Revisions	Date	Drawn	Checked
C1	Approval Status B 16.12.2018; design adjusted	11-Jan-19	A. Figueroa	F. Schurig

SCHNEIDER **Schneider GB Ltd**
 Downstream Offices
 Builders Wharf West
 38 Shad Thames
 London, SE1 2YD
 t +44 (0) 20 7401 6383
 www.schneider-facades.co.uk

WINDOWS
FACADES
CURTAIN WALLING

JOB NO.: K30152
 CONTRACT: 17 Charterhouse Street
 ARCHITECTS: MCM Architecture Limited
 DRAWING TITLE: Main Work
 EWS-05
 Vertical section

Scale: A3, L3
 A0, 1:1
 Date: 19-NOV-18
 Checked-by: F.Schurig
 Drawn by: A. Figueroa
 Revision: C1

This drawing is our property. Each duplication, utilization or passing on to third persons is forbidden and will be pursued.

DETAIL OF TWO LOUVRE PANELS;
VENTILATION LOUVRES, EWS05

ANODISED TO C33

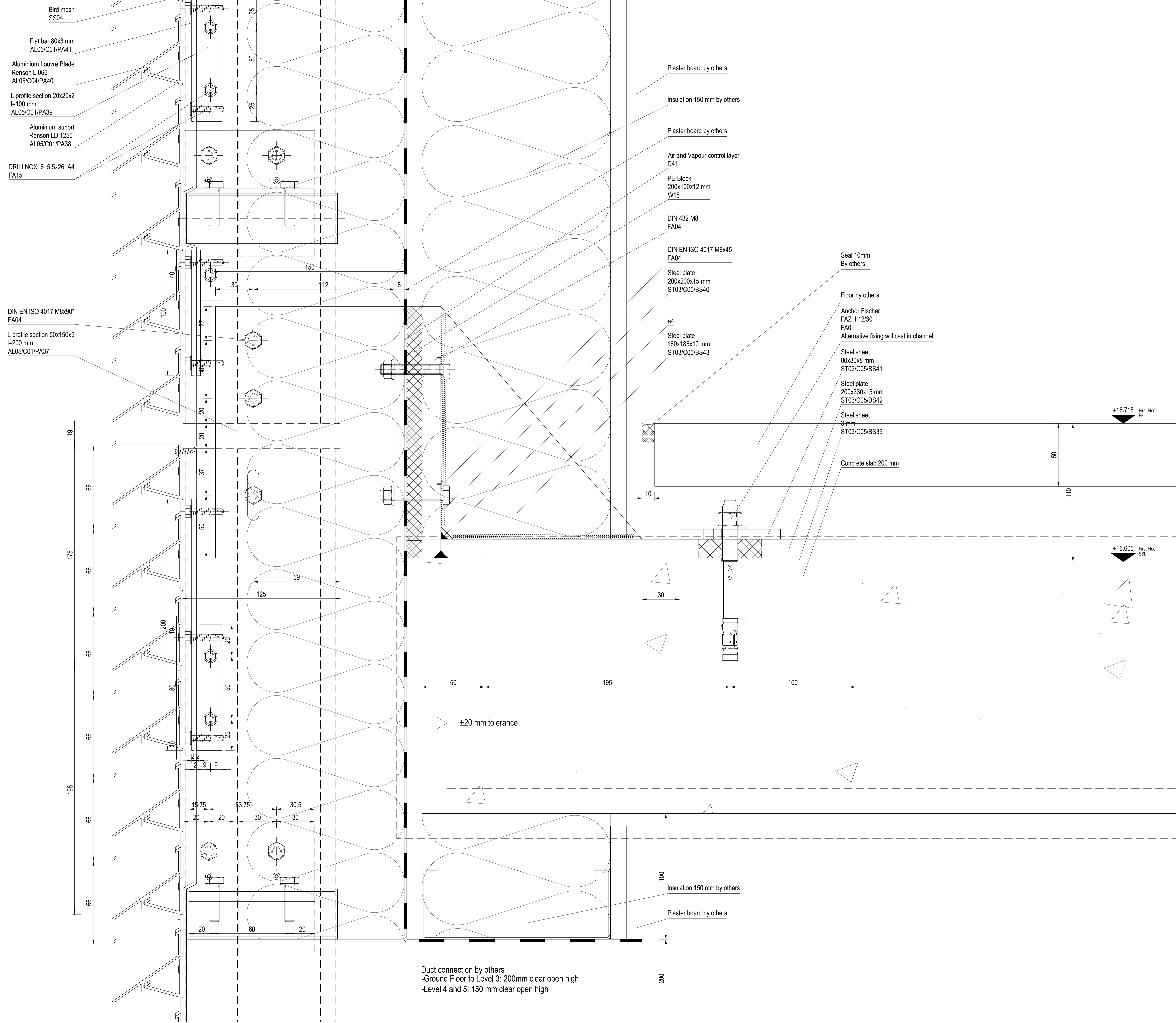

- Plaster board by others
- Insulation 150 mm by others
- Plaster board by others
- Air and Vapour control layer D41
- PE-Block 200x100x12 mm W18
- DIN 432 M8 FA04
- DIN EN ISO 4017 M8x45 FA04
- Steel plate 200x200x15 mm ST03/C05/BS40
- Seal 10mm By others
- Floor by others
- Anchor Fischer FAZ II 12/30 FA01 Alternative fixing will cast in channel
- Steel sheet 80x80x8 mm ST03/C05/BS41
- Steel plate 200x330x15 mm ST03/C05/BS42
- Steel sheet 3 mm ST03/C05/BS39
- Concrete slab 200 mm
- Steel plate 160x185x10 mm ST03/C05/BS43

- Bird mesh SS04
- Flat bar 80x3 mm AL05/C01/PA41
- Aluminium Louvre Blade Renson L.066 AL05/C04/PA40
- L profile section 20x20x2 l=100 mm AL05/C01/PA39
- Aluminium suport Renson LD.1250 AL05/C01/PA38
- DRILLNOX_6_5,5x26_A4 FA15
- DIN EN ISO 4017 M8x90* FA04
- L profile section 50x150x5 l=200 mm AL05/C01/PA37

Duct connection by others
-Ground Floor to Level 3: 200mm clear open high
-Level 4 and 5: 150 mm clear open high

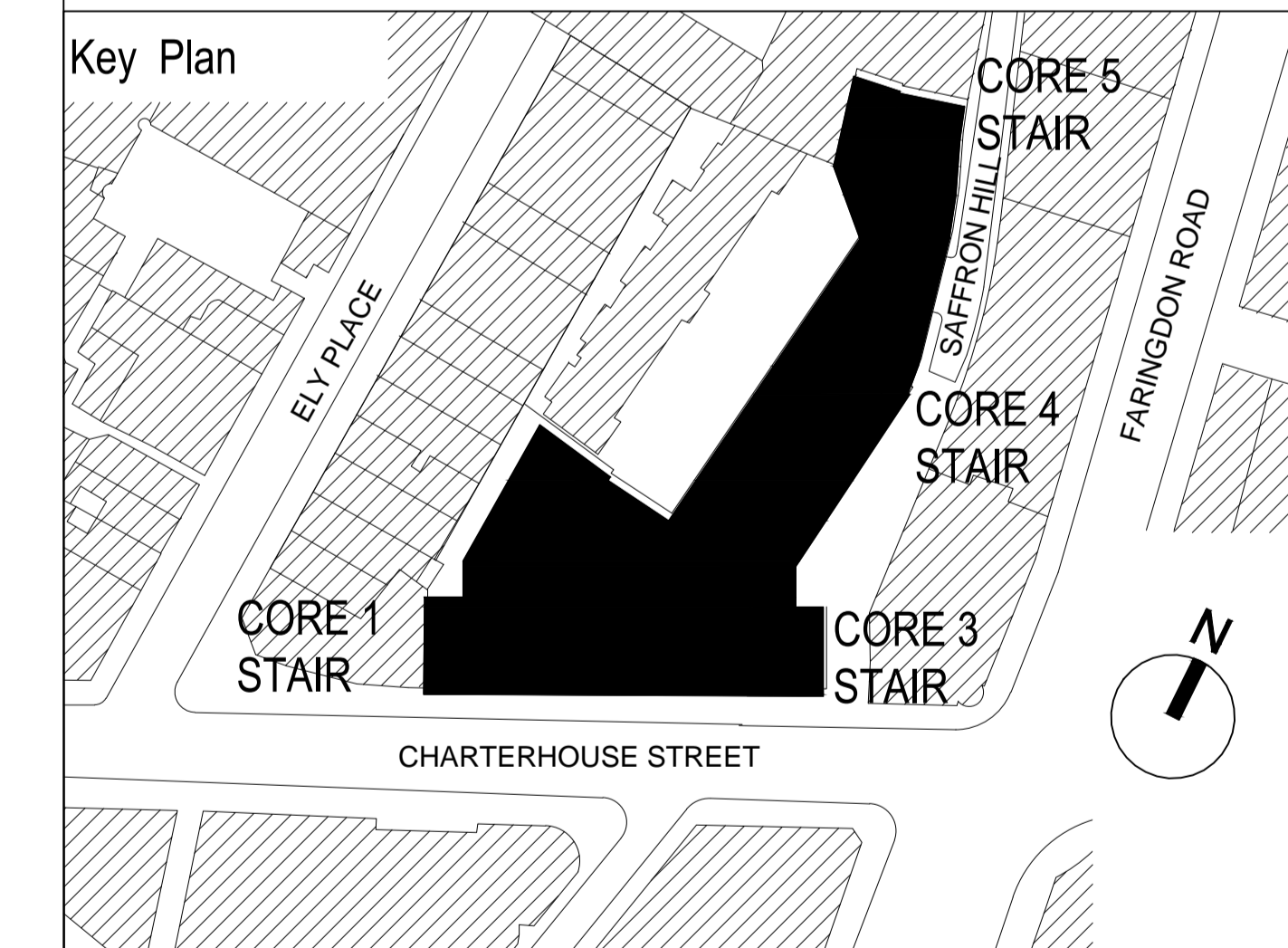

APPROVAL Status A
DATE: 16.12.2018

C7				
C6				
C5				
C4				
C3				
C2				
C1	Approval Status A	11-Jan-19	A. Figueroa	F. Schurig
Rev	Revisions	Date	Drawn	Checked

SCHNEIDER **Schneider GB Ltd**
Downstream Offices
Bullers Wharf West
38 Shed Thames
London, SE1 2YD
t +44 (0) 20 7401 6383
www.schneider-facades.co.uk

WINDOWS
FACADES
CURTAIN WALLING

JOB NO.: K30152
CONTRACT: 17 Charterhouse Street
ARCHITECTS: MCM Architecture Limited
DRAWING TITLE: Main Work
EWS-05
Vertical section

Scale: A3, L3
A0, 1:1
Date: 19-NOV-18
Checked-by: F.Schurig
Drawn by: A. Figueroa
Revision: C1

Drawing-Nr.: P2020-SGB-MW-05-D-01-013

This drawing is our property. Each duplication, utilization or passing on to third persons is forbidden and will be pursued.

TOP OF VENTILATION LOUVRE;
EWS05

ANODISED TO C33

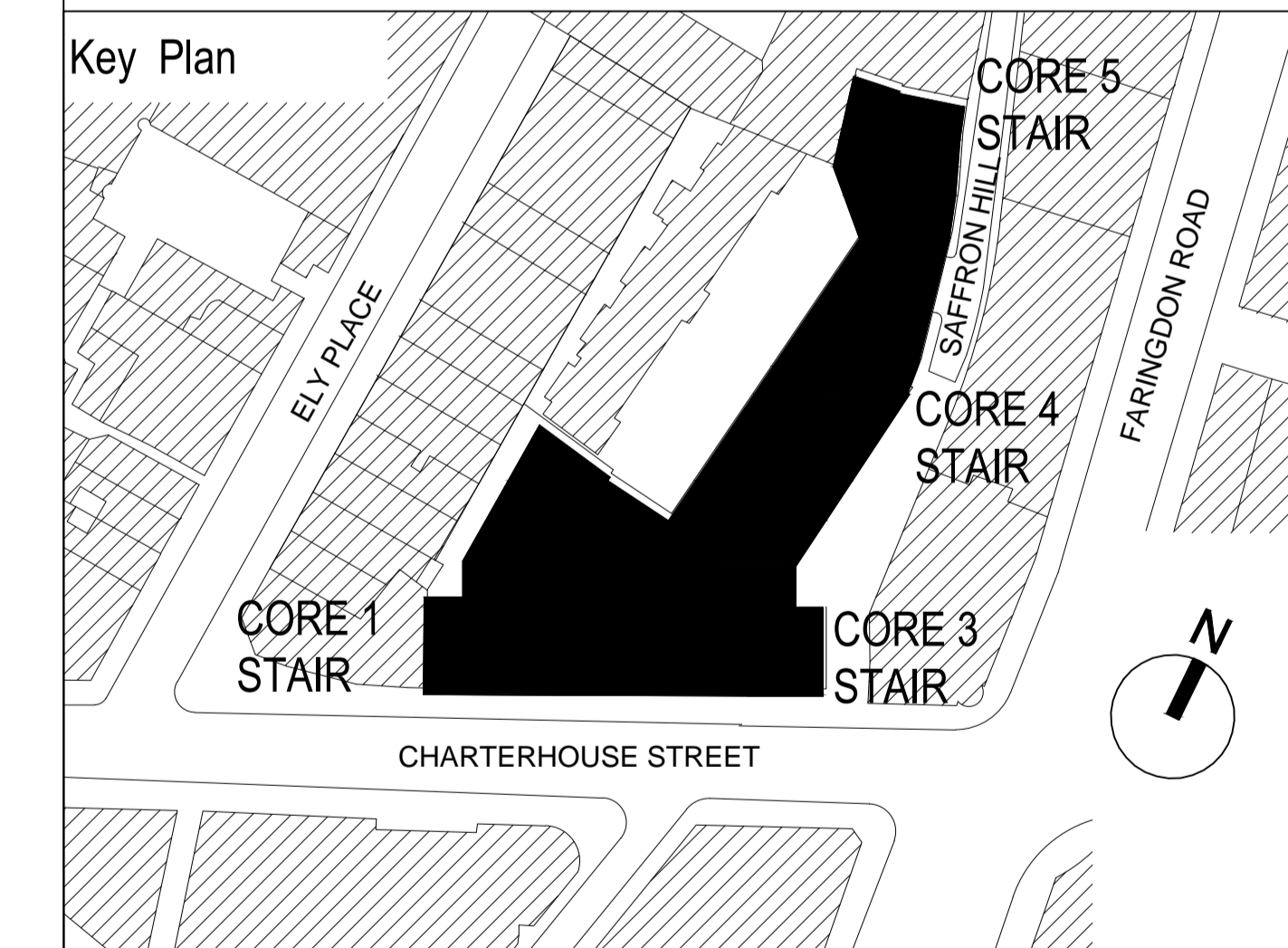
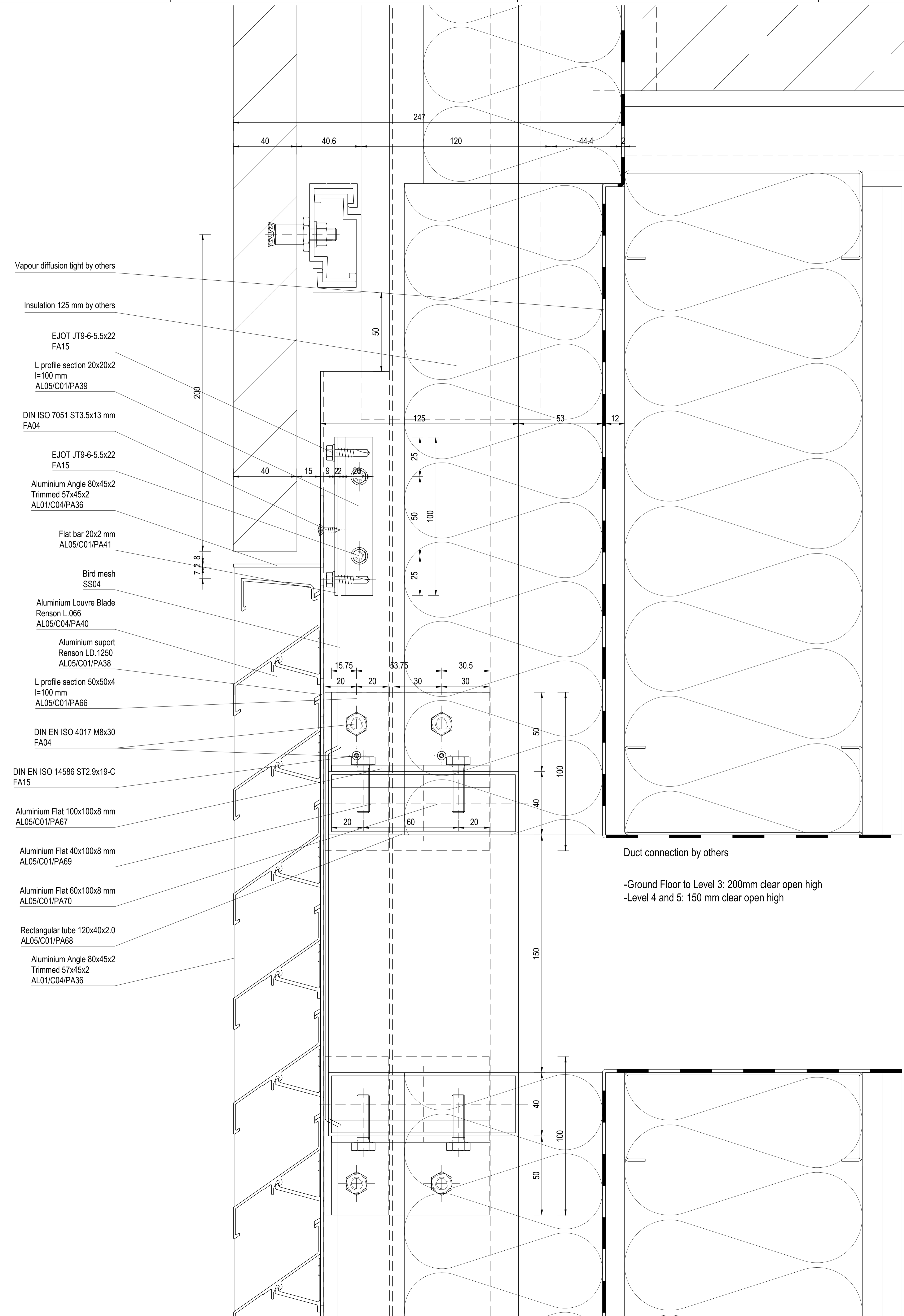

APPROVAL

DATE:

Rev	Revisions	Date	Drawn	Checked
C7				
C6				
C5				
C4				
C3				
C2				
C1				

SCHNEIDER **Schneider GB Ltd**
Downstream Offices
Bullers Wharf West
38 Shad Thames London, SE1 2YD
t +44 (0) 20 7401 6383
www.schneider-facades.co.uk

WINDOWS
FACADES
CURTAIN WALLING

JOB NO.: K30152
CONTRACT: 17 Charterhouse Street
ARCHITECTS: MCM Architecture Limited
DRAWING TITLE: Main Work
EWS-05
Vertical section

Scale: A3, A4, A5, A6, A7, A8, A9, A10, A11, A12, A13, A14, A15, A16, A17, A18, A19, A20, A21, A22, A23, A24, A25, A26, A27, A28, A29, A30, A31, A32, A33, A34, A35, A36, A37, A38, A39, A40, A41, A42, A43, A44, A45, A46, A47, A48, A49, A50, A51, A52, A53, A54, A55, A56, A57, A58, A59, A60, A61, A62, A63, A64, A65, A66, A67, A68, A69, A70, A71, A72, A73, A74, A75, A76, A77, A78, A79, A80, A81, A82, A83, A84, A85, A86, A87, A88, A89, A90, A91, A92, A93, A94, A95, A96, A97, A98, A99, A100, A101, A102, A103, A104, A105, A106, A107, A108, A109, A110, A111, A112, A113, A114, A115, A116, A117, A118, A119, A120, A121, A122, A123, A124, A125, A126, A127, A128, A129, A130, A131, A132, A133, A134, A135, A136, A137, A138, A139, A140, A141, A142, A143, A144, A145, A146, A147, A148, A149, A150, A151, A152, A153, A154, A155, A156, A157, A158, A159, A160, A161, A162, A163, A164, A165, A166, A167, A168, A169, A170, A171, A172, A173, A174, A175, A176, A177, A178, A179, A180, A181, A182, A183, A184, A185, A186, A187, A188, A189, A190, A191, A192, A193, A194, A195, A196, A197, A198, A199, A200, A201, A202, A203, A204, A205, A206, A207, A208, A209, A210, A211, A212, A213, A214, A215, A216, A217, A218, A219, A220, A221, A222, A223, A224, A225, A226, A227, A228, A229, A230, A231, A232, A233, A234, A235, A236, A237, A238, A239, A240, A241, A242, A243, A244, A245, A246, A247, A248, A249, A250, A251, A252, A253, A254, A255, A256, A257, A258, A259, A260, A261, A262, A263, A264, A265, A266, A267, A268, A269, A270, A271, A272, A273, A274, A275, A276, A277, A278, A279, A280, A281, A282, A283, A284, A285, A286, A287, A288, A289, A290, A291, A292, A293, A294, A295, A296, A297, A298, A299, A300, A301, A302, A303, A304, A305, A306, A307, A308, A309, A310, A311, A312, A313, A314, A315, A316, A317, A318, A319, A320, A321, A322, A323, A324, A325, A326, A327, A328, A329, A330, A331, A332, A333, A334, A335, A336, A337, A338, A339, A340, A341, A342, A343, A344, A345, A346, A347, A348, A349, A350, A351, A352, A353, A354, A355, A356, A357, A358, A359, A360, A361, A362, A363, A364, A365, A366, A367, A368, A369, A370, A371, A372, A373, A374, A375, A376, A377, A378, A379, A380, A381, A382, A383, A384, A385, A386, A387, A388, A389, A390, A391, A392, A393, A394, A395, A396, A397, A398, A399, A400, A401, A402, A403, A404, A405, A406, A407, A408, A409, A410, A411, A412, A413, A414, A415, A416, A417, A418, A419, A420, A421, A422, A423, A424, A425, A426, A427, A428, A429, A430, A431, A432, A433, A434, A435, A436, A437, A438, A439, A440, A441, A442, A443, A444, A445, A446, A447, A448, A449, A450, A451, A452, A453, A454, A455, A456, A457, A458, A459, A460, A461, A462, A463, A464, A465, A466, A467, A468, A469, A470, A471, A472, A473, A474, A475, A476, A477, A478, A479, A480, A481, A482, A483, A484, A485, A486, A487, A488, A489, A490, A491, A492, A493, A494, A495, A496, A497, A498, A499, A500, A501, A502, A503, A504, A505, A506, A507, A508, A509, A510, A511, A512, A513, A514, A515, A516, A517, A518, A519, A520, A521, A522, A523, A524, A525, A526, A527, A528, A529, A530, A531, A532, A533, A534, A535, A536, A537, A538, A539, A540, A541, A542, A543, A544, A545, A546, A547, A548, A549, A550, A551, A552, A553, A554, A555, A556, A557, A558, A559, A560, A561, A562, A563, A564, A565, A566, A567, A568, A569, A570, A571, A572, A573, A574, A575, A576, A577, A578, A579, A580, A581, A582, A583, A584, A585, A586, A587, A588, A589, A590, A591, A592, A593, A594, A595, A596, A597, A598, A599, A600, A601, A602, A603, A604, A605, A606, A607, A608, A609, A610, A611, A612, A613, A614, A615, A616, A617, A618, A619, A620, A621, A622, A623, A624, A625, A626, A627, A628, A629, A630, A631, A632, A633, A634, A635, A636, A637, A638, A639, A640, A641, A642, A643, A644, A645, A646, A647, A648, A649, A650, A651, A652, A653, A654, A655, A656, A657, A658, A659, A660, A661, A662, A663, A664, A665, A666, A667, A668, A669, A670, A671, A672, A673, A674, A675, A676, A677, A678, A679, A680, A681, A682, A683, A684, A685, A686, A687, A688, A689, A690, A691, A692, A693, A694, A695, A696, A697, A698, A699, A700, A701, A702, A703, A704, A705, A706, A707, A708, A709, A710, A711, A712, A713, A714, A715, A716, A717, A718, A719, A720, A721, A722, A723, A724, A725, A726, A727, A728, A729, A730, A731, A732, A733, A734, A735, A736, A737, A738, A739, A740, A741, A742, A743, A744, A745, A746, A747, A748, A749, A750, A751, A752, A753, A754, A755, A756, A757, A758, A759, A760, A761, A762, A763, A764, A765, A766, A767, A768, A769, A770, A771, A772, A773, A774, A775, A776, A777, A778, A779, A780, A781, A782, A783, A784, A785, A786, A787, A788, A789, A790, A791, A792, A793, A794, A795, A796, A797, A798, A799, A800, A801, A802, A803, A804, A805, A806, A807, A808, A809, A810, A811, A812, A813, A814, A815, A816, A817, A818, A819, A820, A821, A822, A823, A824, A825, A826, A827, A828, A829, A830, A831, A832, A833, A834, A835, A836, A837, A838, A839, A840, A841, A842, A843, A844, A845, A846, A847, A848, A849, A850, A851, A852, A853, A854, A855, A856, A857, A858, A859, A860, A861, A862, A863, A864, A865, A866, A867, A868, A869, A870, A871, A872, A873, A874, A875, A876, A877, A878, A879, A880, A881, A882, A883, A884, A885, A886, A887, A888, A889, A890, A891, A892, A893, A894, A895, A896, A897, A898, A899, A900, A901, A902, A903, A904, A905, A906, A907, A908, A909, A910, A911, A912, A913, A914, A915, A916, A917, A918, A919, A920, A921, A922, A923, A924, A925, A926, A927, A928, A929, A930, A931, A932, A933, A934, A935, A936, A937, A938, A939, A940, A941, A942, A943, A944, A945, A946, A947, A948, A949, A950, A951, A952, A953, A954, A955, A956, A957, A958, A959, A960, A961, A962, A963, A964, A965, A966, A967, A968, A969, A970, A971, A972, A973, A974, A975, A976, A977, A978, A979, A980, A981, A982, A983, A984, A985, A986, A987, A988, A989, A990, A991, A992, A993, A994, A995, A996, A997, A998, A999, A1000, A1001, A1002, A1003, A1004, A1005, A1006, A1007, A1008, A1009, A1010, A1011, A1012, A1013, A1014, A1015, A1016, A1017, A1018, A1019, A1020, A1021, A1022, A1023, A1024, A1025, A1026, A1027, A1028, A1029, A1030, A1031, A1032, A1033, A1034, A1035, A1036, A1037, A1038, A1039, A1040, A1041, A1042, A1043, A1044, A1045, A1046, A1047, A1048, A1049, A1050, A1051, A1052, A1053, A1054, A1055, A1056, A1057, A1058, A1059, A1060, A1061, A1062, A1063, A1064, A1065, A1066, A1067, A1068, A1069, A1070, A1071, A1072, A1073, A1074, A1075, A1076, A1077, A1078, A1079, A1080, A1081, A1082, A1083, A1084, A1085, A1086, A1087, A1088, A1089, A1090, A1091, A1092, A1093, A1094, A1095, A1096, A1097, A1098, A1099, A1100, A1101, A1102, A1103, A1104, A1105, A1106, A1107, A1108, A1109, A1110, A1111, A1112, A1113, A1114, A1115, A1116, A1117, A1118, A1119, A1120, A1121, A1122, A1123, A1124, A1125, A1126, A1127, A1128, A1129, A1130, A1131, A1132, A1133, A1134, A1135, A1136, A1137, A1138, A1139, A1140, A1141, A1142, A1143, A1144, A1145, A1146, A1147, A1148, A1149, A1150, A1151, A1152, A1153, A1154, A1155, A1156, A1157, A1158, A1159, A1160, A1161, A1162, A1163, A1164, A1165, A1166, A1167, A1168, A1169, A1170, A1171, A1172, A1173, A1174, A1175, A1176, A1177, A1178, A1179, A1180, A1181, A1182, A1183, A1184, A1185, A1186, A1187, A1188, A1189, A1190, A1191, A1192, A1193, A1194, A1195, A1196, A1197, A1198, A1199, A1200, A1201, A1202, A1203, A1204, A1205, A1206, A1207, A1208, A1209, A1210, A1211, A1212, A1213, A1214, A1215, A1216, A1217, A1218, A1219, A1220, A1221, A1222, A1223, A1224, A1225, A1226, A1227, A1228, A1229, A1230, A1231, A1232, A1233, A1234, A1235, A1236, A1237, A1238, A1239, A1240, A1241, A1242, A1243, A1244, A1245, A1246, A1247, A1248, A1249, A1250, A1251, A1252, A1253, A1254, A1255, A1256, A1257, A1258, A1259, A1260, A1261, A1262, A1263, A1264, A1265, A1266, A1267, A1268, A1269, A1270, A1271, A1272, A1273, A1274, A1275, A1276, A1277, A1278, A1279, A1280, A1281, A1282, A1283, A1284, A1285, A1286, A1287, A1288, A1289, A1290, A1291, A1292, A1293, A1294, A1295, A1296, A1297, A1298, A1299, A1300, A1301, A1302, A1303, A1304, A1305, A1306, A1307, A1308, A1309, A1310, A1311, A1312, A1313, A1314, A1315, A1316, A1317, A1318, A1319, A1320, A1321, A1322, A1323, A1324, A1325, A1326, A1327, A1328, A1329, A1330, A1331, A1332, A1333, A1334, A1335, A1336, A1337, A1338, A1339, A1340, A1341, A1342, A1343, A1344, A1345, A1346, A1347, A1348, A1349, A1350, A1351, A1352, A1353, A1354, A1355, A1356, A1357, A1358, A1359, A1360, A1361, A1362, A1363, A1364, A1365, A1366, A1367, A1368, A1369, A1370, A1371, A1372, A1373, A1374, A1375, A1376, A1377, A1378, A1379, A1380, A1381, A1382, A1383, A1384, A1385, A1386, A1387, A1388, A1389, A1390, A1391, A1392, A1393, A1394, A1395, A1396, A1397, A1398, A1399, A1400, A1401, A1402, A1403, A1404, A1405, A1406, A1407, A1408, A1409, A1410, A1411, A1412, A1413, A1414, A1415, A1416, A1417, A1418, A1419, A1420, A1421, A1422, A1423, A1424, A1425, A1426, A1427, A1428, A1429, A1430, A1431, A1432, A1433, A1434, A1435, A1436, A1437, A1438, A1439, A1440, A1441, A1442, A1443, A1444, A1445, A1446, A1447, A1448, A1449, A1450, A1451, A1452, A1453, A1454, A1455, A1456, A1457, A1458, A1459, A1460, A1461, A1462, A1463, A1464, A1465, A1466, A1467, A1468, A1469, A1470, A1471, A1472, A1473, A1474, A1475, A1476, A1477, A1478, A1479, A1480, A1481, A1482, A1483, A1484, A1485, A1486, A1487, A1488, A1489, A1490, A1491, A1492, A1493, A1494, A1495, A1496, A1497, A1498, A1499, A1500, A1501, A1502, A1503, A1504, A1505, A1506, A1507, A1508, A1509, A1510, A1511, A1512, A1513, A1514, A1515, A1516, A1517, A1518, A1519, A1520, A1521, A1522, A1523, A1524, A1525, A1526, A1527, A1528, A1529, A1530, A1531, A1532, A1533, A1534, A1535, A1536, A1537, A1538, A1539, A1540, A1541, A1542, A1543, A1544, A1545, A1546, A1547, A1548, A1549, A1550, A1551, A1552, A1553, A1554, A1555, A1556, A1557, A1558, A1559, A1560, A1561, A1562, A1563, A1564, A1565, A1566, A1567, A1568, A1569, A1570, A1571, A1572, A1573, A1574, A1575, A1576, A1577, A1578, A1579, A1580, A1581, A1582, A1583, A1584, A1585, A1586, A1587, A1588, A1589, A1590, A1591, A1592, A1593, A1594, A1595, A1596, A1597, A1598, A1599, A1600, A1601, A1602, A1603, A1604, A1605, A1606, A1607, A1608, A1609, A1610, A1611, A1612, A1613, A1614, A1615, A1616, A1617, A1618, A1619, A1620, A1621, A1622, A1623, A1624, A1625, A1626, A1627, A1628, A1629, A1630, A1631, A1632, A1633, A1634, A1635, A1636, A1637, A1638, A1639, A1640, A1641, A1642, A1643, A1644, A1645, A1646, A1647, A1648, A1649, A1650, A1651, A1652, A1653, A1654, A1655, A1656, A1657, A1658, A1659, A1660, A1661, A1662, A1663, A1664, A1665, A1666, A1667, A1668, A1669, A1670, A1671, A1672, A1673, A1674, A1675, A1676, A1677, A1678, A1679, A1680, A1681, A1682, A1683, A1684, A1685, A1686, A1687, A1688, A1689, A1690, A1691, A1692, A1693, A1694, A1695, A1696, A1697, A1698, A1699, A1700, A1701, A1702, A1703, A1704, A1705, A1706, A1707, A1708, A1709, A1710, A1711, A1712, A1713, A1714, A1715, A1716, A1717, A1718, A1719, A1720, A1721, A1722, A1723, A1724, A1725, A1726, A1727, A1728, A1729, A1730, A1731, A1732, A1733, A1734, A1735, A1736, A1737, A1738, A1739, A1740, A1741, A1742, A1743, A1744, A1745, A1746, A1747, A1748, A1749, A1750, A1751, A1752, A1753, A1754, A1755, A1756, A1757, A1758, A1759, A1760, A1761, A1762, A1763, A1764, A1765, A1766, A1767, A1768, A1769, A1770, A1771, A1772, A1773, A1774, A1775, A1776, A1777, A1778, A1779, A1780, A1781, A1782, A1783, A1784, A1785, A1786, A1787, A1788, A1789, A1790, A1791, A1792, A1793, A1794, A1795, A1796, A1797, A1798, A1799, A1800, A1801, A1802, A1803, A1804, A1805, A1806, A1807, A1808, A1809, A1810, A1811, A1812, A1813, A1814, A1815, A1816, A1817, A1818, A1819, A1820, A1821, A1822, A1823, A1824, A1825, A1826, A1827, A1828, A1829, A1830, A1831, A1832, A1833, A1834, A1835, A1836, A1837, A1838, A1839, A1840, A1841, A1842, A1843, A1844, A1845, A1846, A1847, A1848, A1849, A1850, A1851, A1852, A1853, A1854, A1855, A1856, A1857, A1858, A1859, A1860, A1861, A1862, A1863, A1864, A1865, A1866, A1867, A1868, A1869, A1870, A1871, A1872, A1873, A1874, A1875, A1876, A1877, A1878, A1879, A1880, A1881, A1882, A1883, A1884, A1885, A1886, A1887, A1888, A1889, A1890, A1891, A1892, A1893, A1894, A1895, A1896, A1897, A1898, A1899, A1900, A1901, A1902, A1903, A1904, A1905, A1906, A1907, A1908, A1909, A1910, A1911, A1912, A1913, A1914, A1915, A1916, A1917, A1918, A1919, A1920, A1921, A1922, A1923, A1924, A1925, A1926, A1927, A1928, A1929, A1930, A1931, A1932, A1933, A1934, A1935, A1936, A1937, A1938, A1939, A1940, A1941, A1942, A1943, A1944, A1945, A1946, A1947, A1948, A1949, A1950, A1951, A1952, A1953, A1954, A1955, A1956, A1957, A1958, A1959, A1960, A1961, A1962, A1963, A1964, A1965, A1966, A1967, A1968, A1969, A1970, A1971, A1972, A1973, A1974, A1975, A1976, A1977, A1978, A1979, A1980, A1981, A1982, A1983, A1984, A1985, A1986, A1987, A1988, A1989, A1990, A1991, A1992, A1993, A1994, A1995, A1996, A1997, A1998, A1999, A2000, A2001, A2002, A2003, A2004, A2005, A2006, A2007, A2008, A2009, A2010, A2011, A2012, A2013, A2014, A2015, A2016, A2017, A2018, A2019

PLAN VIEW; EDGE OF VENTILATION LOUVRE SET INTO STONE, EWS05

ANODISED TO C33

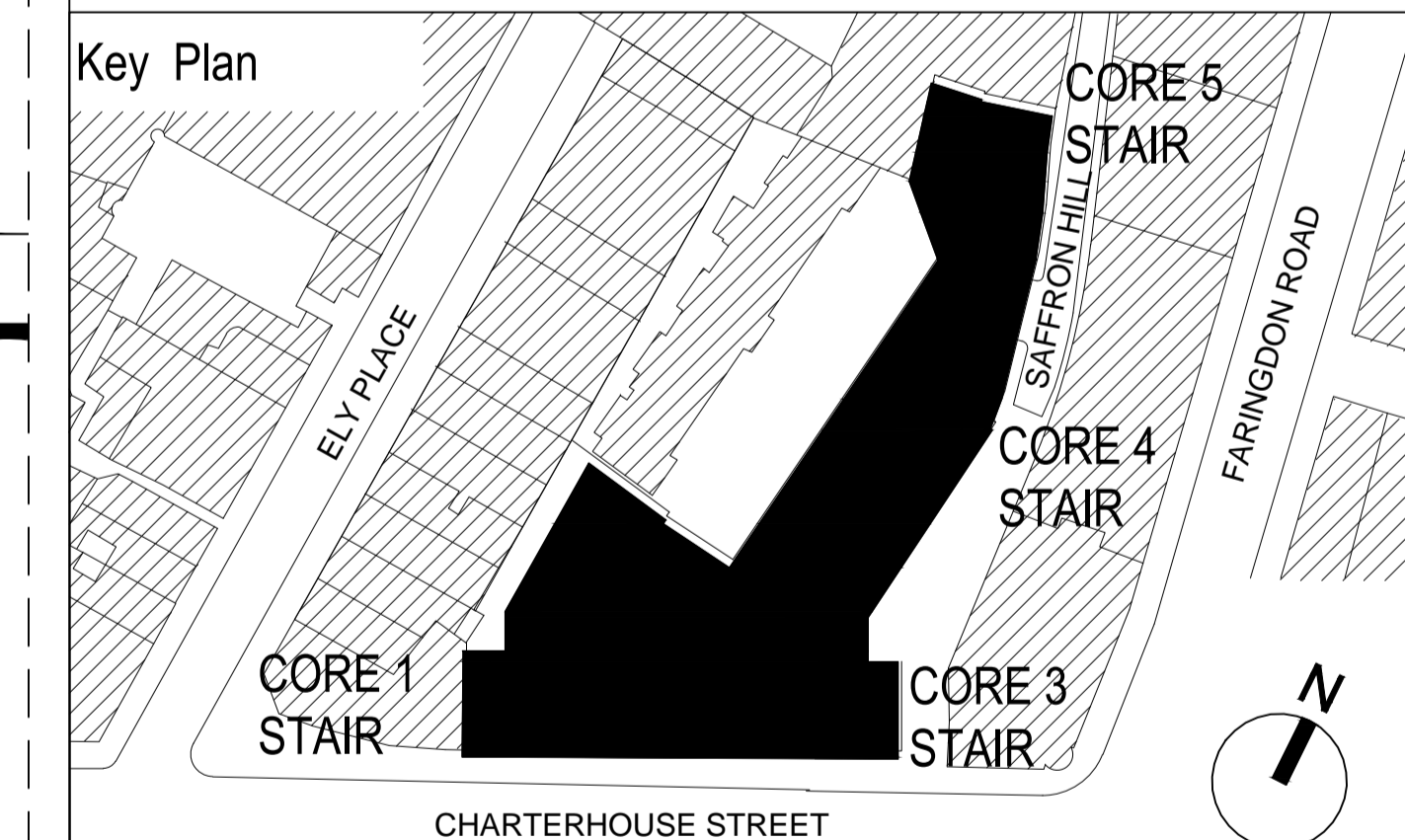
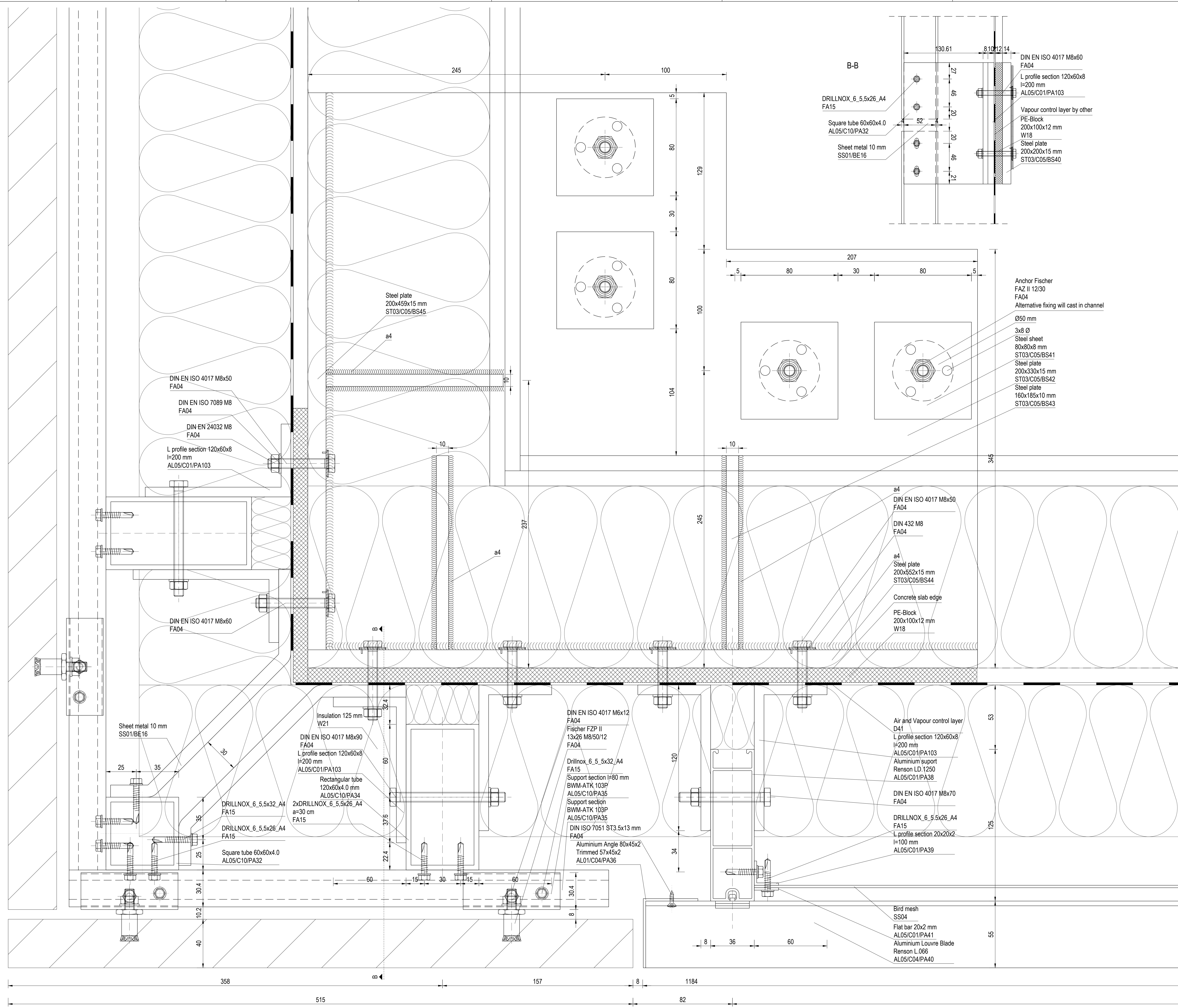

APPROVAL Status B
DATE: 16.12.2018

Rev	Revisions	Date	Drawn	Checked
C1	Approval Status B 16.12.2018; design adjusted	11-Jan-19	A. Figueroa	F. Schurig

SCHNEIDER **Schneider GB Ltd**
Downstream Offices
Butlers Wharf West
38 Shad Thames
London, SE1 2YD
t +44 (0) 20 7401 6383
www.schneider-facades.co.uk

WINDOWS
FACADES
CURTAIN WALLING

JOB NO.: K30152
CONTRACT: 17 Charterhouse Street
ARCHITECTS: MCM Architecture Limited
DRAWING TITLE: Main Work
EWS-05
Horizontal section

Scale: A3, 1:1
Date: 19-NOV-18
Checked-by: F.Schurig
Drawn by: A. Figueroa
Revision: C1

This drawing is our property. Each duplication, utilization or passing on to third persons is forbidden and will be pursued.

Doc. Reference: SGB-Sample SAM-014

Doc. Title: Range sample anodized profil

Schneider (GB) Ltd. Downstream Offices Butlers Wharf West 38 Shad Thames London, SE1 2YD		SCHNEIDER	
SGB Sample No.	SAM-014		
Uploaded	---		
Submission Date	12/10/2018		
Submitted to	Wates		
Description	Range sample		
Spec. Section	AKT II Z33		
Material/Surface	Alu profil EN AW6060 T66 / E6 C33 dark		
Revision	00		
Installation Site	Each EWS type		
	A	APPROVED	Fabrication/installation may be undertaken.
	B	APPROVED AS NOTED	
	C	REVISE AND RESUBMIT	Fabrication/installation MAY NOT be undertaken. In resubmitting, limit corrections to items marked.
	D	REJECTED	
Comments: -			
	APPROVED BY	DATE	SIGNATURE
Architect			
Client			
COUNTERSIGNED:			
BY:		DATE:	
FILE NO.		SUBMITTAL NO.	
P2020-SGB-SAM-014			

Pictures:



Downstream Offices Butlers Wharf West 38 Shad Thames London, SE1 2YD Sample Approval		SCHNEIDER	
SGB Job No.	K 30152		
SGB Job	P2020		
SGB Sample No.	SAM-14		
Spec. Section	AKT II Z33		
Description	Range sample Anodized profil		
Material/Surface	E6 C33 dark		
Issue Date	12.10.18		
	A	APPROVED	Fabrication/installation may be undertaken.
	B	APPROVED AS NOTED	
	C	REVISE AND RESUBMIT	Fabrication/installation MAY NOT be undertaken. In resubmitting, limit corrections to items marked.
	D	REJECTED	
Comments: see sample sheet			
	APPROVED BY	DATE	SIGNATURE
Architect			
COUNTERSIGNED:			
BY:		DATE:	
FILE NO.		SUBMITTAL NO.	

MCM