

LEGEND

GRANT ASSOCIATES LANDSCAPING LAYOUT LINEWORK

NOTES:

1. LANDSCAPING LAYOUT TAKEN FROM GRANT ASSOCIATES DRAWING NO. AGC377-AL-SK-101_LANDSCAPE LAYOUT 20171108
2. ALL VEHICLE TRACKING UNDERTAKEN AT 5MPH
3. VEHICLE WAS TURNED ON THE SPOT FOR TIGHTER TURNING IN SOME INSTANCES
4. REFUSE TRUCK VEHICLE IS 10.14m LONG x 2.50m WIDE. THE DESIGN VEHICLE SHOULD BE VALIDATED BY THE RELEVANT HIGHWAYS DEPARTMENT

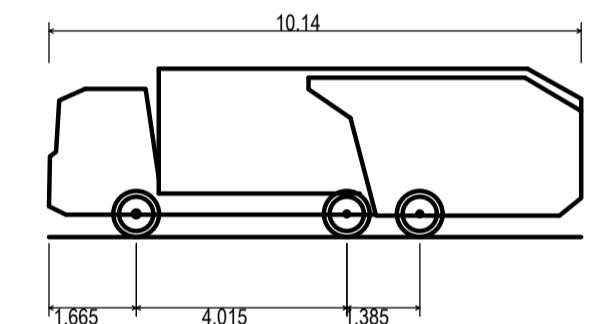

Phoenix 2 High Capacity Twin Pack 20 (with Elite 2 6x4 chassis)
 Overall Length 10.140m
 Overall Width 2.500m
 Overall Body Height 3.205m
 Min Body Ground Clearance 0.410m
 Track Width 2.500m
 Lock to lock time 4.00s
 Kerb to Kerb Turning Radius 9.100m

P3	SITE LAYOUT UPDATED & VEHICLE TRACKING UPDATED TO SUIT. SUPERSEDED RED LINE BOUNDARY OMITTED	19.02.18	JJF	IK	MW
P2	GENERAL REVISION	19.09.17	JJF	IK	MW
P1	DRAFT ISSUE	17.08.17	JJF	IK	MW
Mark	Revision	Date	Drawn	Chkd	Appd

SCALING NOTE: Do not scale from this drawing. If in doubt, ask.
 UTILITIES NOTE: The position of any existing public or private sewers, utility services, plant or apparatus shown on this drawing is believed to be correct, but no warranty to this is expressed or implied. Other such plant or apparatus may also be present but not shown. The Contractor is therefore advised to undertake his own investigation where the presence of any existing sewers, services, plant or apparatus may affect his operations.

Drawing Issue Status **PRELIMINARY**
AGAR GROVE ESTATE REGENERATION
REFUSE VEHICLE SWEEP PATHS
SHEET 2 OF 2

Client			
Architect		ARCHITYPE	
Date of 1st Issue	Designed	Drawn	JJF
18.08.17	-	-	-
A1 Scale	Checked	Approved	MW
1:250	IK	-	-
Drawing Number	Revision		P3
T14011-PBA-DR-C-1b-FGH-00-TR-035	-		-

Offices throughout the UK and Europe
 www.peterbrett.com
 © Peter Brett Associates LLP
 LONDON
 Tel: 020 7566 8600