

Internal Room Elevation

Scale: 1:10

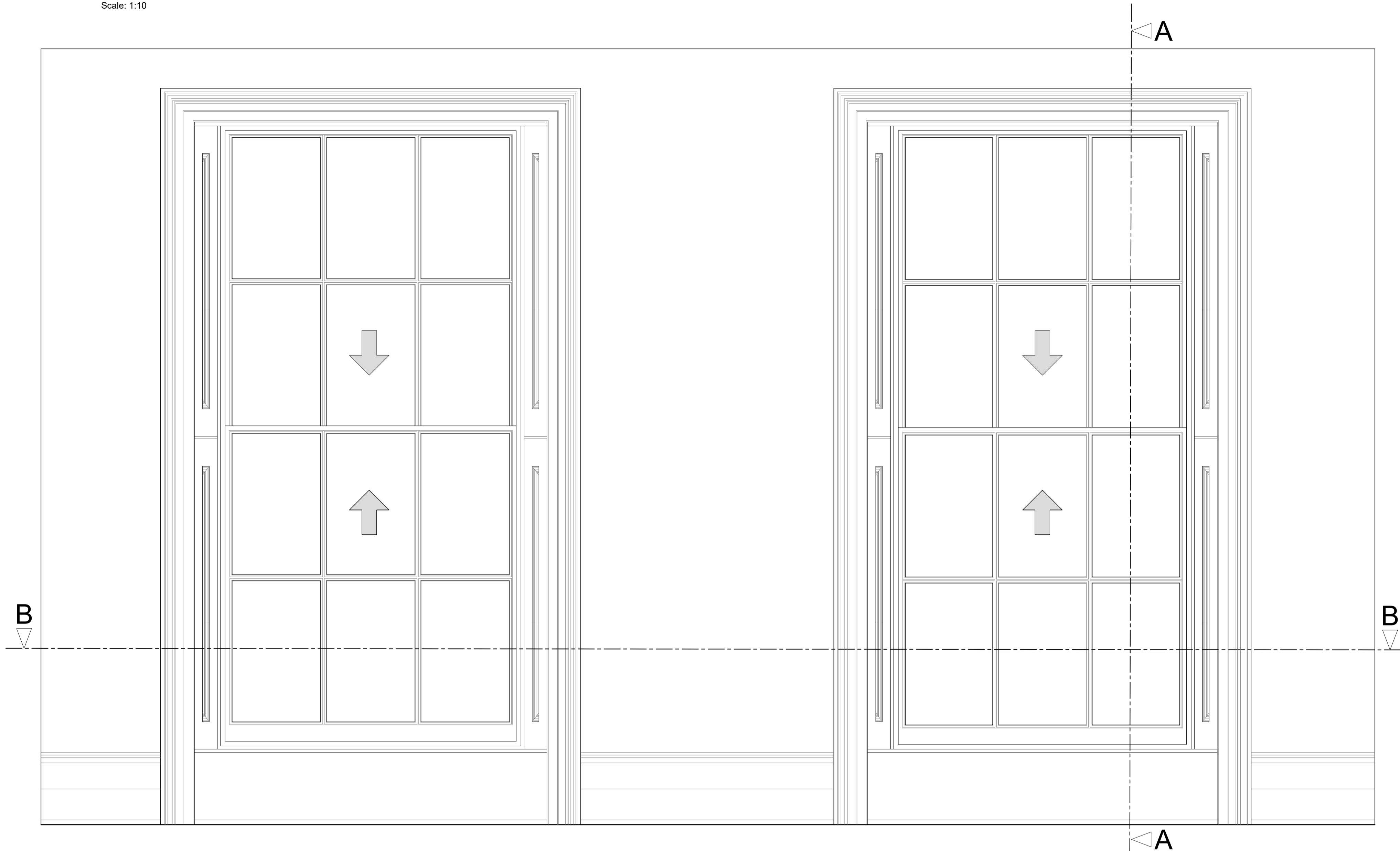

Section A-A through External Wall

Scale: 1:10

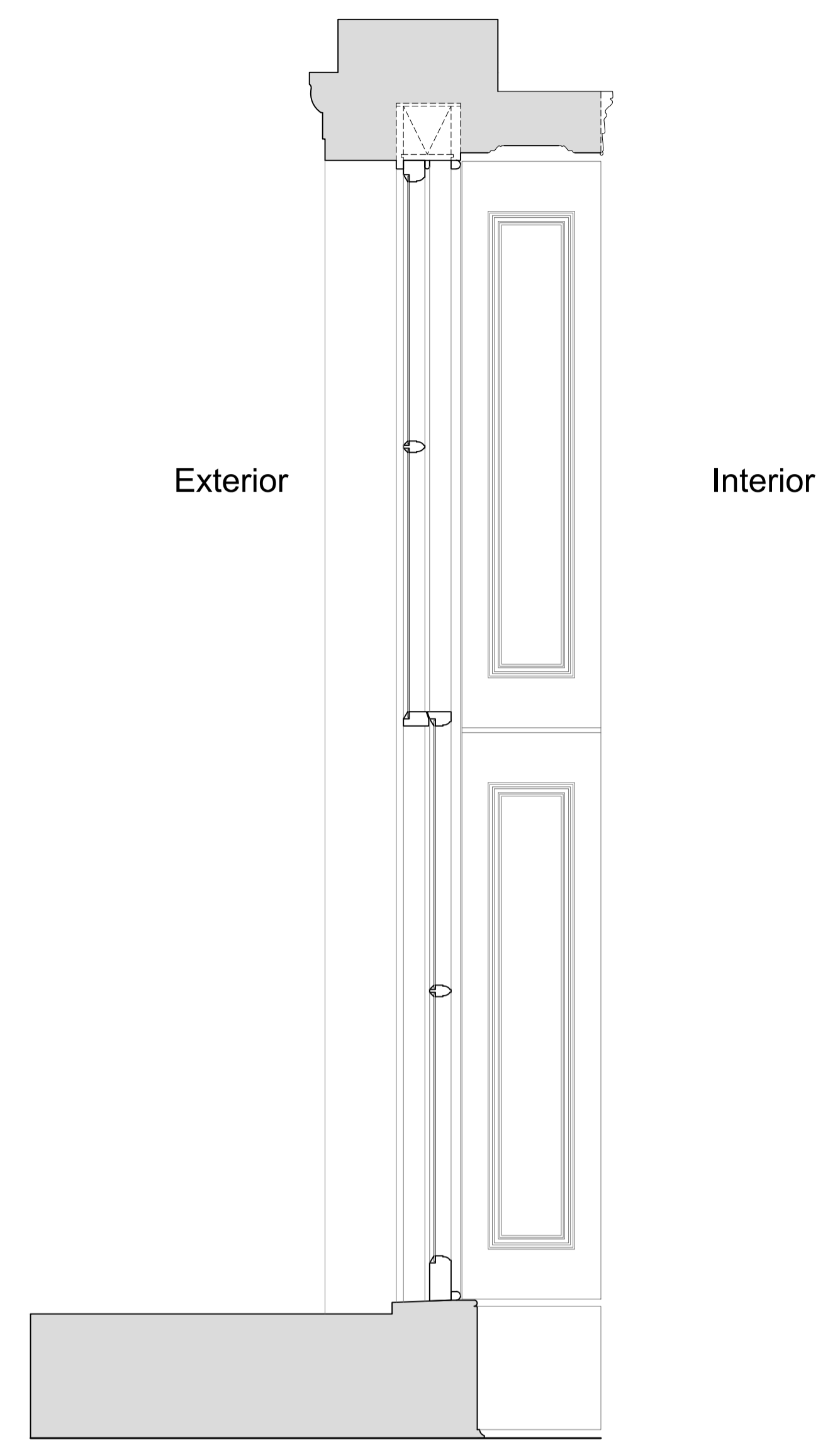

Plan Section B-B

Scale: 1:10

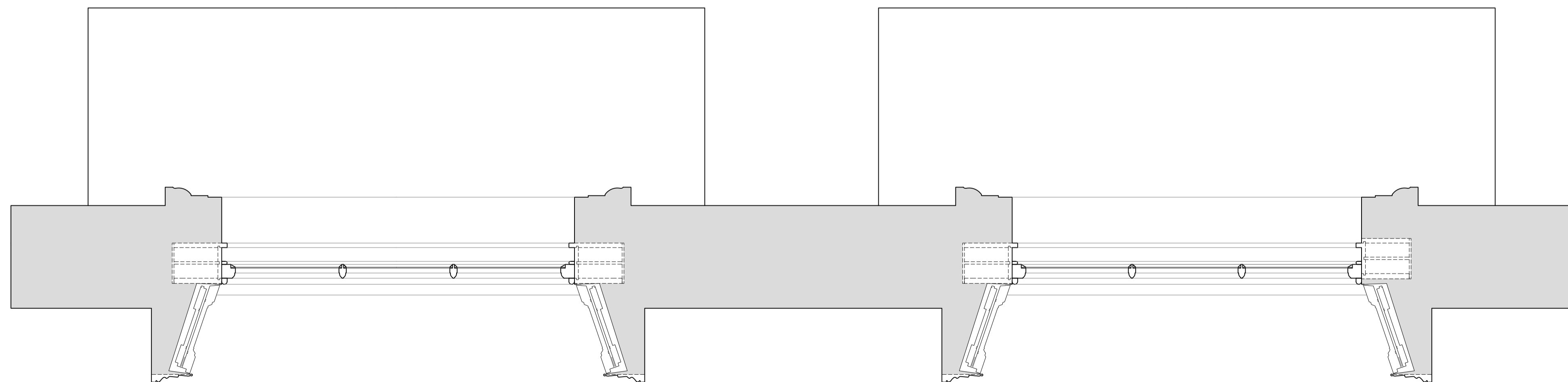

Revision	Date	Amendment
1.0	08-10-2018	Issued for listed building consent application

Do not reproduce this drawing without written permission  
All dimensions are in millimetres unless stated otherwise

Drawing Not For Construction

**HS2**

High Speed (HS2) Limited  
25th Floor  
One Canada Square  
Canary Wharf  
London E14 5AB

**COSTAIN SKANSKA**

Costain Skanska Joint Venture  
1st Floor  
The Podium  
1 Eversholt Street  
London NW1 2DN

Site Address: 54 B Delancey Street, London NW1			
Drawing Title: First Floor - Lounge: EXISTING Window Joinery Details - Sheet 1 of 3			
Drawn by: AP & PB	Checked by: AP	Checked by: VH	Presentation Scale: as shown @ A1
Date: 27-09-2018	Drawing No: WPI P066 NI - 54B DeS-EX-FF-J-01	Revision: 1.0	

Internal Room Elevation with Secondary Glazing Installed

Scale: 1:10

Slot ventilator providing 5000mm<sup>2</sup> of equivalent area background ventilation

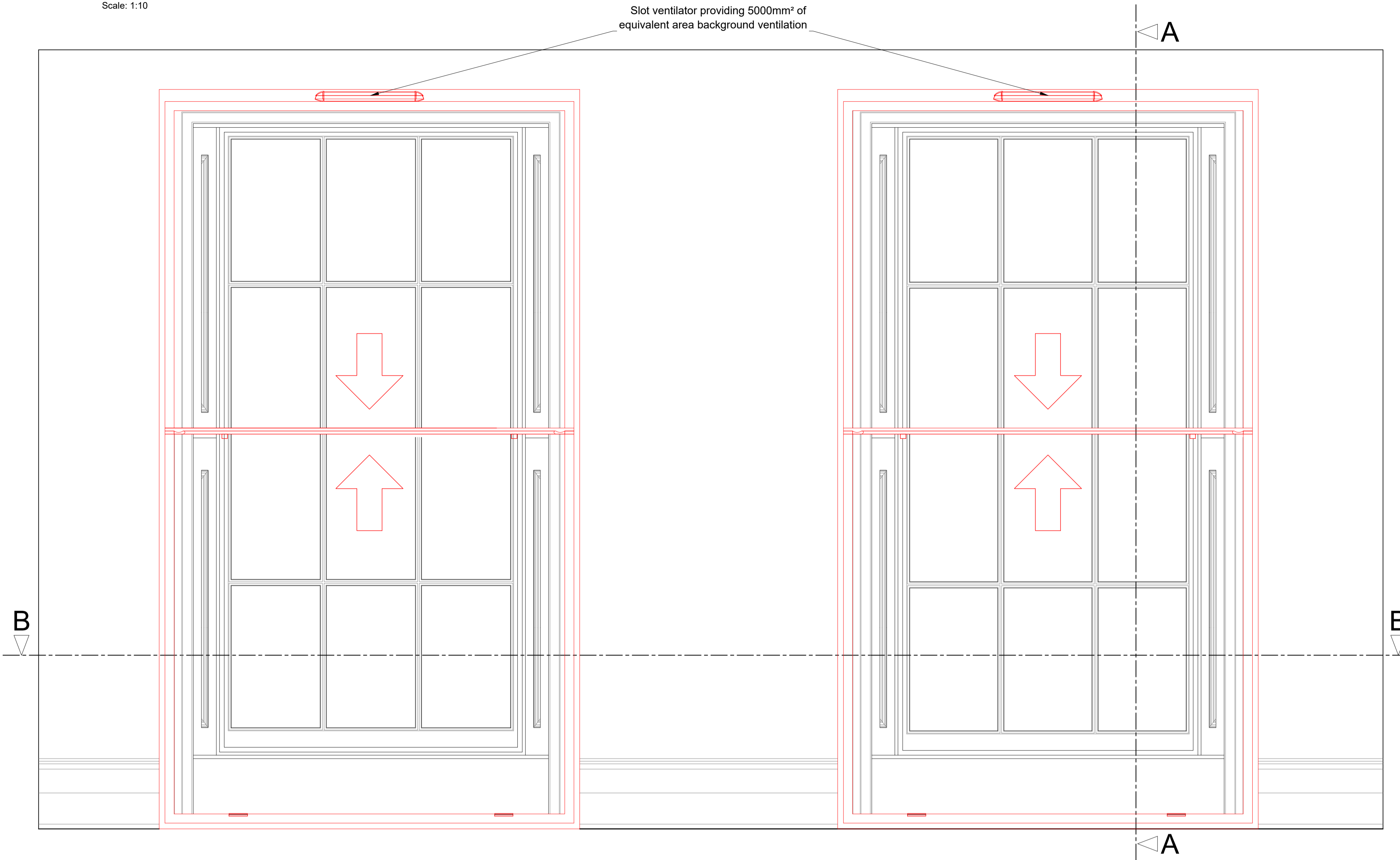

Section A-A through External Wall with Secondary Glazing Installed

Scale: 1:10

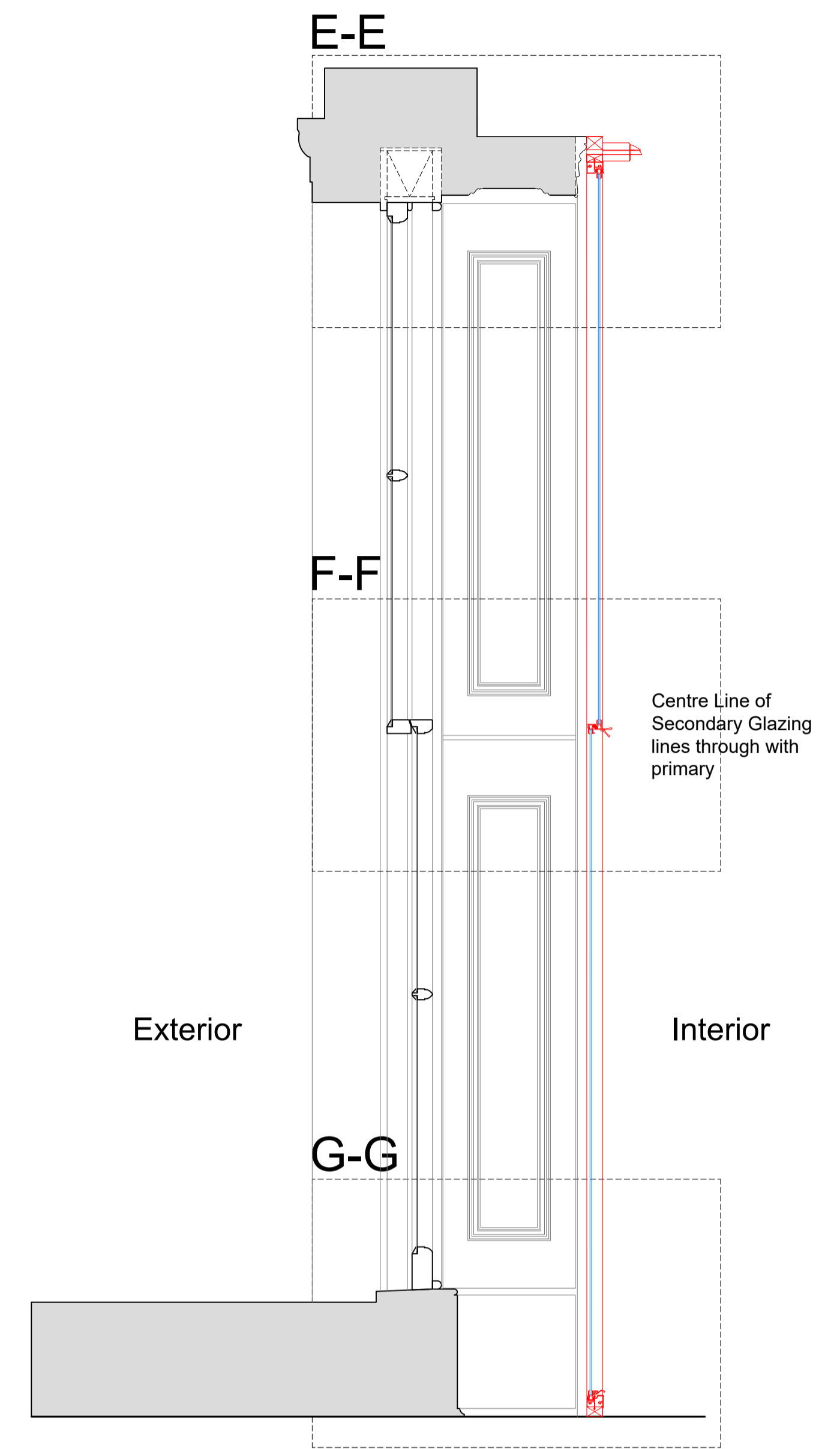

Plan Section B-B with Secondary Glazing Installed

Scale: 1:10

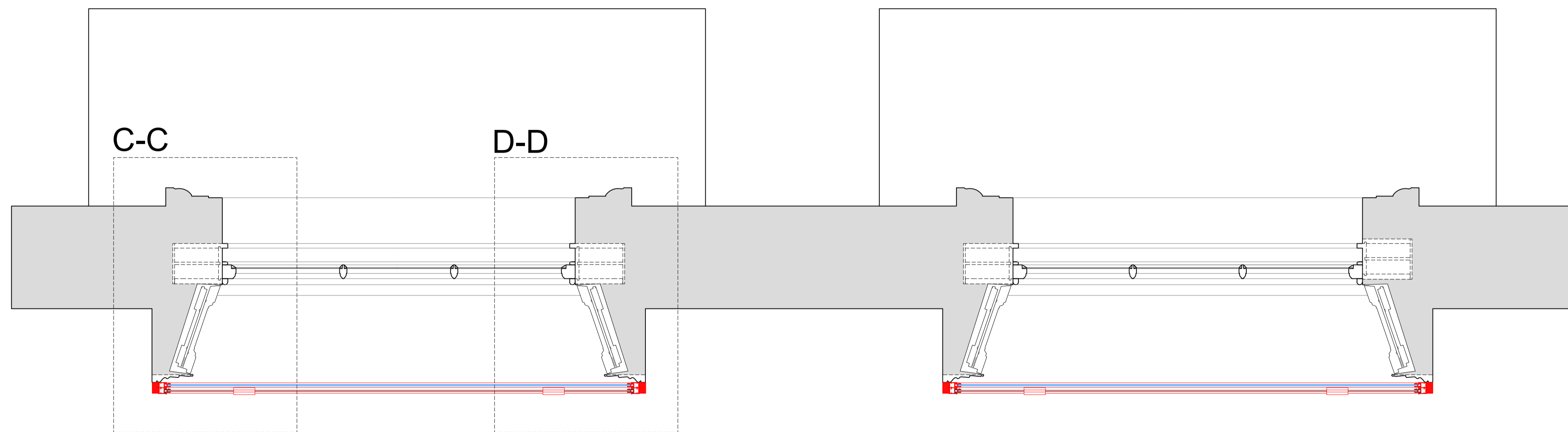

SECONDARY GLAZING SHOWN IN RED FOR VISUAL CLARITY ONLY

Revision	Date	Amendment
1.0	08-10-2018	Issued for listed building consent application

Do not reproduce this drawing without written permission  
All dimensions are in millimetres unless stated otherwise

Drawing Not For Construction

**HS2**

High Speed (HS2) Limited  
25th Floor  
One Canada Square  
Canary Wharf  
London E14 5AB

**COSTAIN SKANSKA**

Costain Skanska Joint Venture  
1st Floor  
The Podium  
1 Eversholt Street  
London NW1 2DN

Site Address:  
54 B Delancey Street, London NW1

Drawing Title:  
First Floor - Lounge: PROPOSED Secondary Glazing Details -  
Sheet 2 of 3

Drawn by: AP & PB      Checked by: AP      Presentation Scale: as shown @ A1

Date: 27-09-2018      Drawing No: WPI P066 NI - 54B DeS-PR-FF-J-01.1      Revision: 1.0

**Section C-C**  
Scale: 1:5 on A1

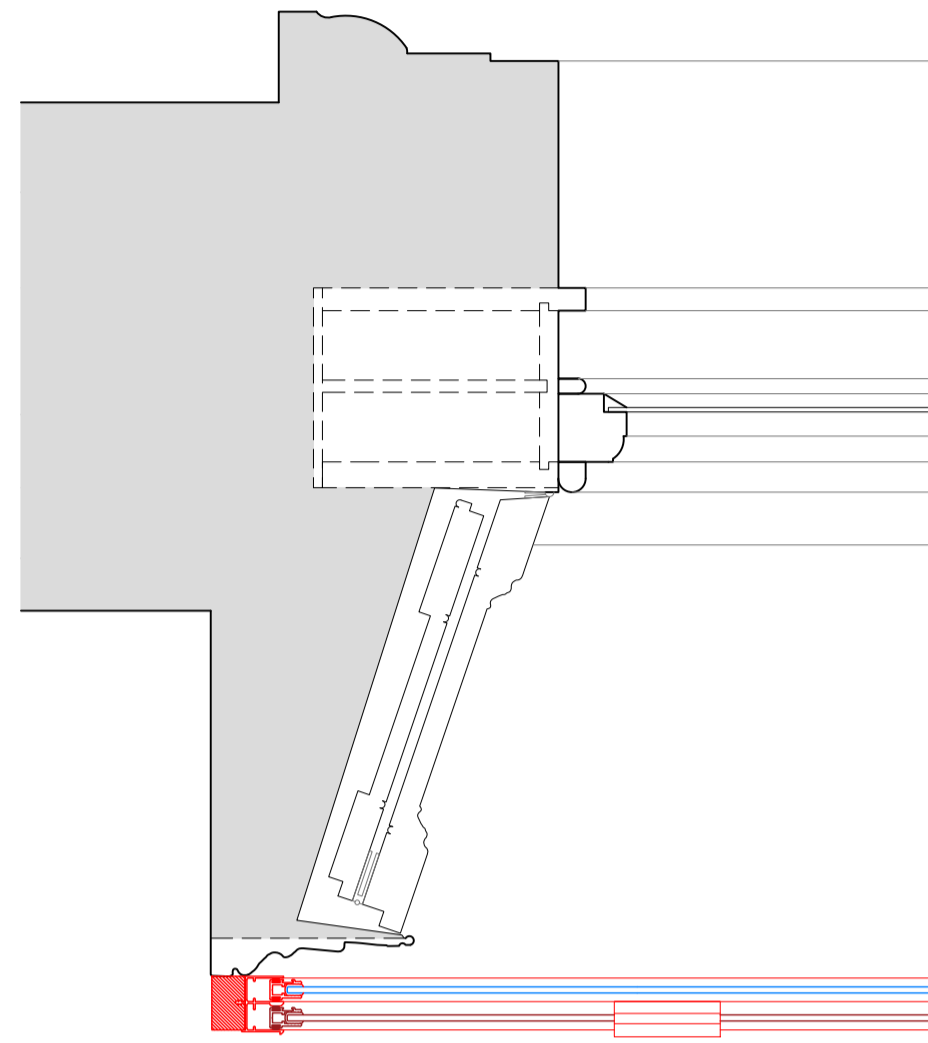

**Section E-E**  
Scale: 1:5 on A1

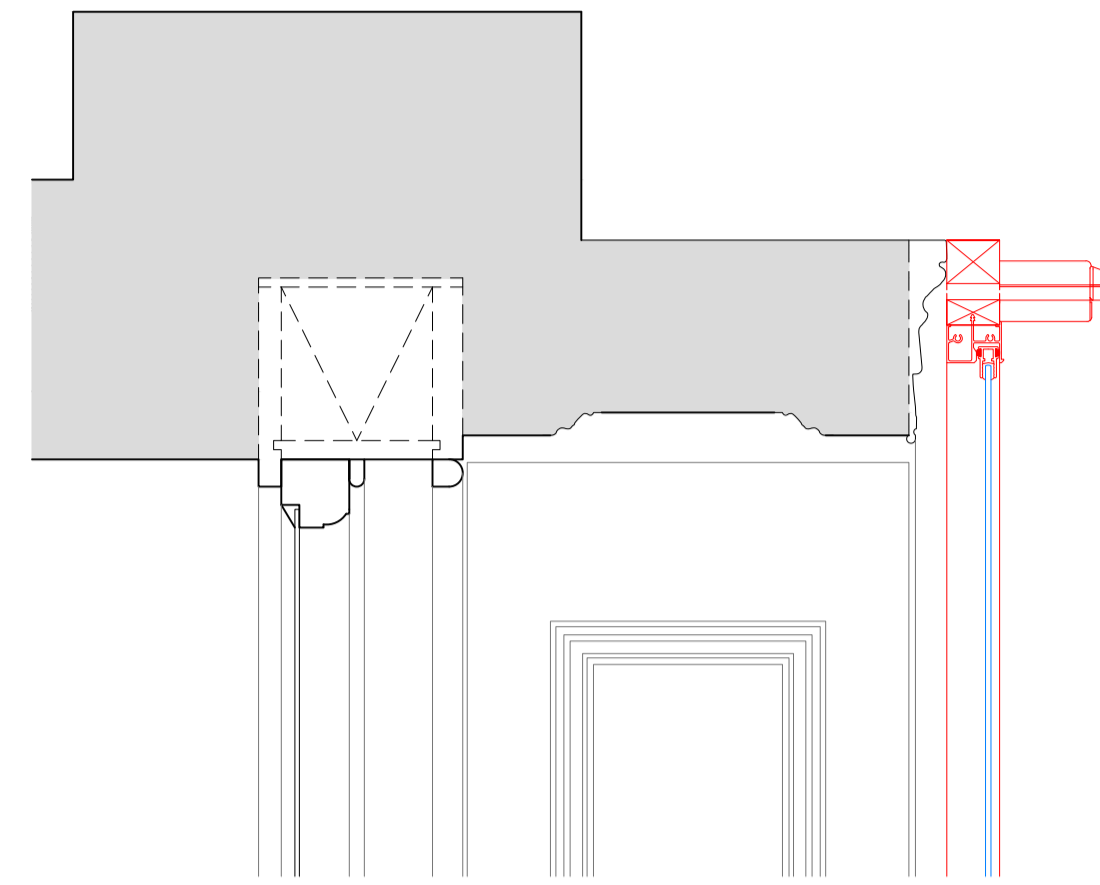

**Section F-F**  
Scale: 1:5 on A1

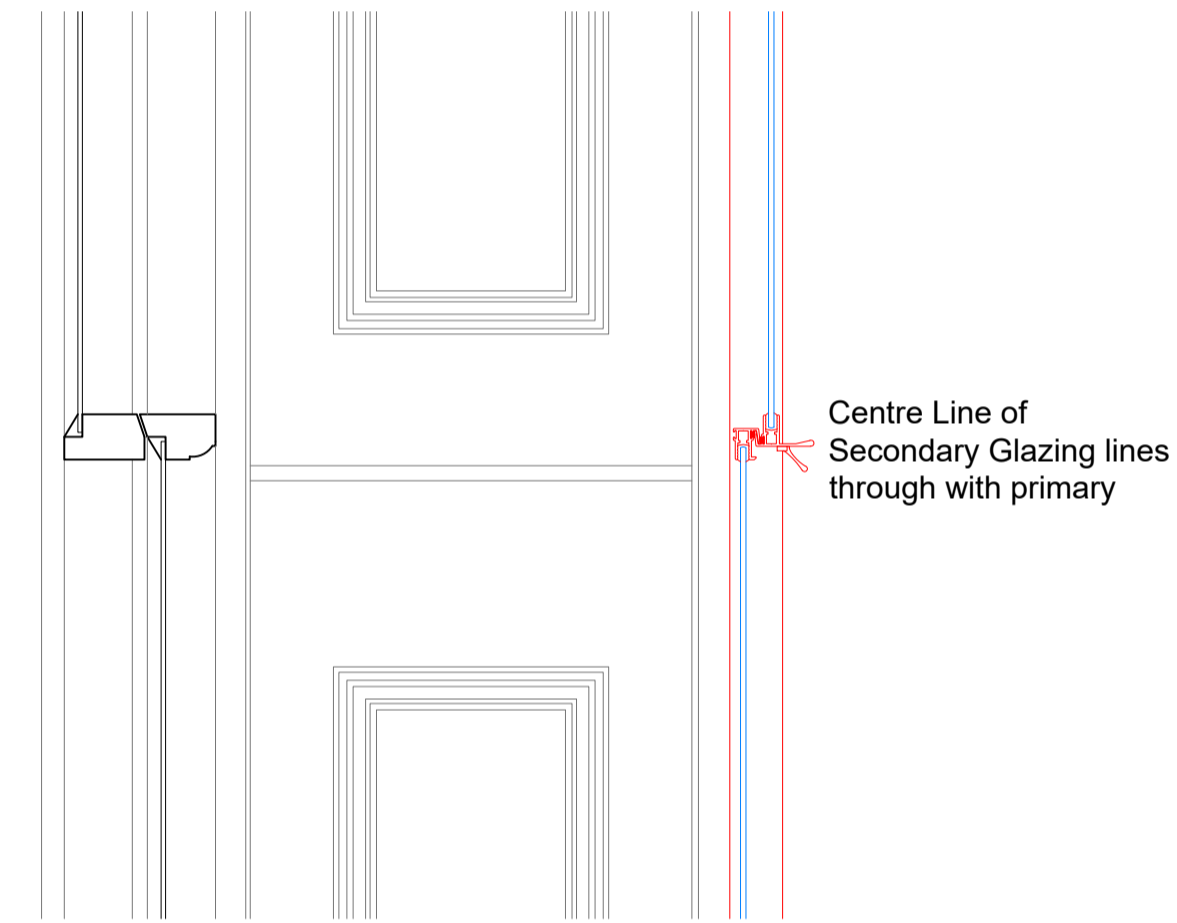

**Section D-D**  
Scale: 1:5 on A1

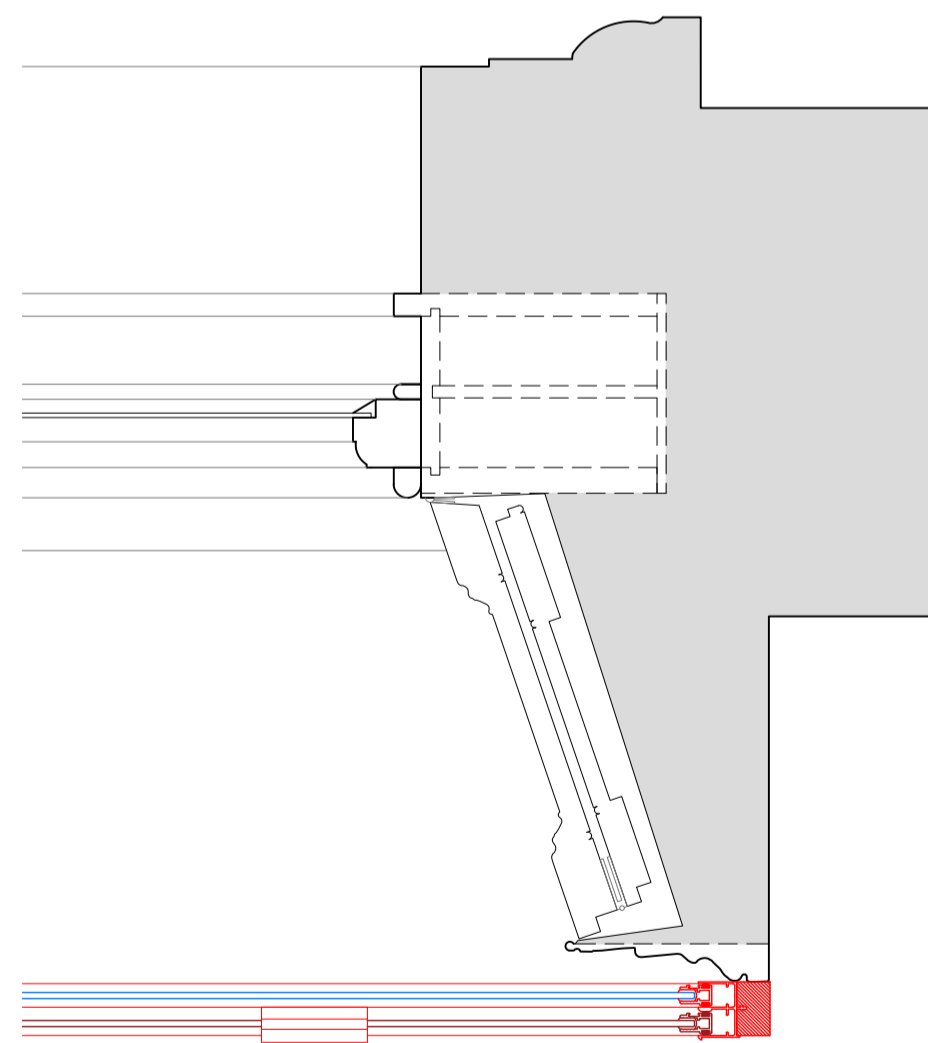

**Section G-G**  
Scale: 1:5 on A1

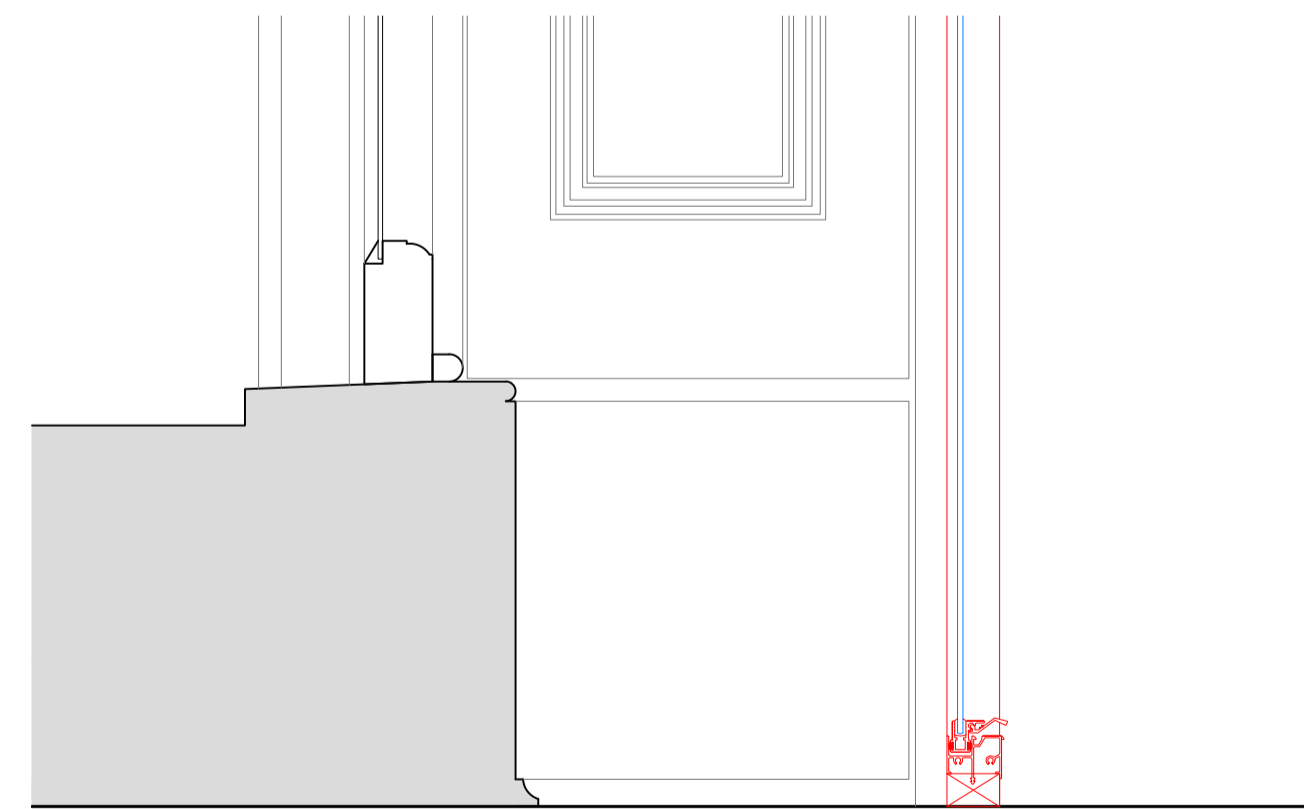

SECONDARY GLAZING SHOWN IN RED FOR VISUAL CLARITY ONLY

Revision	Date	Assessment
1.0	08-10-2018	Issued for listed building consent application

Do not reproduce this drawing without written permission  
All dimensions are in millimetres unless stated otherwise

Drawing Not For Construction

**HS2**

High Speed (HS2) Limited  
25th Floor  
One Canada Square  
Canary Wharf  
London E14 5AB

**COSTAIN SKANSKA**

Costain Skanska Joint Venture  
1st Floor  
The Podium  
1 Eversholt Street  
London NW1 2DN

Site Address: 54 B Delancey Street, London NW1			
Drawing Title: First Floor - Lounge: PROPOSED Secondary Glazing Details - Sheet 3 of 3			
Drawn by: AP & PB	Drawn by: AP	Checked by: VH	Presentation Scale: 1:5 @ A1
Date: 27-09-2018	Drawing No: WPI P066 NI - 54B DeS-PR-FF-J-01.2	Revision: 1.0	