

TPS.

TAYLOR PROJECT SERVICES LLP
BUILDING SERVICES CONSULTANTS



THE BEDFORD ESTATES

TPS.LLP 13 Bedford Square, London, WC1B 3JA

Planning Issue Drawings – VRV Scheme – February 2019

THIS DRAWING MUST NOT BE REPRODUCED WITHOUT PRIOR CONSENT.
DO NOT SCALE FROM THIS DRAWING.
THIS DRAWING IS COPYRIGHTED

GENERAL NOTES

B E D F O R D
S Q U A R E

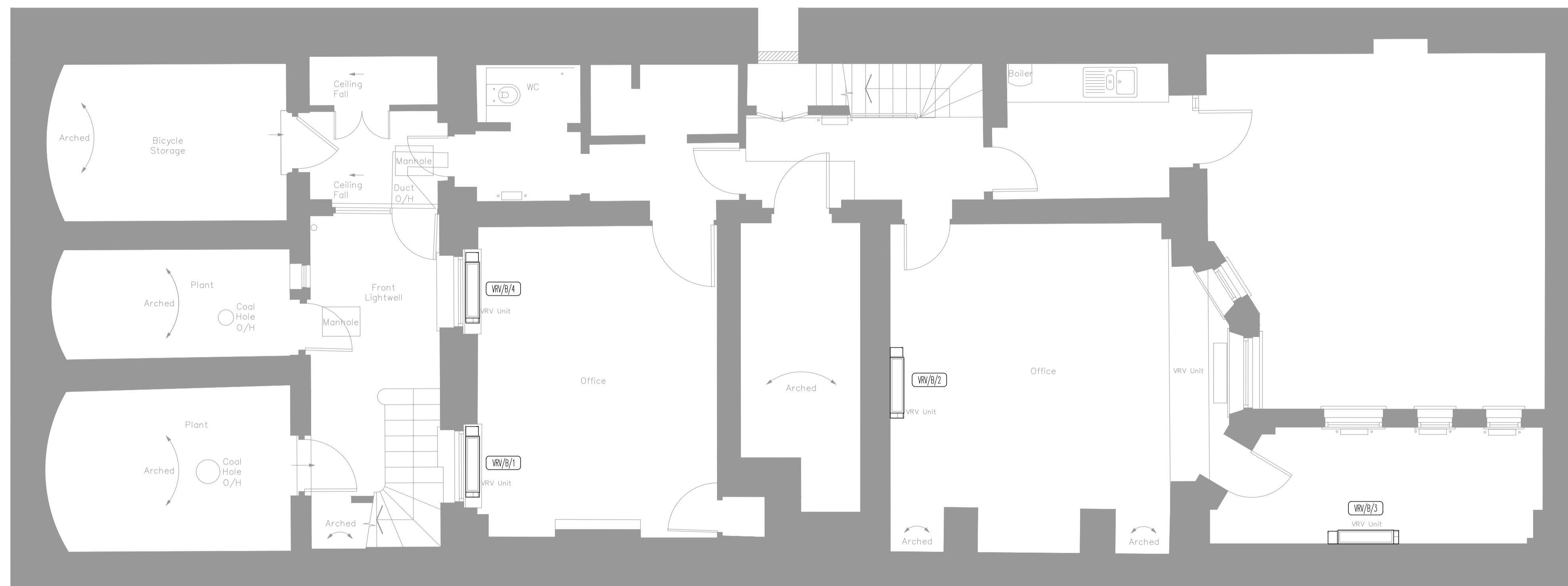

PLANNING

0	FEB.19	PLANNING ISSUE
Rev	Date	Description

TPS.
Taylor Project Services LLP
No.1 Cornhill
London EC3V 9ND
Tel 020 7743 6602
www.taylorprojectservices.com

Client
 **THE BEDFORD ESTATES**
29a Montague Street
London
WC1B 5BL
Tel 0201 636 2988
Fax 0201 255 1729

Project
13 BEDFORD SQUARE
LONDON
WC1

Drawing Title
LOWER GROUND FLOOR
MECHANICAL SERVICES
LAYOUT

Scale 1:50 @ A1	Date AUG.18
Drawn L.T.	Checked G.N.T.

Drawing Status	PLANNING
Revision 0	

Drawing No. TPS/13BS/LG/M

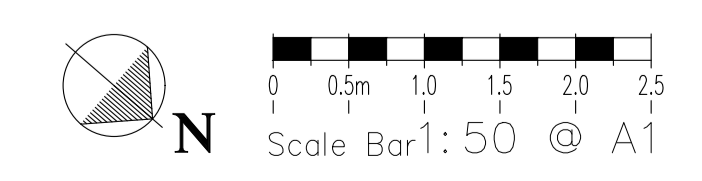

THIS DRAWING MUST NOT BE REPRODUCED WITHOUT PRIOR CONSENT.
DO NOT SCALE FROM THIS DRAWING.
THIS DRAWING IS COPYRIGHTED

GENERAL NOTES

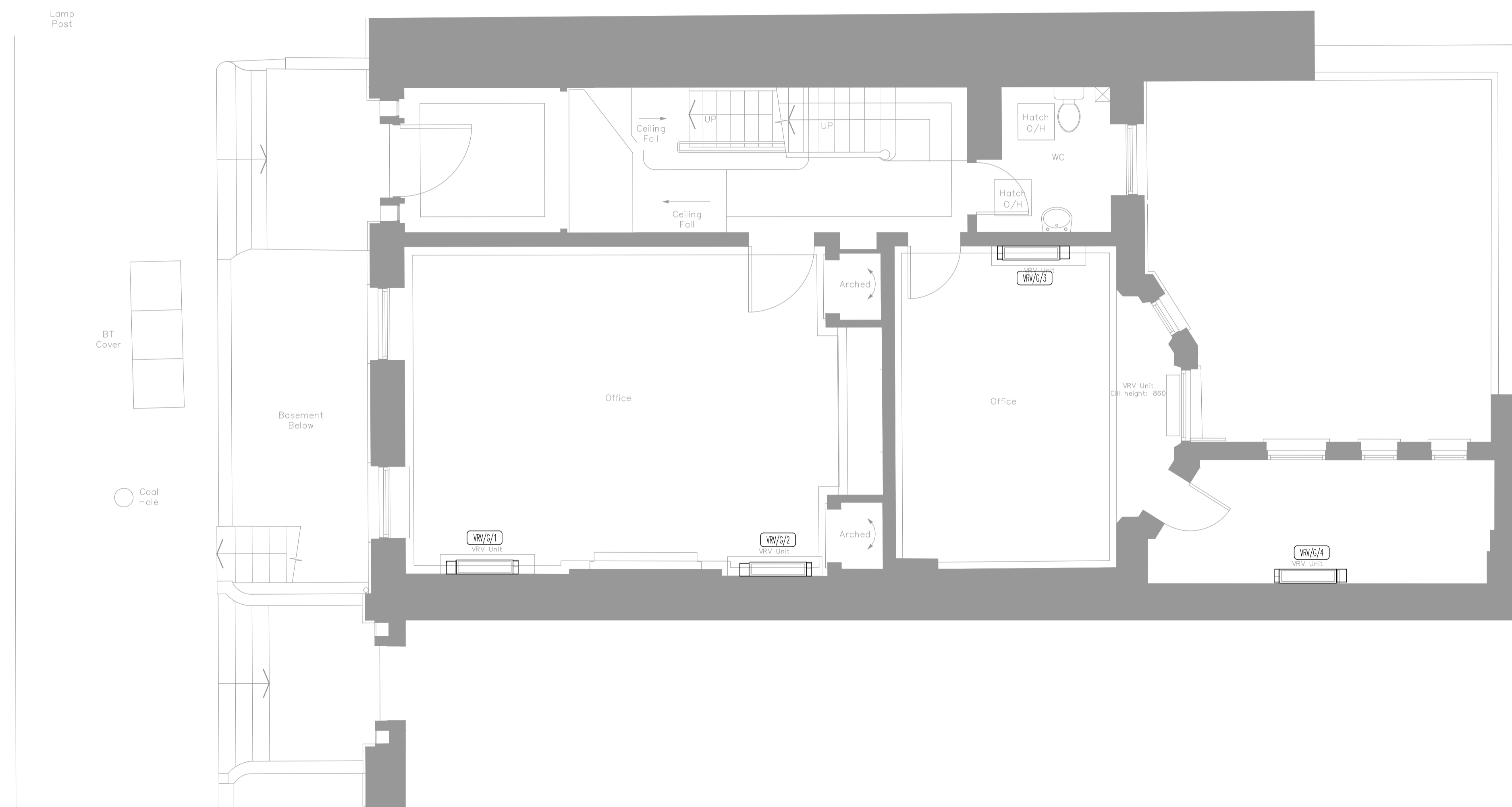

PLANNING

0	FEB.19	PLANNING ISSUE
Rev	Date	Description

TPS.
Taylor Project Services LLP
No.1 Cornhill
London EC3V 9ND
Tel 020 7743 6602
www.taylorprojectservices.com

Client

THE BEDFORD ESTATES
 29a Montague Street
 London
 WC1B 5BL
 Tel 0771 656 2988
 Fax 0771 255 1729

Project
 13 BEDFORD SQUARE
 LONDON
 WC1

Drawing Title
 GROUND FLOOR
 MECHANICAL SERVICES
 LAYOUT

Scale 1:50 @ A1	Date AUG.18
Drawn L.T.	Checked G.N.T.

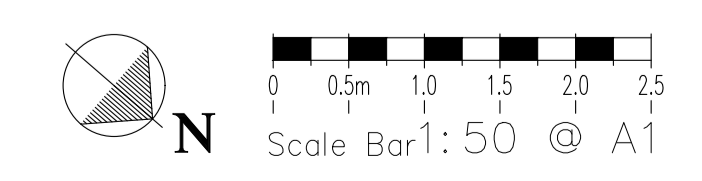
Drawing Status	PLANNING
Revision	0
Drawing No.	TPS/13BS/G/M



THIS DRAWING MUST NOT BE REPRODUCED WITHOUT PRIOR CONSENT.
DO NOT SCALE FROM THIS DRAWING.
THIS DRAWING IS COPYRIGHTED

GENERAL NOTES

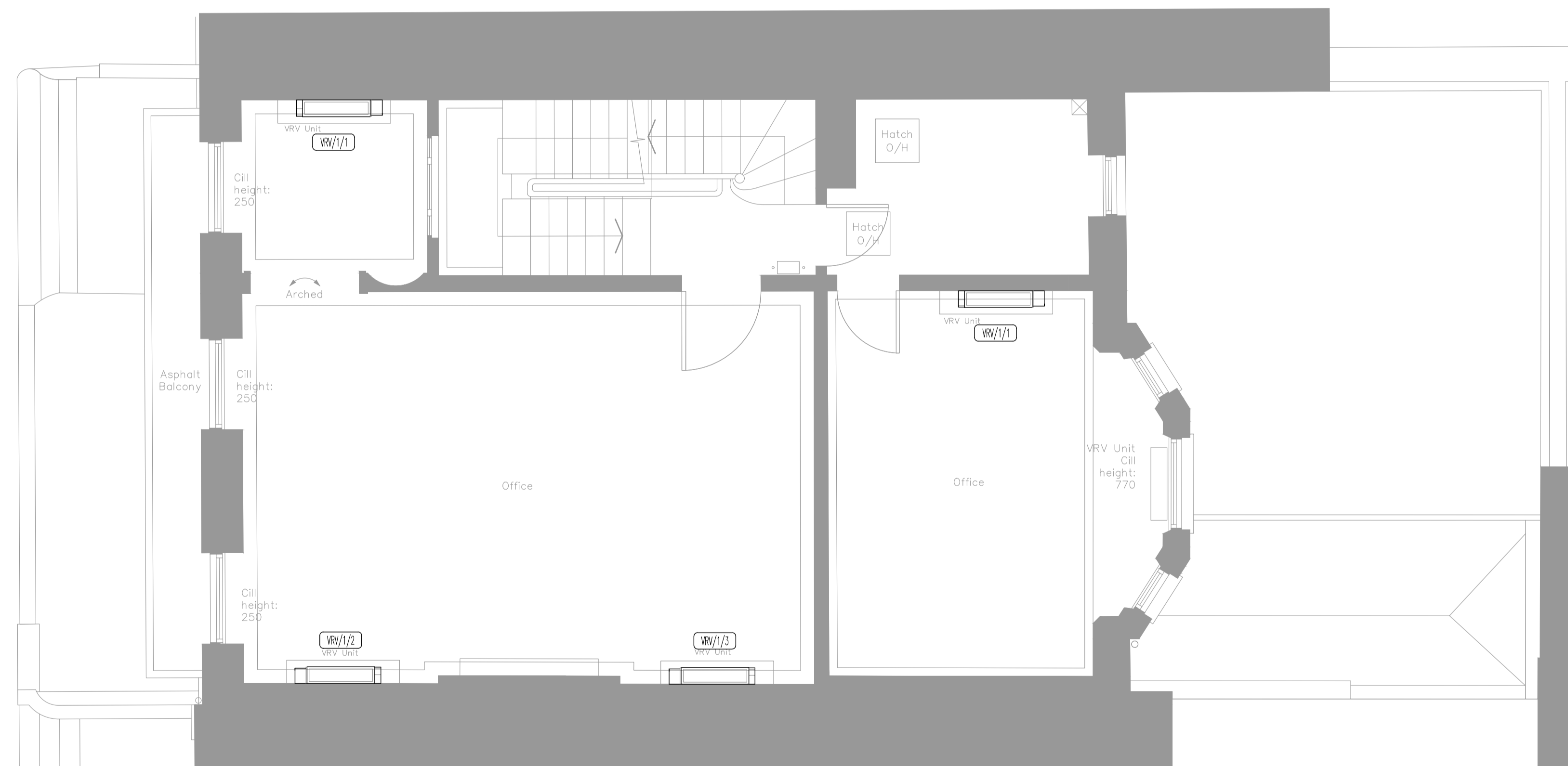

PLANNING

0	FEB.19	PLANNING ISSUE
Rev	Date	Description

TPS.
Taylor Project Services LLP
No.1 Cornhill
London EC3V 9ND
Tel 020 7743 6602
www.taylorprojectservices.com

Client

THE BEDFORD ESTATES
 29a Montague Street
 London
 WC1B 5BL
 Tel: 0201 636 2980
 Fax: 0201 251 1229

Project
 13 BEDFORD SQUARE
 LONDON
 WC1

Drawing Title
 FIRST FLOOR
 MECHANICAL SERVICES
 LAYOUT

Scale 1:50 @ A1	Date AUG.18
Drawn L.T.	Checked G.N.T.

Drawing Status
 PLANNING

Revision	0																		
----------	---	--	--	--	--	--	--	--	--	--	--	--	--	--	--	--	--	--	--

Drawing No. TPS/13BS/1/M

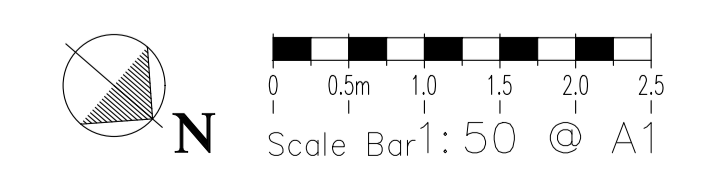

THIS DRAWING MUST NOT BE REPRODUCED WITHOUT PRIOR CONSENT.
DO NOT SCALE FROM THIS DRAWING.
THIS DRAWING IS COPYRIGHTED

GENERAL NOTES

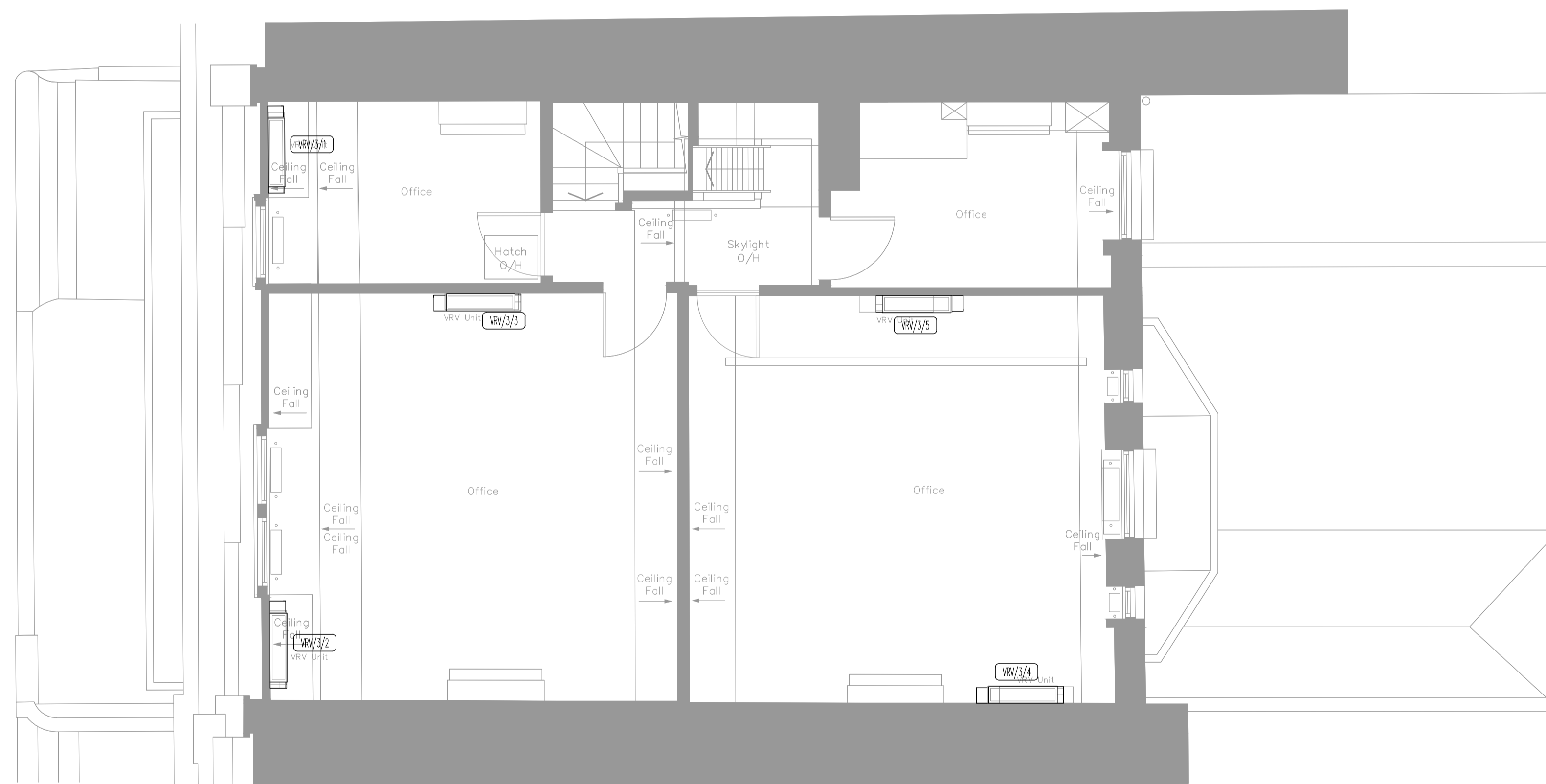

PLANNING

0	FEB.19	PLANNING ISSUE
Rev	Date	Description

TPS.
Taylor Project Services LLP

No.1 Cornhill
London EC3V 3ND
Tel 020 7743 6602
www.taylorprojectservices.com

Client



THE BEDFORD ESTATES
29a Montague Street
London
WC1B 5BL
Tel 020 7463 2888
Fax 020 7463 2929

Project
13 BEDFORD SQUARE
LONDON
WC1

Drawing Title
THIRD FLOOR
MECHANICAL SERVICES
LAYOUT

Scale 1:50 @ A1	Date AUG.18
Drawn L.T.	Checked G.N.T.

Drawing Status
PLANNING

Revision	0																		
----------	---	--	--	--	--	--	--	--	--	--	--	--	--	--	--	--	--	--	--

Drawing No. TPS/13BS/3/M

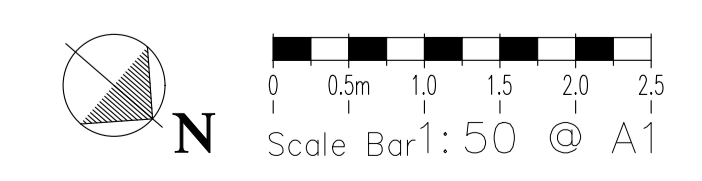

THIS DRAWING MUST NOT BE REPRODUCED WITHOUT PRIOR CONSENT.
DO NOT SCALE FROM THIS DRAWING.
THIS DRAWING IS COPYRIGHTED

GENERAL NOTES

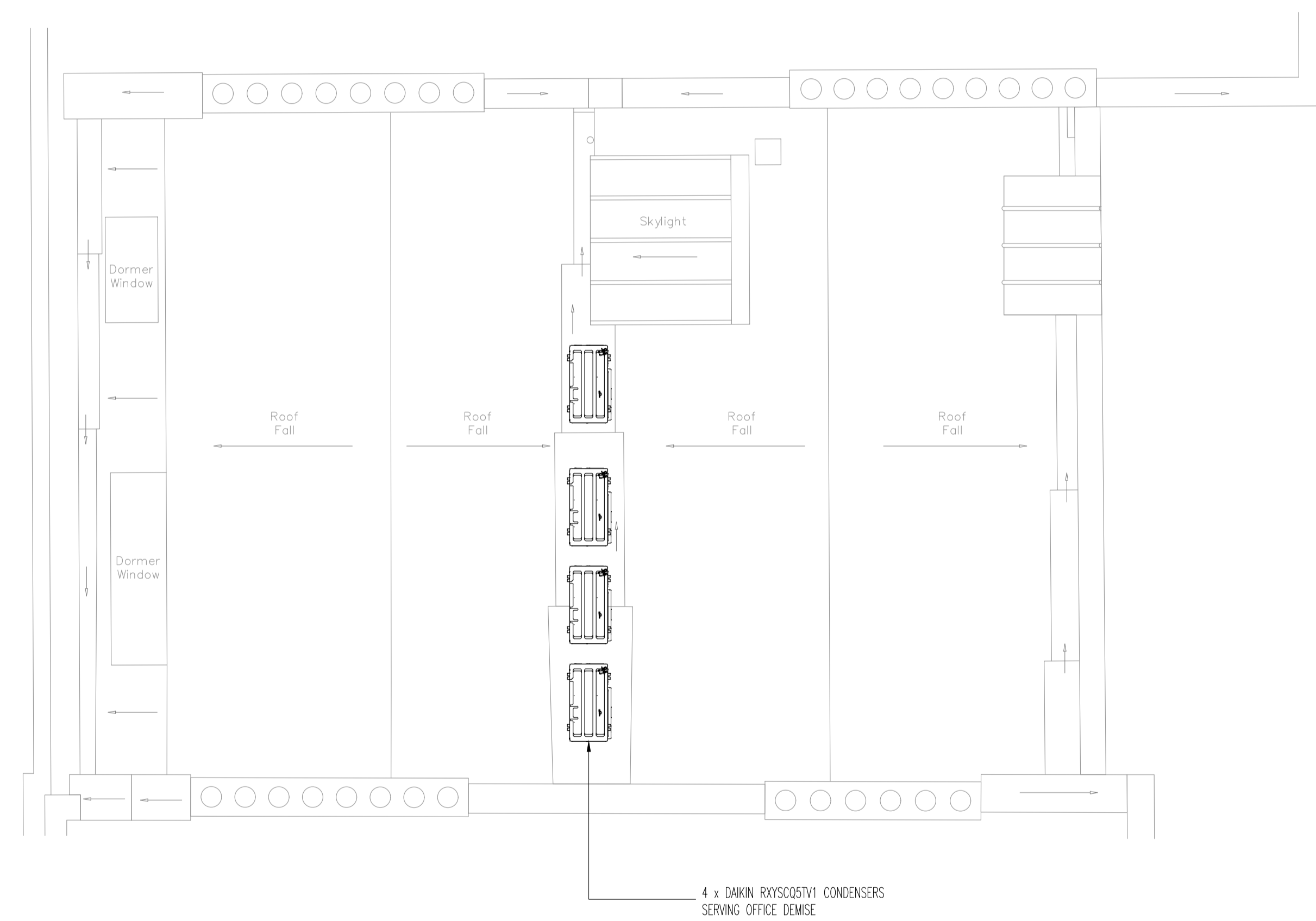

PLANNING

0	FEB.19	PLANNING ISSUE
Rev	Date	Description

TPS.
Taylor Project Services LLP
No.1 Cornhill
London EC3V 9ND
Tel 020 7743 6602
www.taylorprojectservices.com

Client
THE BEDFORD ESTATES
29a Montague Street
London
WC1B 5BL
Tel 0201 636 2988
Fax 0201 251 1729

Project
13 BEDFORD SQUARE
LONDON
WC1

Drawing Title
ROOF LEVEL
MECHANICAL SERVICES
LAYOUT

Scale 1:50 @ A1	Date AUG.18
Drawn L.T.	Checked G.N.T.

Drawing Status
PLANNING

Revision	0																		
----------	---	--	--	--	--	--	--	--	--	--	--	--	--	--	--	--	--	--	--

Drawing No. TPS/13BS/R/M

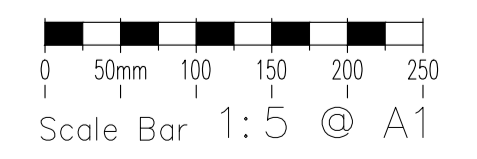

THIS DRAWING MUST NOT BE REPRODUCED WITHOUT PRIOR CONSENT.
DO NOT SCALE FROM THIS DRAWING.
THIS DRAWING IS COPYRIGHTED

GENERAL NOTES

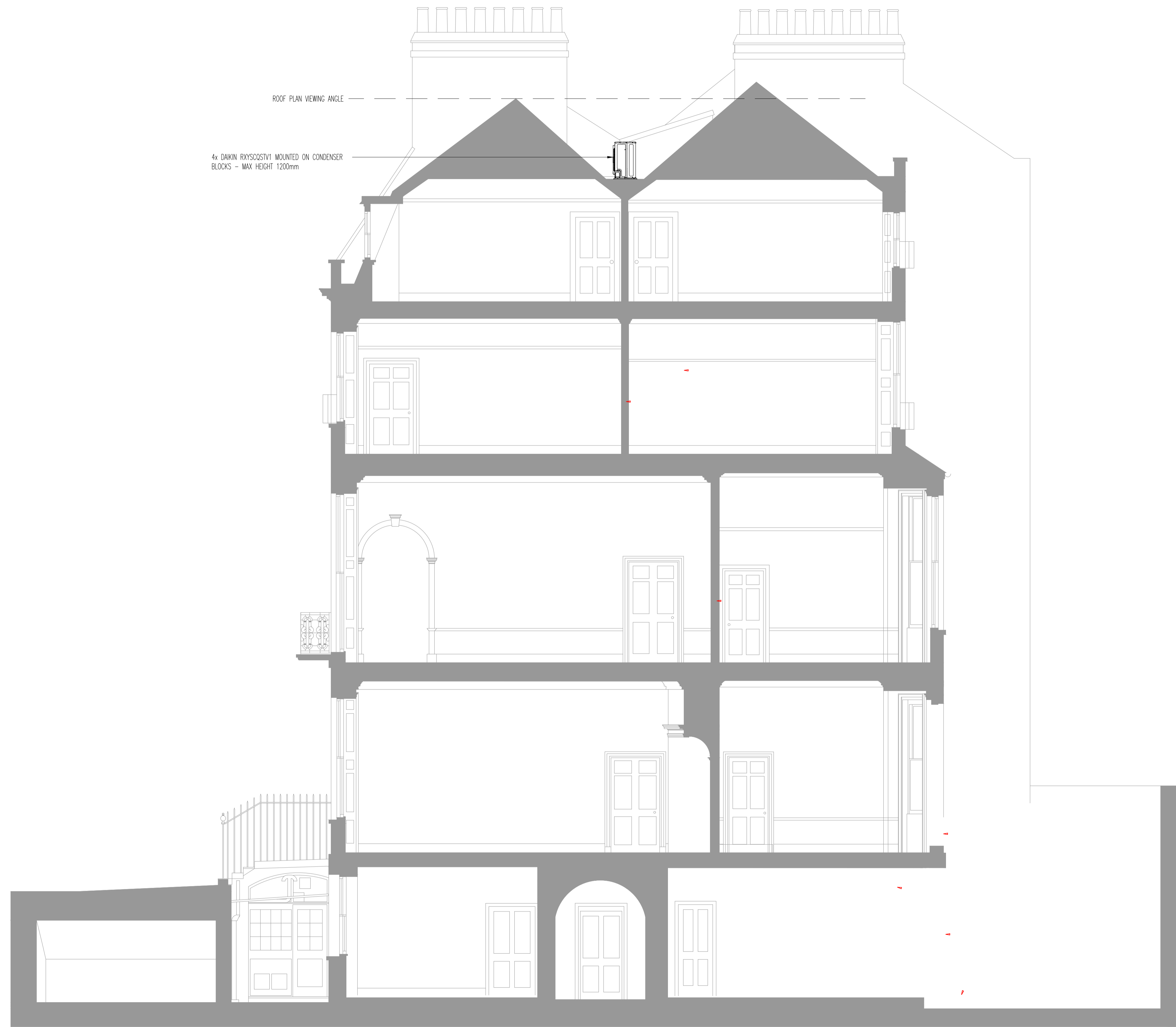

PLANNING

0	FEB.19	PLANNING ISSUE
Rev	Date	Description

TPS.

Taylor Project Services LLP

No.1 Cornhill
London EC3V 3ND
Tel 020 7743 6602
www.taylorprojectservices.com

Client



THE BEDFORD ESTATES
29a Montague Street
London
WC1B 5BL
Tel 020 7462 2868
Fax 020 7462 1229

Project
13 BEDFORD SQUARE
LONDON
WC1

Drawing Title
ROOF LEVEL
MECHANICAL SERVICES
LAYOUT

Scale 1:50 @ A1	Date AUG.18
Drawn L.T.	Checked G.N.T.

Drawing Status
PLANNING

Revision	0																		
----------	---	--	--	--	--	--	--	--	--	--	--	--	--	--	--	--	--	--	--

Drawing No. TPS/13BS/M/SEC



GENERAL NOTES

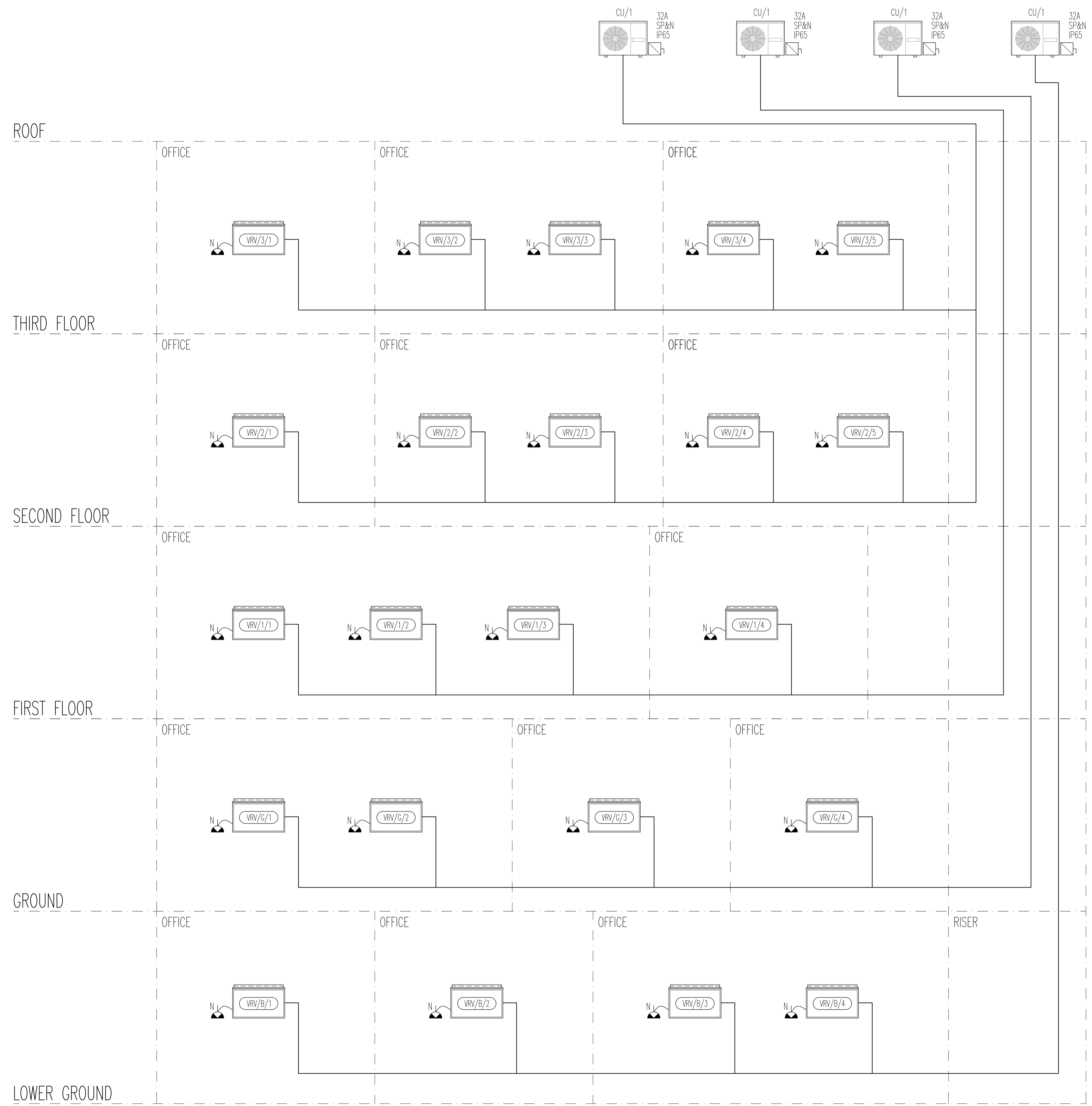

PLANNING

0	FEB.19	PLANNING ISSUE
Rev	Date	Description

TPS.
Taylor Project Services LLP
No.1 Cornhill
London, EC3V 3ND
Tel 020 7743 6602
www.taylorprojectservices.com

Client
THE BEDFORD ESTATES
29a Montague Street
London
WC1B 5SL
Tel: 0171 434 2865
Fax: 0171 255 1209

Project
13 BEDFORD SQ
LONDON
WC1

Drawing Title
VRV SCHEMATIC

Scale	N.T.S.	Date	AUG.18
Drawn	L.T.	Checked	G.N.T

Drawing Status
PLANNING

Revision	0								
----------	---	--	--	--	--	--	--	--	--

Drawing No.
TPS/13BS/VRVS

THIS DRAWING MUST NOT BE REPRODUCED WITHOUT PRIOR CONSENT.
DO NOT SCALE FROM THIS DRAWING.
THIS DRAWING IS COPYRIGHTED

GENERAL NOTES

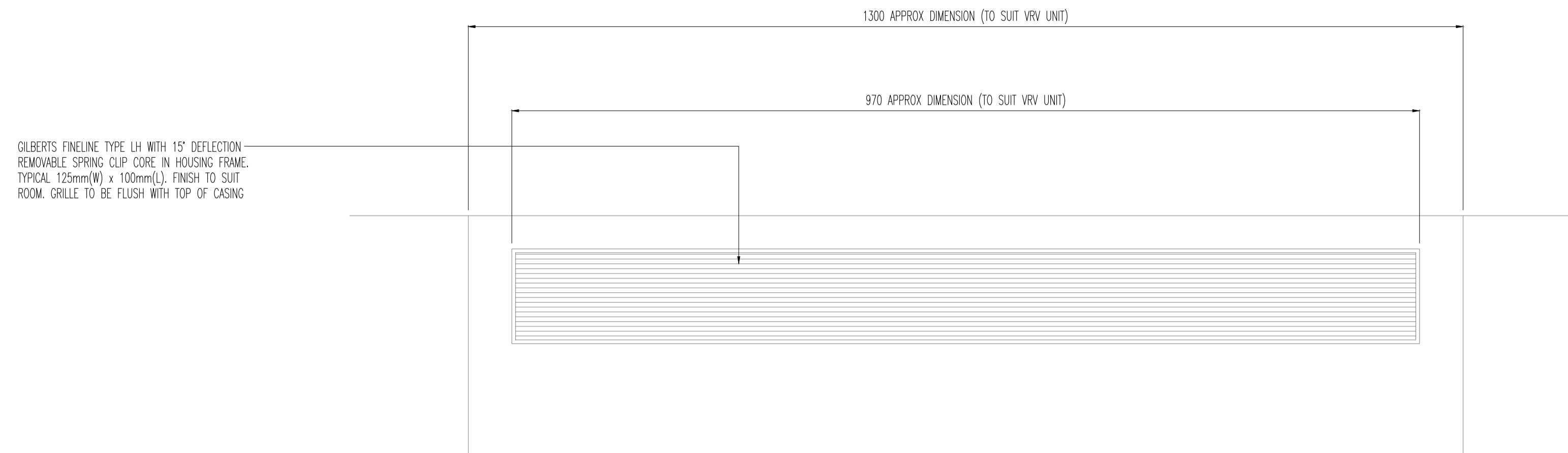

TOP VIEW

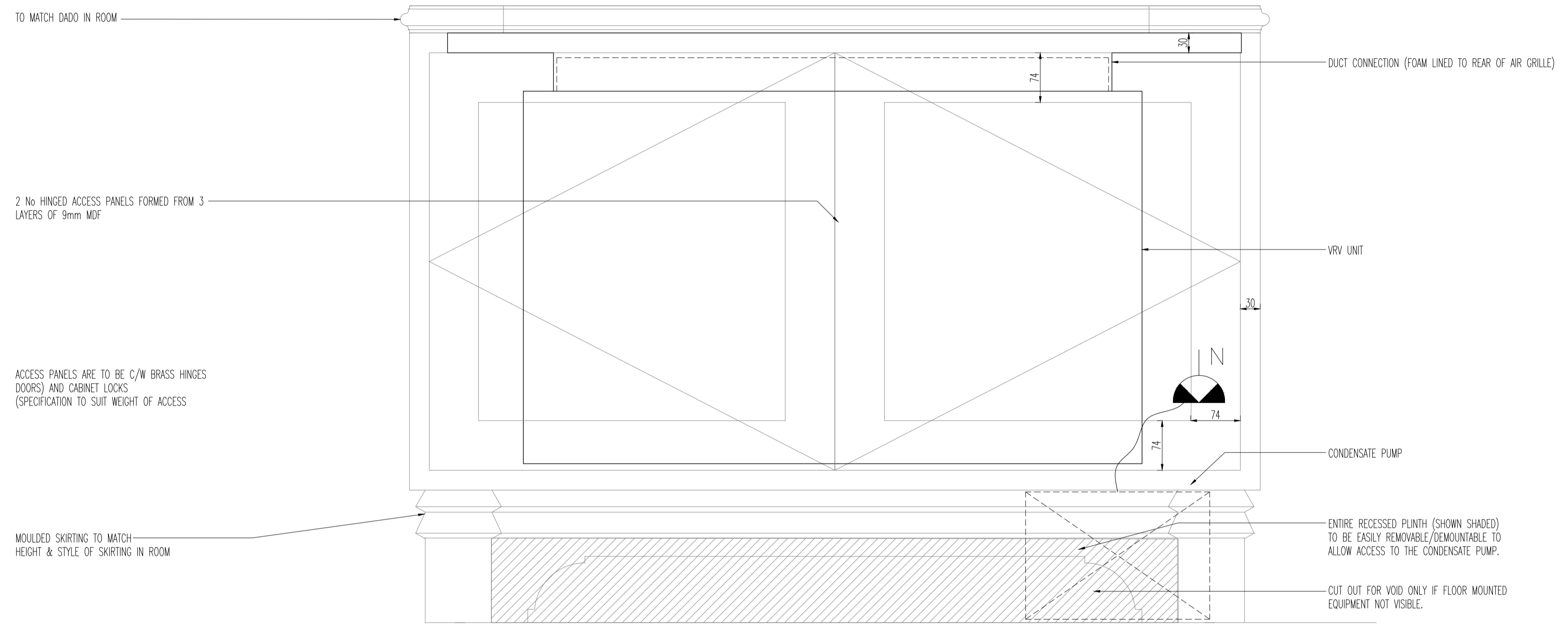

FRONT VIEW

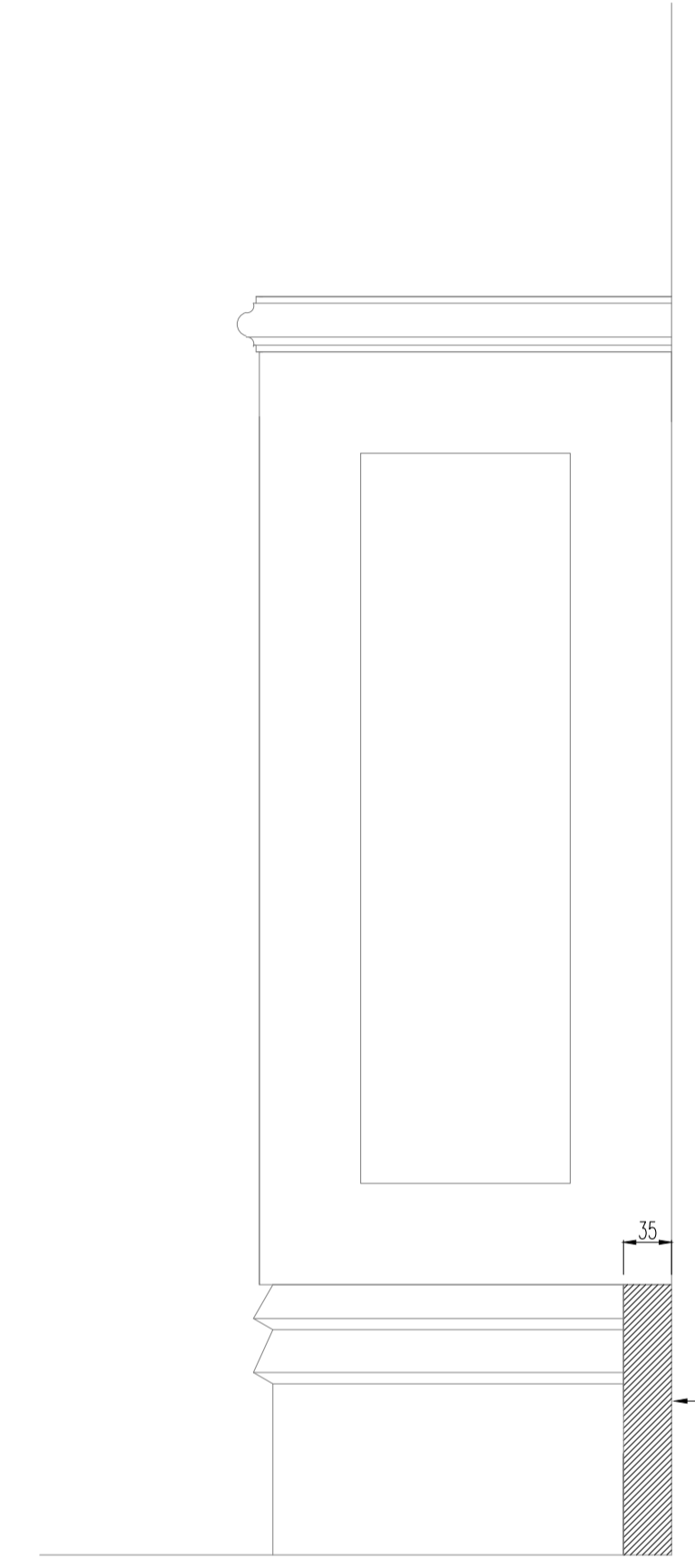

SIDE VIEW

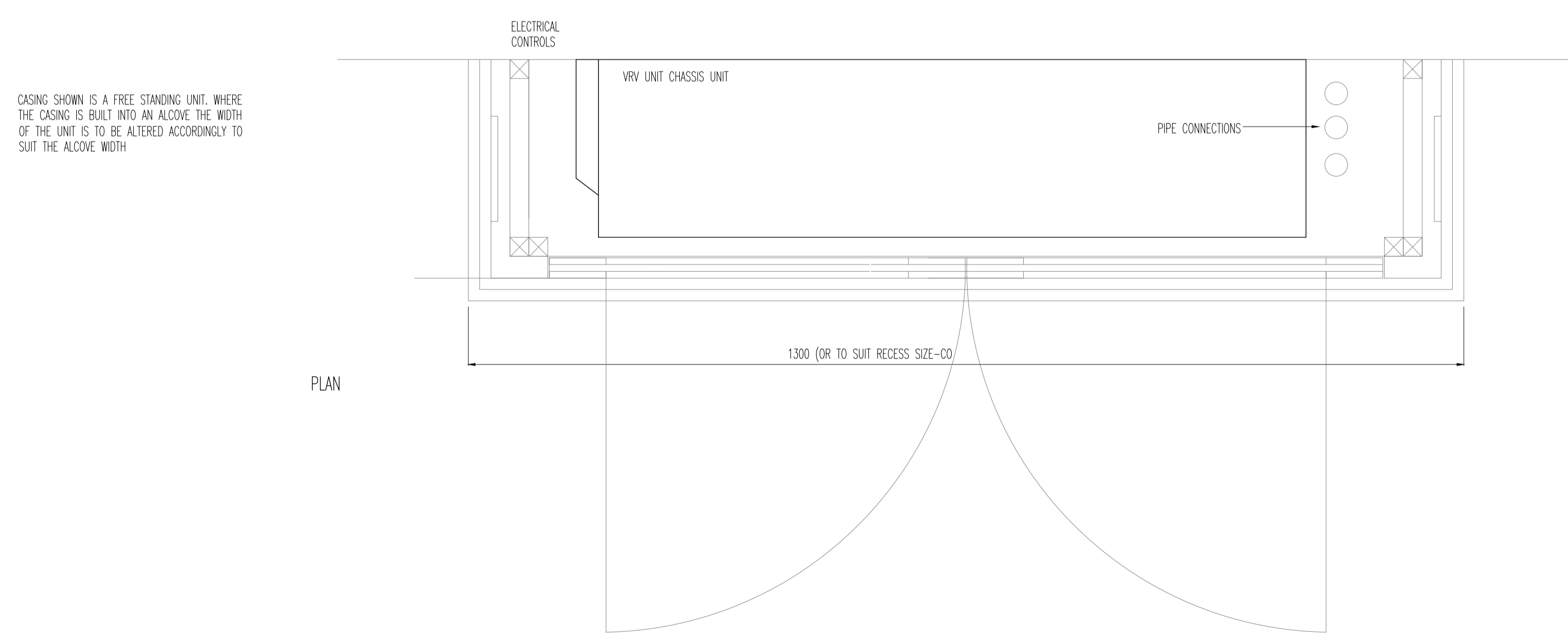

PLAN

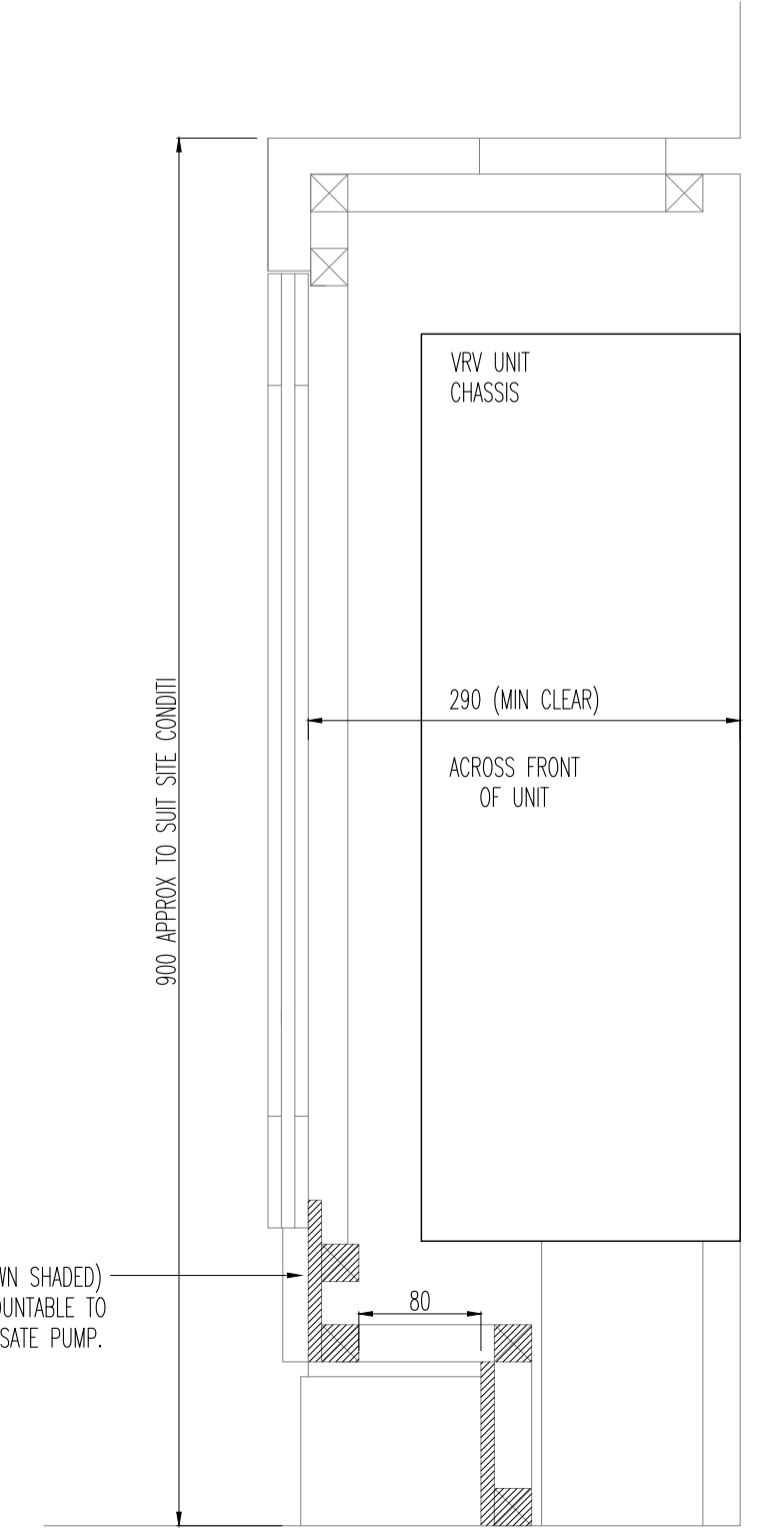

SECTION

CILBERTS FINELINE TYPE LH WITH 15° DEFLECTION REMOVABLE SPRING CLIP CORE IN HOUSING FRAME. TYPICAL 125mm(W) x 100mm(L). FINISH TO SUIT ROOM. GRILLE TO BE FLUSH WITH TOP OF CASING

TO MATCH BADO IN ROOM

2 No HINGED ACCESS PANELS FORMED FROM 3 LAYERS OF 9mm MDF

ACCESS PANELS ARE TO BE C/W BRASS HINGES (DOORS) AND CABINET LOCKS (SPECIFICATION TO SUIT WEIGHT OF ACCESS)

MOULDED SKIRTING TO MATCH HEIGHT & STYLE OF SKIRTING IN ROOM

CASING SHOWN IS A FREE STANDING UNIT. WHERE THE CASING IS BUILT INTO AN ALCOVE THE WIDTH OF THE UNIT IS TO BE ALTERED ACCORDINGLY TO SUIT THE ALCOVE WIDTH

DUCT CONNECTION (FOAM LINED TO REAR OF AIR GRILLE)

VRV UNIT

CONDENSATE PUMP

ENTIRE RECESSED PLINTH (SHOWN SHADED) TO BE EASILY REMOVABLE/DEMOUNTABLE TO ALLOW ACCESS TO THE CONDENSATE PUMP.

CUT OUT FOR VOID ONLY IF FLOOR MOUNTED EQUIPMENT NOT VISIBLE.

VRV UNIT PLINTH IS TO BE STOPPED SHORT OF WALL TO ALLOW EXISTING SKIRTING TO PASS BEHIND.
PROVIDE A BLANKING PANEL (SHOWN SHADED) RECESSED 18mm BEHIND FACE OF CASING. BLANKING PANEL TO BE CAREFULLY SCRIBED AROUND SKIRTING.

ENTIRE RECESSED PLINTH (SHOWN SHADED) TO BE EASILY REMOVABLE/DEMOUNTABLE TO ALLOW ACCESS TO THE CONDENSATE PUMP.

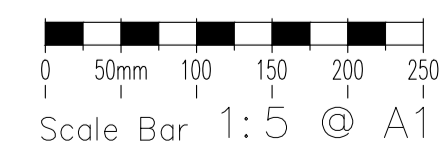

PLANNING

0	FEB.19	PLANNING ISSUE
Rev	Date	Description

TPS

Taylor Project Services LLP

No.1 Cornhill
London EC3V 9ND
Tel 020 7743 6602
www.taylorprojectservices.com

Client

29a Montague Street
London
WC1B 5BL
Tel 0771 66 2988
Fax 0771 251 1729

Project
**13 BEDFORD SQUARE
LONDON
WC1**

Drawing Title
**VRV JOINERY CASING DETAIL
(LOWER GROUND, GROUND &
& FIRST FLOOR)**

Scale 1:5 @ A1	Date AUG.18
Drawn L.R.	Checked G.N.T.

Drawing Status
PLANNING

Revision 0									
------------	--	--	--	--	--	--	--	--	--

Drawing No. **TPS/13BS/VRV/J**

THIS DRAWING MUST NOT BE REPRODUCED WITHOUT PRIOR CONSENT.
DO NOT SCALE FROM THIS DRAWING.
THIS DRAWING IS COPYRIGHTED

GENERAL NOTES

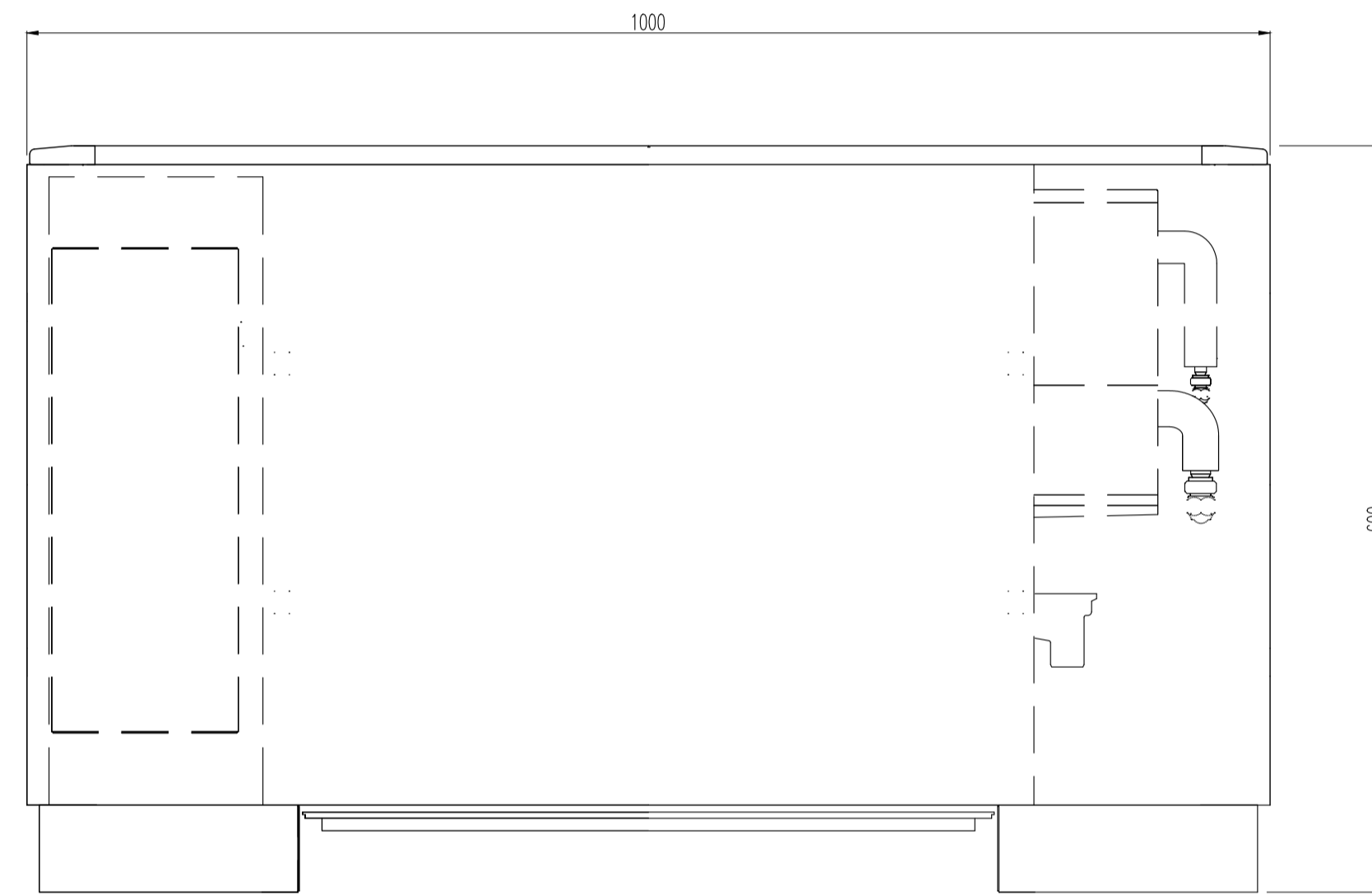

FRONT VIEW

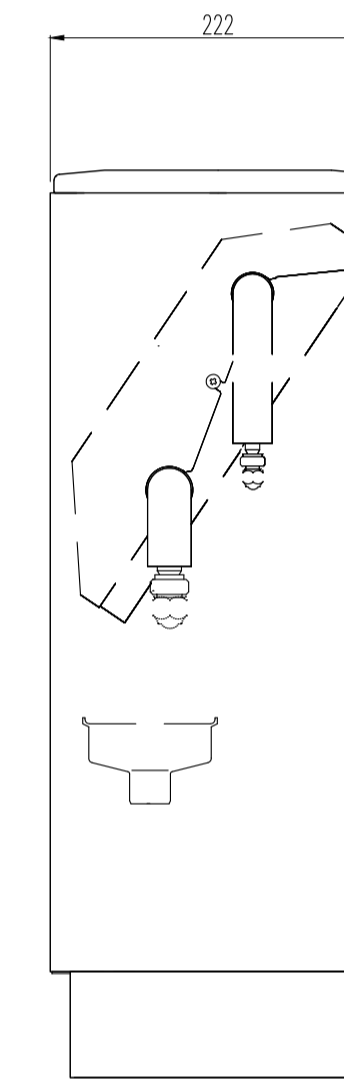

SECTION

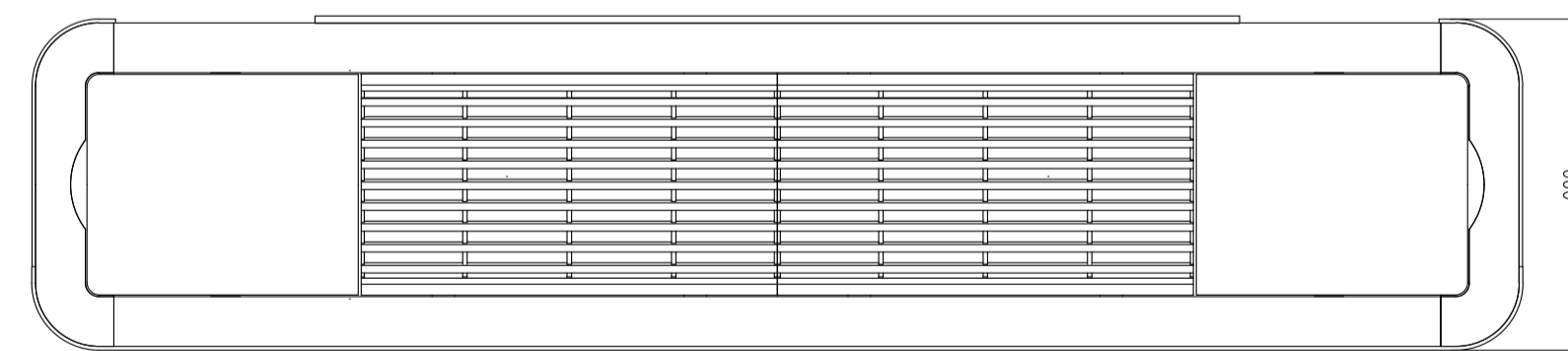

PLAN

DAIKIN PROPRIETARY METAL CASED VRV UNITS



PLANNING

Rev	Date	Description
0	FEB.19	PLANNING ISSUE

TPS

Taylor Project Services LLP

No.1 Cornhill
London EC3V 9ND
Tel 020 7743 6602
www.taylorprojectservices.com

Client



THE BEDFORD ESTATES
29a Montague Street
London WC1B 5BL
Tel: 0201 636 2968
Fax: 0201 255 1229

Project
13 BEDFORD SQUARE
LONDON
WC1

Drawing Title
VRV STANDARD CASING DETAIL
(SECOND & THIRD FLOORS)

Scale 1:5 @ A1	Date AUG.18
Drawn L.R.	Checked G.N.T.

Drawing Status
PLANNING

Revision	0																		
----------	---	--	--	--	--	--	--	--	--	--	--	--	--	--	--	--	--	--	--

Drawing No. TPS/13BS/VRV/M

TPS 1

THIS DRAWING MUST NOT BE REPRODUCED
WITHOUT PRIOR CONSENT.
DO NOT SCALE FROM THIS DRAWING.
THIS DRAWING IS COPYRIGHT. ©

NOTES

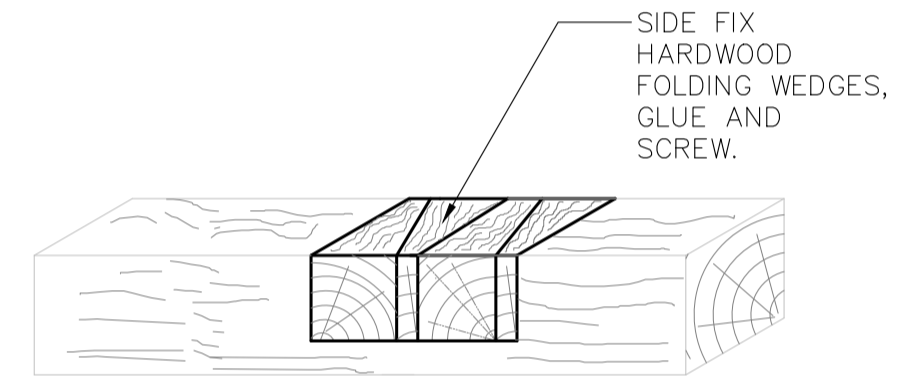

NOTCH REPAIR DETAIL
FOR LONG NOTCH
FOR NOTCHES GREATER THAN 25mm DEEP.

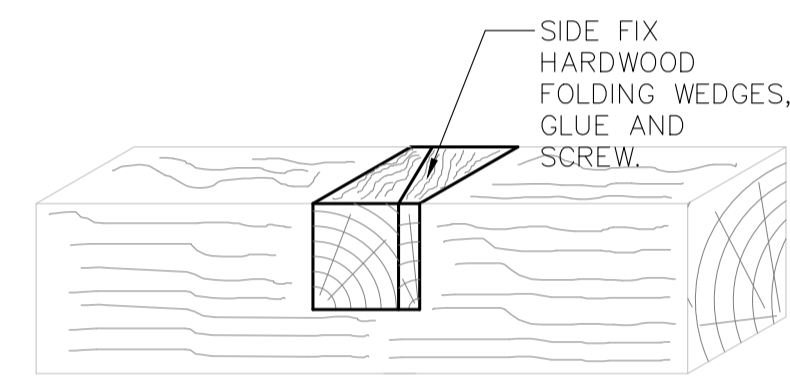

NOTCH REPAIR DETAIL 2
FOR NOTCHES GREATER THAN 25mm DEEP.

TPS
Taylor Project Services LLP

No.1 Cornhill
London
EC3V 3ND
Tel 020 7743 6602
www.taylorprojectservices.com

Project
13 BEDFORD SQUARE
LONDON
WC1

Drawing title
TIMBER LARGE NOTCH REPAIR

Scale 1:20@A3
Date AUG.18
Drawn L.R.
Chkd G.N.T.

Rev	Date	Description	Rev
0	FEB.19	PLANNING ISSUE	
		Dwg No. 13BS-TN2	0
		Status PLANNING	