

Notes:

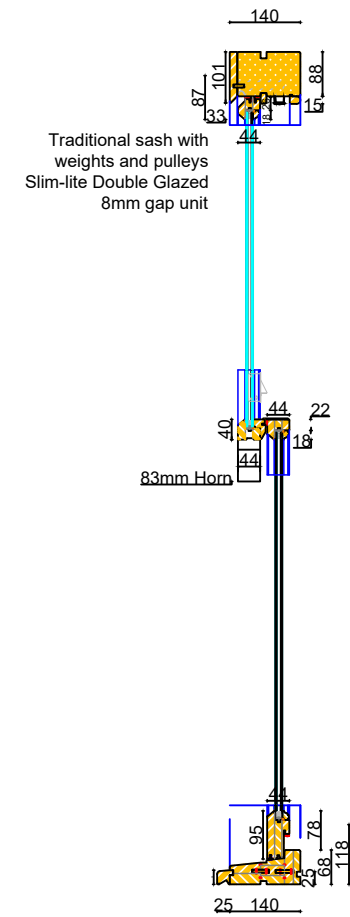
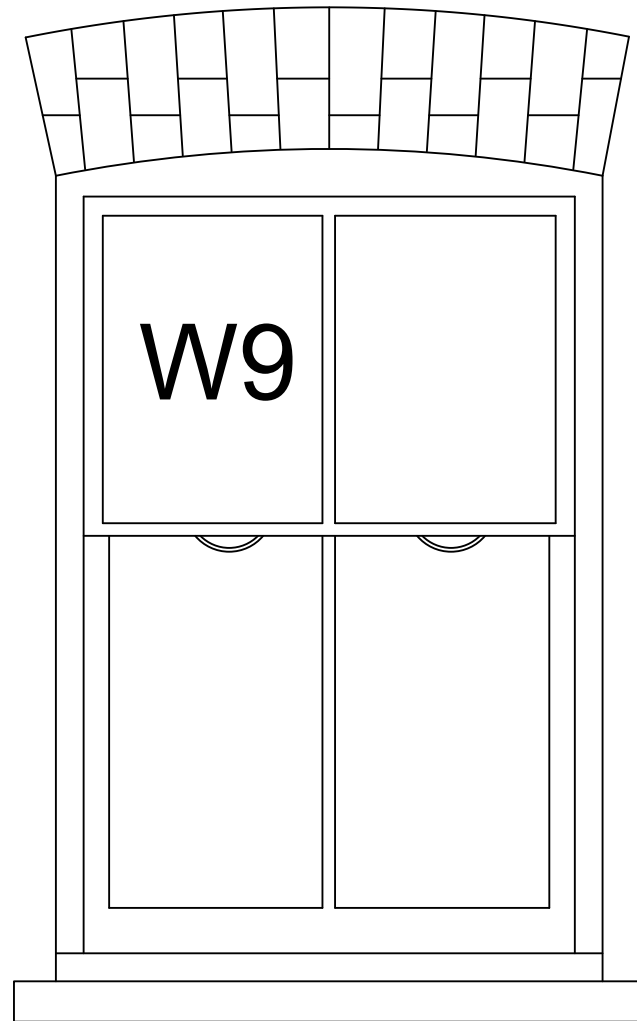

EMPLOYER'S AGENTS & PROJECT MANAGERS  
UNIT A COURT HOUSE, 11A HIGH STREET  
BARNET EN5 5UJ  
TEL: 020 8446 5537  
E-MAIL: Planning@walkercc.co.uk

TITLE  
**Window Section**

PROJECT  
122 Maygrove Road

CLIENT  
GENESIS HOUSING ASSOCIATION / KIER

SCALE: AS IDENTIFIED  
CAD FILE: -  
DATE: 30.08.18  
DRAWN BY: RBM  
CHECKED:

PROJECT NO.	DRAWING NO.	REVISION
4223	4223/WM/04	1