

# Waste Management Plan

---

1 Hurdwick Place, Mornington Crescent, London, NW1 2JE



Project Reference	GAA-00452
Document Number	A01-NL-R3-01-WM
Revision Number	P02
Date	30 <sup>th</sup> November 2018
Written By	Carmen Sala
Reviewed By	Sundeep S Bhavra

# Contents

---

<b>Waste Storage Design</b>	<b>04</b>
0. Location Plan	04
1. Waste & Recycling containers and quantities	05
2. Size of Containers	06
3. Waste Storage and Collection Strategy	06
<b>Appendix 1.0</b>	<b>07</b>

# Waste Storage Design

The following specification shall be read in conjunction with the relevant drawings supplied.

## 0. Location Plan

The site currently comprises a two-storey dwelling with a commercial property located on the ground floor just off Hampstead Road and adjacent to Mornington Crescent Tube Station.

The site is an end terrace building. When the site walkover was undertaken (Dec 2017) 2 Hurdwick Place is undergoing renovations and is using the carpark associated with Hurdwick House to gain access to the rear of the property.

The proposal involves the erection of an infill side extension at second and third floor level and a rear part single part double storey rear extension between first and second floor level to provide 2 x studio flats, 1x 3bed self-contained flat and 1 x 2bedroom residential flats..

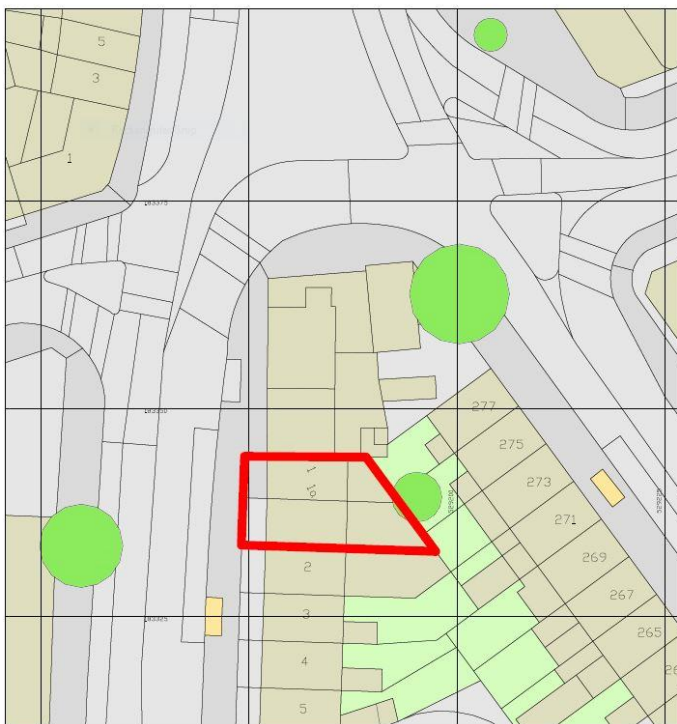

Location plan 1/500



Block plan 1/1250

## 1. Waste & Recycling containers and quantities

- 2x Studio Flats: 2x100 l
- 1x 2B Flat: 1x170 l
- 1x3B Flat: 1x 240 l

**Total: 610 l**

- Refuse: 2x240 l
- Recycling: 2x240 l
- Food Waste: 1x240 l

## 2. Size of Containers

- The 240 litre container for non-recyclable household waste has the following dimensions: Width 570 mm, Height 1,140 mm, and Length 535 mm;
- The 240 litre container for mixed dry recycling has the following dimensions: Width 570 mm, Height 1,140 mm, and Length 535 mm;
- The 240 litre container for organic waste has the following dimensions: Width 570 mm, Height 1,140 mm, and Length 535 mm;

### **240 Litre Wheellie Bin**

- A = 1070mm
- B = 740mm
- C = 570mm
- D = 535mm
- E = 995mm
- F = 550mm
- G = 1140mm
- Weight 15.5Kg

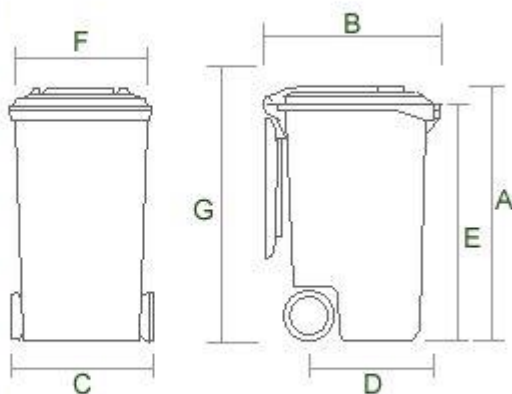

(Dimensions are a guide only)

### 3. Waste Storage and Collection Strategy

The development is designed to ensure that sufficient waste storage space is provided within a well-used area of each of the units. The internal waste storage provision will assist in promoting the segregation of residual (non-recyclable) and recyclable materials at source. Indeed, all households will be responsible for segregating their generated waste at source into nonrecyclable and mixed-recyclable waste streams.

Residents will be responsible for manually transporting their waste to the bin stores where they will deposit it into the appropriate waste container. All bins and waste storage areas will be clearly labelled to prevent cross contamination of residual waste and recyclable waste. The Landlord will be responsible of wheelied the bins to Hurdwick Place the day of the collection (every Friday) between 06:00-14:00h, via a Management company who will be responsible of moving the bins from the waste store to the street and putt them back with a Cargomaster Powered Stair Climbers C141 Vario (or similar approved) to transport the bins over the stairs at Front Entrance. This Stair-Climber sack truck is foldable and will be store in the waste storage.

All residential waste collection will be undertaken by the London Borough of Camden (LBC) with weekly collections for each of the waste streams. LBC refuse vehicles will be able to access the site along Hurdwick Place.



# Appendix 1.0

---

Waste Storage Plan





**GAVA**

g a a . d e s i g n