

REFUSE AND RECYCLING METHODS

Container Dimensions and Specifications

Container	Dimensions			Equivalent in black bags
	Width	Depth	Height	
140 litre wheeled bin* 	555mm	500mm	1100mm	2
360 litre wheeled bin* 	880mm	580mm	1100mm	3 - 4
660 litre euro bin 	1205mm	775mm	1340mm	7 - 8
1100 litre euro bin 	1205mm	980mm	1340mm	14 - 15

*Dependant on service

We [employ cookies](#) to provide you with better performance and offer you a better online experience. If you continue without changing your settings, we presume that you consent to our use of these cookies.

OK

BLANCO SELECT 60/2

Pros



The best SELECT by BLANCO: waste system and cabinet organisation of the new generation.

- Modern, harmonious and functional design
- Integrated construction prevents dirt
- All parts are easy to clean
- High quality system cover that can simply be pulled out
- Unbeatably quick and easy to install
- Optional: Practical accessories such as the SELECT CLIP bin liner holder, the BLANCO SELECT AutoMove electric opening system or the BLANCO MOVEX foot pedal for BLANCO SELECT and all pull-out fronts
- Functionally designed bins and visually integrated handles

Details

Item No.

518723 Front door and side walls

Scope of supply

30 l and 19 l bins

Design tips

Installation height 361 mm, installation depth 400 mm, required inside dimension of cabinet 450 mm.

- Door fronts must not have hinges or holes. Take position of handle into account.
- Can also be installed in cabinets with panelled doors with 40 mm frame.
- Consider the installation height of the waste system, installation depth of the sink and the resultant minimum measure of the cabinet right from the planning.
- Minimum recommended plinth height for the installation of MOVEX: 100 mm.

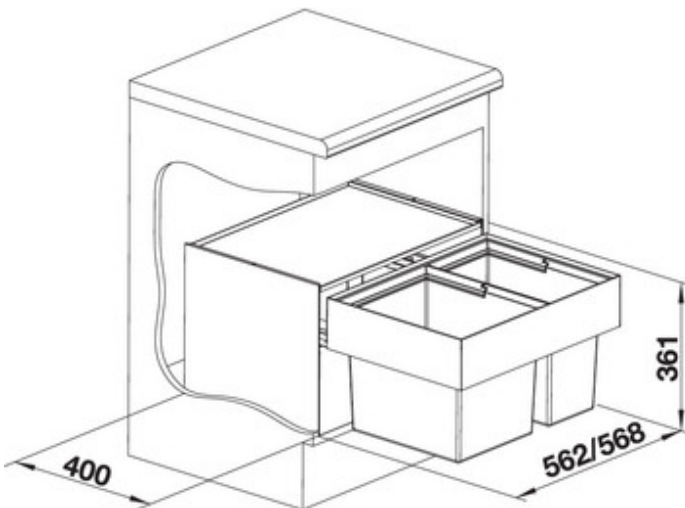

Product view

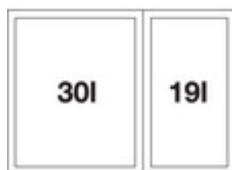

Top View



FWD-050SS



*Efficient and reliable
Supreme grinding efficiency
Silent DC motor
Hygienic & convenient
Warranty 5-Year in-home service*

Knock-out for dishwasher drain

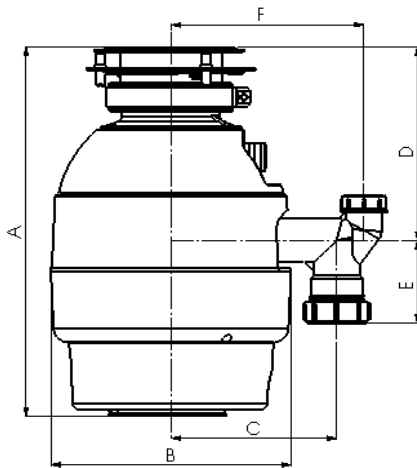

Measurements in Millimeters

A : 335	B : 205
C : 141	D : 175
E : 75	F : 165

Features

- 1/2 Horsepower with high-speed permanent magnet motor 5500 rpm
- Fast grinding technology
- Corrosion proof stainless steel
- Manual reset for overload protection
- Handy wall switch operation
- Easy and convenient installation
- Trendy and unique gun metal color

Specifications

- Motor Speed : 5500 rpm
- Horsepower : 1/2 HP
- Voltage : 220-240 V
- Frequency: 50 Hz
- Current : 2.6 A
- Type of feed : Continuous
- Motor type : Permanent magnet DC motor
- Sound shell: Yes
- Overload protection : Manual reset
- Individual shipping weight : 5.5 kg

Materials

- Sink flange : Stainless steel
- Hopper : Glass filled nylon
- Swivel impeller : Stainless steel
- Grind ring : Stainless steel
- Turntable : Stainless steel

Optional accessories

- Lock Mount
- Sink Baffle
- Stopper
- Flange
- Plumbing Kit



Evolution 100 Food Waste Disposer

The Evolution 100 food waste disposal unit is more powerful and quieter than our standard M-Series range. Kitchen convenience is guaranteed with the 2-stage grind technology, .75 hp motor, auto reverse grind system, 5 year warranty and much more

Features



Quieter



Stainless
Steel
Stopper



Quick-
Lock™
Mounting



Powerful
Induction
Motor



Environmentally
Responsible

PRODUCT SPEC SHEET

Evolution 100
Food Waste
Disposer

Specifications

- Continuous Feed
- Built-In Switch
- Single Phase Motor
- Auto-Reverse Grind System
- Time Rating: Intermittent
- Permanently Lubricated Upper & Lower Bearings
- Shipping Weight (Approx): 8.8 kg
- Overall Height: 312mm
- 2-Stage Grind Technology
- Grind Chamber Capacity: 1005ml
- Motor Protection: Manual Reset Overload
- Average Water Usage: Approximately 5L per Person Per Day
- Drain Connection: 1-1/2" (3.81cm)
- Average Electrical Usage: 2-3 KWH per Annum
- Dishwasher Drain Connection

Dimensions (mm)

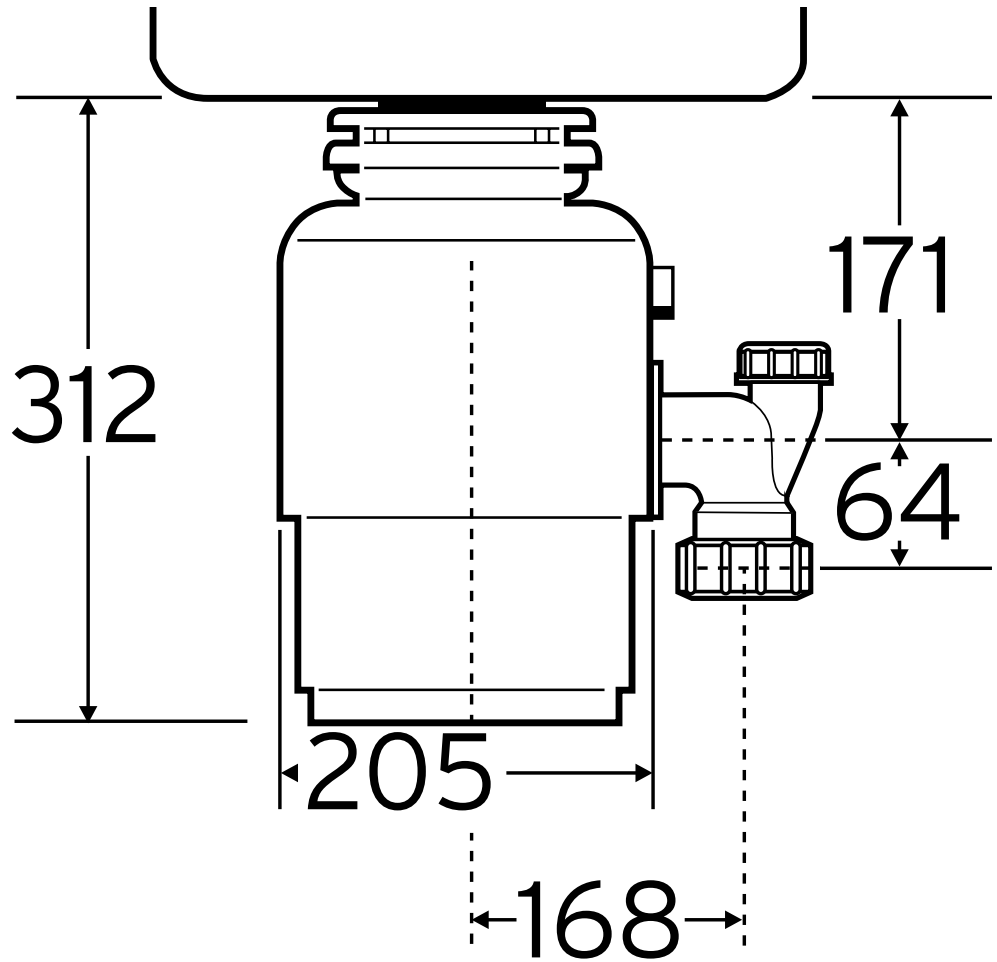

Volts/Hz	HP	RPM	Average Load
120V, 60Hz	.75	1725	8.1 A
220-240V, 50 Hz	.70	1425	380 W
220-240V, 60 Hz	.70	1725	380 W

InSinkErator
Suite 10, Building 6
Hatters Lane
Croxley Green Business Park
Watford, Herts WD18 8YH
United Kingdom
Sales tel: 01923 297 880
Service tel: 0800 389 3715
www.insinkerator.co.uk

InSinkErator
Emerson Electric Co.
4700 21st Street
Racine, WI 53406-5093 USA
Sales/Service tel: +1 262-554-5432
www.insinkerator.com/worldmap.html