

CC Atrium Block N1

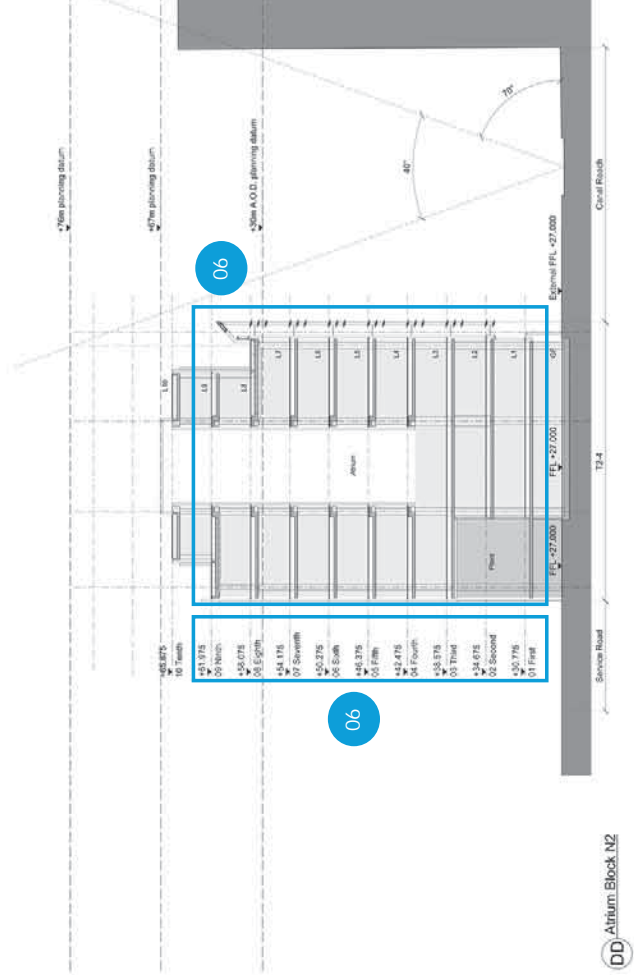

DD Atrium Block N2

- 01. Change of use from D1 to B1 in Building T2 and from flexible B1 to A1-A4/B1/D1/D2 in Building T3, at ground floor, with subsequent reconfiguration of those spaces.
- 02. Replacement of vertical brise-soleil with horizontal brise-soleil.
- 03. Amendments to roof levels.
- 04. Introduction of lift at Levels 0-3.
- 05. Reconfiguration of cycle changing rooms at Level 1.
- 06. Finished floor levels, structural slab levels and spandrel heights amended.
- 07. Atria enclosure removed.

**BENNETTS ASSOCIATES**  
 1 Newcombe Place, London EC1V 7PL  
 T +44(0)207 5203300 • www.bennettsassociates.com

Project **Site T2 KXC**  
 Kings Cross Central Partnership Ltd.  
 Drawing Title **Atrium Sections CC / DD**

Project No. 1503  
 Drawing Number **KXC-T2-001-A-1503-P20-201**  
 Scale @ A3 **1:250**  
 Scale @ A1 **1:500**  
 Revision Date **16/04/15**  
 Revision No. **01**  
 Revision Status **Rev. 01**



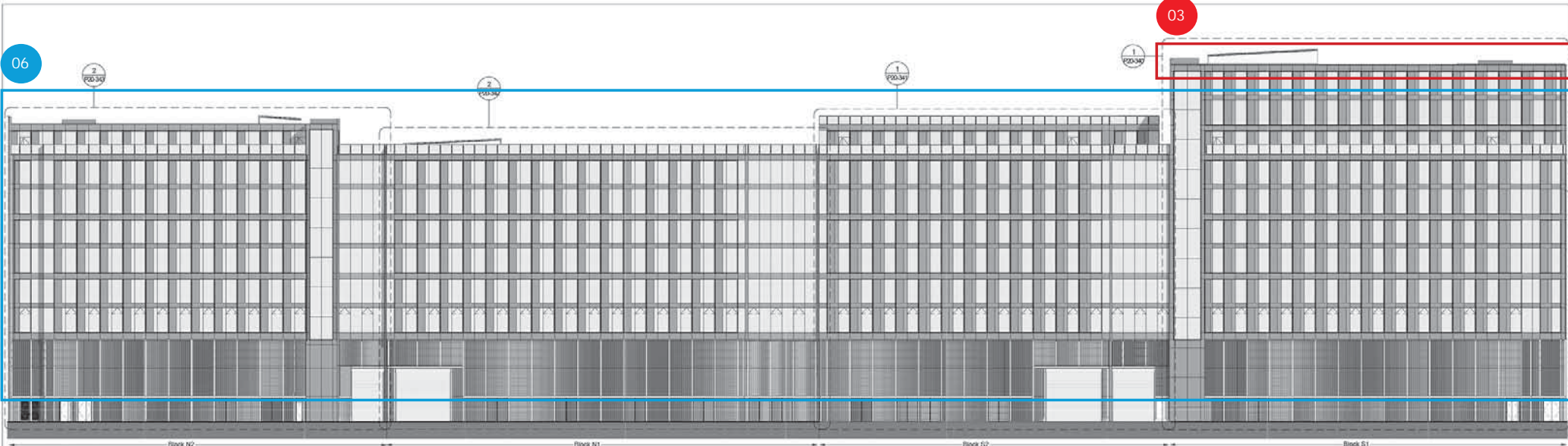

1- West Elevation

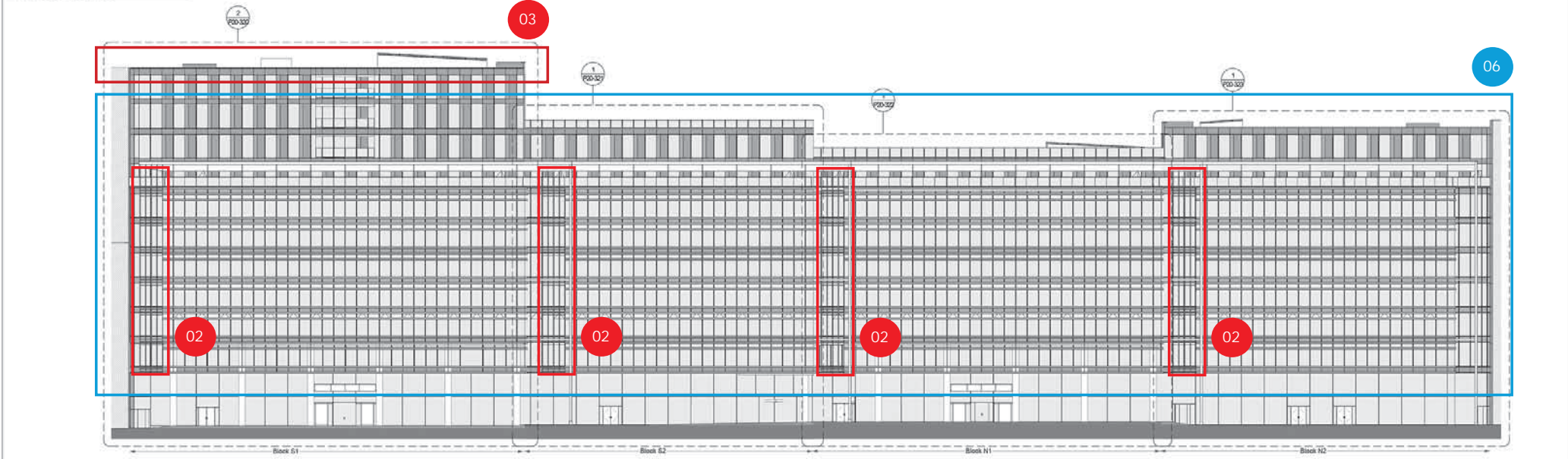

2- East Elevation

- 01. Change of use from D1 to B1 in Building T2 and from flexible B1 to A1-A4/B1/D1/D2 in Building T3, at ground floor, with subsequent reconfiguration of those spaces.
- 02. Replacement of vertical brise-soleil with horizontal brise-soleil.
- 03. Amendments to roof levels.
- 04. Introduction of lift at Levels 0-3.
- 05. Reconfiguration of cycle changing rooms at Level 1.
- 06. Finished floor levels, structural slab levels and spandrel heights amended.
- 07. Atria enclosure removed.

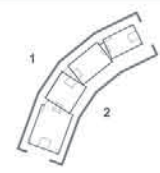

**BENNETTS ASSOCIATES**  
 1 Ravelston Place, London EC1V 7NL  
 T +44(0)207 0200900 • www.bennettsassociates.com  
 E ma@bennettsassociates.com

Project  
**Site T2 KXC**  
 Kings Cross Central Partnership Ltd.

Drawing Title  
 Elevations Tiles Identification

Drawing Number  
 KXC-T2-001-A-1503-P20-300

Project No. 1503

Revision  
 01

Scale @ A3 1:500    Scale @ A1 1:250    Revision Date 19/04/15  
 vvm/02



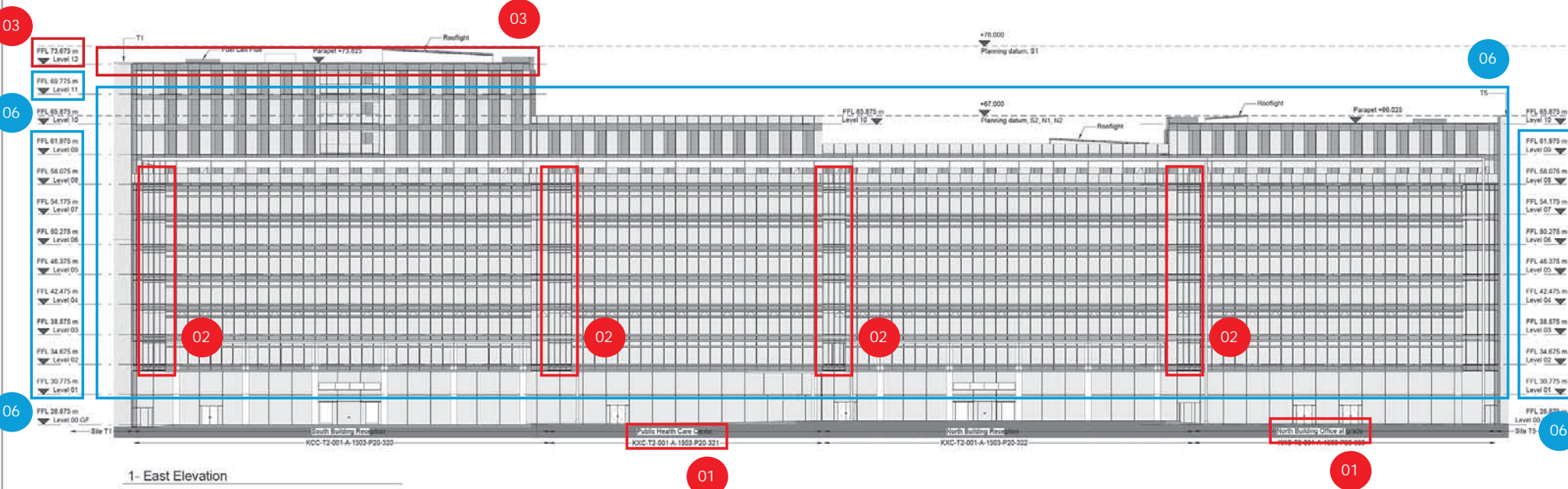

1- East Elevation

- 01. Change of use from D1 to B1 in Building T2 and from flexible B1 to A1-A4/B1/D1/D2 in Building T3, at ground floor, with subsequent reconfiguration of those spaces.
- 02. Replacement of vertical brise-soleil with horizontal brise-soleil.
- 03. Amendments to roof levels.
- 04. Introduction of lift at Levels 0-3.
- 05. Reconfiguration of cycle changing rooms at Level 1.
- 06. Finished floor levels, structural slab levels and spandrel heights amended.
- 07. Atria enclosure removed.



**BENNETTS ASSOCIATES**  
 1 Ravenstone Place, London EC1V 7HL  
 T +44(0)207 5200300 • www.bennettsassociates.com  
 E mail@bennettsassociates.com  
 For details to be used for any other project contact the author:  
 www.bennettsassociates.com/branding/

Project  
**Site T2 KXC**  
 Kings Cross Central Partnership Ltd.  
 Drawing Title  
**East Elevation**

Project No. 1503  
 Drawing Number  
 KXC-T2-001-A-1503-P20-302  
 Revision  
 01  
 Scale @ A3  
 1:500  
 Scale @ A1  
 1:250  
 Revision Date  
 15/04/15  
 7/1/2015



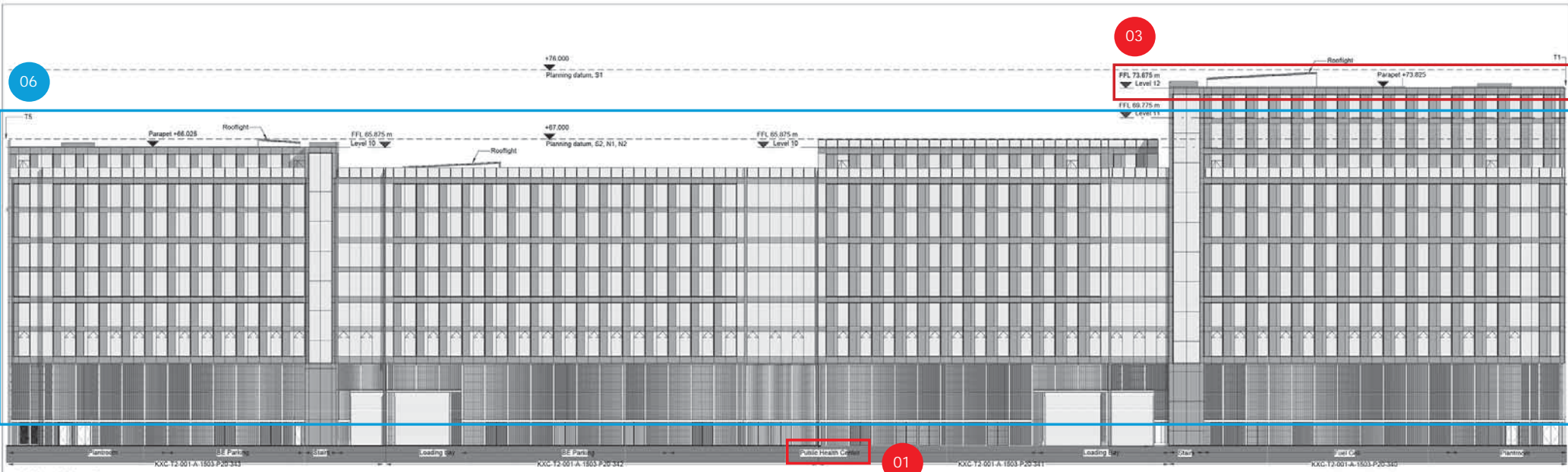

1- West Elevation

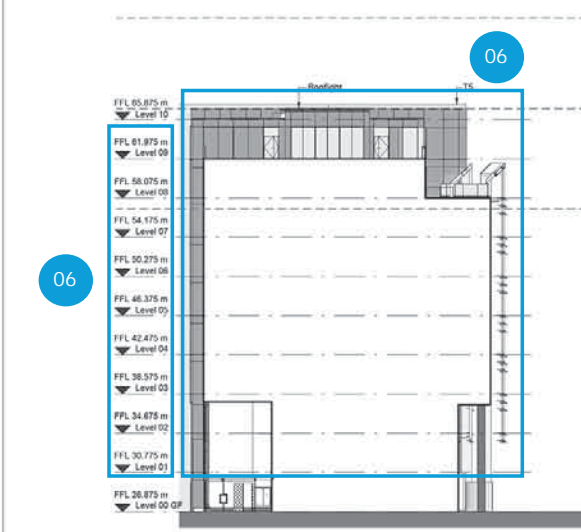

2- South Elevation N2

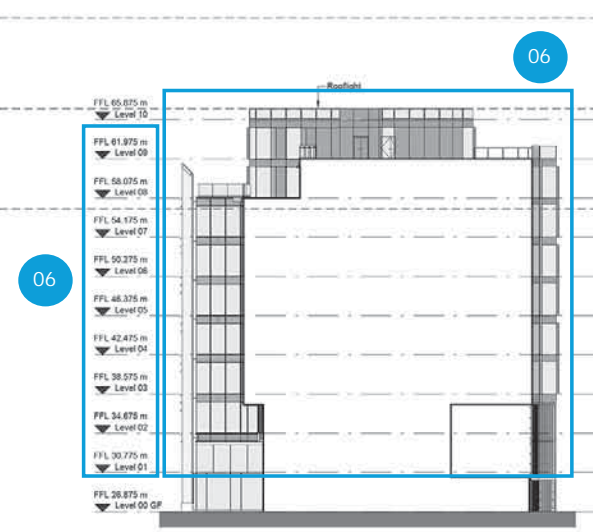

3- North Elevation Block S2

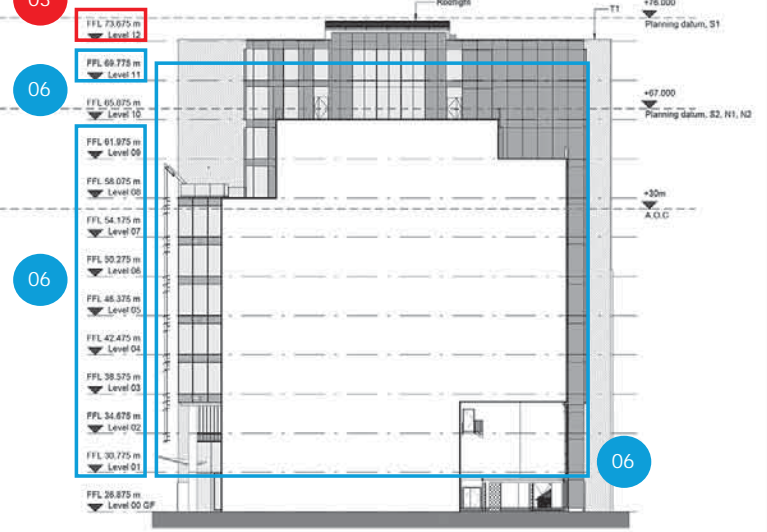

4- North Elevation Block S1

- 01. Change of use from D1 to B1 in Building T2 and from flexible B1 to A1-A4/B1/D1/D2 in Building T3, at ground floor, with subsequent reconfiguration of those spaces.
- 02. Replacement of vertical brise-soleil with horizontal brise-soleil.
- 03. Amendments to roof levels.
- 04. Introduction of lift at Levels 0-3.
- 05. Reconfiguration of cycle changing rooms at Level 1.
- 06. Finished floor levels, structural slab levels and spandrel heights amended.
- 07. Atria enclosure removed.

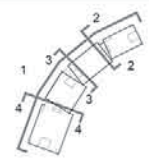

**BENNETTS ASSOCIATES**

1 Ravelston Place, London EC1V 7NL  
 T: +44(0)207 0200000 • www.bennettsassociates.com  
 E: info@bennettsassociates.com

Project  
**Site T2 KXC**  
 Kings Cross Central Partnership Ltd.

Drawing Title  
 West Elevation

Drawing Number  
 KXC-T2-001-A-1503-P20-304

Scale @ A3  
 1:500

Scale @ A1  
 1:250

Project No. 1503

Revision  
 01

Revision Date  
 15/04/15  
 vvm/02





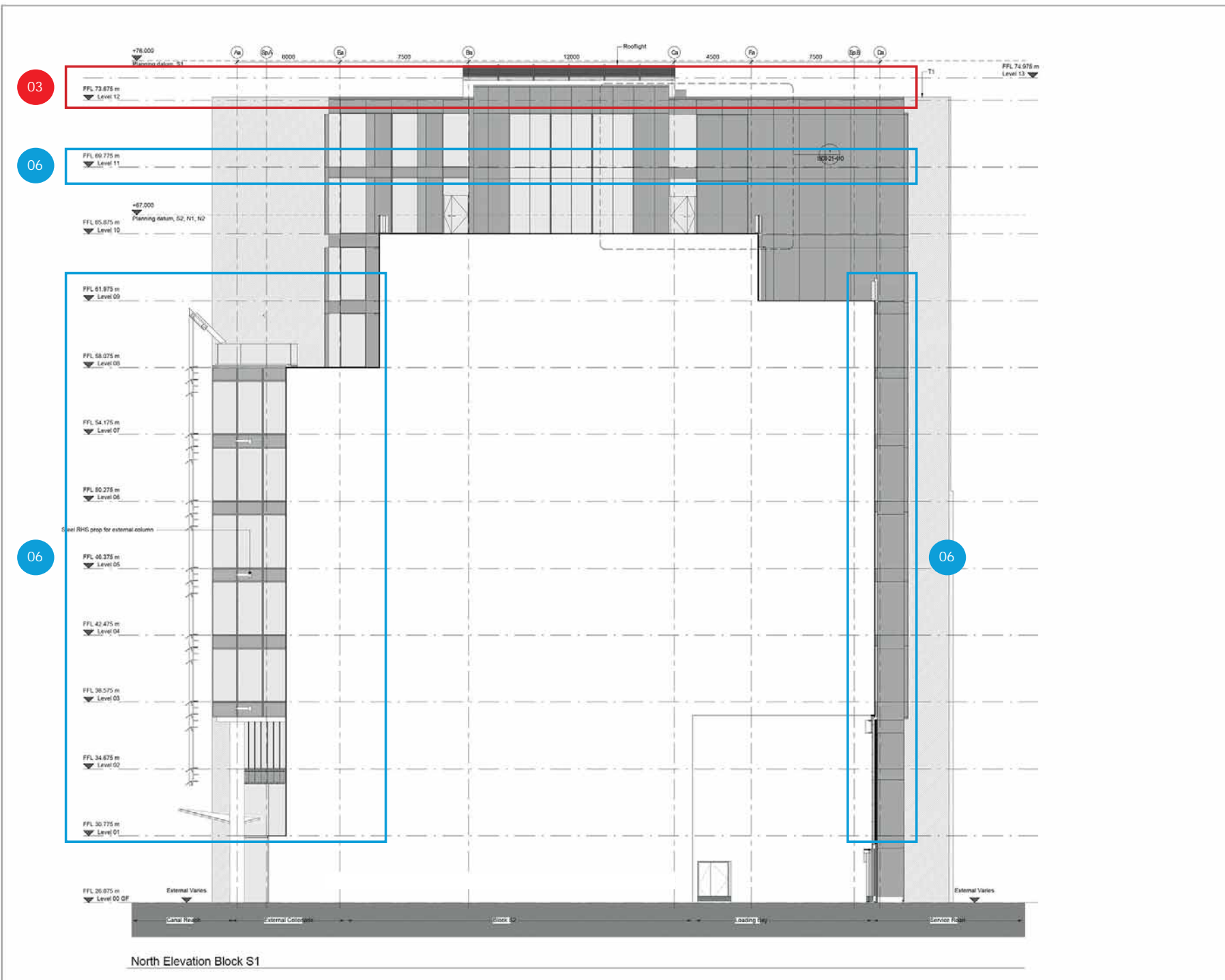

- 01. Change of use from D1 to B1 in Building T2 and from flexible B1 to A1-A4/B1/D1/D2 in Building T3, at ground floor, with subsequent reconfiguration of those spaces.
- 02. Replacement of vertical brise-soleil with horizontal brise-soleil.
- 03. Amendments to roof levels.
- 04. Introduction of lift at Levels 0-3.
- 05. Reconfiguration of cycle changing rooms at Level 1.
- 06. Finished floor levels, structural slab levels and spandrel heights amended.
- 07. Atria enclosure removed.



**BENNETTS ASSOCIATES**  
 1 Resourton Place, London EC1Y 7JL  
 T: +44(0)207 4203351 - www.bennettsassociates.com  
 E: info@bennettsassociates.com

Project: Site T2 KXC  
 Kings Cross Central Partnership Ltd

Drawing Title: North Elevation - Block S1  
 Block S1

Drawing Number: KXC-T2-001-A-1503-P00-310  
 Revision/Subtitle: 01

Scale @ A3: 1:200  
 Scale @ A1: 1:100  
 Revision Date: 16/04/15

YYM/SJ

North Elevation Block S1



03

FFL 73.675 m  
Level 12

06

FFL 60.375 m  
Level 11

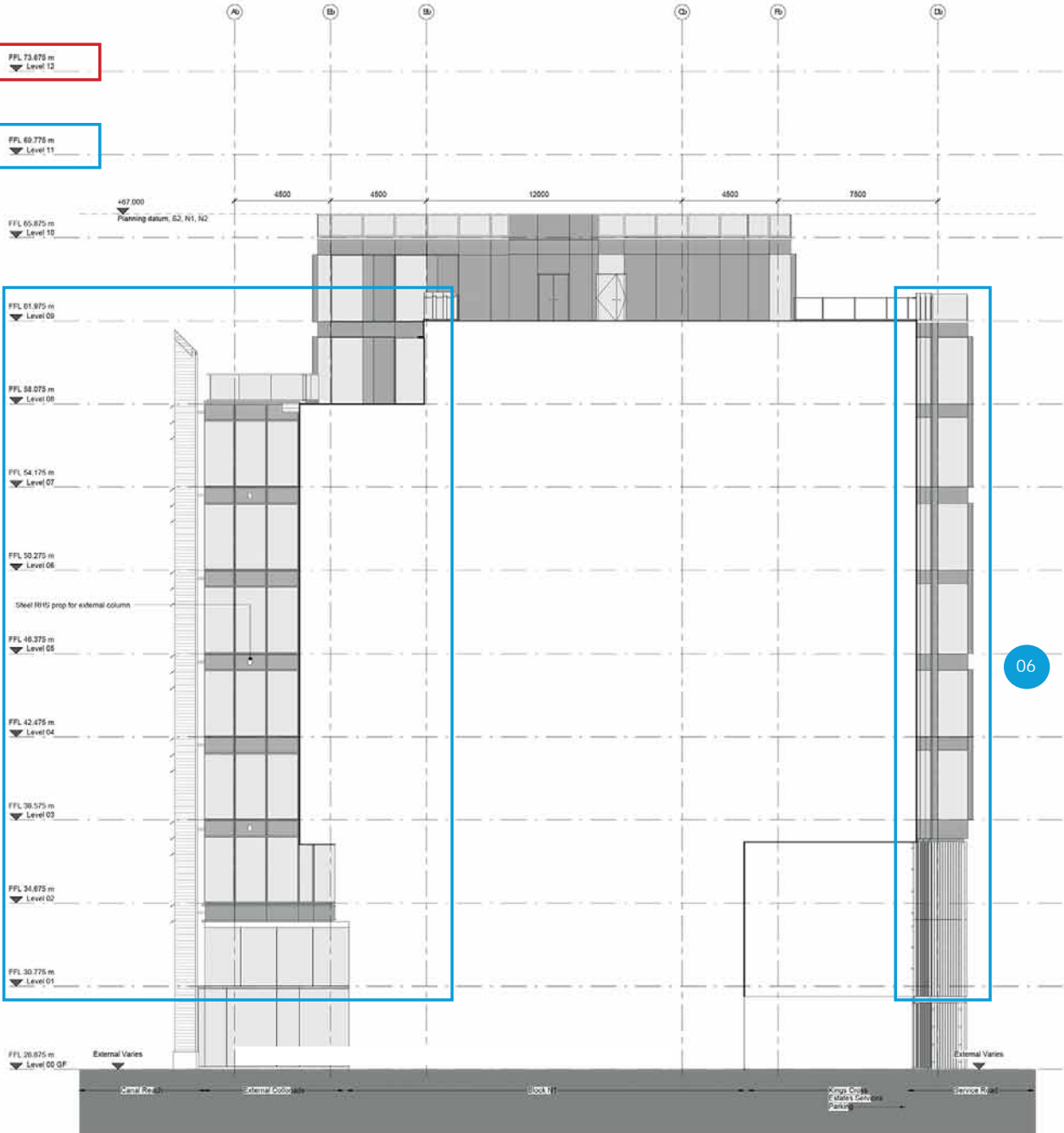

06

06

North Elevation Block S2

- 01. Change of use from D1 to B1 in Building T2 and from flexible B1 to A1-A4/B1/D1/D2 in Building T3, at ground floor, with subsequent reconfiguration of those spaces.
- 02. Replacement of vertical brise-soleil with horizontal brise-soleil.
- 03. Amendments to roof levels.
- 04. Introduction of lift at Levels 0-3.
- 05. Reconfiguration of cycle changing rooms at Level 1.
- 06. Finished floor levels, structural slab levels and spandrel heights amended.
- 07. Atria enclosure removed.



**BENNETTS ASSOCIATES**

1 Rouseburn Place, London EC1V 7PL  
 T +44(0)207 6300300 - www.bennettsassociates.com  
 E mail@bennettsassociates.com

Project Site T2 KXC  
 Kings Cross Central Partnership Ltd.

Drawing Title  
 North Elevation - Block S2

Block S2

Drawing Number  
 KXC-T2-001-A-1503-P20-311

Revision/Subtitle  
 01

Scale @ A3 1 : 200    Scale @ A1 1 : 100    Revision Date 16/4/15

YVMS/D



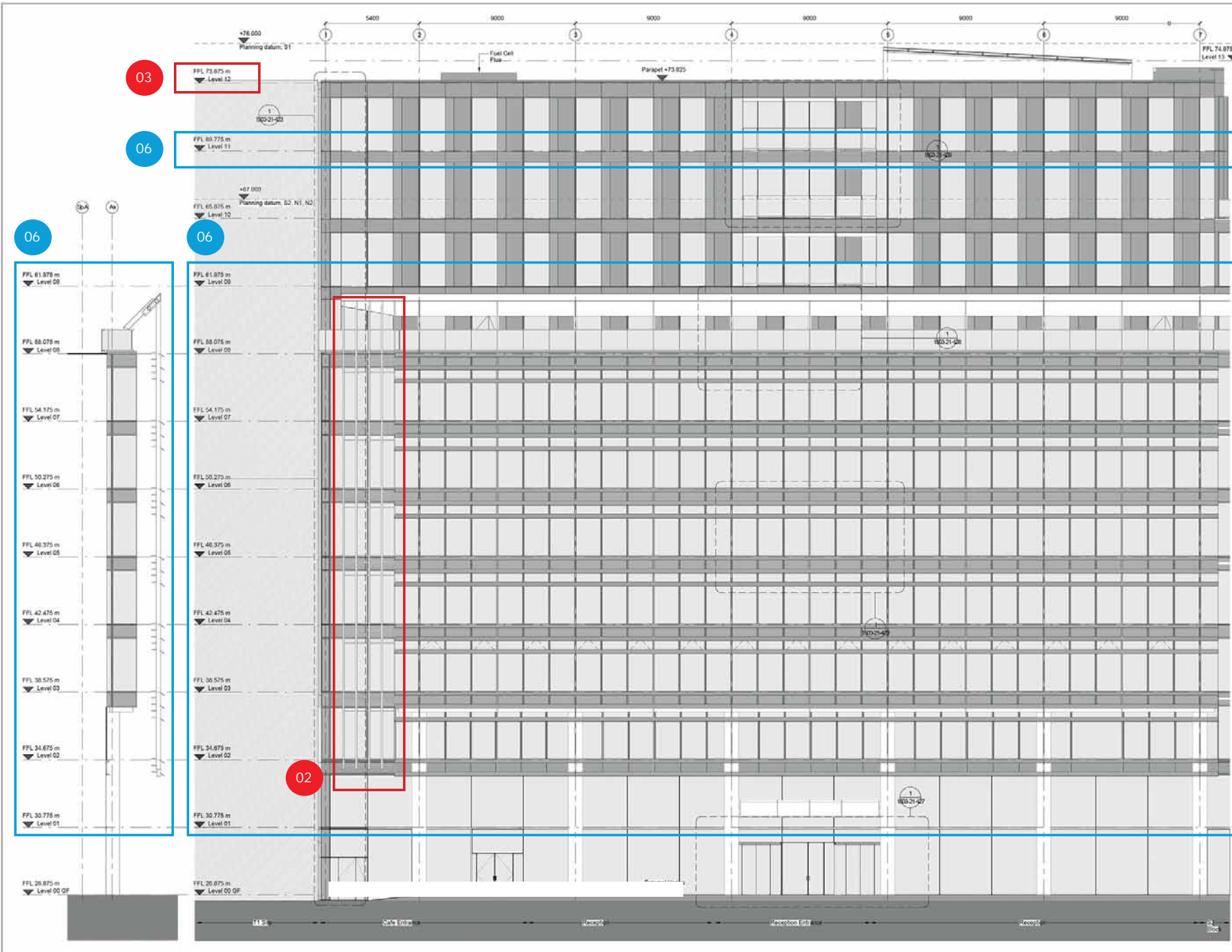

South Return Elev. S1

East Elevation S1

01. Change of use from D1 to B1 in Building T2 and from flexible B1 to A1-A4/B1/D1/D2 in Building T3, at ground floor, with subsequent reconfiguration of those spaces.
02. Replacement of vertical brise-soleil with horizontal brise-soleil.
03. Amendments to roof levels.
04. Introduction of lift at Levels 0-3.
05. Reconfiguration of cycle changing rooms at Level 1.
06. Finished floor levels, structural slab levels and spandrel heights amended.
07. Atria enclosure removed.



**BENNETTS ASSOCIATES**

1 Rousebone Place, London EC1V 7PL  
 T +44(0)20 74303333 - www.bennettsassociates.com  
 E mail@bennettsassociates.com

Project: Site T2 KXC  
 Kings Cross Central Partnership Ltd.

Drawing Title:  
 East Elevation - Block S1

Block S1

Drawing Number: KXC-T2-001-A-1503-P20-320  
 Revision/Subtitle: 01

Scale @ A3: 1:200  
 Scale @ A1: 1:100  
 Revision Date: 16/4/15  
 VVH/SJP



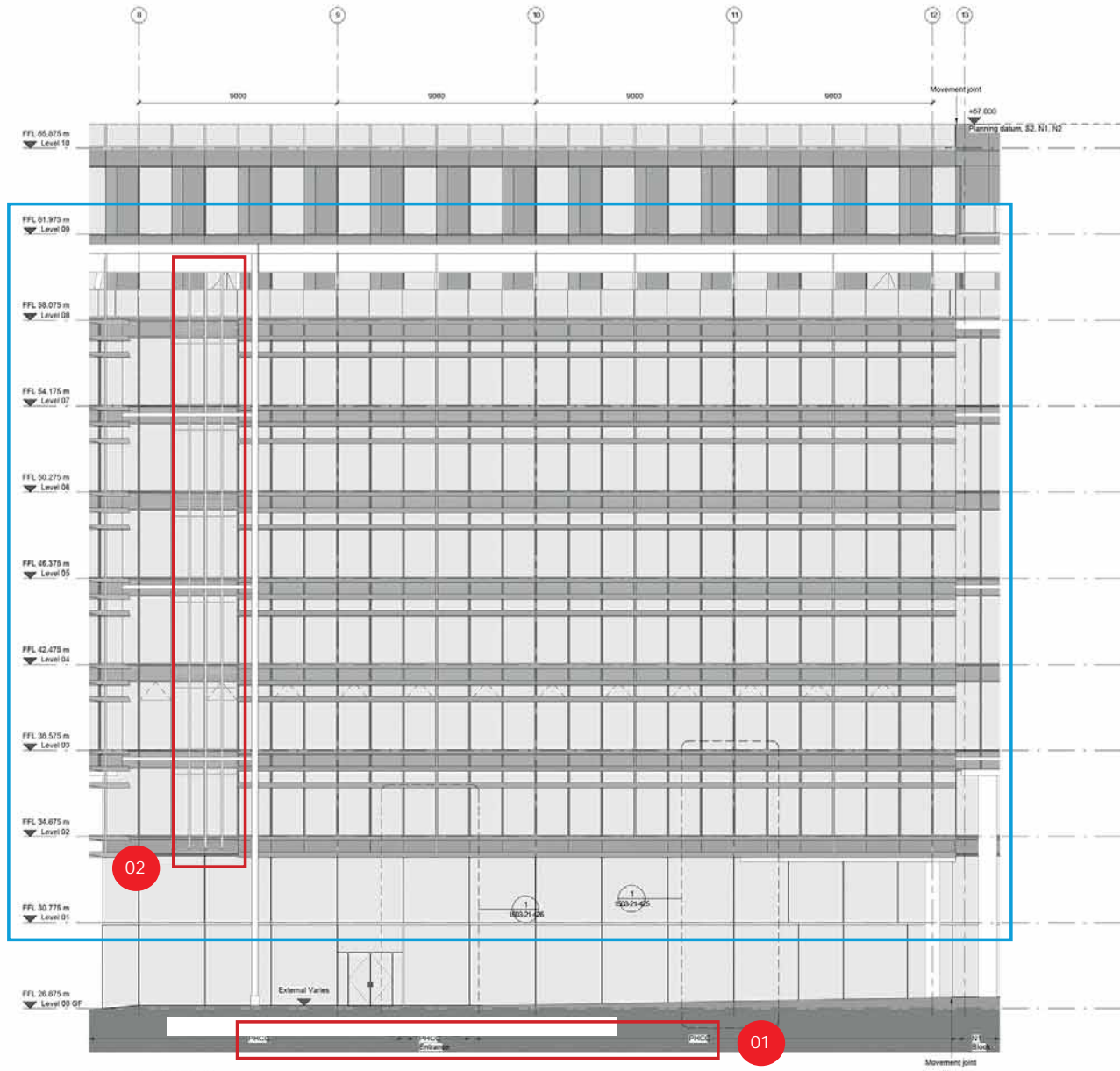

06

- 01. Change of use from D1 to B1 in Building T2 and from flexible B1 to A1-A4/B1/D1/D2 in Building T3, at ground floor, with subsequent reconfiguration of those spaces.
- 02. Replacement of vertical brise-soleil with horizontal brise-soleil.
- 03. Amendments to roof levels.
- 04. Introduction of lift at Levels 0-3.
- 05. Reconfiguration of cycle changing rooms at Level 1.
- 06. Finished floor levels, structural slab levels and spandrel heights amended.
- 07. Atria enclosure removed.



**BENNETTS ASSOCIATES**

1 Rousebone Place, London EC1V 7PL  
 T +44(0)20 7333 3333 • www.bennettsassociates.com  
 E mail@bennettsassociates.com

Project 1503  
**Site T2 KXC**  
 Kings Cross Central Partnership Ltd.

Drawing Title  
**East Elevation - Block S2**

Block S2  
 Drawing Number  
**KXC-T2-001-A-1503-P20-321**  
 Revision/Subtitle  
**01**

Scale @ A3 1 : 200  
 Scale @ A1 1 : 100  
 Revision Date  
 16/4/15  
 YVMS/D

East Elevation S2





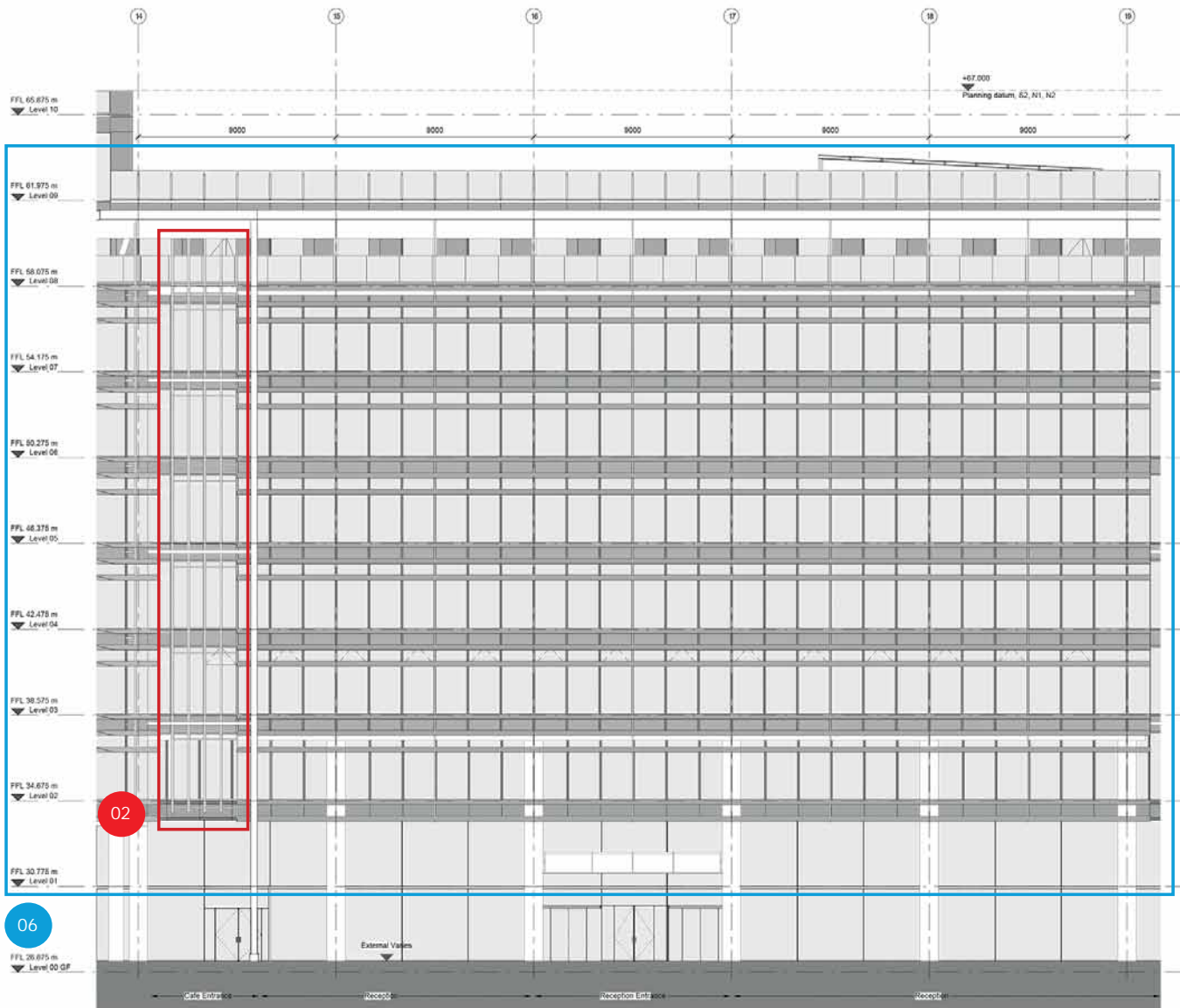

East Elevation N1

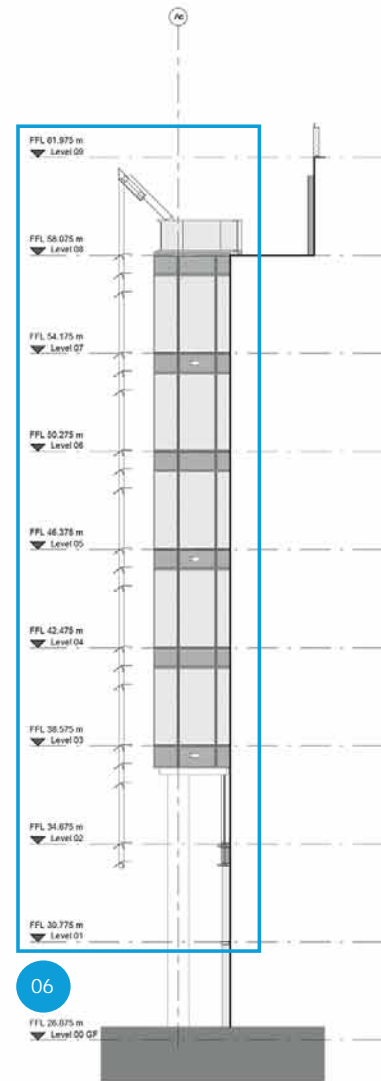

North Return Elev. N1

- 01. Change of use from D1 to B1 in Building T2 and from flexible B1 to A1-A4/ B1/D1/D2 in Building T3, at ground floor, with subsequent reconfiguration of those spaces.
- 02. Replacement of vertical brise-soleil with horizontal brise-soleil.
- 03. Amendments to roof levels.
- 04. Introduction of lift at Levels 0-3.
- 05. Reconfiguration of cycle changing rooms at Level 1.
- 06. Finished floor levels, structural slab levels and spandrel heights amended.
- 07. Atria enclosure removed.



**BENNETTS ASSOCIATES**

1 Rouseburn Place, London EC1V 7PL  
 T +44(0)20 73203333 - www.bennettsassociates.com  
 E mail@bennettsassociates.com

For further detailed technical information visit:  
[www.bennettsassociates.com/technical](http://www.bennettsassociates.com/technical)

Project 1503

Site **T2 KXC**  
 Kings Cross Central Partnership Ltd.

Drawing Title  
 East Elevation - Block N1

Block N1

Drawing Number  
 KXC-T2-001-A-1503-P20-322

Revision/Subsity  
 01

Scale @ A3  
 1 : 200

Scale @ A1  
 1 : 100

Revision Date  
 16/4/15

YVMS/D



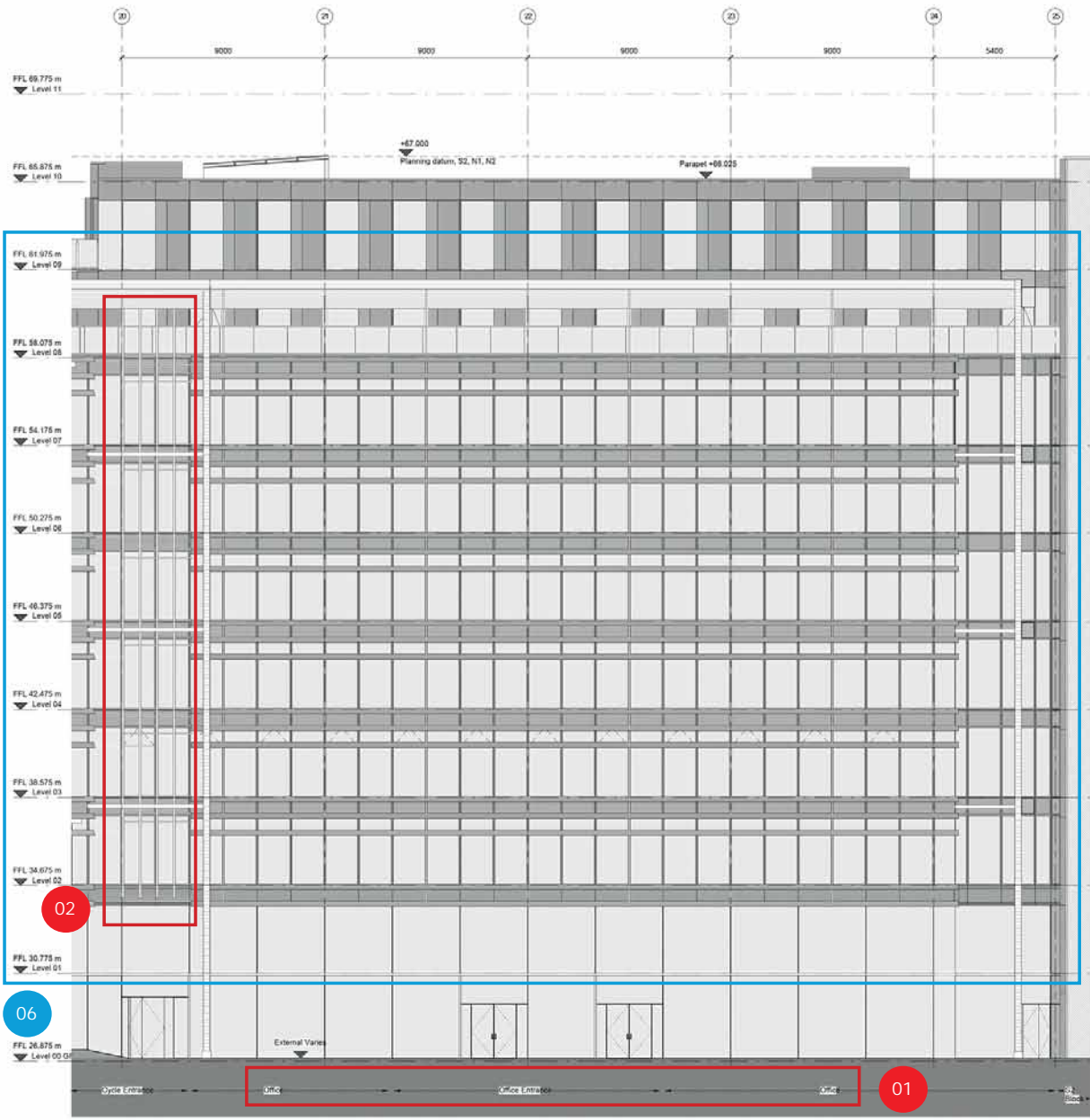

East Elevation N2

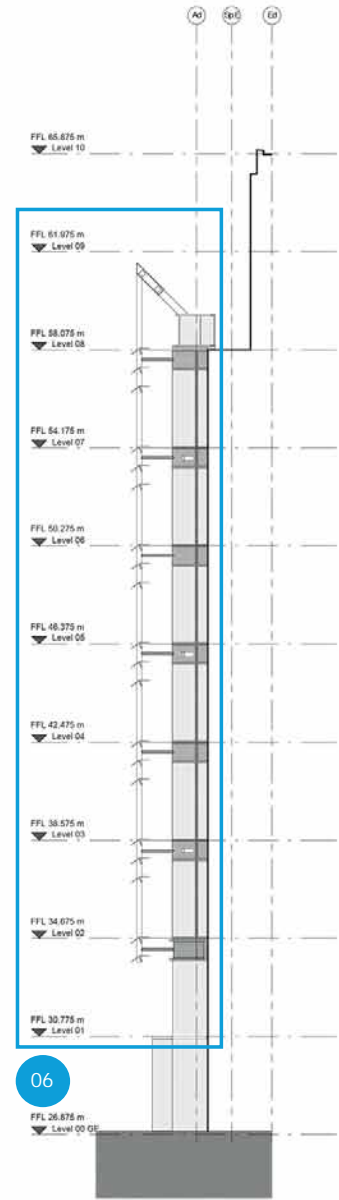

1503-20-323 - North Return Elev. N2

01. Change of use from D1 to B1 in Building T2 and from flexible B1 to A1-A4/B1/D1/D2 in Building T3, at ground floor, with subsequent reconfiguration of those spaces.
02. Replacement of vertical brise-soleil with horizontal brise-soleil.
03. Amendments to roof levels.
04. Introduction of lift at Levels 0-3.
05. Reconfiguration of cycle changing rooms at Level 1.
06. Finished floor levels, structural slab levels and spandrel heights amended.
07. Atria enclosure removed.



**BENNETTS ASSOCIATES**

1 Rousebone Place, London EC1V 7PL  
 T +44(0)20 73203203 • www.bennettsassociates.com  
 E mail@bennettsassociates.com

Project Site T2 KXC  
 Kings Cross Central Partnership Ltd.

Drawing Title  
 East Elevation - Block N2

Block N2

Drawing Number  
 KXC-T2-001-A-1503-P20-323

Revision/Subsity  
 01

Scale @ A3  
 1 : 200

Scale @ A1  
 1 : 100

Revision Date  
 16/4/15

YVMS/D



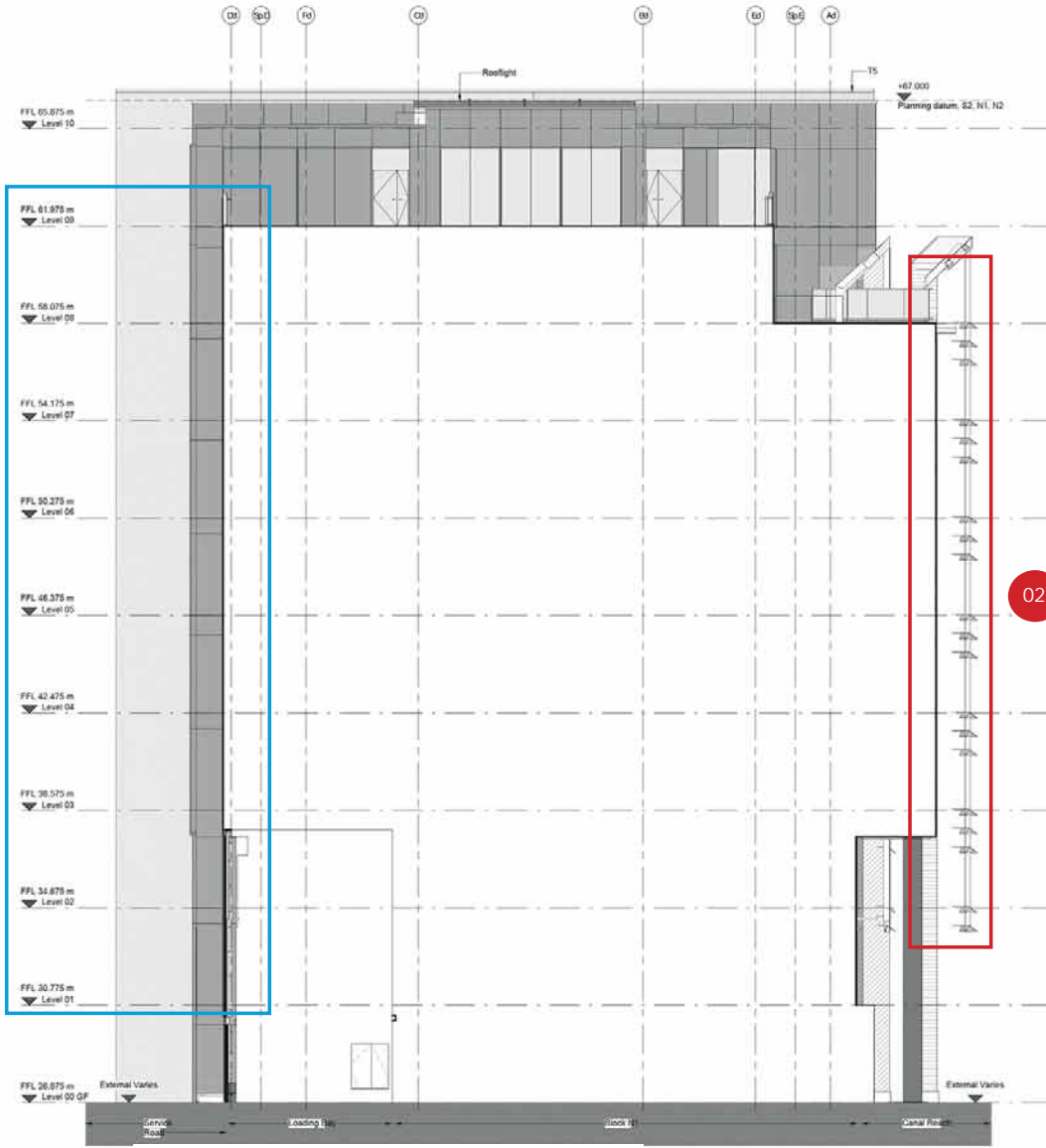

06

02

South Elevation N2

- 01. Change of use from D1 to B1 in Building T2 and from flexible B1 to A1-A4/B1/D1/D2 in Building T3, at ground floor, with subsequent reconfiguration of those spaces.
- 02. Replacement of vertical brise-soleil with horizontal brise-soleil.
- 03. Amendments to roof levels.
- 04. Introduction of lift at Levels 0-3.
- 05. Reconfiguration of cycle changing rooms at Level 1.
- 06. Finished floor levels, structural slab levels and spandrel heights amended.
- 07. Atria enclosure removed.



**BENNETTS ASSOCIATES**

1 Rousebone Place, London EC1V 7PL  
 T +44(0)207 3202333 - www.bennettsassociates.com  
 E mail@bennettsassociates.com

Project Site T2 KXC  
 Kings Cross Central Partnership Ltd.

Drawing Title  
 South Elevation - Block N2  
 Block N2

Drawing Number  
 KXC-T2-001-A-1503-P20-330

Scale @ A3 1 : 200  
 Scale @ A1 1 : 100  
 Revision/Date  
 01 16/4/15

YVMS10









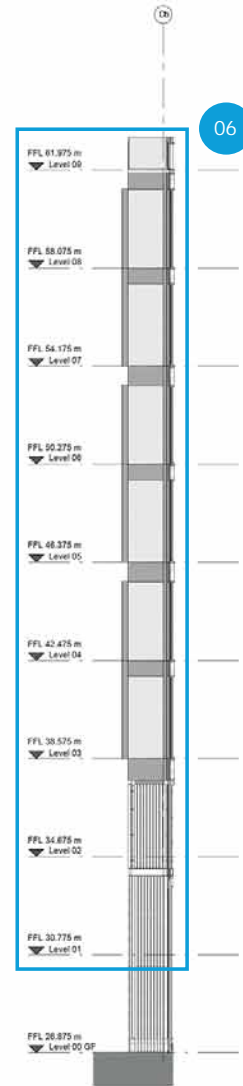
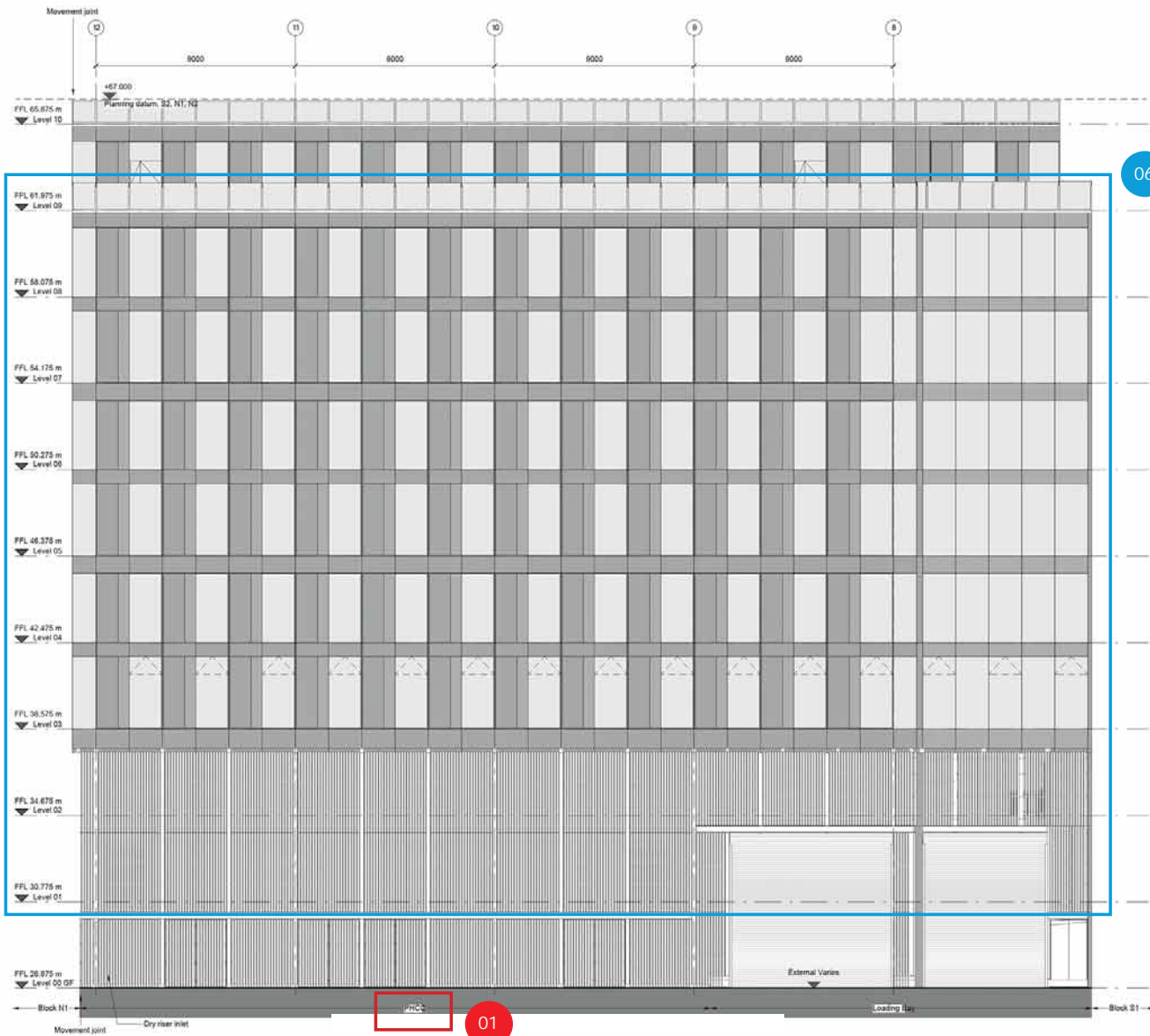

- 01. Change of use from D1 to B1 in Building T2 and from flexible B1 to A1-A4/B1/D1/D2 in Building T3, at ground floor, with subsequent reconfiguration of those spaces.
- 02. Replacement of vertical brise-soleil with horizontal brise-soleil.
- 03. Amendments to roof levels.
- 04. Introduction of lift at Levels 0-3.
- 05. Reconfiguration of cycle changing rooms at Level 1.
- 06. Finished floor levels, structural slab levels and spandrel heights amended.
- 07. Atria enclosure removed.



**BENNETTS ASSOCIATES**

1 Rouseburn Place, London EC1V 7PL  
 T +44(0)20 73203333 - www.bennettsassociates.com  
 E mail@bennettsassociates.com

Project Site T2 KXC  
 Kings Cross Central Partnership Ltd.

Drawing Title  
 West Elevation - Block S2  
 Block S2

Drawing Number  
 KXC-T2-001-A-1503-P20-341

Scale @ A3 Scale @ A1  
 1 : 100

Revision/Subtitle  
 01  
 Revision Date  
 16/4/15  
 YVMS/D



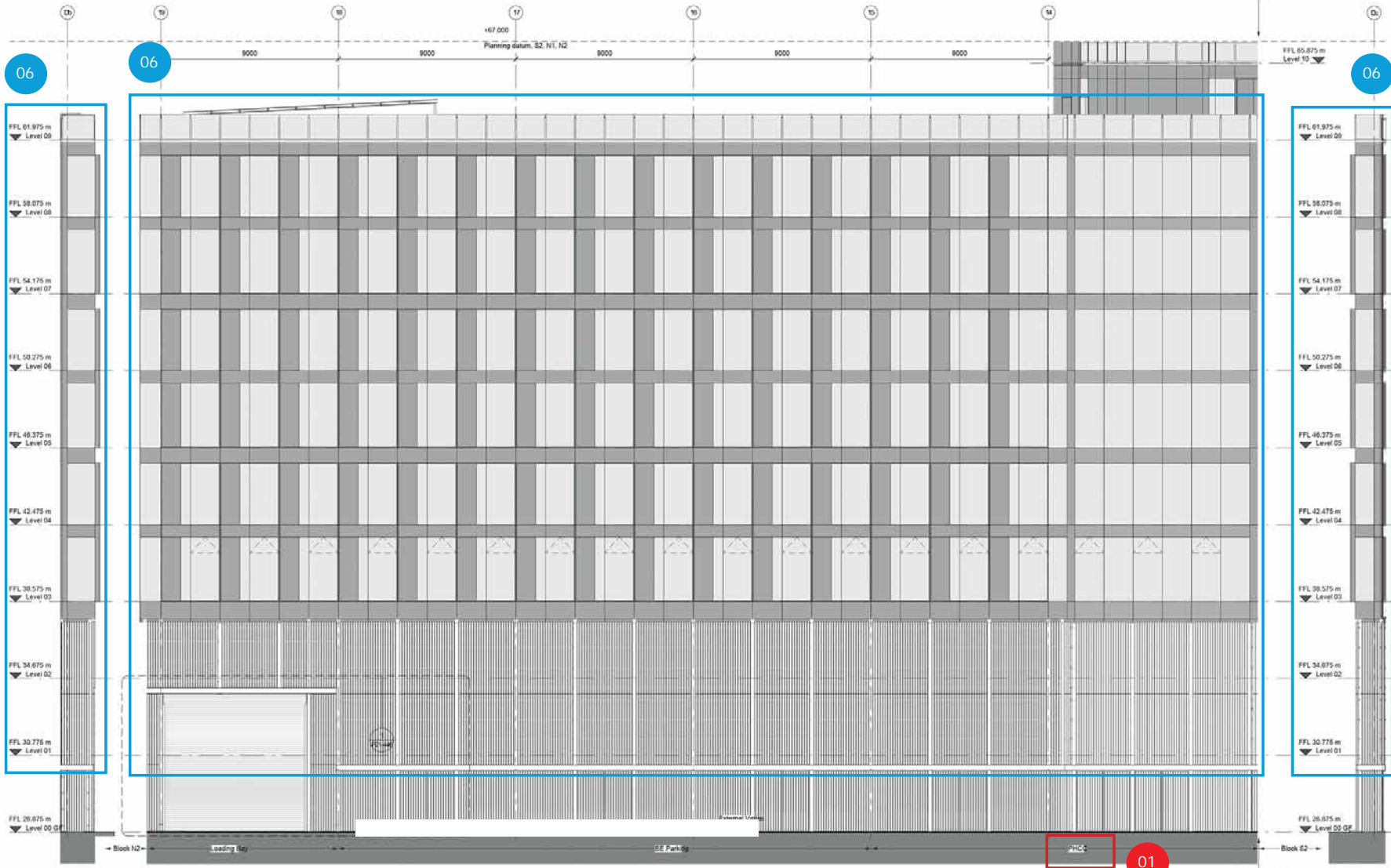

- 01. Change of use from D1 to B1 in Building T2 and from flexible B1 to A1-A4/ B1/D1/D2 in Building T3, at ground floor, with subsequent reconfiguration of those spaces.
- 02. Replacement of vertical brise-soleil with horizontal brise-soleil.
- 03. Amendments to roof levels.
- 04. Introduction of lift at Levels 0-3.
- 05. Reconfiguration of cycle changing rooms at Level 1.
- 06. Finished floor levels, structural slab levels and spandrel heights amended.
- 07. Atria enclosure removed.



**BENNETTS ASSOCIATES**

1 Renshorne Place, London EC1V 7PL  
 T +44(0)207 6300333 - www.bennettsassociates.com  
 E mail@bennettsassociates.com

Project: Site T2 KXC  
 Kings Cross Central Partnership Ltd.

Drawing Title: West Elevation - Block N1  
 Block N1

Drawing Number: KXC-T2-001-A-1503-P20-342  
 Revision/Subsity: 01  
 Scale @ A3: 1:100  
 Revision Date: 16/4/15  
 VVMS/D

North Return Elev. S2 West Elevation N1

South Return Elev. N2

01



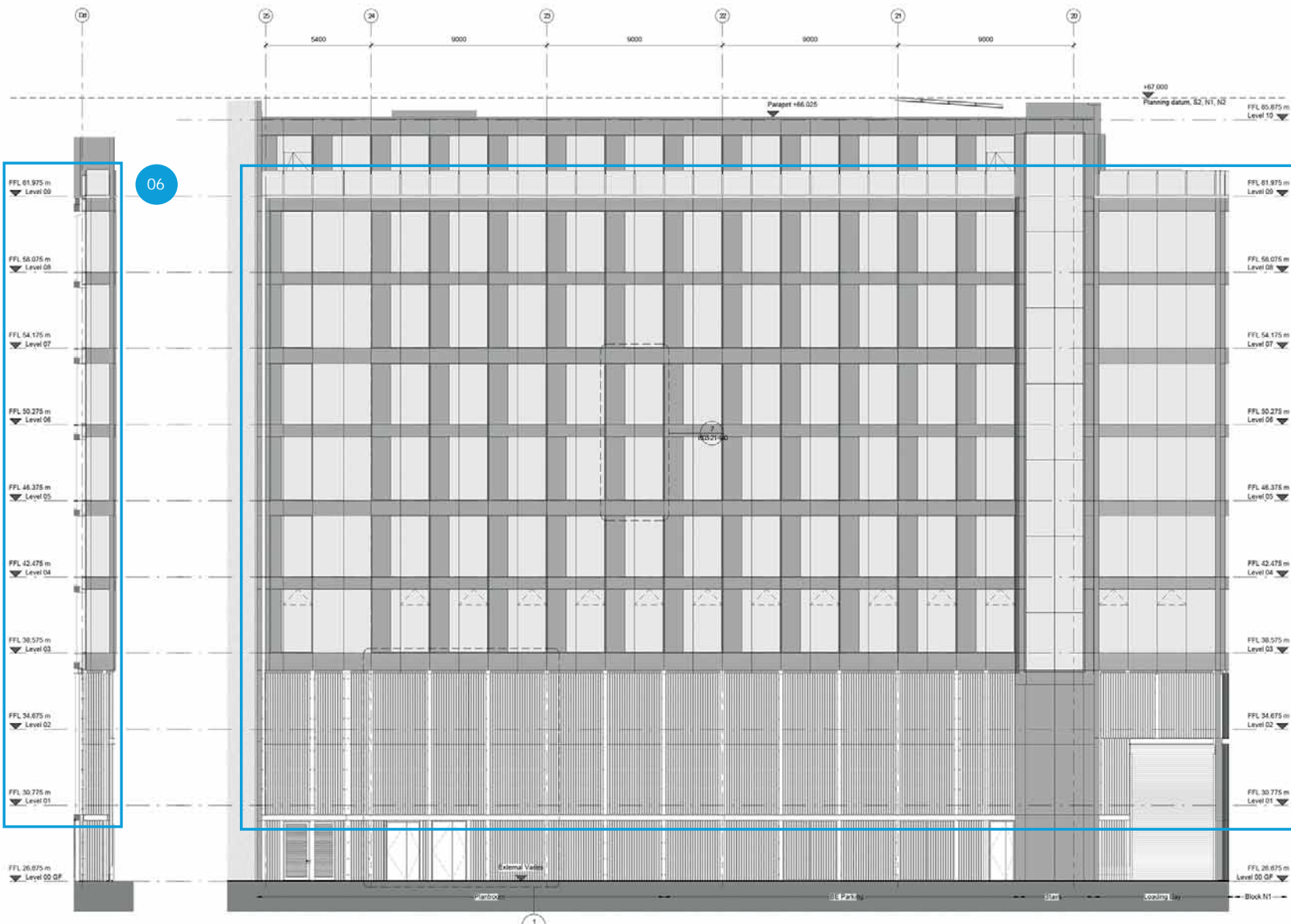

North Return Elev. N2

West Elevation N2

- 01. Change of use from D1 to B1 in Building T2 and from flexible B1 to A1-A4/ B1/D1/D2 in Building T3, at ground floor, with subsequent reconfiguration of those spaces.
- 02. Replacement of vertical brise-soleil with horizontal brise-soleil.
- 03. Amendments to roof levels.
- 04. Introduction of lift at Levels 0-3.
- 05. Reconfiguration of cycle changing rooms at Level 1.
- 06. Finished floor levels, structural slab levels and spandrel heights amended.
- 07. Atria enclosure removed.



**BENNETTS ASSOCIATES**

1 Ravelston Place, London EC1V 7PL  
 T +44(0)207 6300333 | www.bennettsassociates.com  
 E mail@bennettsassociates.com

Project Site T2 KXC  
 Kings Cross Central Partnership Ltd.

Drawing Title  
 West Elevation - Block N2

Block N2

Drawing Number  
 KXC-T2-001-A-1503-P20-343

Revision/Subsity  
 01

Scale @ A3  
 1 : 100

Revision Date  
 16/4/15

YVMS/D



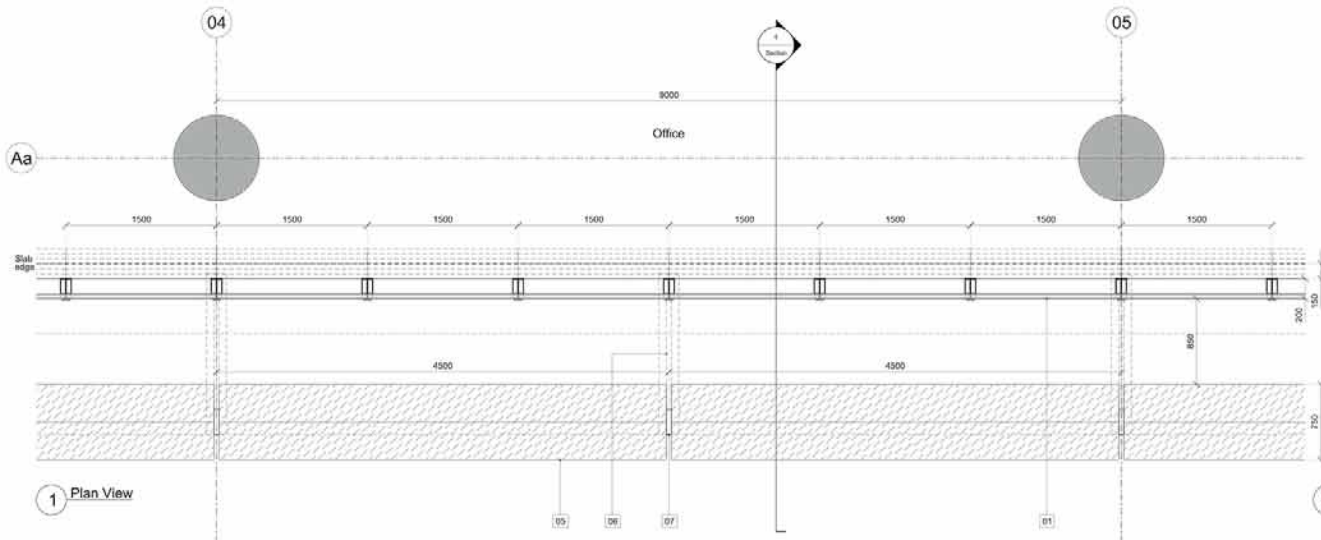

1 Plan View



3 Axo View

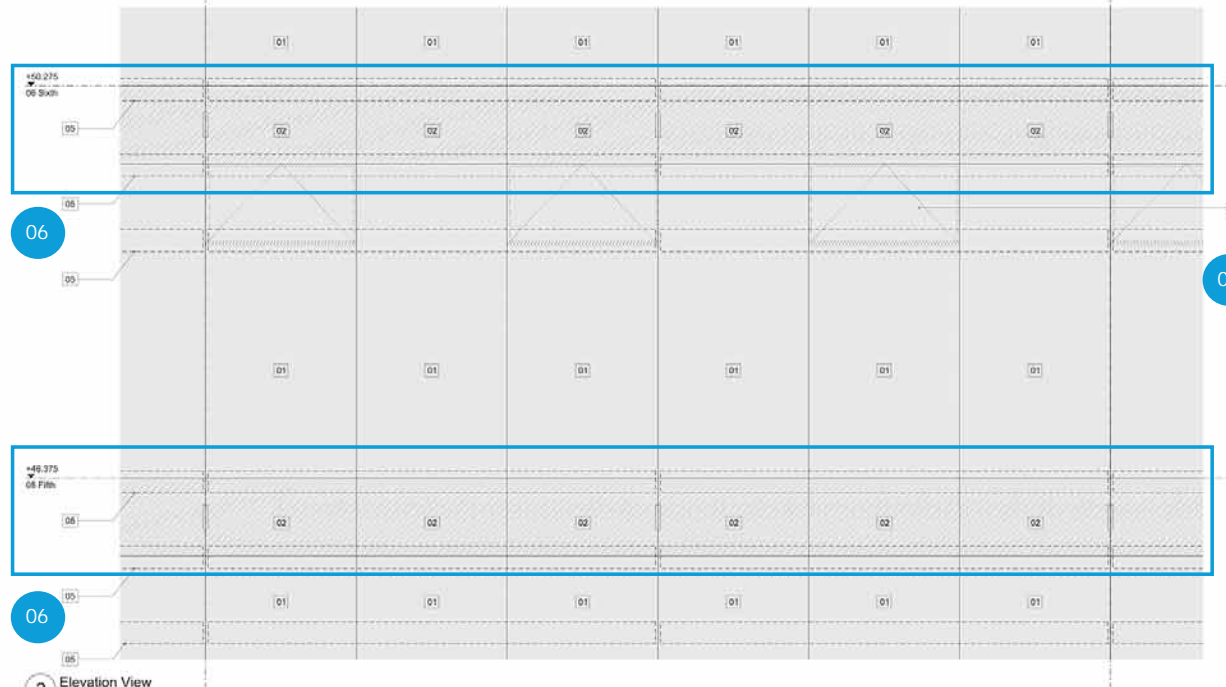

2 Elevation View

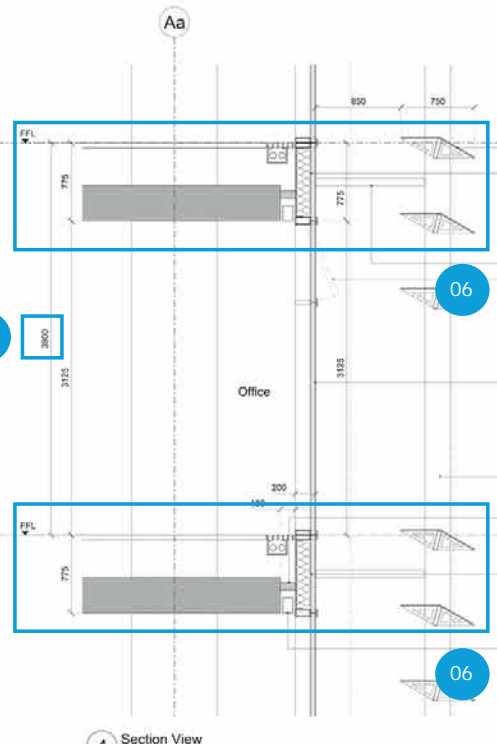

4 Section View

- 01. Change of use from D1 to B1 in Building T2 and from flexible B1 to A1-A4/ B1/D1/D2 in Building T3, at ground floor, with subsequent reconfiguration of those spaces.
- 02. Replacement of vertical brise-soleil with horizontal brise-soleil.
- 03. Amendments to roof levels.
- 04. Introduction of lift at Levels 0-3.
- 05. Reconfiguration of cycle changing rooms at Level 1.
- 06. Finished floor levels, structural slab levels and spandrel heights amended.
- 07. Atria enclosure removed.

0 1m



**BENNETTS ASSOCIATES**  
 1 Ravelston Place, London EC1V 7NL  
 T +44(0)20 7 5222200 • www.bennettsassociates.com  
 E info@bennettsassociates.com

Project No. 1503  
**Site T2 KXC**  
 Kings Cross Central Partnership Ltd.  
 Drawing Title  
**Façade Bay Study**  
 East Elevation  
 Typical Office Floor with Louvers

Drawing Number: KXC-T2-001-A-1503-P21-420 01  
 Revision/Suitability  
 Scale @ A3: 1 : 50  
 Scale @ A1: 1 : 25  
 Revision Date: 160415  
 YY MM DD





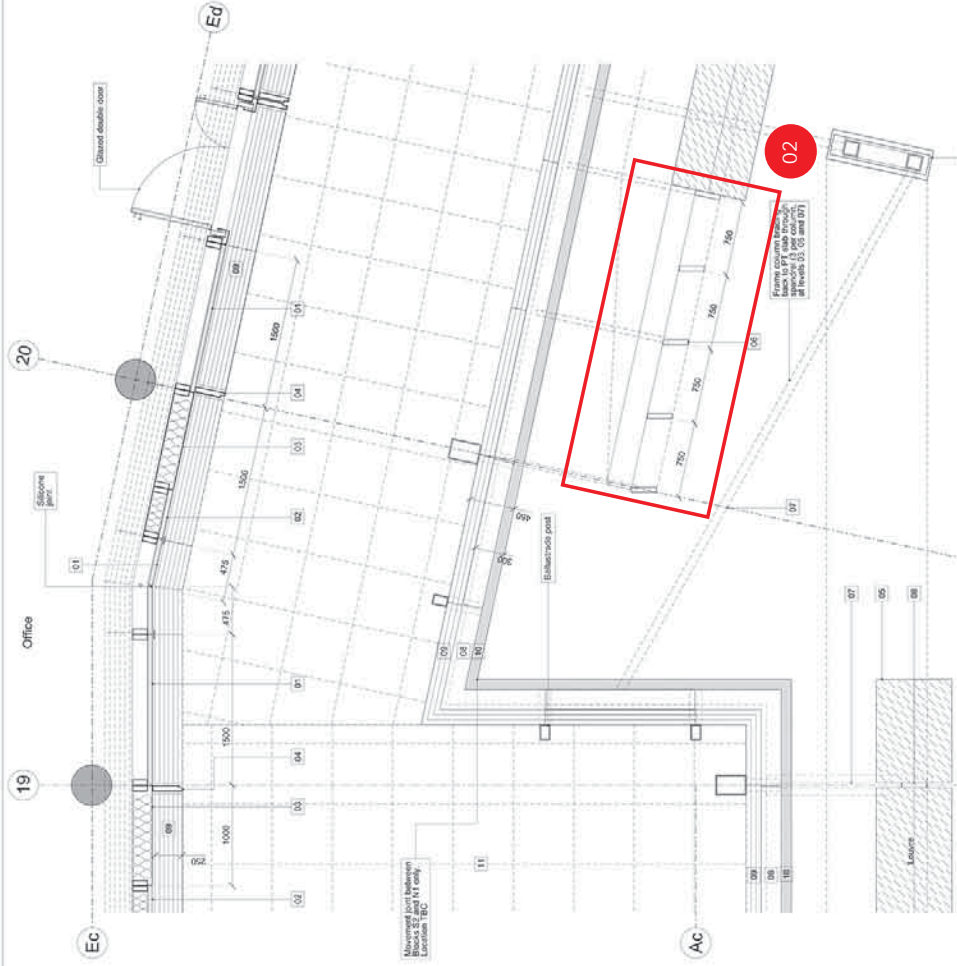

1 Plan View Level 08\_Terrace

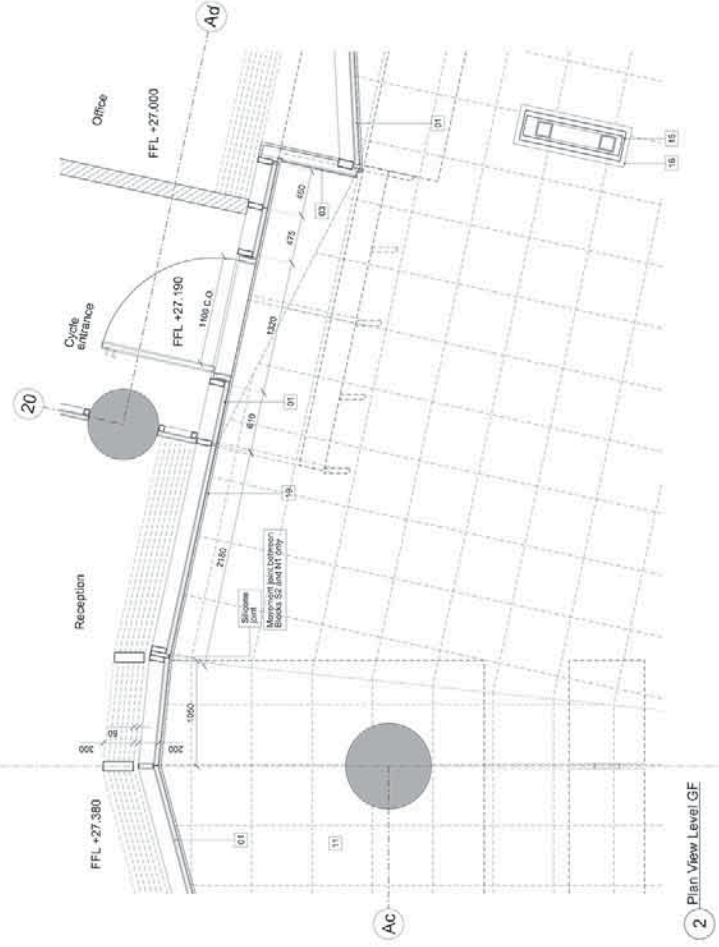

2 Plan View Level GF

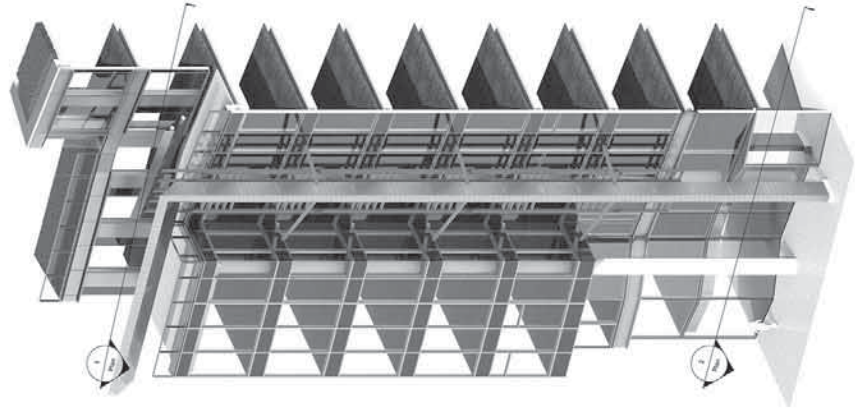

3 Axo View N1 Return (without busses for visual purposes)

- 01. Change of use from D1 to B1 in Building T2 and from flexible B1 to A1-A4/B1/D1/D2 in Building T3, at ground floor, with subsequent reconfiguration of those spaces.
- 02. Replacement of vertical brise-soleil with horizontal brise-soleil.
- 03. Amendments to roof levels.
- 04. Introduction of lift at Levels 0-3.
- 05. Reconfiguration of cycle changing rooms at Level 1.
- 06. Finished floor levels, structural slab levels and spandrel heights amended.
- 07. Atria enclosure removed.

**BENNETTS ASSOCIATES**

1 Benetton Place, London EC1Y 7NL  
 T +44(0)207 6205555 • www.bennettsassociates.com  
 info@bennettsassociates.com

Project  
**Site T2 KXC**  
 King's Cross Central Partnership Ltd.

Drawing Title  
**Facade Bay Study**  
 East Elevation  
 Knuckle  
 Blocks N1 and N2

Project No. 1509  
 Drawing Number  
 KXC-T2-001-A-1503-P21-421\_01  
 Scale @ A3  
 1:50  
 Scale @ A1  
 1:25  
 Revision Date  
 16/04/15  
 Revision No.  
 01



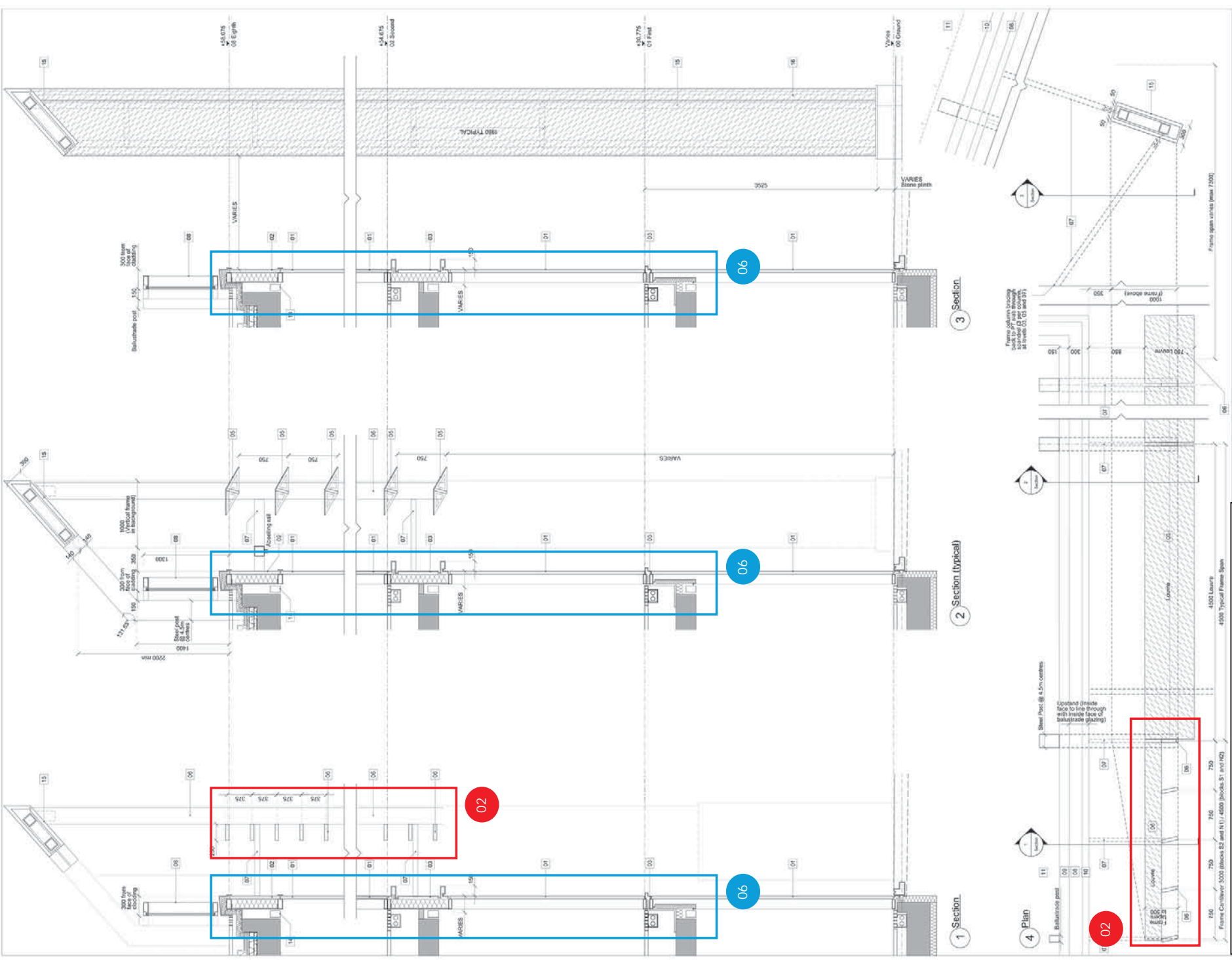

**Project** Site T2 KXC  
 Kings Cross Central Partnership Ltd.

**Project No.** 1501

**Drawing Number** KXC-T2-001-A-1503-P21-422\_01

**Revision/Quality**

**Scale @ A3** Scale @A1 1:50 1:25

**Revision Date** 16/04/15

**Revision** 01

**Project Title** Facede Bay Study  
 East Elevation  
 Screen and Frame

**Revisions**

**01.** Change of use from D1 to B1 in Building T2 and from flexible B1 to A1-A4/B1/D1/D2 in Building T3, at ground floor, with subsequent reconfiguration of those spaces.

**02.** Replacement of vertical brise-soleil with horizontal brise-soleil.

**03.** Amendments to roof levels.

**04.** Introduction of lift at Levels 0-3.

**05.** Reconfiguration of cycle changing rooms at Level 1.

**06.** Finished floor levels, structural slab levels and spandrel heights amended.

**07.** Atria enclosure removed.

**BENNETTS ASSOCIATES**  
 1 Beaufort Place, London EC1A 1BE  
 T +44(0)20 7323 2500 www.bennettsassociates.com



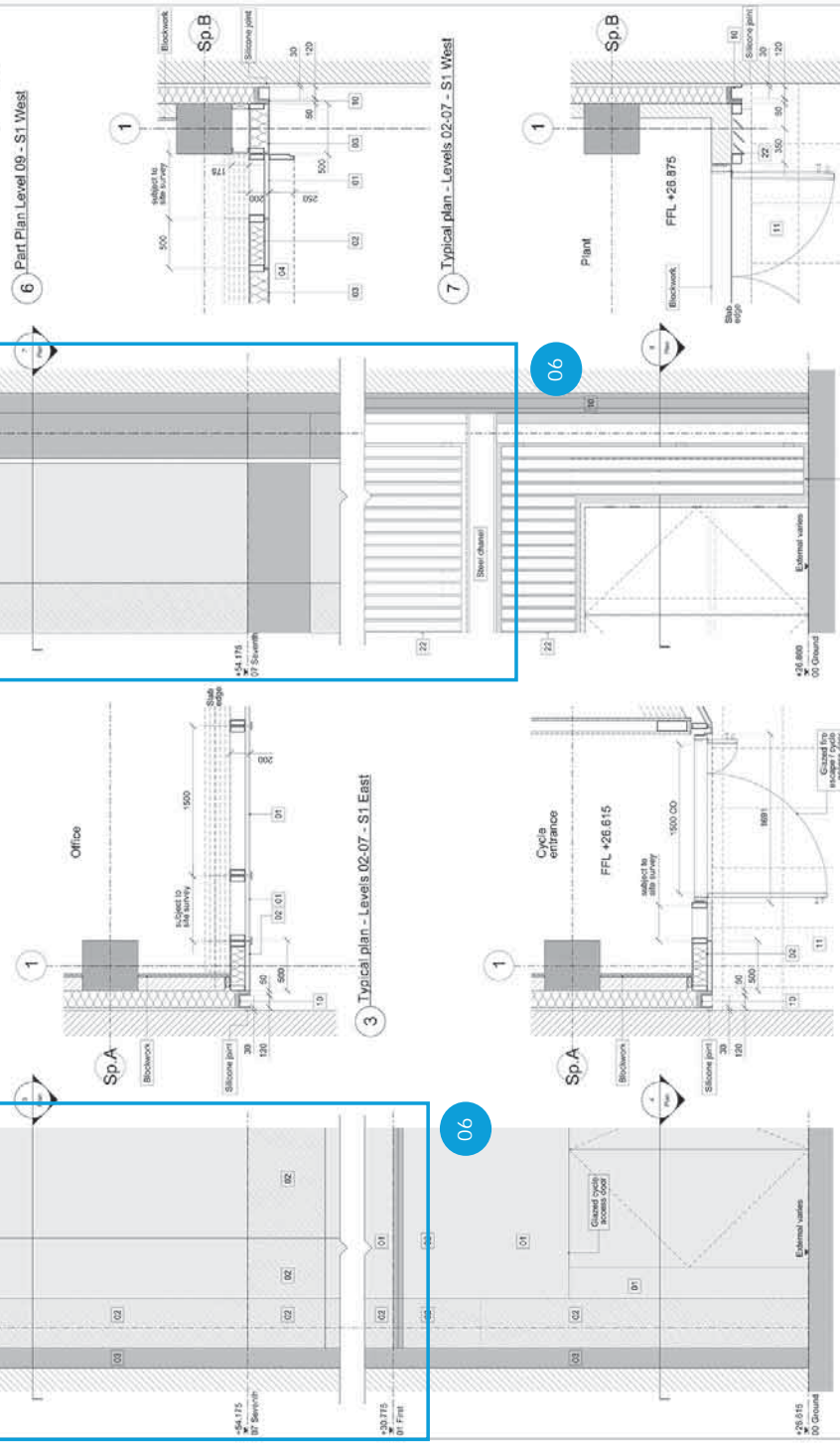
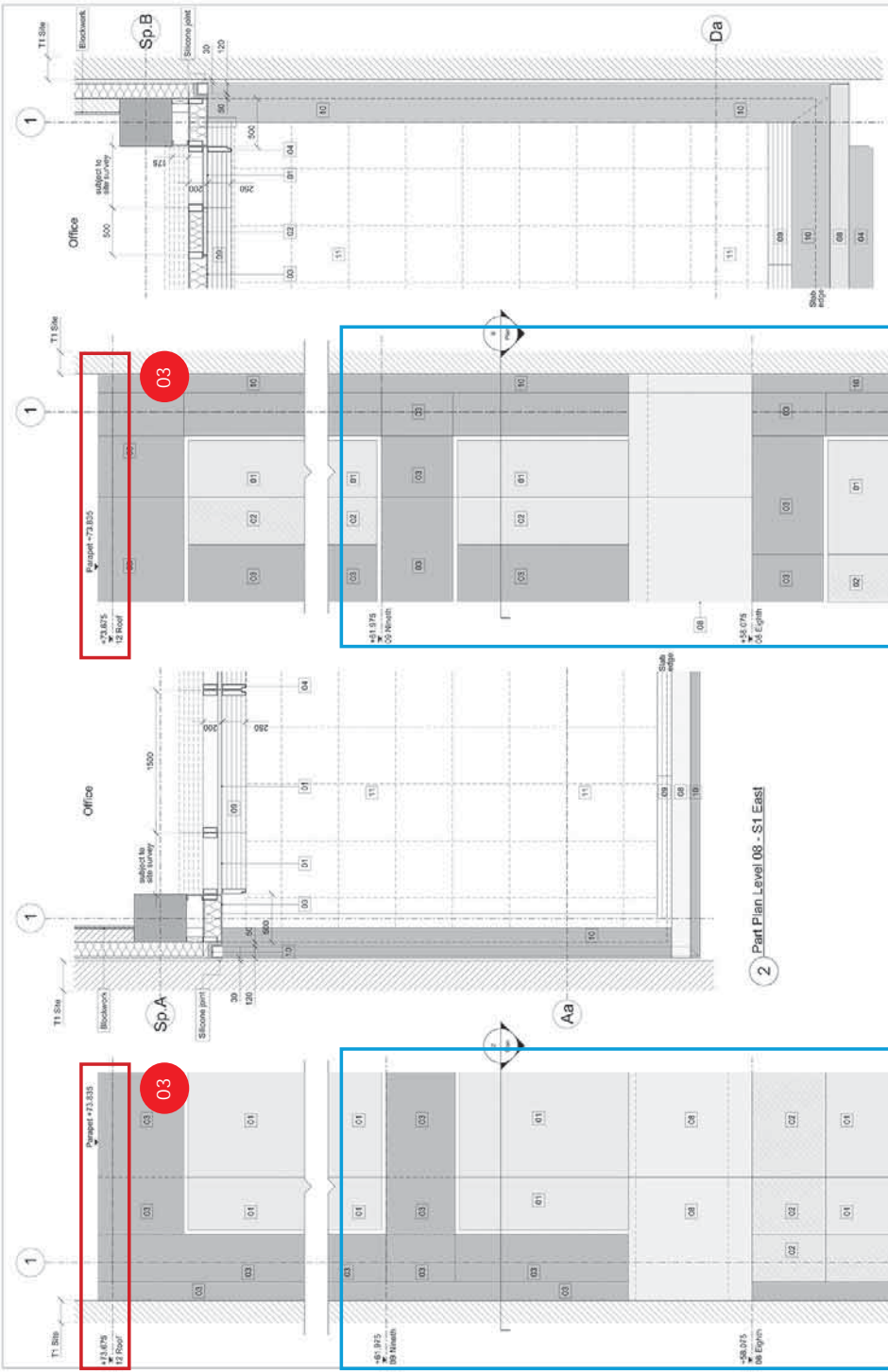

**1** South Party Wall - S1 East Elevation View

**2** Part Plan Level 08 - S1 East

**3** Typical plan - Levels 02-07 - S1 East

**4** Part Plan Level 08 - S1 East

**5** South Party Wall - S1 West Elevation View

**6** Part Plan Level 09 - S1 West

**7** Typical plan - Levels 02-07 - S1 West

**8** Part Plan Level 09 - S1 West

**01.** Change of use from D1 to B1 in Building T2 and from flexible B1 to A1-A4/B1/D1/D2 in Building T3, at ground floor, with subsequent reconfiguration of those spaces.

**02.** Replacement of vertical brise-soleil with horizontal brise-soleil.

**03.** Amendments to roof levels.

**04.** Introduction of lift at Levels 0-3.

**05.** Reconfiguration of cycle changing rooms at Level 1.

**06.** Finished floor levels, structural slab levels and spandrel heights amended.

**07.** Atria enclosure removed.

**Project** Site T2 KXC  
Kings Cross Central Partnership Ltd.

**Drawing Title** Facade Bay Study  
East + West Elevation  
Party Wall South

**Revision Number** KXC-T2-001-AA-1903-P21-423\_01

**Scale @ A3** Scale @A1  
1:50 1:25

**Revision Date** 16/04/15

**Project No.** 1503

**Revision/Subsity**

**BENNETTS ASSOCIATES**  
1 Newcombe Place, London EC1Y 7NL  
T +44(0)207 5205555 • www.bennettsassociates.com



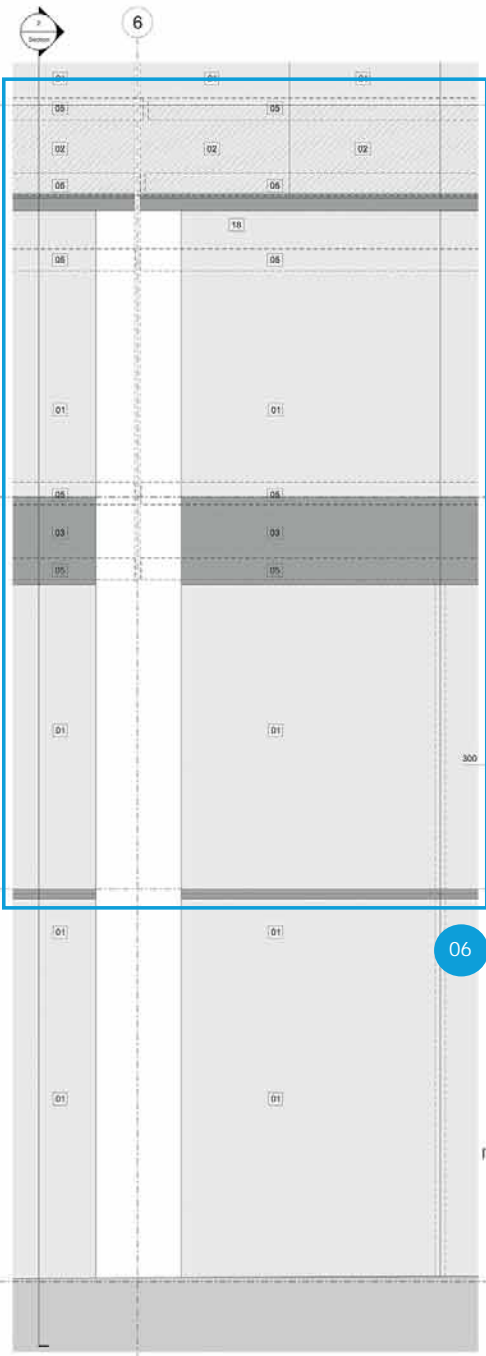

1 Elevation View

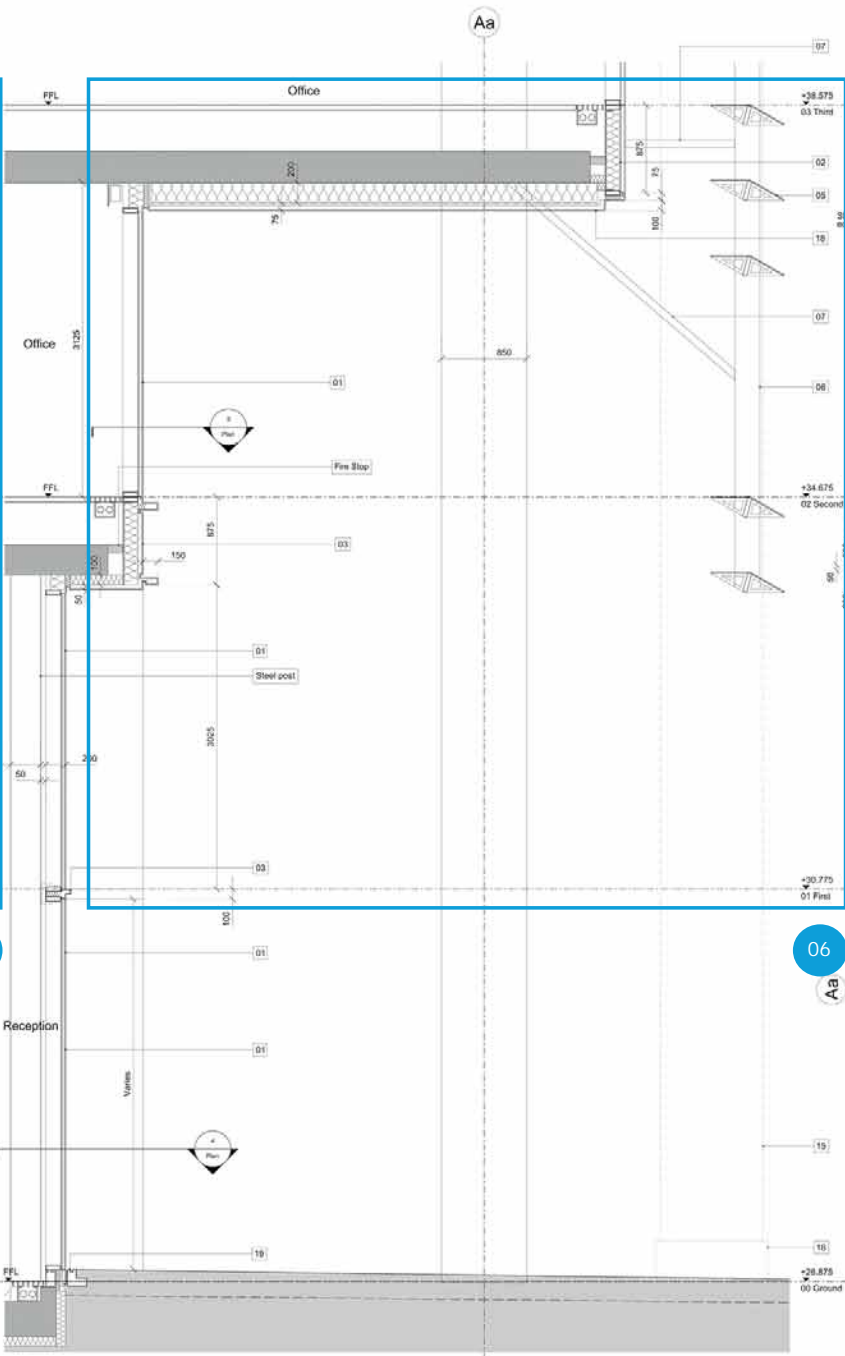

2 Section View

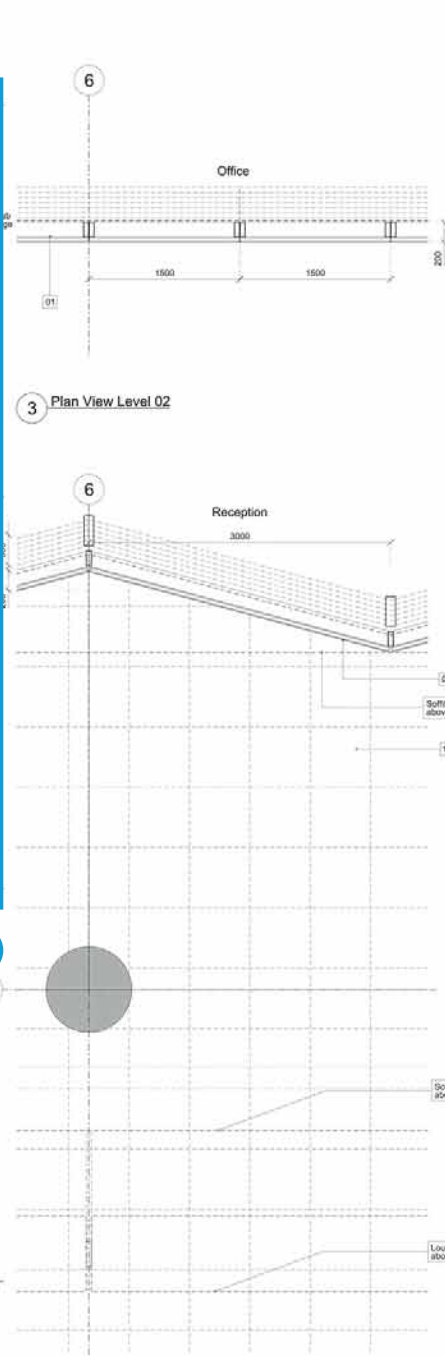

4 Plan View Level GF

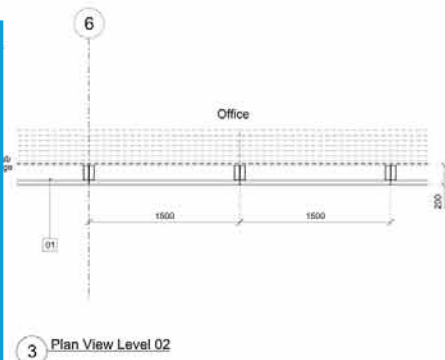

3 Plan View Level 02

- 01. Change of use from D1 to B1 in Building T2 and from flexible B1 to A1-A4/B1/D1/D2 in Building T3, at ground floor, with subsequent reconfiguration of those spaces.
- 02. Replacement of vertical brise-soleil with horizontal brise-soleil.
- 03. Amendments to roof levels.
- 04. Introduction of lift at Levels 0-3.
- 05. Reconfiguration of cycle changing rooms at Level 1.
- 06. Finished floor levels, structural slab levels and spandrel heights amended.
- 07. Atria enclosure removed.

01 Structural steel  
02 Architectural steel  
03 Glass curtain wall system (Gensler, B&B, T&C)

0 1m



## BENNETTS ASSOCIATES

1 Ravenhoe Place, London EC1V 7JG  
T +44(0)20 7512 2200 • www.bennettsassociates.com  
E info@bennettsassociates.com

For Bennett's Associates information on our services please visit our website: www.bennettsassociates.com

Project Kings Cross Central Partnership Ltd. Project No. 1503

Drawing Title  
**Façade Bay Study**  
East Elevation  
Three Storey Colonnade

Drawing Number  
KXC-T2-001-A-1503-P21-424 01

Scale @ A3 1:50  
Scale @ A1 1:25  
Revision Date 160415  
BY MM 00





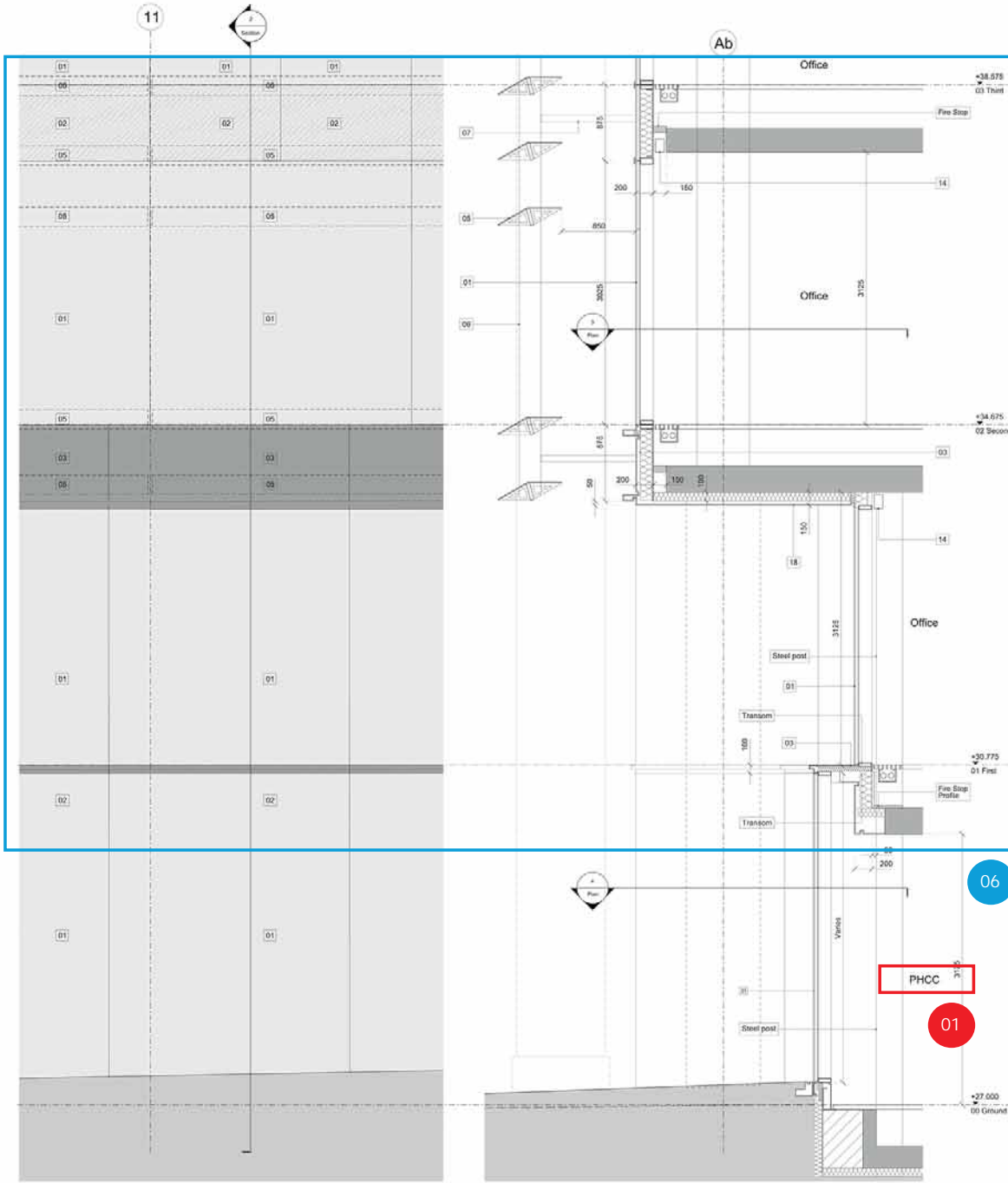

1 Elevation View

2 Section View

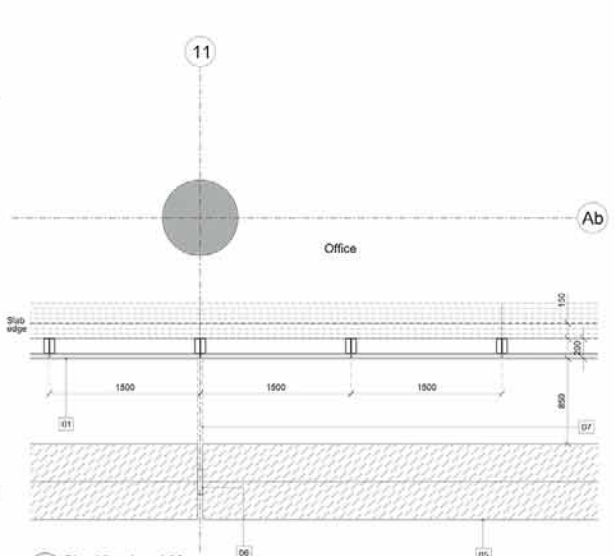

3 Plan View Level 02

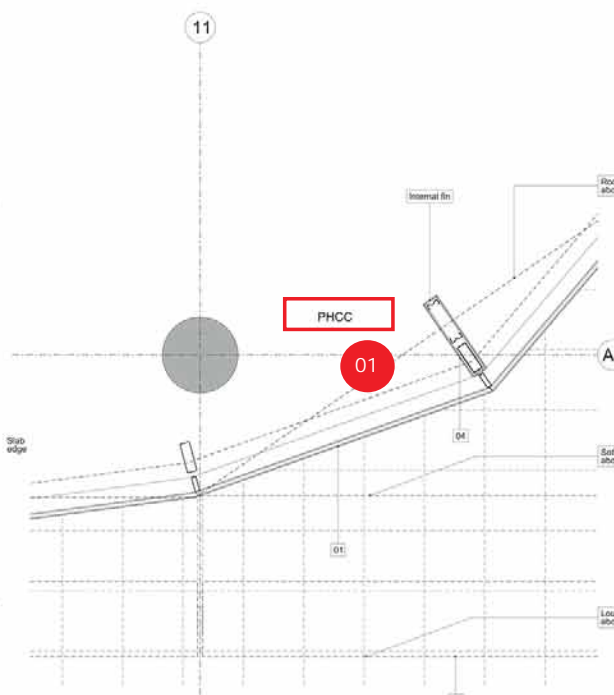

4 Plan View Level GF and 01

- 01. Change of use from D1 to B1 in Building T2 and from flexible B1 to A1-A4/B1/D1/D2 in Building T3, at ground floor, with subsequent reconfiguration of those spaces.
- 02. Replacement of vertical brise-soleil with horizontal brise-soleil.
- 03. Amendments to roof levels.
- 04. Introduction of lift at Levels 0-3.
- 05. Reconfiguration of cycle changing rooms at Level 1.
- 06. Finished floor levels, structural slab levels and spandrel heights amended.
- 07. Atria enclosure removed.

01. Section  
02. Section  
03. Section  
04. Section  
05. Section  
06. Section  
07. Section

0 1m

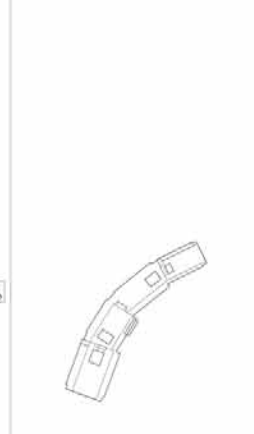

**BENNETTS ASSOCIATES**  
 1 Ravenstone Place, London EC1V 7NL  
 T +44(0)20 7 5222209 • www.bennettsassociates.com  
 E info@bennettsassociates.com

Project No. 1503  
**Site T2 KXC**  
 Kings Cross Central Partnership Ltd.

Drawing Title  
**Façade Bay Study**  
 East Elevation  
 Two Storey Colonnade

Drawing Number  
**KXC-T2-001-A-1503-P21-425 01**

Revision/Suitability  
 Revision Date  
 160415  
 YY MM DD



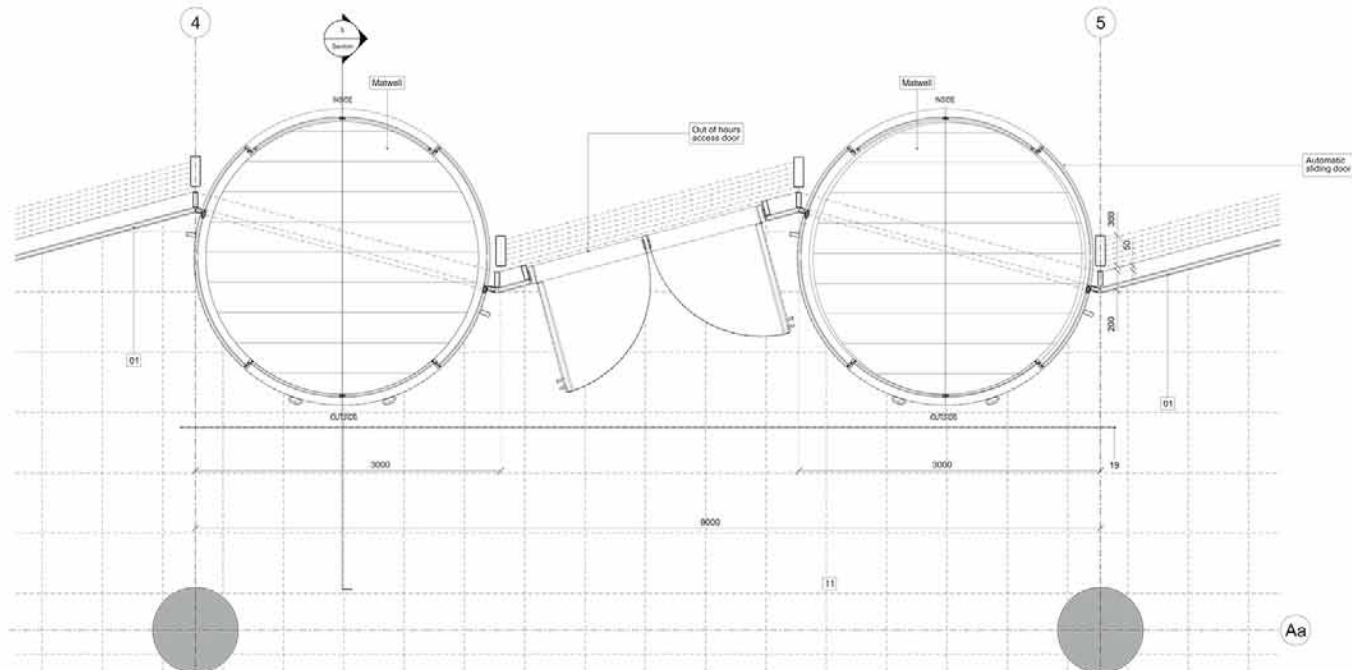

1 Plan View

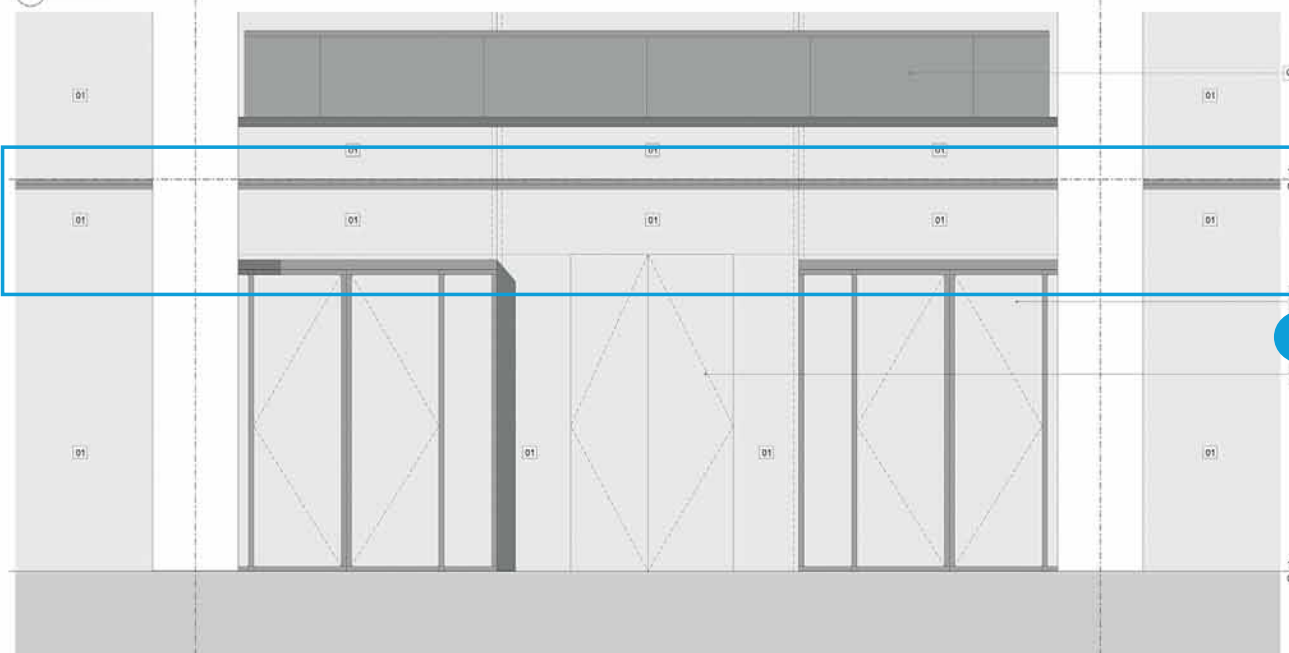

2 Elevation View

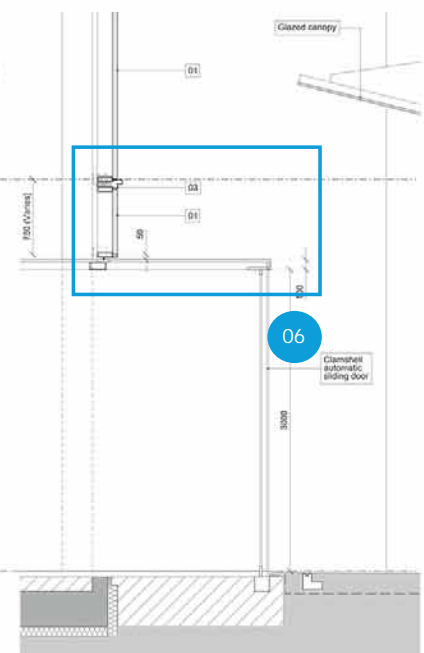

3 Section View

- 01. Change of use from D1 to B1 in Building T2 and from flexible B1 to A1-A4/B1/D1/D2 in Building T3, at ground floor, with subsequent reconfiguration of those spaces.
- 02. Replacement of vertical brise-soleil with horizontal brise-soleil.
- 03. Amendments to roof levels.
- 04. Introduction of lift at Levels 0-3.
- 05. Reconfiguration of cycle changing rooms at Level 1.
- 06. Finished floor levels, structural slab levels and spandrel heights amended.
- 07. Atria enclosure removed.

0 1m



**BENNETTS ASSOCIATES**  
 1 Ravelston Place, London EC1V 7NL  
 T +44(0)20 7 5202209 • www.bennettsassociates.com  
 E info@bennettsassociates.com

Project No. 1503  
**Site T2 KXC**  
 Kings Cross Central Partnership Ltd.

Drawing Title  
**Façade Bay Study**  
 East Elevation  
 Reception Entrance

Drawing Number  
 KXC-T2-001-A-1503-P21-427 01

Scale @ A3 1 : 50  
 Scale @ A1 1 : 25  
 Revision Date 160415  
 YY MM DD



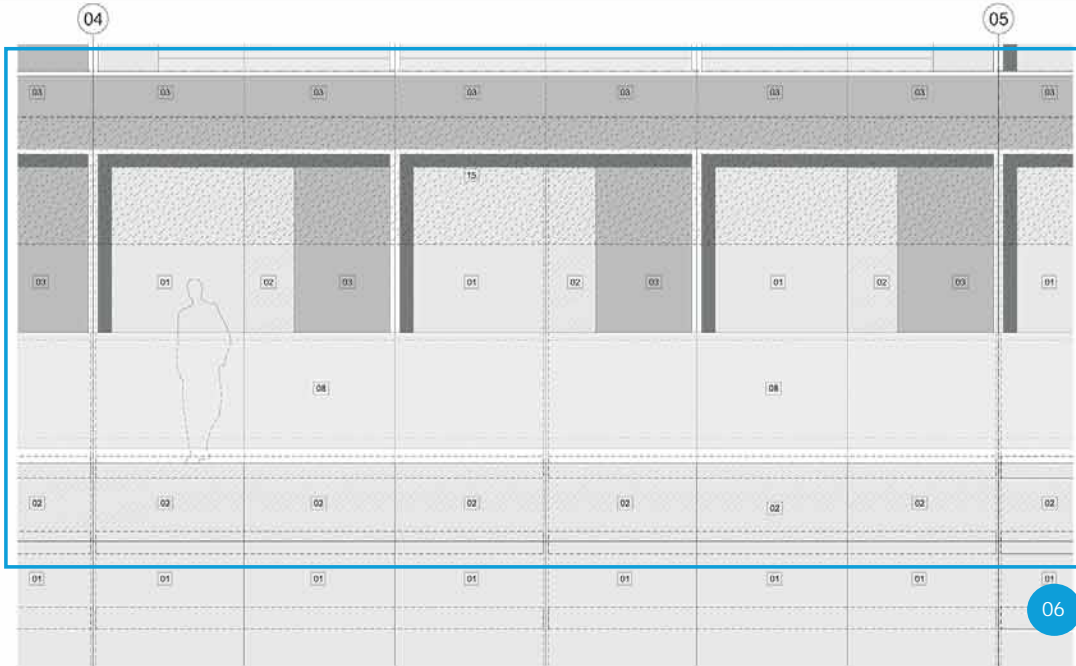

1 Elevation

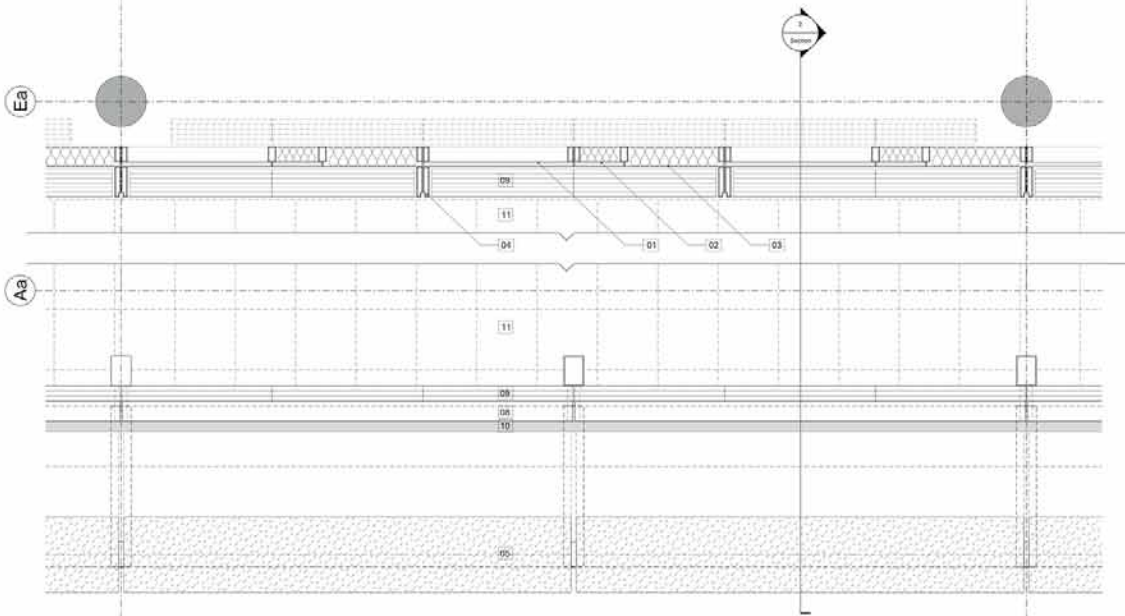

3 Plan Level 08

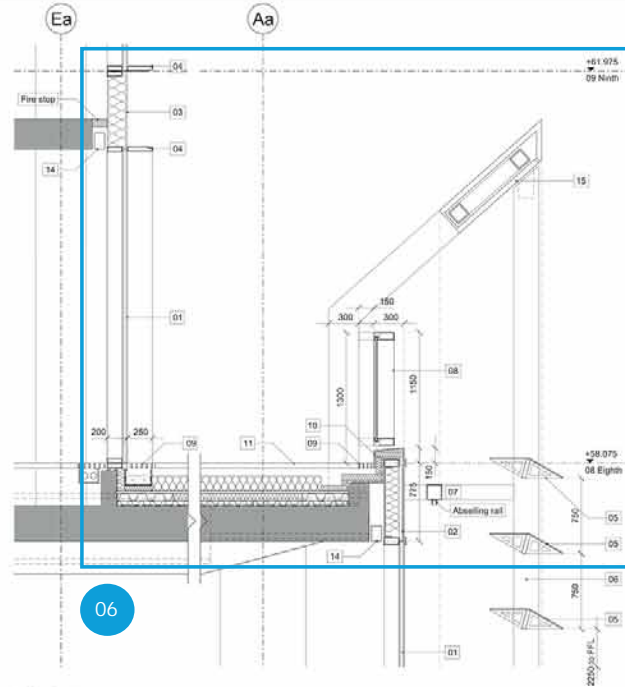

2 Section

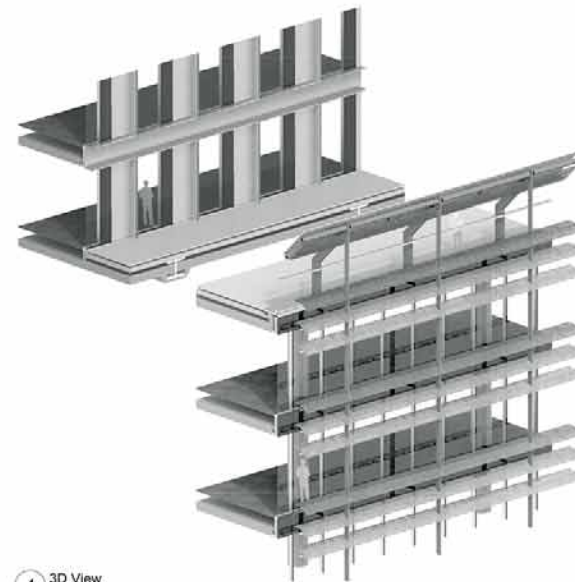

4 3D View

- 01. Change of use from D1 to B1 in Building T2 and from flexible B1 to A1-A4/B1/D1/D2 in Building T3, at ground floor, with subsequent reconfiguration of those spaces.
- 02. Replacement of vertical brise-soleil with horizontal brise-soleil.
- 03. Amendments to roof levels.
- 04. Introduction of lift at Levels 0-3.
- 05. Reconfiguration of cycle changing rooms at Level 1.
- 06. Finished floor levels, structural slab levels and spandrel heights amended.
- 07. Atria enclosure removed.

01. Vertical glass unit  
02. Architectural stone  
03. Horizontal glass unit  
04. Solid masonry (Concrete, BAL 130)



**BENNETTS ASSOCIATES**

1 Ravenhill Place, London EC1V 7JG  
T +44(0)207 5102200 • www.bennettsassociates.com  
E info@bennettsassociates.com

Project Project No. 1503

**Site T2 KXC**  
Kings Cross Central Partnership Ltd.

Drawing Title  
**Facade Bay Study**  
East Elevation  
Level 8 Terrace / Office Floor

Drawing Number Revision/Subsity  
KXC-T2-001-A-1503-P21-428 01

Scale @ A3 Scale @ A1 Revision Date  
1 : 50 1 : 25 160415  
VF MM 00





1 Elevation View

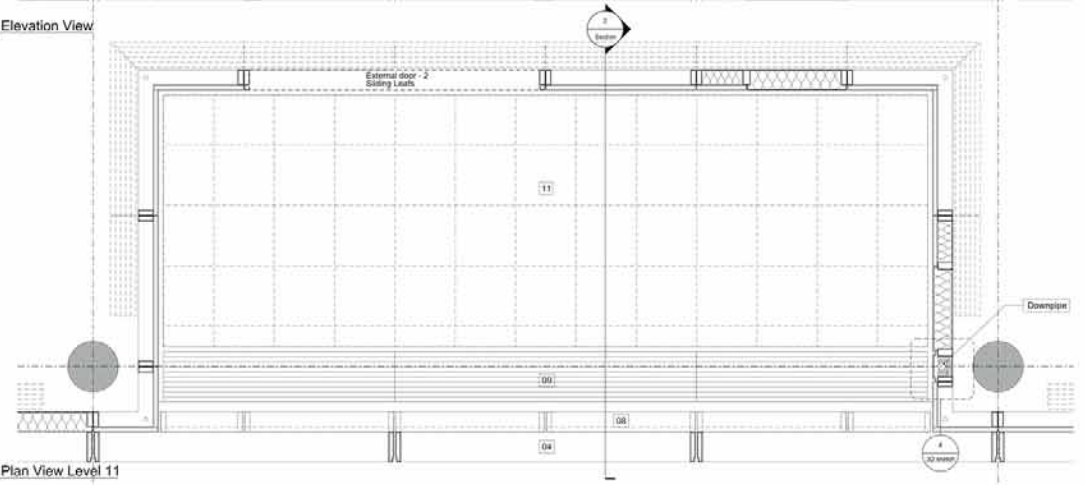

3 Plan View Level 11

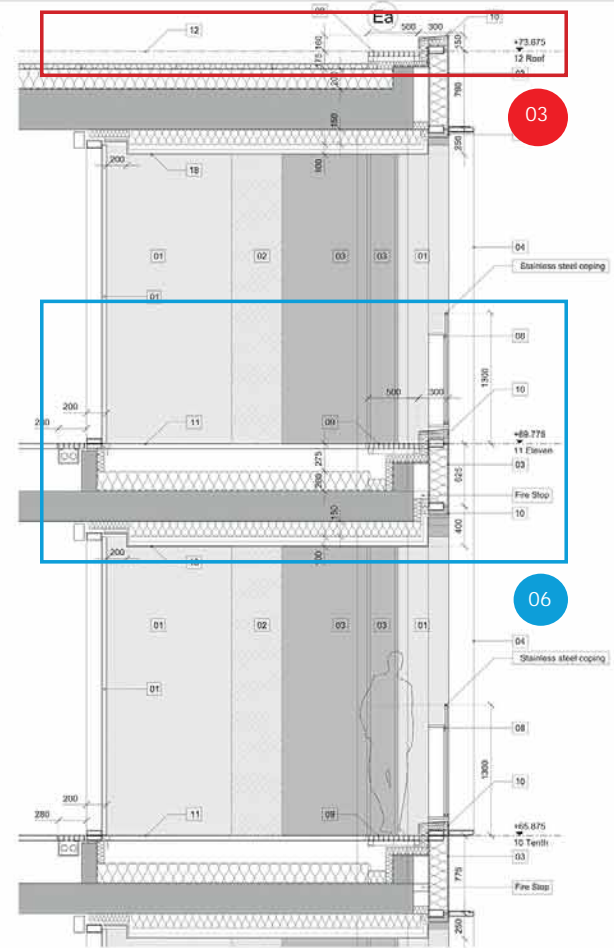

2 Section View

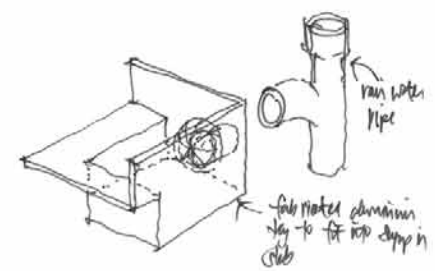

4 3D Sketch of RWP / Upstand Interface

- 01. Change of use from D1 to B1 in Building T2 and from flexible B1 to A1-A4/B1/D1/D2 in Building T3, at ground floor, with subsequent reconfiguration of those spaces.
- 02. Replacement of vertical brise-soleil with horizontal brise-soleil.
- 03. Amendments to roof levels.
- 04. Introduction of lift at Levels 0-3.
- 05. Reconfiguration of cycle changing rooms at Level 1.
- 06. Finished floor levels, structural slab levels and spandrel heights amended.
- 07. Atria enclosure removed.

0 Architectural Scale  
 1 Architectural Scale  
 2 Architectural Scale  
 3 Architectural Scale  
 4 Architectural Scale  
 5 Architectural Scale  
 6 Architectural Scale  
 7 Architectural Scale  
 8 Architectural Scale  
 9 Architectural Scale  
 10 Architectural Scale  
 11 Architectural Scale  
 12 Architectural Scale  
 13 Architectural Scale  
 14 Architectural Scale  
 15 Architectural Scale  
 16 Architectural Scale  
 17 Architectural Scale  
 18 Architectural Scale  
 19 Architectural Scale  
 20 Architectural Scale  
 21 Architectural Scale  
 22 Architectural Scale  
 23 Architectural Scale  
 24 Architectural Scale  
 25 Architectural Scale  
 26 Architectural Scale  
 27 Architectural Scale  
 28 Architectural Scale  
 29 Architectural Scale  
 30 Architectural Scale  
 31 Architectural Scale  
 32 Architectural Scale  
 33 Architectural Scale  
 34 Architectural Scale  
 35 Architectural Scale  
 36 Architectural Scale  
 37 Architectural Scale  
 38 Architectural Scale  
 39 Architectural Scale  
 40 Architectural Scale  
 41 Architectural Scale  
 42 Architectural Scale  
 43 Architectural Scale  
 44 Architectural Scale  
 45 Architectural Scale  
 46 Architectural Scale  
 47 Architectural Scale  
 48 Architectural Scale  
 49 Architectural Scale  
 50 Architectural Scale  
 51 Architectural Scale  
 52 Architectural Scale  
 53 Architectural Scale  
 54 Architectural Scale  
 55 Architectural Scale  
 56 Architectural Scale  
 57 Architectural Scale  
 58 Architectural Scale  
 59 Architectural Scale  
 60 Architectural Scale  
 61 Architectural Scale  
 62 Architectural Scale  
 63 Architectural Scale  
 64 Architectural Scale  
 65 Architectural Scale  
 66 Architectural Scale  
 67 Architectural Scale  
 68 Architectural Scale  
 69 Architectural Scale  
 70 Architectural Scale  
 71 Architectural Scale  
 72 Architectural Scale  
 73 Architectural Scale  
 74 Architectural Scale  
 75 Architectural Scale  
 76 Architectural Scale  
 77 Architectural Scale  
 78 Architectural Scale  
 79 Architectural Scale  
 80 Architectural Scale  
 81 Architectural Scale  
 82 Architectural Scale  
 83 Architectural Scale  
 84 Architectural Scale  
 85 Architectural Scale  
 86 Architectural Scale  
 87 Architectural Scale  
 88 Architectural Scale  
 89 Architectural Scale  
 90 Architectural Scale  
 91 Architectural Scale  
 92 Architectural Scale  
 93 Architectural Scale  
 94 Architectural Scale  
 95 Architectural Scale  
 96 Architectural Scale  
 97 Architectural Scale  
 98 Architectural Scale  
 99 Architectural Scale  
 100 Architectural Scale

0 1m

**BENNETTS ASSOCIATES**  
 1 Ravelston Place, London EC1V 7NL  
 T +44(0)20 7 5222209 • www.bennettsassociates.com  
 E mail@bennettsassociates.com  
 For further information please contact our sales department  
 www.bennettsassociates.com/sales@bennettsassociates.com

Project 1503  
**Site T2 KXC**  
 Kings Cross Central Partnership Ltd.

Drawing Title  
**Facade Bay Study**  
 East Elevation  
 Level 9-10 Balcony / Sedum Roof

Drawing Number  
 KXC-T2-001-A-1503-P21-429 01

Scale @ A3 1:50  
 Scale @ A1 1:25  
 Revision Date 160415  
 YY MM DD







