

BASEMENT

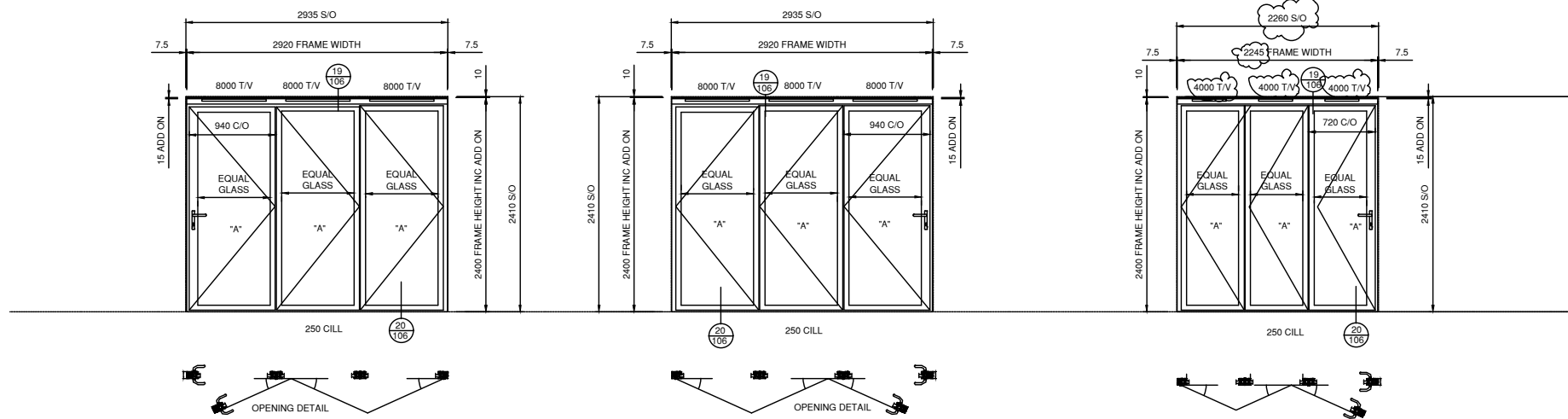

CLIENT DOOR REF: E-C (1)
 PLOT 4
 BI-FOLD DOOR - EXTERNAL OPENING
 3 x 5000mm EA TRICKLE VENT IN HEADER
 15mm ADD ON
 EQUAL SIZED LEAFS
 2400mm CLEAR OPENING (SINGLE LEAF)
 LOW THRESHOLD
 QUANTITY: 1 NR
 WINDOW SYSTEM -
 DUAL FRAME 75SI
 RAL 9005 (JET BLACK)

CLIENT DOOR REF: E-C (2)
 PLOT 3
 BI-FOLD DOOR - EXTERNAL OPENING
 3 x 5000mm EA TRICKLE VENT IN HEADER
 15mm ADD ON
 EQUAL SIZED LEAFS
 2400mm CLEAR OPENING (SINGLE LEAF)
 LOW THRESHOLD
 QUANTITY: 1 NR
 WINDOW SYSTEM -
 DUAL FRAME 75SI
 RAL 9005 (JET BLACK)

CLIENT DOOR REF: E-D
 PLOT 5
 BI-FOLD DOOR - EXTERNAL OPENING
 3 x 5000mm EA TRICKLE VENT IN HEADER
 15mm ADD ON
 EQUAL SIZED LEAFS
 2400mm CLEAR OPENING (SINGLE LEAF)
 LOW THRESHOLD
 QUANTITY: 1 NR
 WINDOW SYSTEM -
 DUAL FRAME 75SI
 RAL 9005 (JET BLACK)

NOTES

GLAZING SPECIFICATION:
 32mm TRIPLE GLAZED UNITS COMPRISING:
 MAX U VALUE FOR ALL UNITS 0.9W/m2K

"A"
 4mm CLEAR TOUGHENED-LOW E INNER
 10mm ARGON FILLED CAVITY
 (BLACK "warm edge" SPACER)
 4mm CLEAR FLOAT
 10mm ARGON FILLED CAVITY
 (BLACK "warm edge" SPACER)
 4mm CLEAR TOUGHENED OUTER

"B"
 4mm CLEAR FLOAT LOW E INNER
 10mm ARGON FILLED CAVITY
 (BLACK "warm edge" SPACER)
 4mm CLEAR FLOAT
 10mm ARGON FILLED CAVITY
 (BLACK "warm edge" SPACER)
 4mm CLEAR TOUGHENED OUTER

"C"
 4mm CLEAR TOUGHENED LOW E INNER
 10mm ARGON FILLED CAVITY
 (BLACK "warm edge" SPACER)
 4mm OBSCURE (SATINOVO) FLOAT
 10mm ARGON FILLED CAVITY
 (BLACK "warm edge" SPACER)
 4mm CLEAR TOUGHENED OUTER

"D"
 4mm CLEAR FLOAT LOW E INNER
 10mm ARGON FILLED CAVITY
 (BLACK "warm edge" SPACER)
 4mm OBSCURE (SATINOVO) FLOAT
 10mm ARGON FILLED CAVITY
 (BLACK "warm edge" SPACER)
 4mm CLEAR TOUGHENED OUTER

"E"
 6mm CLEAR TOUGHENED

"F"
 UNTREATED 18x75 IDIGBO SLATTED PANELS
 MOUNTED TO 28mm ALU INSULATED PANEL FINISHED IN RAL 9005 BOTH SIDES

"P"
 28mm ALU INSULATED PANEL FINISHED IN RAL 9005
 BOTH SIDES

SPECIFICATION:

ALUMINIUM FINISH
 - RAL 9005

TRICKLE VENTS:
 2500T/V = 2500mm2 ea, 8000T/V = 5000mm2 EA

DO NOT SCALE DRAWING
 ALL DIMENSIONS ARE IN MILLIMETRES
 ALL SIZES ARE MANUFACTURED SIZES

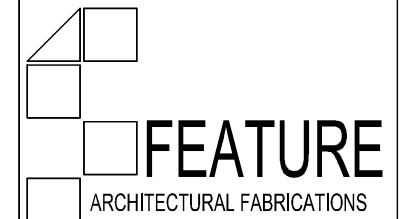

1 Harvington Business Park
 Brampton Road
 Eastbourne
 East Sussex
 BN22 9BN www.feature-fabrications.co.uk
 Tel: 01323 520404 Fax: 01323 520290

DRAWN BY: CM-FEATURE
 DATE: 09.06.2017

1 Detail No:
 100 Drawing No:

CLIENT: RYDON

TITLE: WINDOWS & DOORS ELEVATION
 (GROUND FLOOR & BASEMENT)

JOB REF: ASHTON COURT

DWG NO: 13274-001

SIZE: A3
 SCALE: 1:50
 REV: C

REVISION:
 REV A, CM 24.09.18 - REVEAL TO 150mm + ARCHITECT COMMENTS
 REV B, CM 01.10.18 - REVISED IN LINE WITH ARCHITECT COMMENTS
 REV C, CM 10.01.19 - BI-FOLD DOORS TO LOW THRESHOLD

GROUND FLOOR

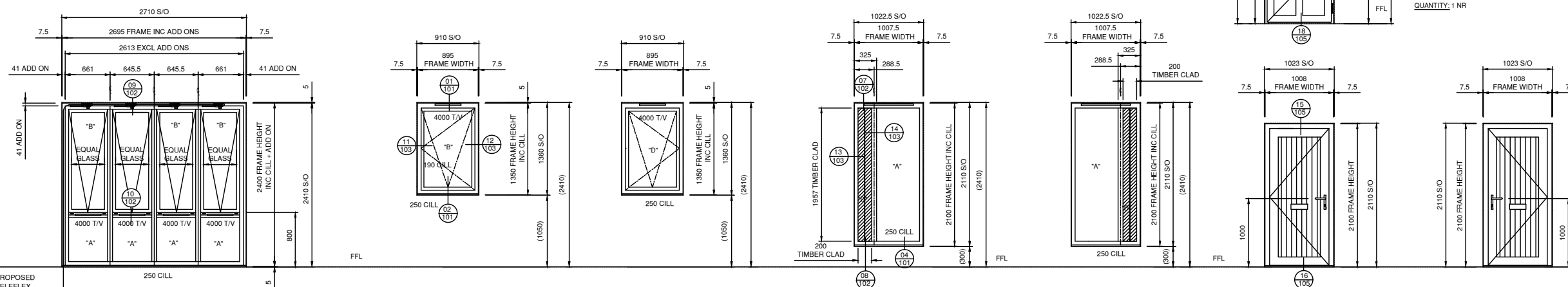

PROPOSED TELEFLEX CABLE ROUTE TO BASEMENT

CLIENT WINDOW REF: E-A
 41mm ADD ON TOP AND SIDES FOR TELEFLEX PACKAGE
 INWARD OPENING
 NO LOCKABLE RESTRICTOR STAYS I.L.O. TELEFLEX
 4 x 2500mm EA TRICKLE VENT IN TRANSOM
 QUANTITY: 5 NR
 WINDOW SYSTEM -
 DUAL FRAME 75SI
 RAL 9005 (JET BLACK)

CLIENT WINDOW REF: E-B (1)
 DEEP SECTION HEADER DF1411
 INWARD OPENING TBT
 1 x 2500mm EA TRICKLE VENT IN HEADER
 QUANTITY: 4 NR (2 GROUND FLOOR, 2 FIRST FLOOR)
 OBSCURE GLAZE GROUND FLOOR ONLY
 WINDOW SYSTEM -
 DUAL FRAME 75SI
 RAL 9005 (JET BLACK)

CLIENT WINDOW REF: E-B (2)
 DEEP SECTION HEADER DF1411
 INWARD OPENING
 1 x 2500mm EA TRICKLE VENT IN HEADER
 QUANTITY: 4 NR (2 GROUND FLOOR, 2 FIRST FLOOR)
 OBSCURE GLAZE GROUND FLOOR ONLY
 WINDOW SYSTEM -
 DUAL FRAME 75SI
 RAL 9005 (JET BLACK)

CLIENT WINDOW REF: E-F (1)
 DEEP SECTION HEADER DF1411
 1 x 5000MM TRICKLE VENT IN HEADER
 LH PANEL IDIGBO HARDWOOD CLAD
 QUANTITY: 4 NR (2 GROUND FLOOR, 2 FIRST FLOOR)
 WINDOW SYSTEM -
 DUAL FRAME 75SI
 RAL 9005 (JET BLACK)

CLIENT WINDOW REF: E-F (2)
 DEEP SECTION HEADER DF1411
 1 x 5000MM TRICKLE VENT IN HEADER
 LH PANEL IDIGBO HARDWOOD CLAD
 QUANTITY: 3 NR (1 GROUND FLOOR, 2 FIRST FLOOR)
 WINDOW SYSTEM -
 DUAL FRAME 75SI
 RAL 9005 (JET BLACK)

CLIENT DOOR REF: E-B (1)
 LOBBY INTERNAL DOOR
 LH OPEN IN
 QUANTITY: 2 NR
 COMPOSITE DOOR SPEC.
 LH OPEN IN
 DISTINCTION 'RETAIL COTTAGE' SOLID DOOR
 BRUSHED STAINLESS STEEL LEVER
 HANDLES
 WINKHOUSE TRU LOCK WITH KEY / KEY CYLINDER
 LOW RAMP 'ENHANCED' THRESHOLD, FOR PART M COMPLIANCE (STORMGAURD PROLINE AM3 OR EQUIVALENT).
 BRUSHED STAINLESS STEEL LETTERBOX
 EFFECTIVE DOOR CLEAR OPENING > 800mm
 (WHEN OPENED TO MAX 98 DEGREES)
 SBD SPEC.

COMPOSITE DOOR COLOUR:
 - WHITE (INTERNALLY)
 - BLACK (EXTERNALLY)
 - WHITE FRAME, FOIL BLACK EXTERNALLY.

CLIENT DOOR REF: E-B (1)
 LOBBY INTERNAL DOOR
 RH OPEN IN
 QUANTITY: 3 NR
 COMPOSITE DOOR SPEC.
 RH OPEN IN
 DISTINCTION 'RETAIL COTTAGE' SOLID DOOR
 BRUSHED STAINLESS STEEL LEVER HANDLES
 WINKHOUSE TRU LOCK WITH KEY / KEY CYLINDER
 LOW RAMP 'ENHANCED' THRESHOLD, FOR PART M COMPLIANCE (STORMGAURD PROLINE AM3 OR EQUIVALENT).
 BRUSHED STAINLESS STEEL LETTERBOX
 EFFECTIVE DOOR CLEAR OPENING > 800mm
 (WHEN OPENED TO MAX 98 DEGREES)
 SBD SPEC.

COMPOSITE DOOR COLOUR:
 - WHITE (INTERNALLY)
 - BLACK (EXTERNALLY)
 - WHITE FRAME, FOIL BLACK EXTERNALLY.

FIRST FLOOR

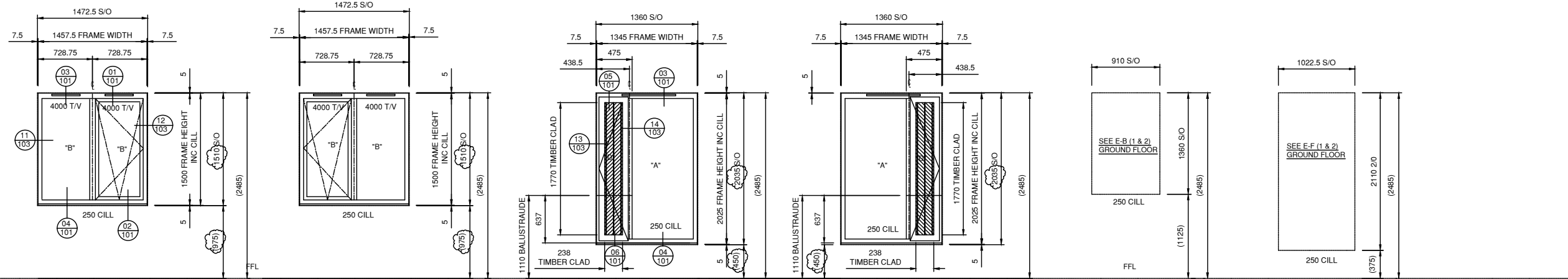

CLIENT WINDOW REF: E-D (1)
DEEP SECTION HEADER DF1411
RH SASH
TILT / TURN
RESTRICTOR STAYS
2 x 2500mm EA TRICKLE VENT
QUANTITY: 2 NR
WINDOW SYSTEM -
DUAL FRAME 75SI
RAL 9005 (JET BLACK)

CLIENT WINDOW REF: E-D (2)
DEEP SECTION HEADER DF1411
LH SASH
TILT / TURN
RESTRICTOR STAYS
2 x 2500mm EA TRICKLE VENT
QUANTITY: 3 NR
WINDOW SYSTEM -
DUAL FRAME 75SI
RAL 9005 (JET BLACK)

CLIENT WINDOW REF: E-C (1)
QUANTITY: 2 NR
DEEP SECTION HEADER DF1411
LH SASH
OPEN OUT
RESTRICTOR STAYS
1 x 5000mm TRICKLE VENT IN HEADER
WINDOW SYSTEM -
DUAL FRAME 75SI
RAL 9005 (JET BLACK)
LH PANEL IROKO HARDWOOD CLAD
STAIN "SWEET CHESTNUT"

CLIENT WINDOW REF: E-C (2)
QUANTITY: 3 NR
DEEP SECTION HEADER DF1411
RH SASH
OPEN OUT
RESTRICTOR STAYS
1 x 5000mm TRICKLE VENT IN HEADER
WINDOW SYSTEM -
DUAL FRAME 75SI
RAL 9005 (JET BLACK)
LH PANEL IROKO HARDWOOD CLAD
STAIN "SWEET CHESTNUT"

CLIENT WINDOW REF: E-F (2)
QUANTITY: 3 NR
WINDOW SYSTEM -
DUAL FRAME 75SI
RAL 9005 (JET BLACK)
RH PANEL IROKO HARDWOOD CLAD
STAIN "SWEET CHESTNUT"

SECOND FLOOR

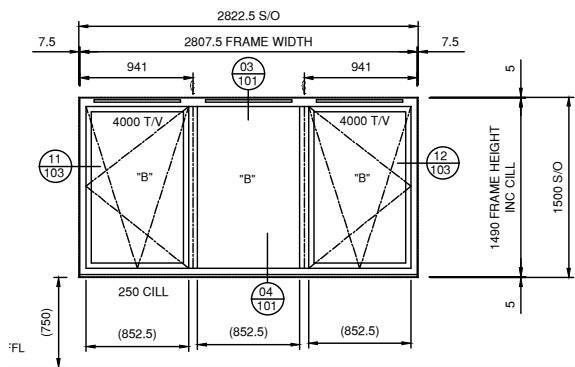

CLIENT WINDOW REF: E-E
INWARD OPENING
RESTRICTOR STAYS
2 x 2500mm EA TRICKLE VENT LIP TO LIP
QUANTITY: 5 NR
WINDOW SYSTEM -
DUAL FRAME 75SI
RAL 9005 (JET BLACK)

NOTES

GLAZING SPECIFICATION:
32mm TRIPLE GLAZED UNITS COMPRISING:

MAX U VALUE FOR ALL UNITS 0.9W/m²K

"A"
4mm CLEAR TOUGHENED-LOW E INNER
10mm ARGON FILLED CAVITY
(BLACK "warm edge" SPACER)
4mm CLEAR FLOAT
10mm ARGON FILLED CAVITY
(BLACK "warm edge" SPACER)
4mm CLEAR TOUGHENED OUTER
"B"
4mm CLEAR FLOAT LOW E INNER
10mm ARGON FILLED CAVITY
(BLACK "warm edge" SPACER)
4mm CLEAR FLOAT
10mm ARGON FILLED CAVITY
(BLACK "warm edge" SPACER)
4mm CLEAR FLOAT OUTER
"C"
4mm CLEAR TOUGHENED LOW E INNER
10mm ARGON FILLED CAVITY
(BLACK "warm edge" SPACER)
4mm OBSCURE (SATINOVO) FLOAT
10mm ARGON FILLED CAVITY
(BLACK "warm edge" SPACER)
4mm CLEAR TOUGHENED OUTER
"D"
4mm CLEAR FLOAT LOW E INNER
10mm ARGON FILLED CAVITY
(BLACK "warm edge" SPACER)
4mm OBSCURE (SATINOVO) FLOAT
10mm ARGON FILLED CAVITY
(BLACK "warm edge" SPACER)
4mm CLEAR FLOAT OUTER

"E"
6mm CLEAR TOUGHENED
"F"
UNTREATED 18x75 IDIGBO SLATTED PANELS
MOUNTED TO 28mm ALU INSULATED PANEL FINISHED
IN RAL 9005 BOTH SIDES

"P"
28mm ALU INSULATED PANEL FINISHED IN RAL 9005
BOTH SIDES

ALUMINIUM FINISH
- RAL 9005
TRICKLE VENTS:
2500T/V = 2500mm² ea, 8000T/V = 5000mm² EA

DO NOT SCALE DRAWING
ALL DIMENSIONS ARE IN MILLIMETRES
ALL SIZES ARE MANUFACTURED SIZES

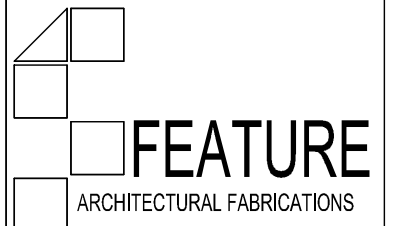

1 Harvington Business Park
Brampton Road
Eastbourne
East Sussex
BN22 9BN www.feature-fabrications.co.uk
Tel: 01323 520404 Fax: 01323 520290

DRAWN BY: CM-FEATURE	DATE: 09.06.2017
1 100	Detail No: Drawing No:

CLIENT: **RYDON**

TITLE: **WINDOWS & DOORS ELEVATION
(FIRST AND SECOND FLOORS)**

JOB REF: **ASHTON COURT**

DWG NO: **13274-002**

SIZE: A3	SCALE: 1:50	REV: B
--------------------	-----------------------	------------------

REVISION:
REV A, CM 24.09.18 - REVEAL TO 150mm + ARCHITECT COMMENTS
REV B, CM 01.10.18 - REVISED IN LINE WITH ARCHITECT COMMENTS

SPECIFICATION:

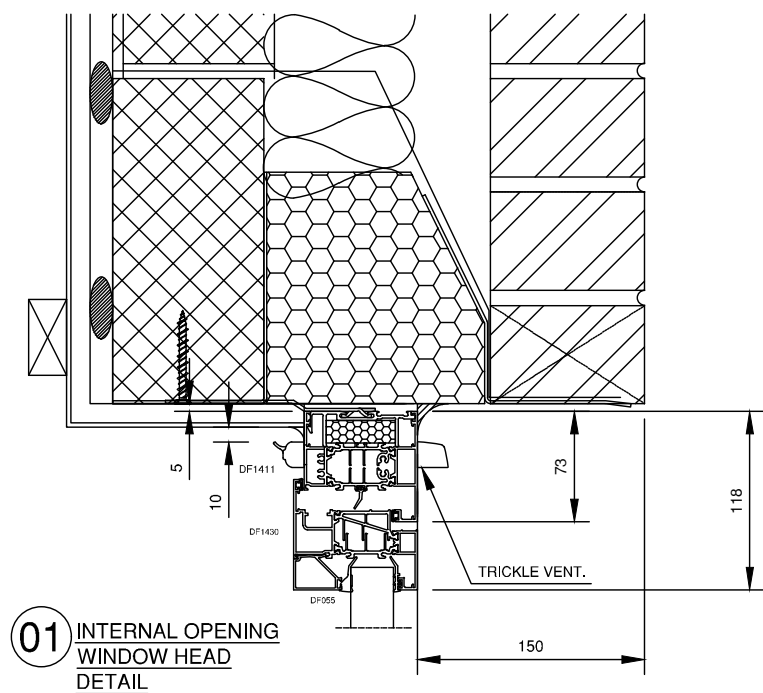

01 INTERNAL OPENING WINDOW HEAD DETAIL

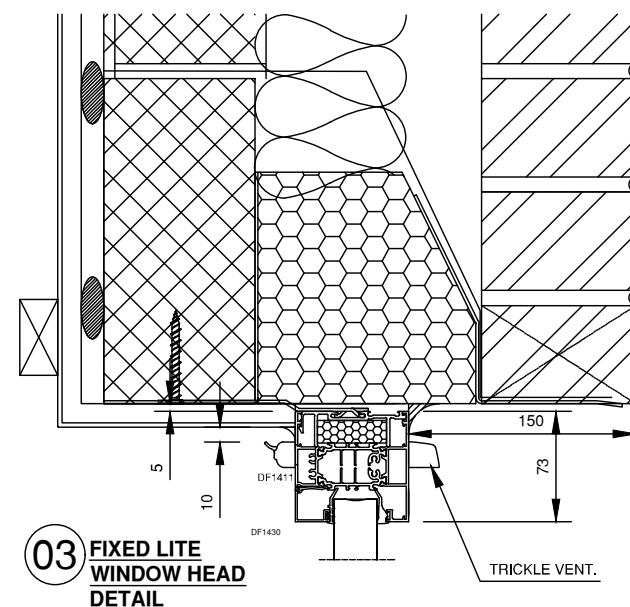

03 FIXED LITE WINDOW HEAD DETAIL

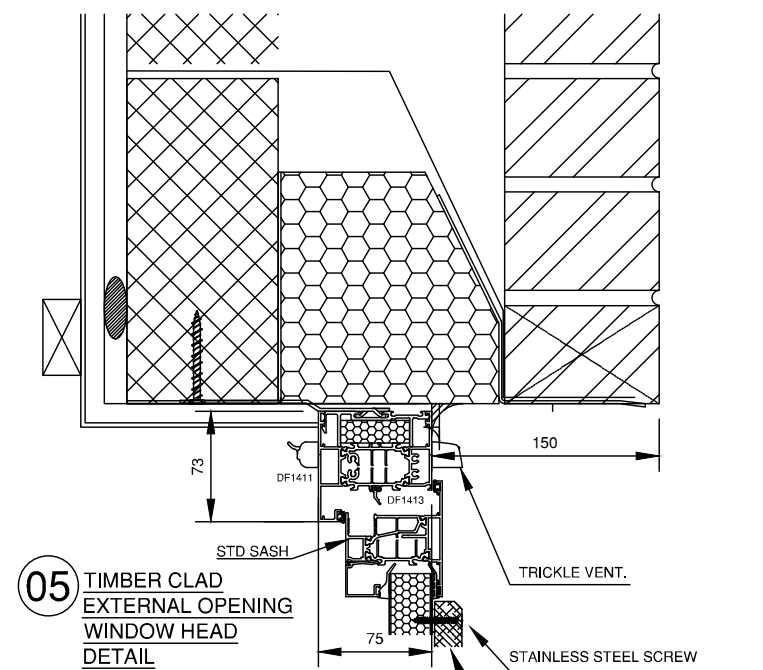

05 TIMBER CLAD EXTERNAL OPENING WINDOW HEAD DETAIL

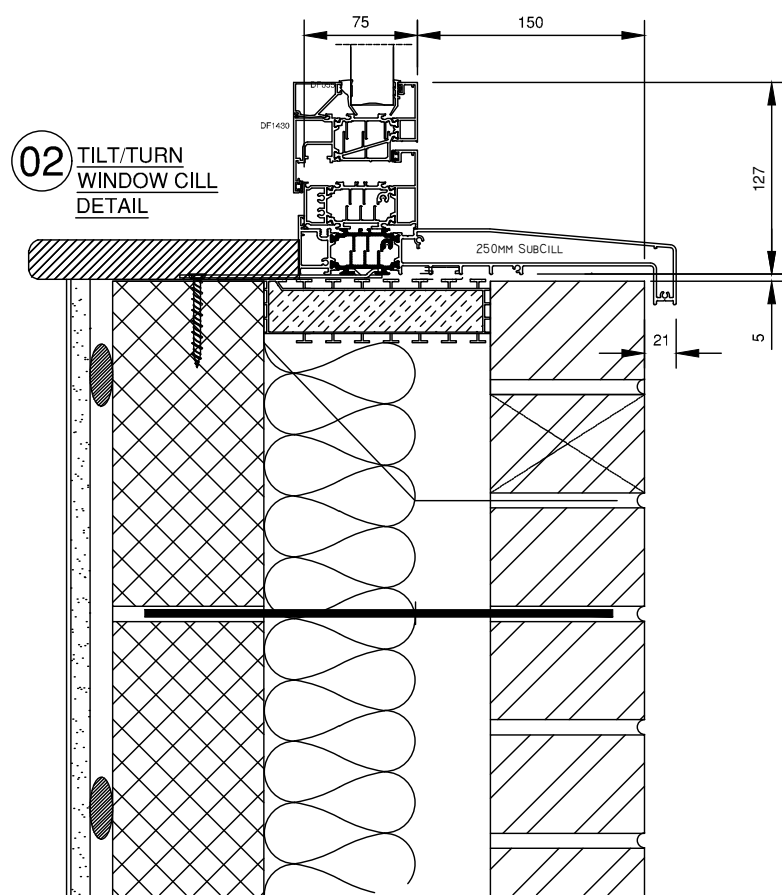

02 TILT/TURN WINDOW CILL DETAIL

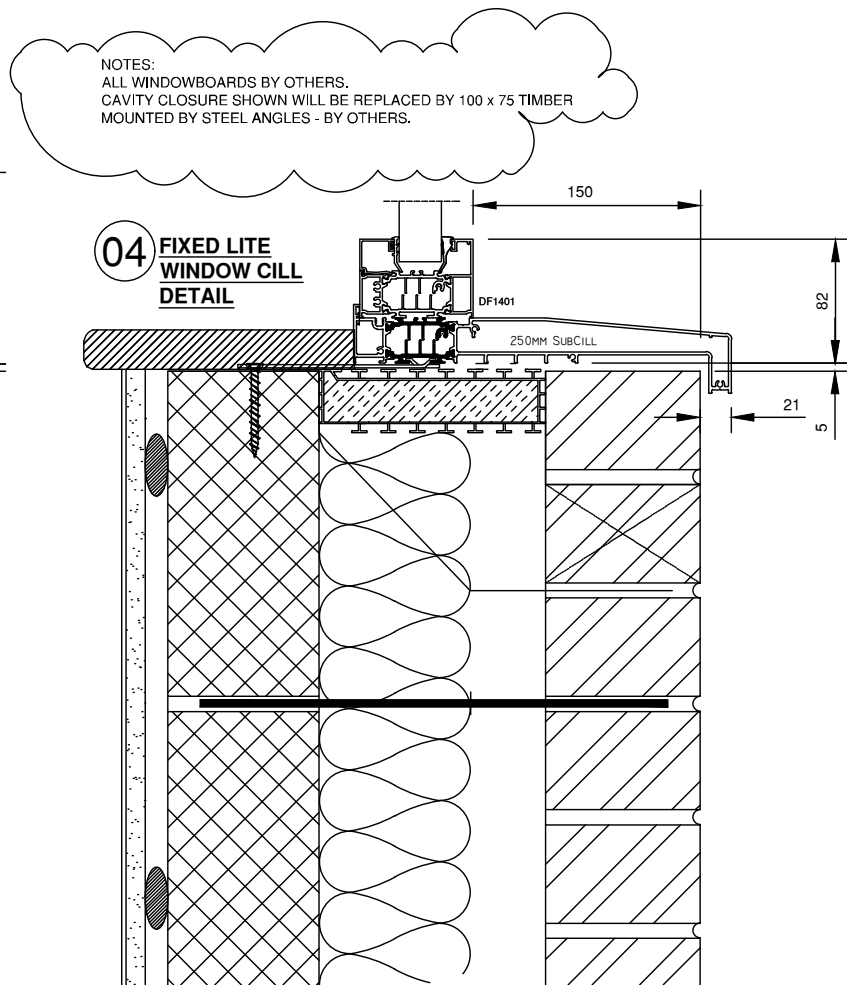

04 FIXED LITE WINDOW CILL DETAIL

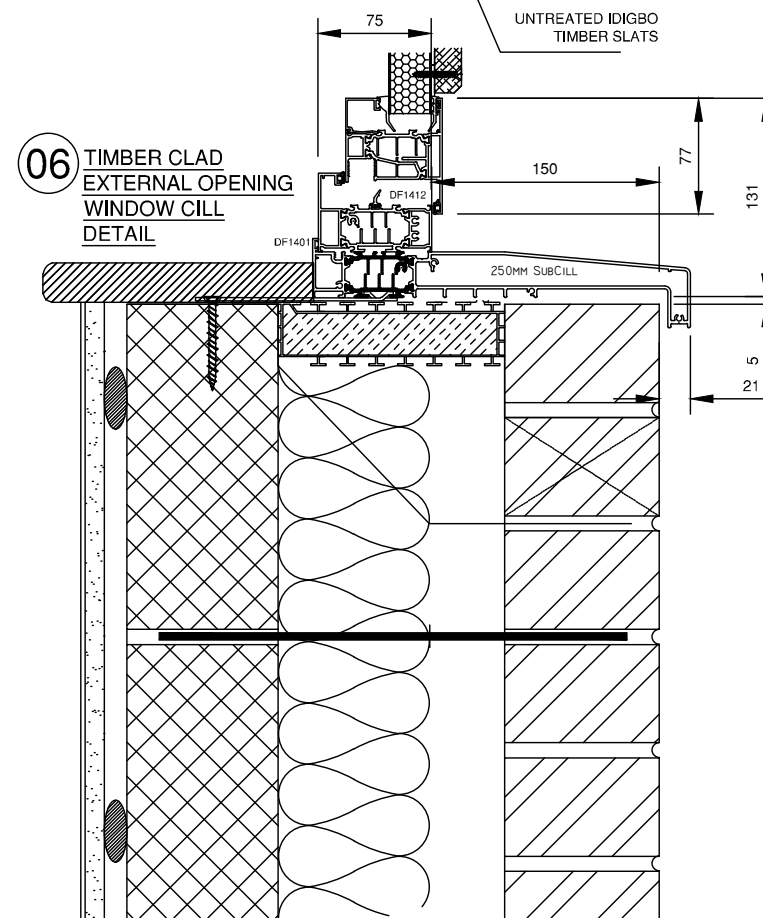

06 TIMBER CLAD EXTERNAL OPENING WINDOW CILL DETAIL

NOTES:
ALL WINDOWBOARDS BY OTHERS.
CAVITY CLOSURE SHOWN WILL BE REPLACED BY 100 x 75 TIMBER MOUNTED BY STEEL ANGLES - BY OTHERS.

DO NOT SCALE DRAWING
ALL DIMENSIONS ARE IN MILLIMETRES
ALL SIZES ARE MANUFACTURED SIZES

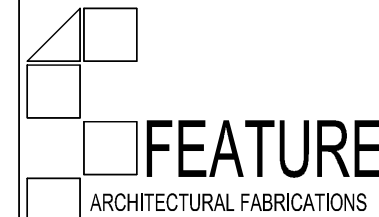

1 Harvington Business Park
Brampton Road
Eastbourne
East Sussex
BN22 9BN www.feature-fabrications.co.uk
Tel: 01323 520404 Fax: 01323 520290

DRAWN BY: CM-FEATURE
DATE: 09.06.2017

1 Detail No:
100 Drawing No:

CLIENT: RYDON

TITLE: WINDOWS & DOORS ELEVATION

JOB REF: ASHTON COURT SECTION DETAILS

DWG NO: 13274-101

SIZE: A3 SCALE: 1:50 REV: B

REVISION:
REV A, CM 24.09.18 - REVEAL TO 150mm + ARCHITECT COMMENTS
REV B, CM 01.10.18 - REVISED IN LINE WITH ARCHITECT COMMENTS

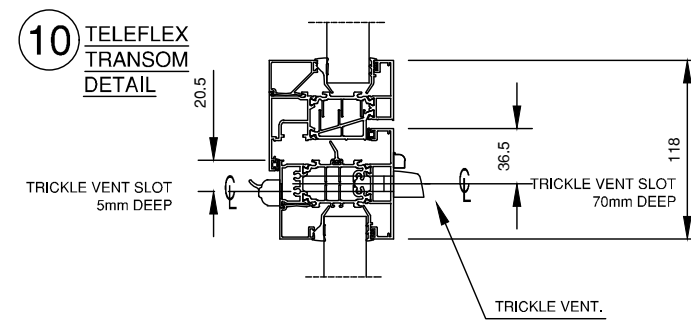
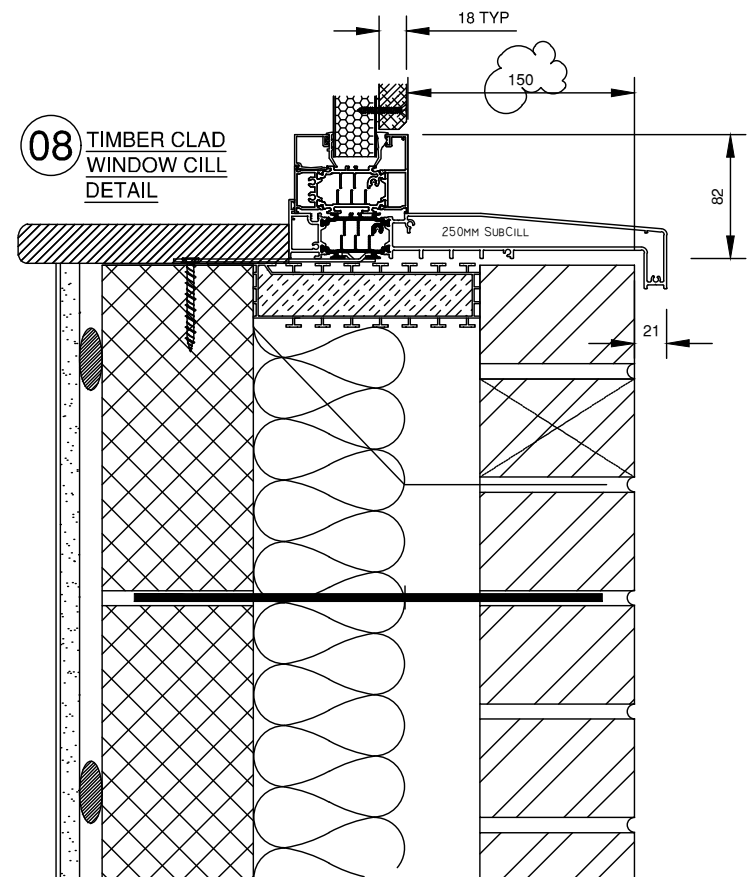
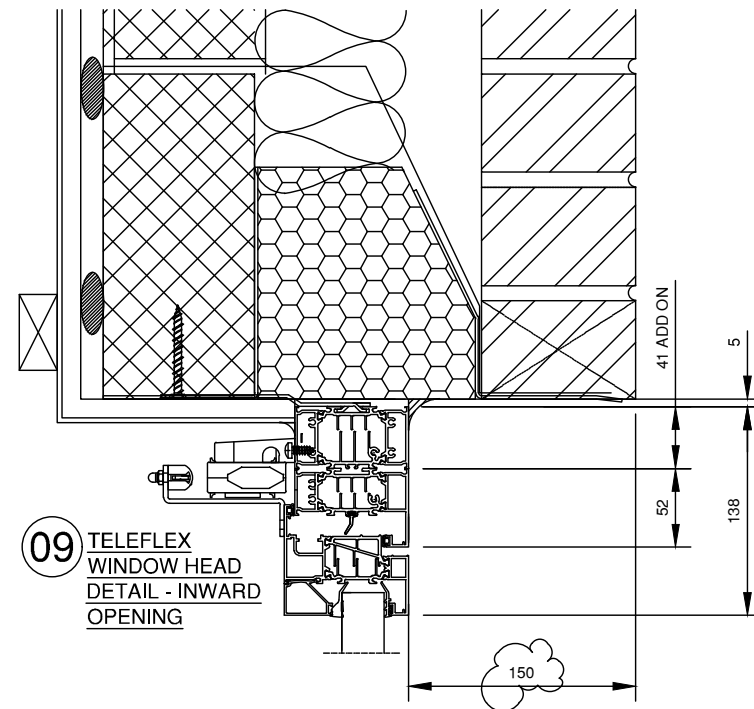
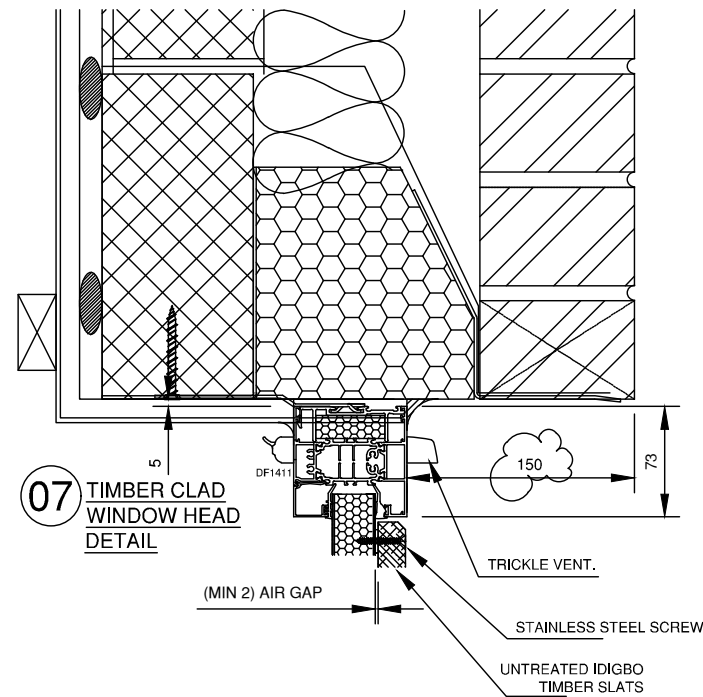

SPECIFICATION:

DO NOT SCALE DRAWING
ALL DIMENSIONS ARE IN MILLIMETRES
ALL SIZES ARE MANUFACTURED SIZES

FEATURE
ARCHITECTURAL FABRICATIONS

1 Harvington Business Park
Brampton Road
Eastbourne
East Sussex
BN22 9BN www.feature-fabrications.co.uk
Tel: 01323 520404 Fax: 01323 520290

DRAWN BY: **CM-FEATURE** DATE: **09.06.2017**

1 Detail No:
100 Drawing No:

CLIENT: **RYDON**

TITLE: **WINDOWS & DOORS ELEVATION**

JOB REF: **ASHTON COURT
SECTION DETAILS**

DWG NO: **13274-102**

SIZE: **A3** SCALE: **1:50** REV: **B**

REVISION:
REV A, CM 24.09.18 - REVEAL TO 150mm + ARCHITECT COMMENTS
REV B, CM 01.10.18 - REVISED IN LINE WITH ARCHITECT COMMENTS

SPECIFICATION:

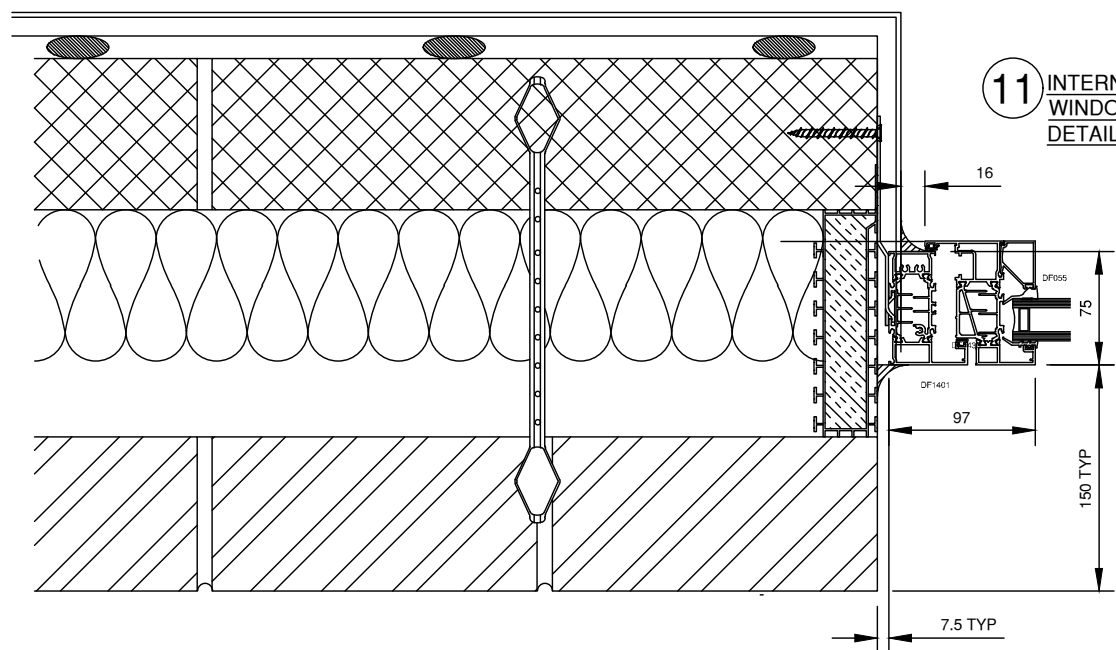

11 INTERNAL OPENING WINDOW JAMB DETAIL

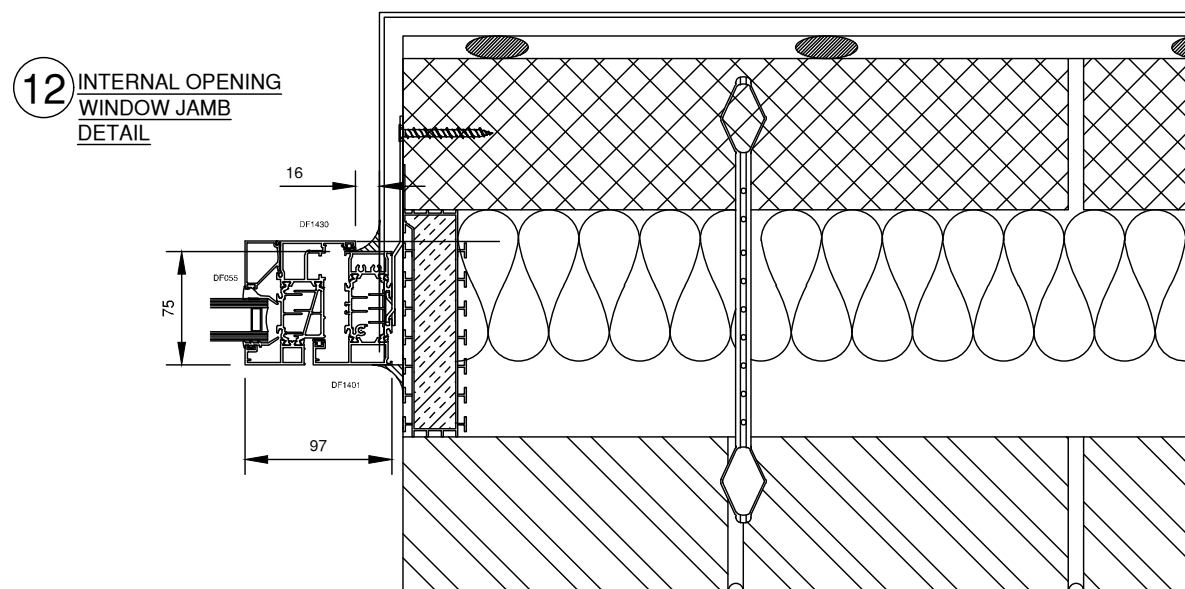

12 INTERNAL OPENING WINDOW JAMB DETAIL

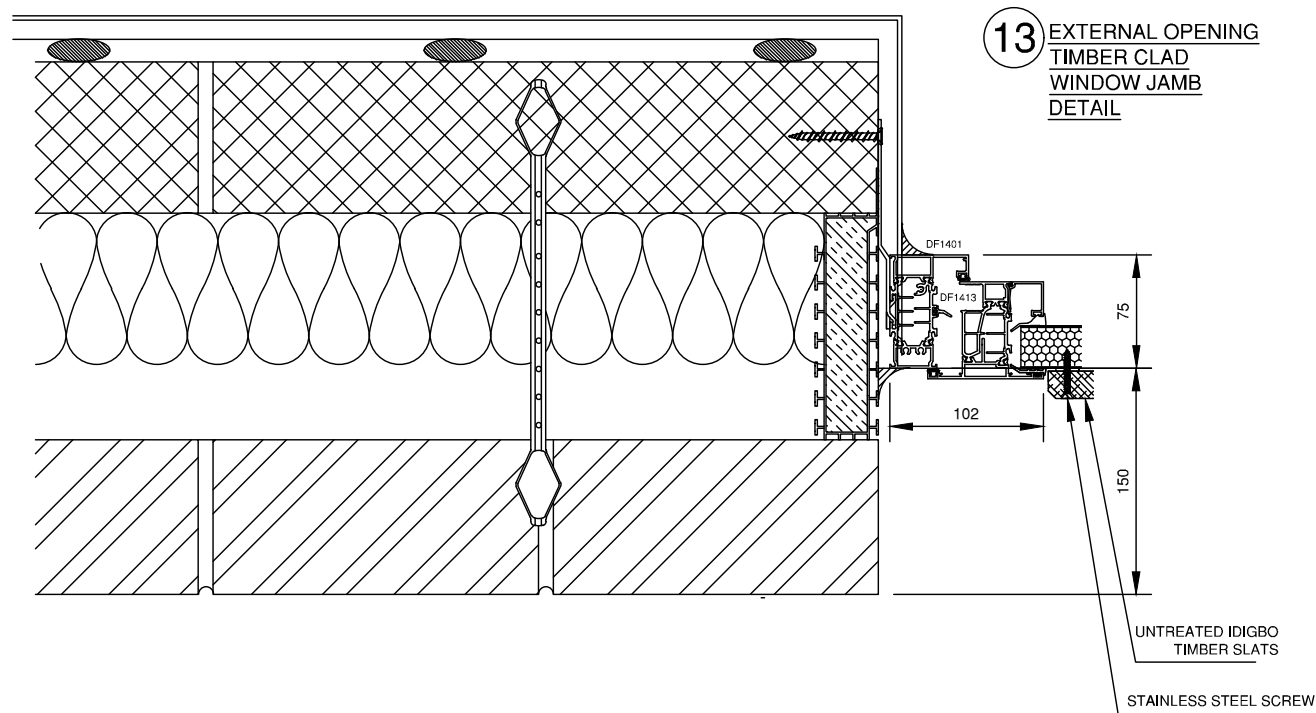

13 EXTERNAL OPENING TIMBER CLAD WINDOW JAMB DETAIL

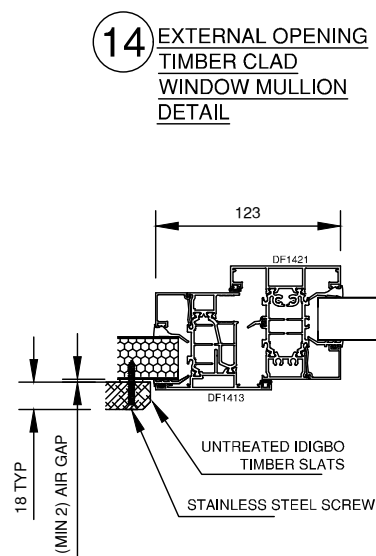

14 EXTERNAL OPENING TIMBER CLAD WINDOW MULLION DETAIL

DO NOT SCALE DRAWING
ALL DIMENSIONS ARE IN MILLIMETRES
ALL SIZES ARE MANUFACTURED SIZES

FEATURE
ARCHITECTURAL FABRICATIONS

1 Harvington Business Park
Brampton Road
Eastbourne
East Sussex
BN22 9BN www.feature-fabrications.co.uk
Tel: 01323 520404 Fax: 01323 520290

DRAWN BY: **CM-FEATURE** DATE: **09.06.2017**

1 Detail No:
100 Drawing No:

CLIENT: **RYDON**

TITLE: **WINDOWS & DOORS ELEVATION**

JOB REF: **ASHTON COURT SECTION DETAILS**

DWG NO: **13274-103**

SIZE: **A3** SCALE: **1:50** REV: **B**

REVISION:
REV A, CM 24.09.18 - REVEAL TO 150mm + ARCHITECT COMMENTS
REV B, CM 01.10.18 - REVISED IN LINE WITH ARCHITECT COMMENTS

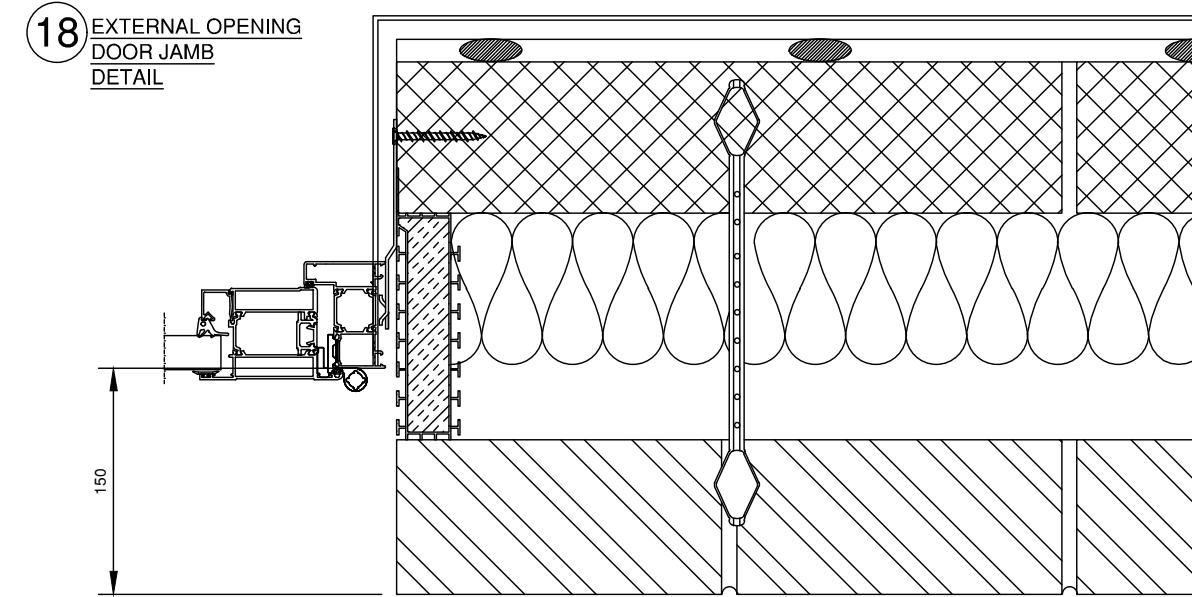
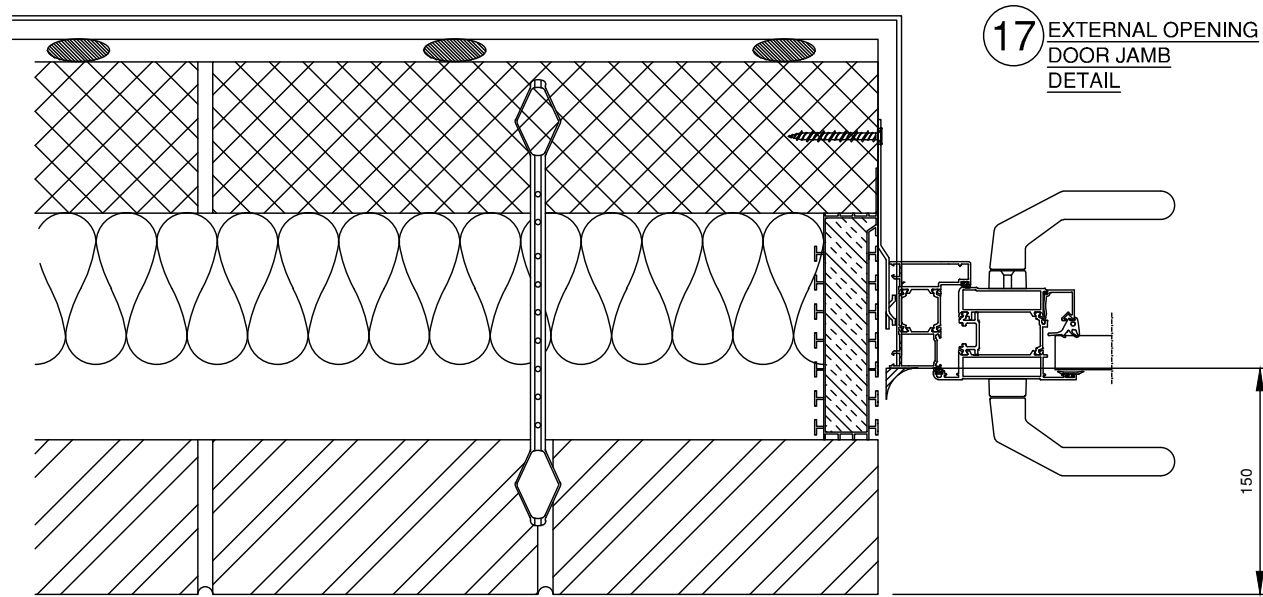
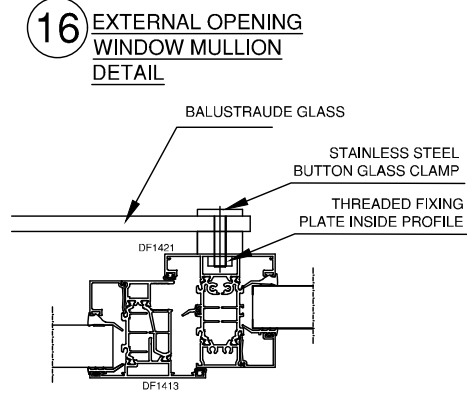
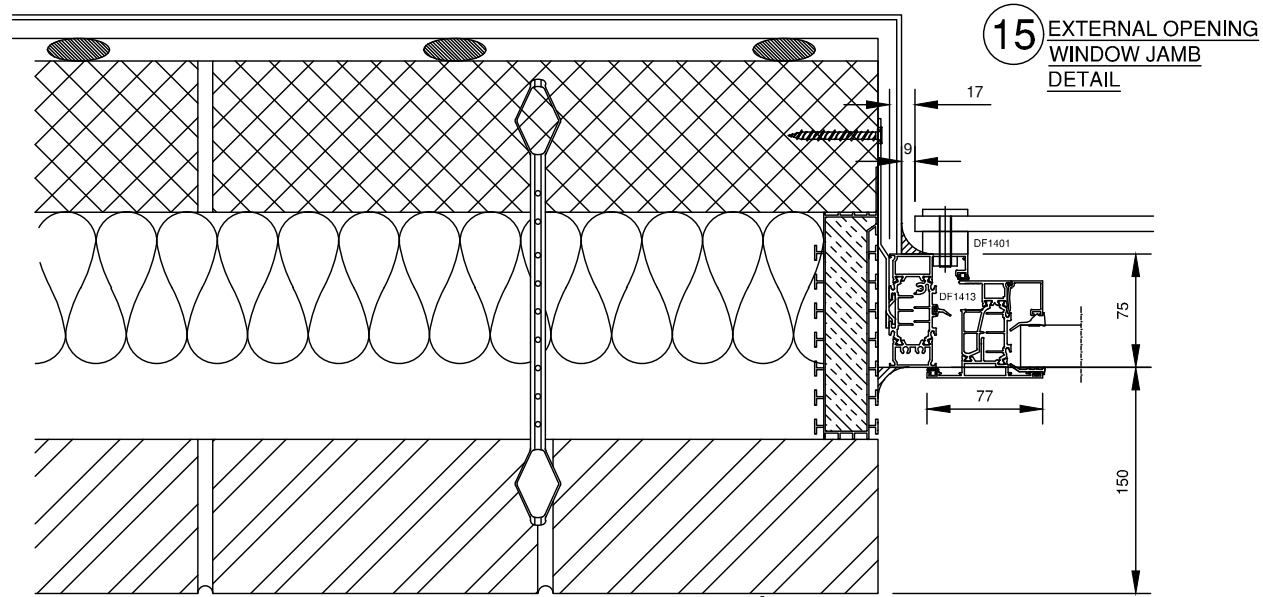

SPECIFICATION:

DO NOT SCALE DRAWING
ALL DIMENSIONS ARE IN MILLIMETRES
ALL SIZES ARE MANUFACTURED SIZES

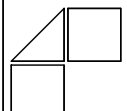
FEATURE
 ARCHITECTURAL FABRICATIONS

1 Harvington Business Park
 Brampton Road
 Eastbourne
 East Sussex
 BN22 9BN www.feature-fabrications.co.uk
 Tel: 01323 520404 Fax: 01323 520290

DRAWN BY: **CM-FEATURE** DATE: **09.06.2017**

1 Detail No:
 100 Drawing No:

CLIENT: **RYDON**

TITLE: **WINDOWS & DOORS ELEVATION**

JOB REF: **ASHTON COURT SECTION DETAILS**

DWG NO: **13274-104**

SIZE: **A3** SCALE: **1:50** REV: **B**

REVISION:

REV A, CM 24.09.18 - REVEAL TO 150mm + ARCHITECT COMMENTS
 REV B, CM 01.10.18 - REVISED IN LINE WITH ARCHITECT COMMENTS

SPECIFICATION:

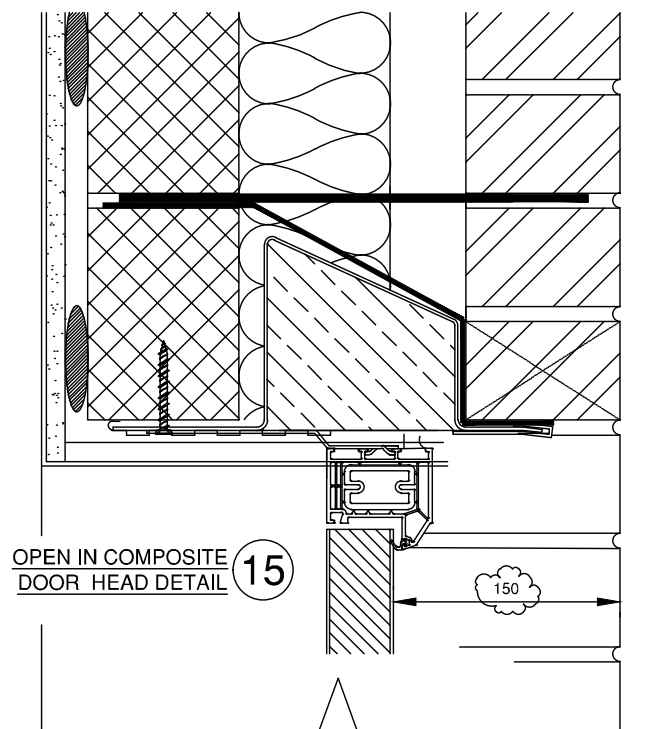

OPEN IN COMPOSITE DOOR HEAD DETAIL 15

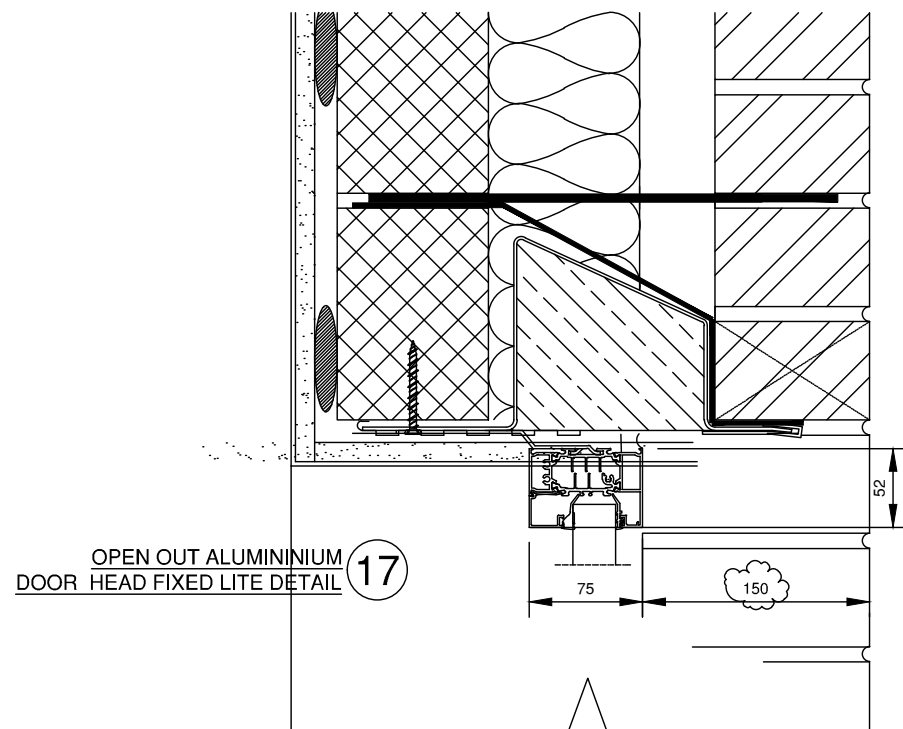

OPEN OUT ALUMINIUM DOOR HEAD FIXED LITE DETAIL 17

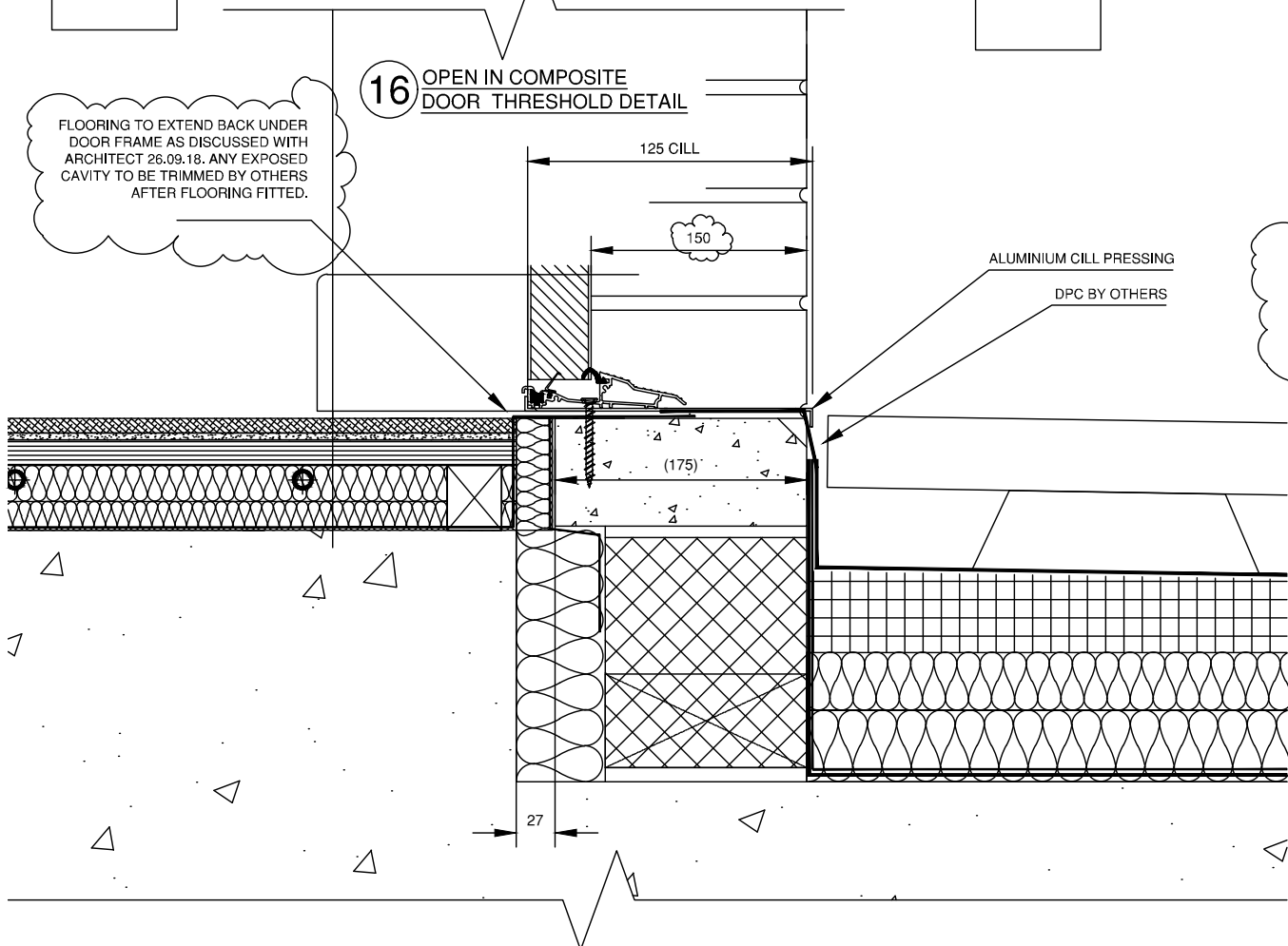

OPEN IN COMPOSITE DOOR THRESHOLD DETAIL 16

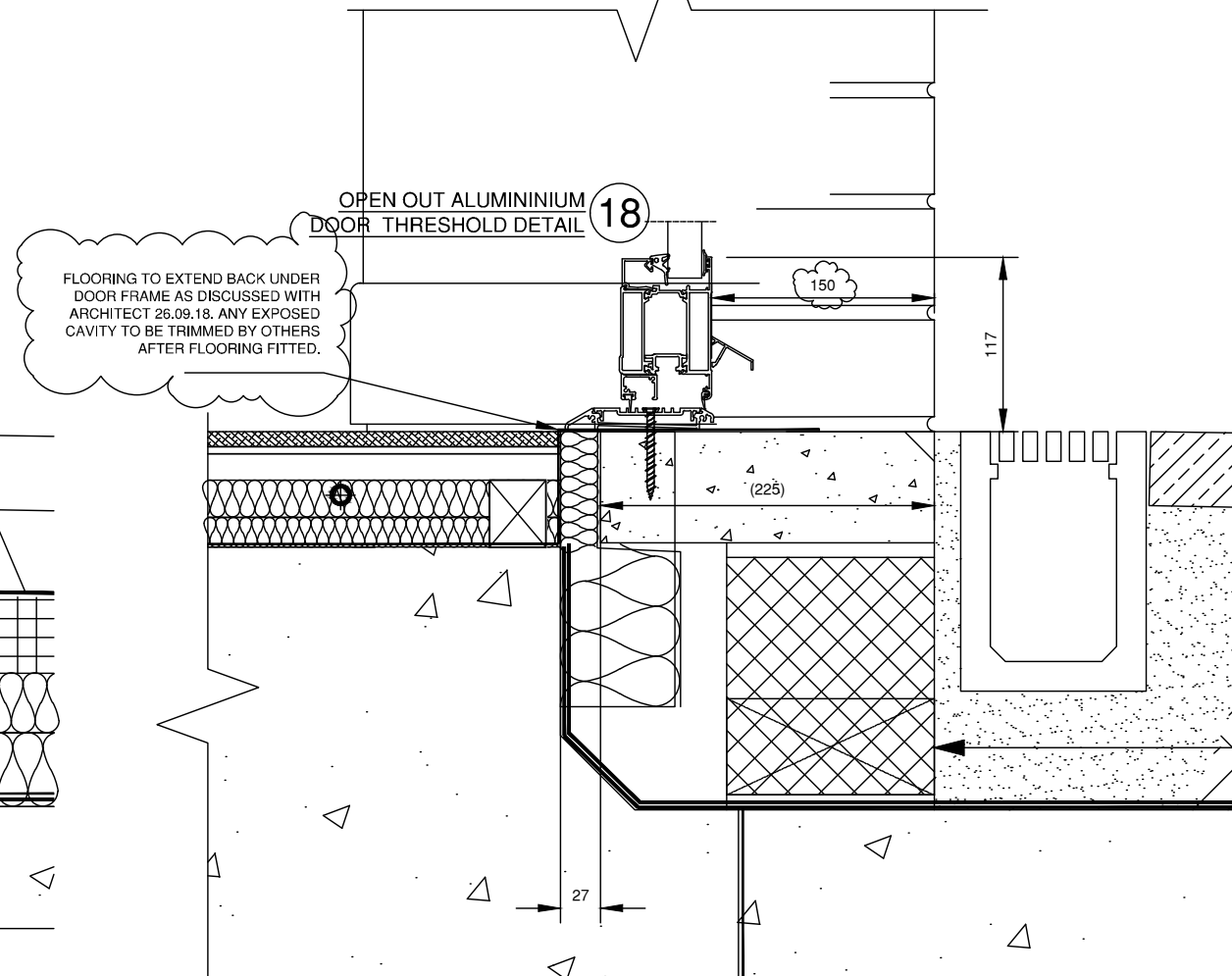

OPEN OUT ALUMINIUM DOOR THRESHOLD DETAIL 18

DO NOT SCALE DRAWING
ALL DIMENSIONS ARE IN MILLIMETRES
ALL SIZES ARE MANUFACTURED SIZES

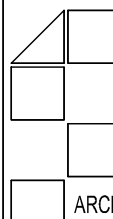
FEATURE
 ARCHITECTURAL FABRICATIONS

1 Harvington Business Park
 Brampton Road
 Eastbourne
 East Sussex
 BN22 9BN www.feature-fabrications.co.uk
 Tel: 01323 520404 Fax: 01323 520290

DRAWN BY: **CM-FEATURE** DATE: **09.06.2017**

1 Detail No:
 100 Drawing No:

CLIENT: **RYDON**

TITLE: **WINDOWS & DOORS ELEVATION**

JOB REF: **ASHTON COURT SECTION DETAILS**

DWG NO: **13274-105**

SIZE: **A3** SCALE: **1:50** REV: **B**

REVISION:
 REV A, CM 24.09.18 - REVEAL TO 150mm + ARCHITECT COMMENTS
 REV B, CM 01.10.18 - REVISED IN LINE WITH ARCHITECT COMMENTS

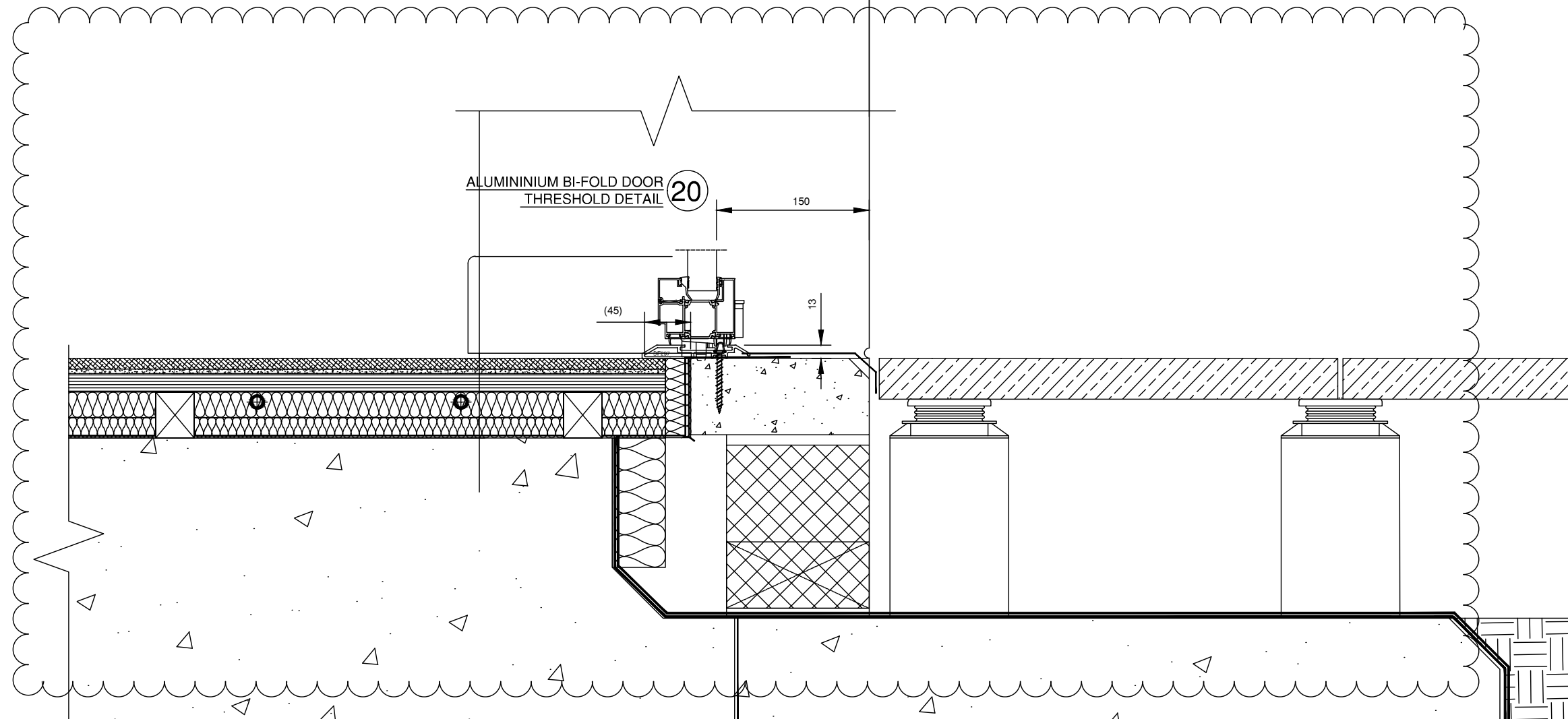
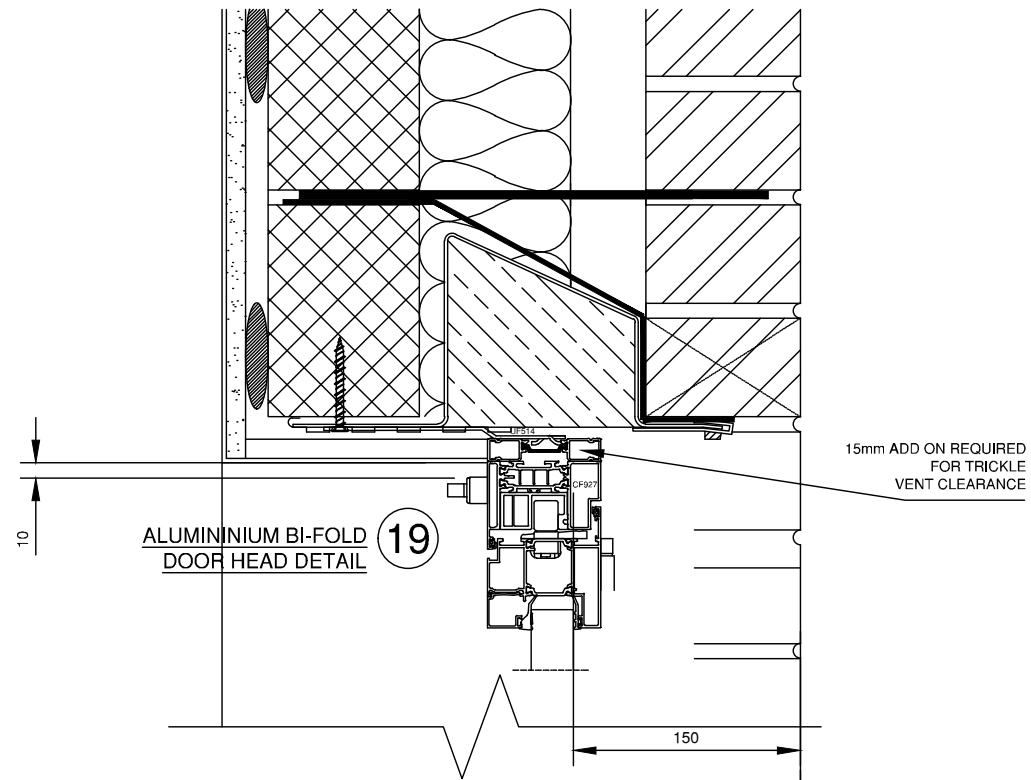

SPECIFICATION:

DO NOT SCALE DRAWING
ALL DIMENSIONS ARE IN MILLIMETRES
ALL SIZES ARE MANUFACTURED SIZES

FEATURE
 ARCHITECTURAL FABRICATIONS

1 Harvington Business Park
Brampton Road
Eastbourne
East Sussex
BN22 9BN www.feature-fabrications.co.uk
Tel: 01323 520404 Fax: 01323 520290

DRAWN BY: **CM-FEATURE** DATE: **09.06.2017**

1 Detail No:
100 Drawing No:

CLIENT: **RYDON**

TITLE: **WINDOWS & DOORS ELEVATION**

JOB REF: **ASHTON COURT SECTION DETAILS**

DWG NO: **13274-106**

SIZE: **A3** SCALE: **1:50** REV: **C**

REVISION:

REV A, CM 24.09.18 - REVEAL TO 150mm + ARCHITECT COMMENTS
REV B, CM 01.10.18 - REVISED IN LINE WITH ARCHITECT COMMENTS
REV C, CM 10.01.19 - BI-FOLD DOORS TO LOW THRESHOLD