

**Detail of proposed Section A-A at 1/25**

To install 1@ Velux-type conservation roof window  
78cm x 140cm, e.g.  
Velux Model:  
GPL SD5 MK08

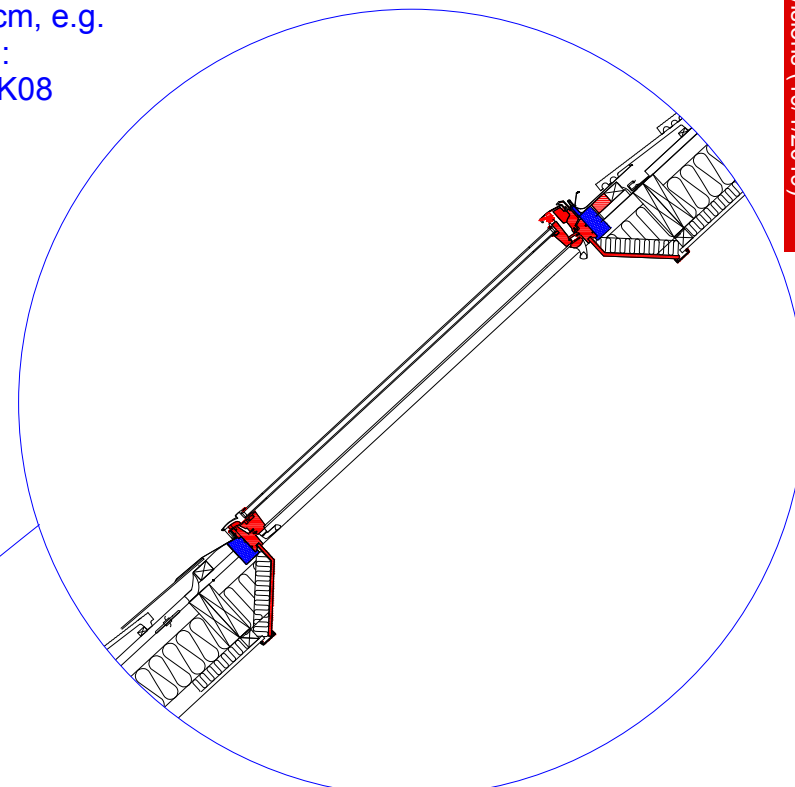

drawing n°:  
**NW36AJ-RW-002**  
last rev. date:  
no revisions (10/1/2019)

**Existing Front Elevation**  
also indicating line of proposed Section A-A  
(Scale 1:100)

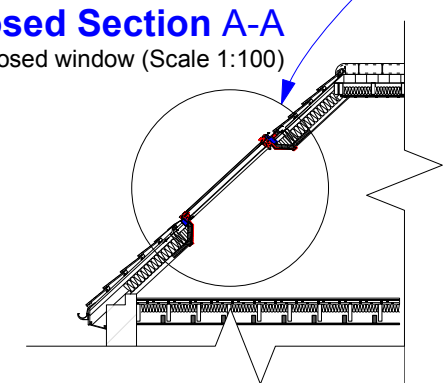

**Existing internal layout**

also indicating line of proposed Section A-A  
(Scale 1:100)

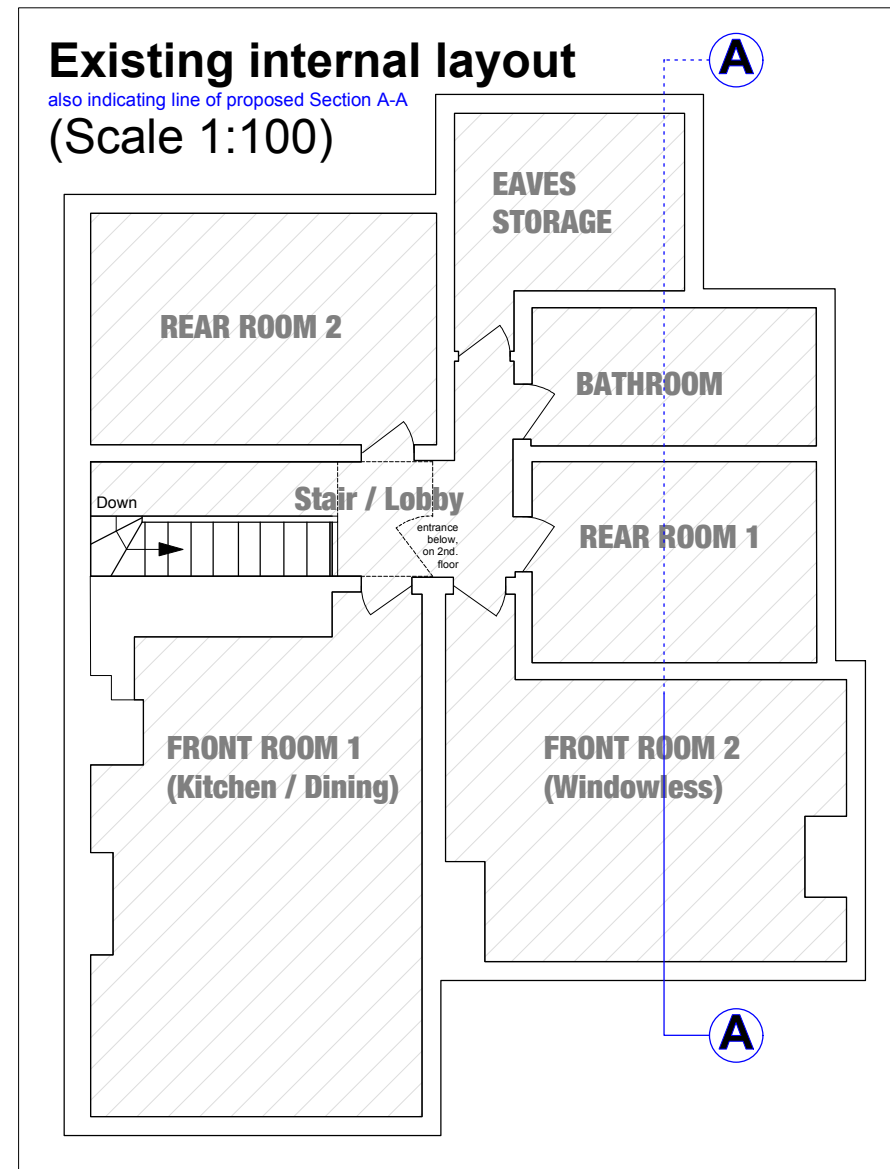

drawing n°:  
**NW36AJ-RW-002**  
last rev. date:  
no revisions