

1 - Elevation

W201, W202, W217 Unit 11
Fire Rating: NA
Total metal window number: 3

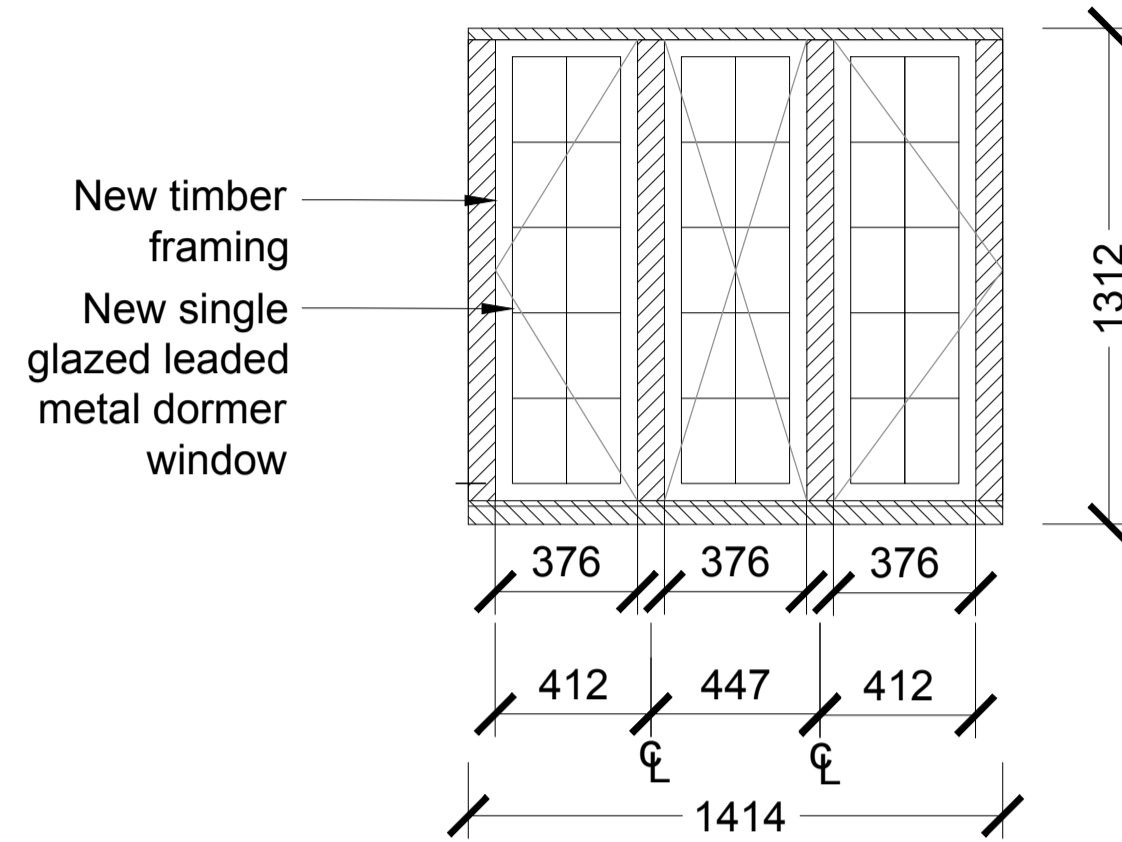

2 - Elevation

W203, W204, W205, W208 Unit 9
W212, W214, W215 Unit 10
Fire Rating: NA
Total metal window number: 21

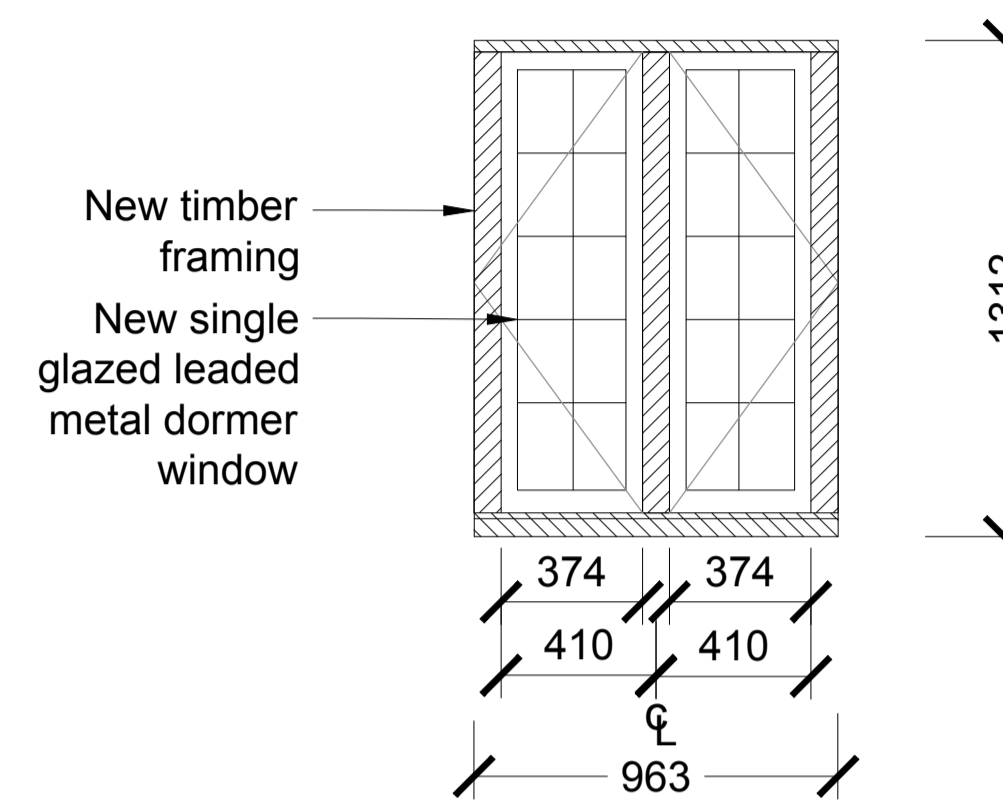

3 - Elevation

W209, W210 Unit 9, W211 Unit 10
Fire Rating: NA
Total metal window number: 6

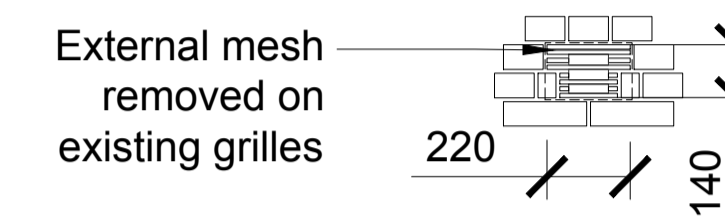

4 - Elevation (Grille)

Typical Grille Detail
Fire Rating: NA

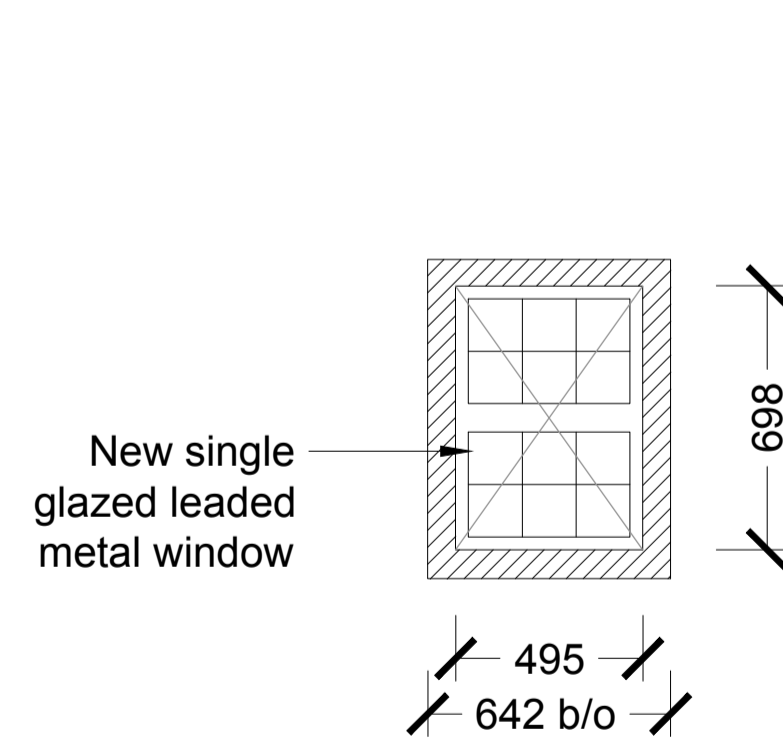

5 - Elevation

WB01 Unit 4 (Existing window replaced for a 30 min fire rating alternative)
Fire Rating: 30 mins
Total metal window number: 1

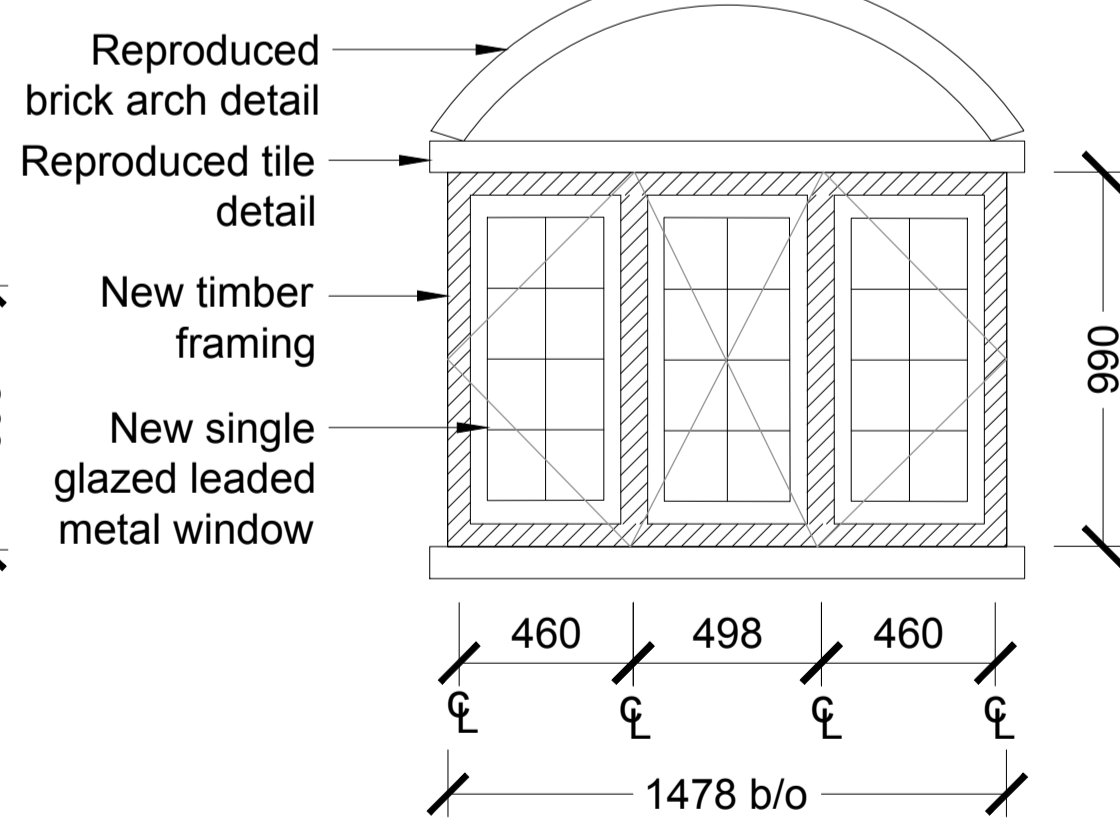

6 - Elevation

WB05 Unit 2
Fire Rating: NA
Total metal window number: 3

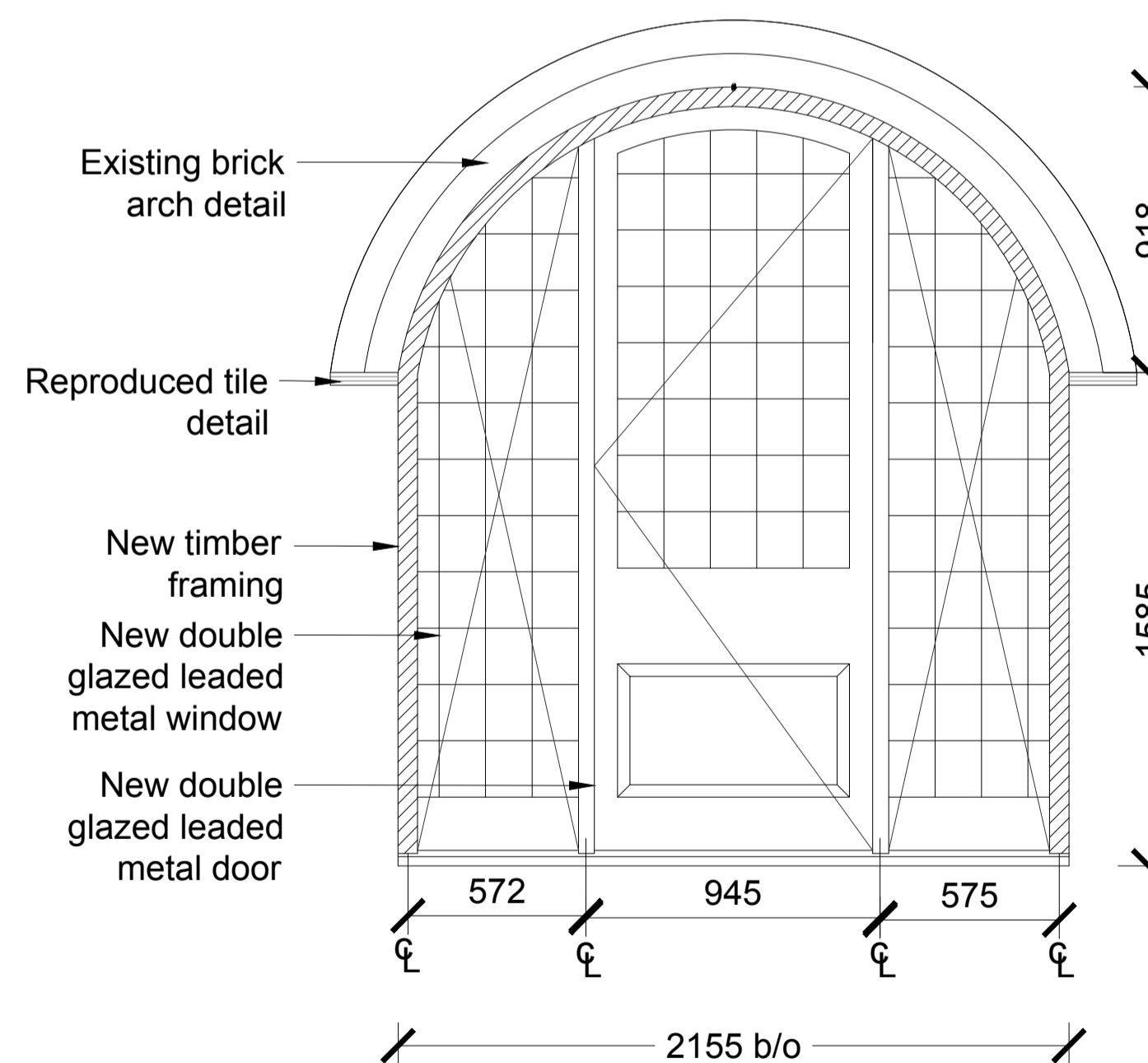

7 - Elevation

WB13 + WB12 + EXDB08 Unit 4
WB11 + WB10 + EXDB07 Unit 3
WB09 + WB08 + EXDB06 Unit 2
Fire Rating: NA
Total metal window number: 6
Total metal door number: 3

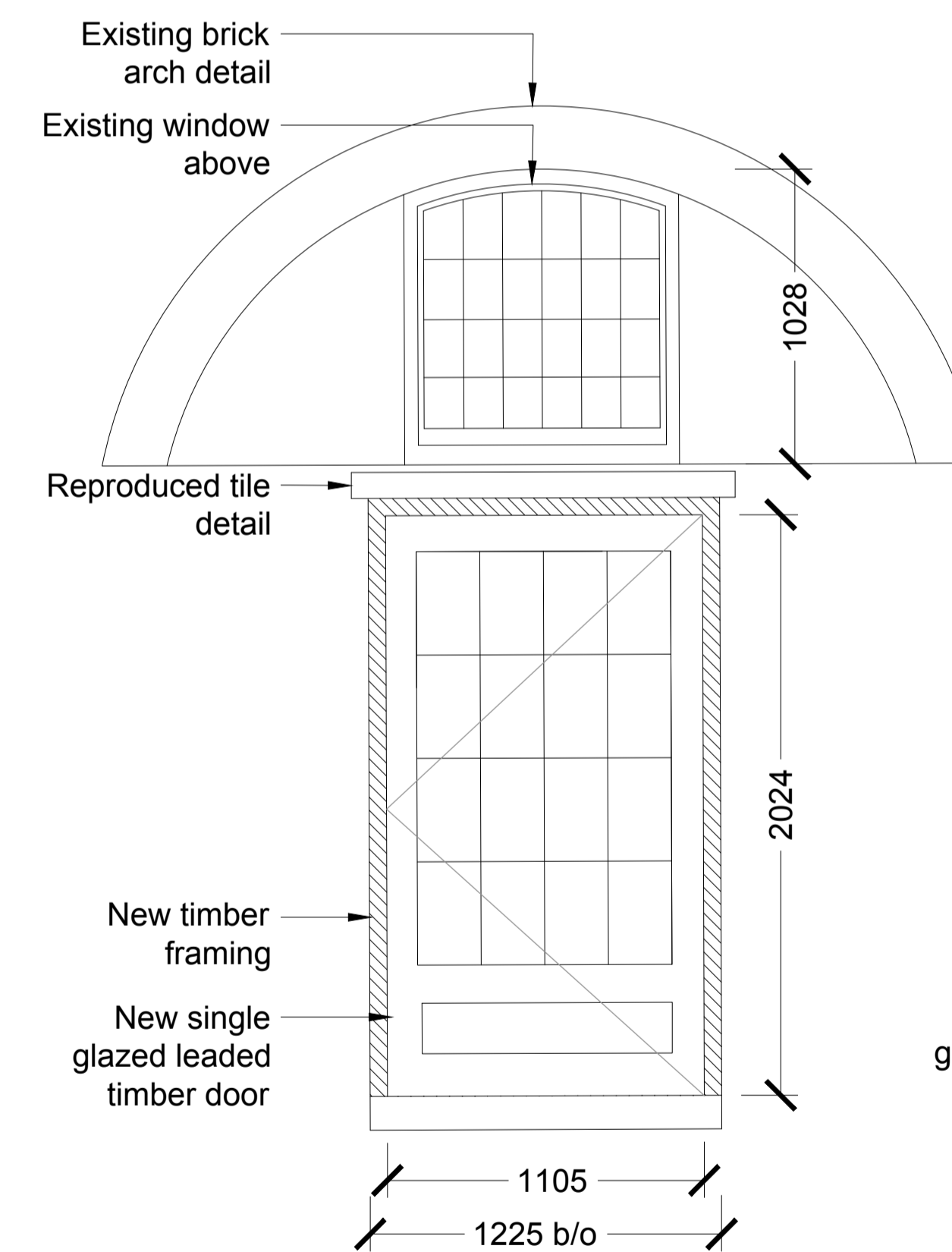

8 - Elevation

EXDG11 + WG32 Unit 6
Fire Rating: NA
Total timber door number: 1

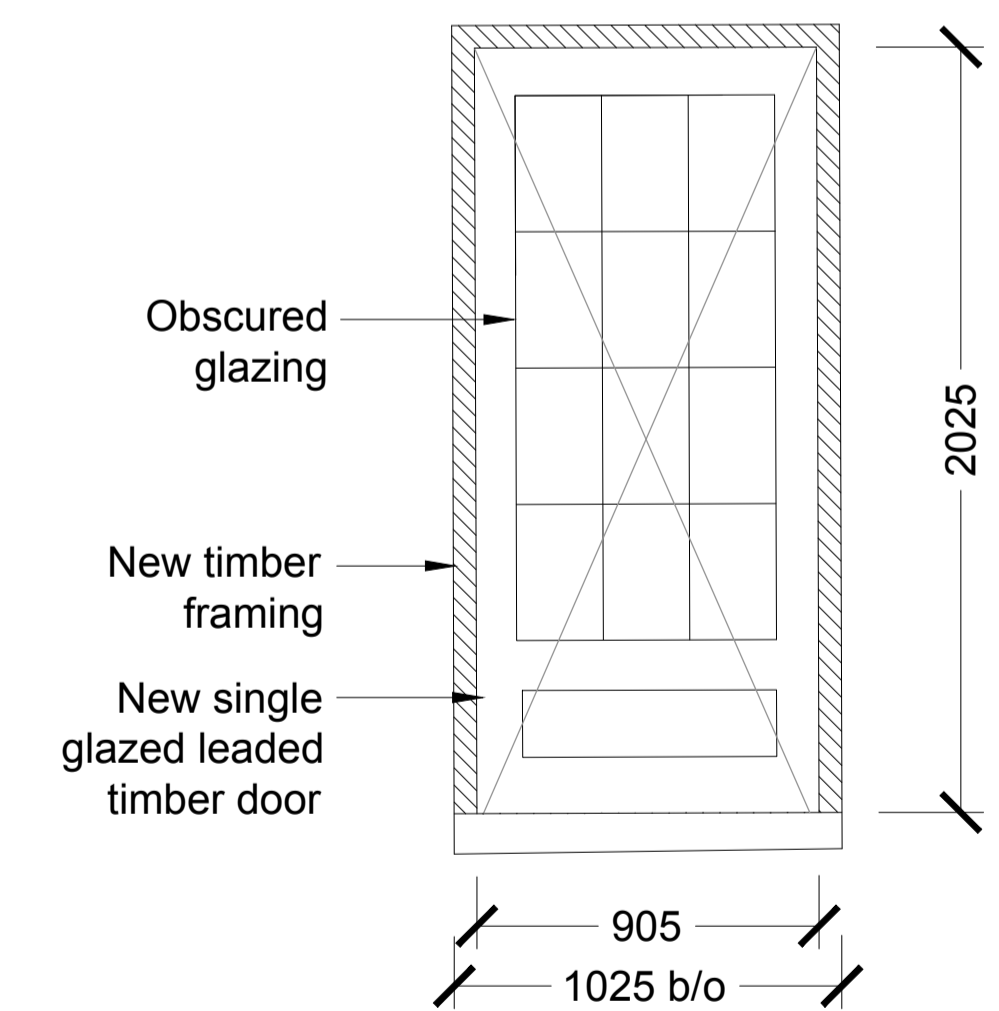

9 - Elevation

EXDG10
Existing door replaced by fixed door
Fire Rating: NA
Total timber door number: 1

Revisions					Revisions						
Rev	Date	By	Description	Checked	Approved	Rev	Date	By	Description	Checked	Approved
P1	21.12.18	TJS	For NMA Issue	JM	RH						

Window leading thickness - 12mm

b/o : Brick opening

Timber frame surround

Window handles and restrictions to match existing originals on all openable panels

A1
A3

Architect/Originator: Tate Planners	Unit G182, Stamford Works, 3, Gilt Street, London N16 6JH Tel: +44 (0)207 241 7481 Email: studio@tateplanners.com	Do not scale. All dimensions to be checked on site. This drawing is copyright.
Client: Platinum Land	8 Querpel House, 1 Duke of York Square, Kings Road, London, SW3 4LY	Date of Origin: 28.11.17
Project: Belisize Park Firestation		Drawn By: ASB
Drawing Title: Window, door and grille types to existing building		Scale: 1:20 (BA)
Client Sign Off	Drawing Number: BFS THA PR PA 520 P1	Drawing Status: Planning