

* 1-LG-D16 FD30

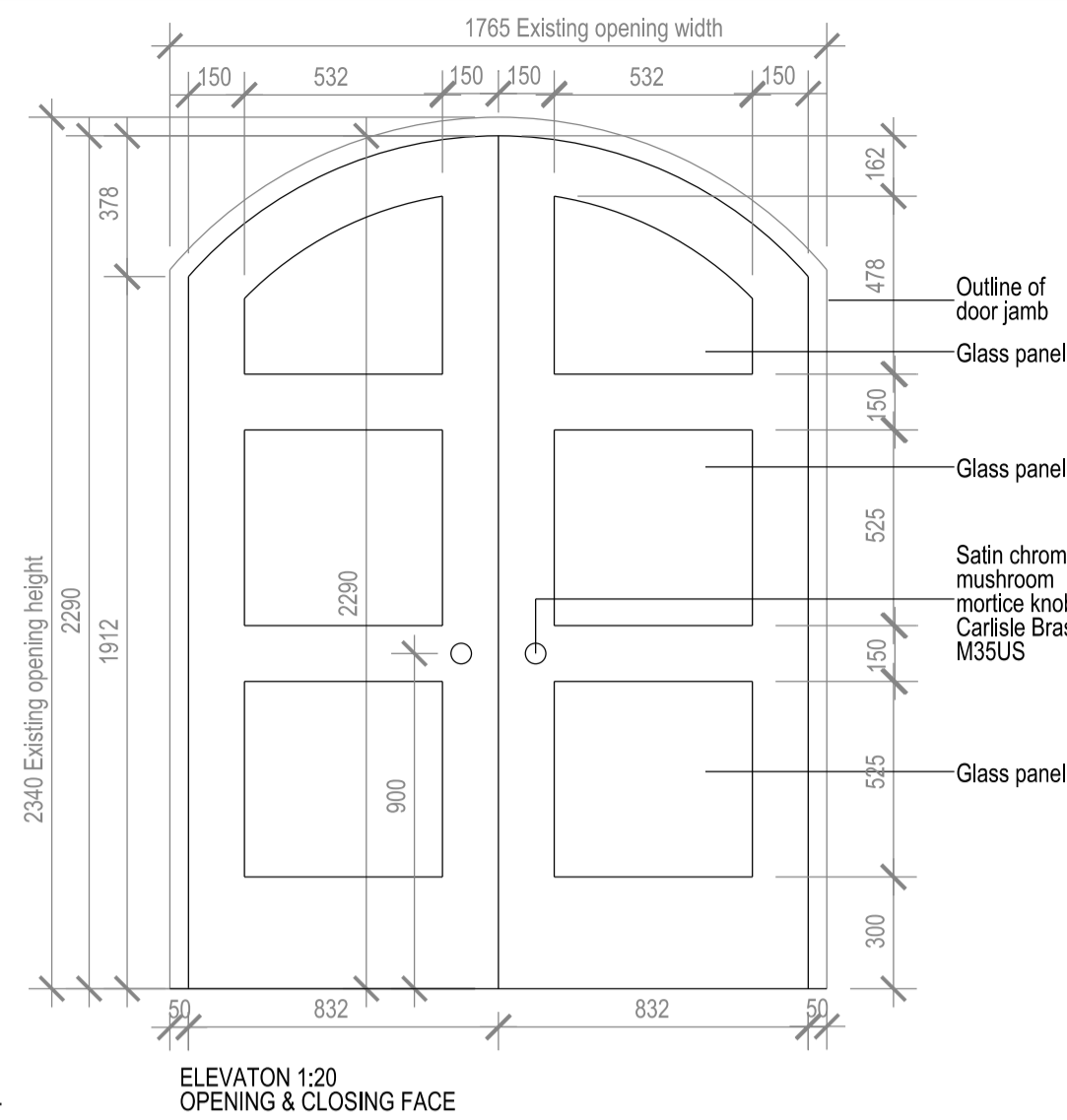

EXISTING CONDITION
Structural opening

NEW 3 X GLASS PANEL HARDWOOD TIMBER DOUBLE DOOR & DOOR FRAME TO MATCH DESIGN OF EXISTING ADJACENT DOOR 1-LG-D05.
TO ACHIEVE 30 MINUTE FIRE PROTECTION.
TO BE DECORATED IN EGGSHELL PAINT FINISH



* 1A-G-D05 FD30

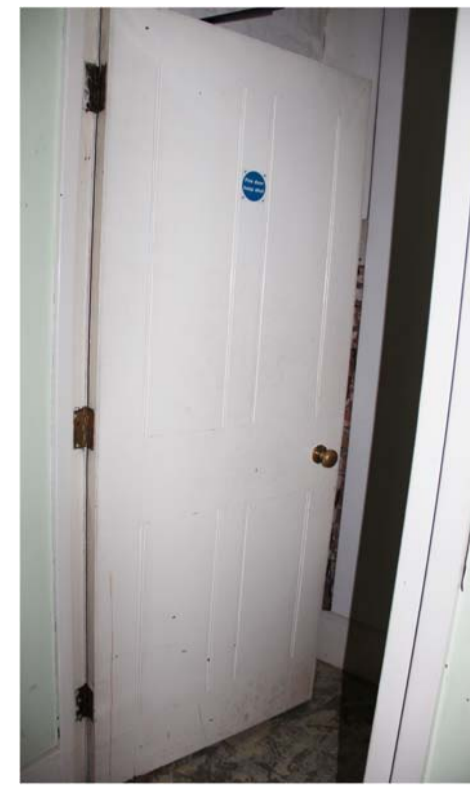

EXISTING CONDITION

NEW HARDWOOD TIMBER DOOR TO ACHIEVE 30 MINUTE FIRE PROTECTION.
TO BE DECORATED IN EGGSHELL PAINT FINISH.
EXISTING DOOR FRAME AND ARCHITRAVE TO BE RETAINED AND REDECORATED

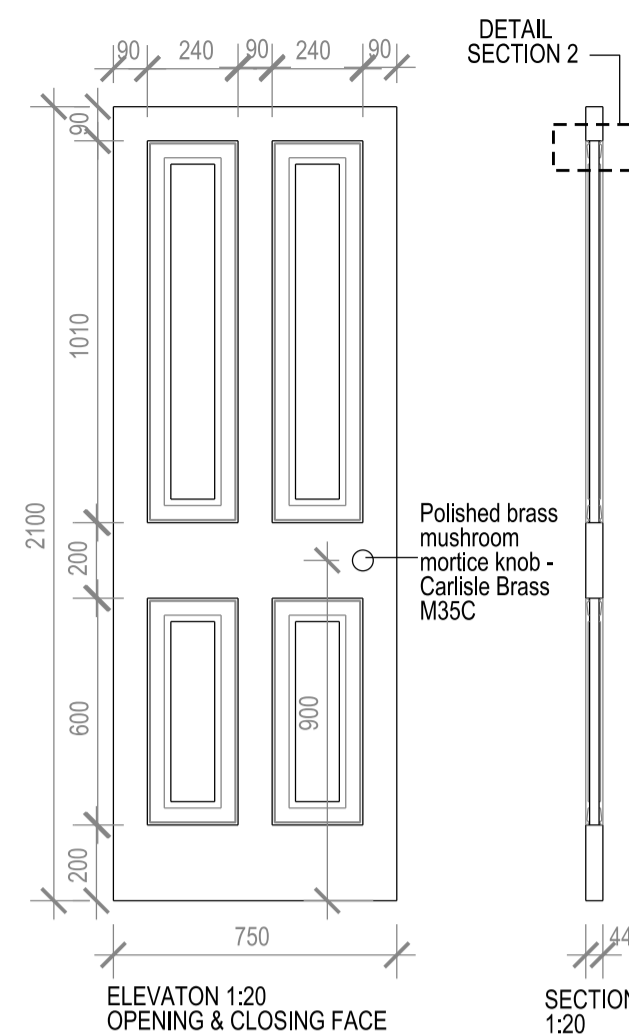

* 1A-G-D07 FD30



EXISTING CONDITION

NEW HARDWOOD TIMBER DOUBLE DOOR & FRAME.
TO BE DECORATED IN EGGSHELL PAINT FINISH.
ARCHITRAVE TO MATCH ADJACENT EXISTING IN ROOM 1AMS/2013

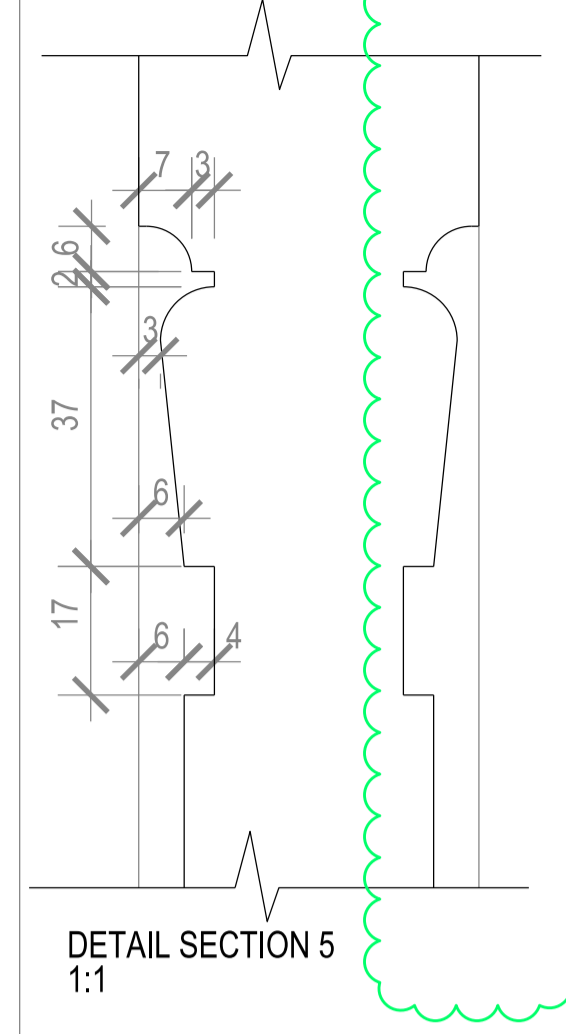
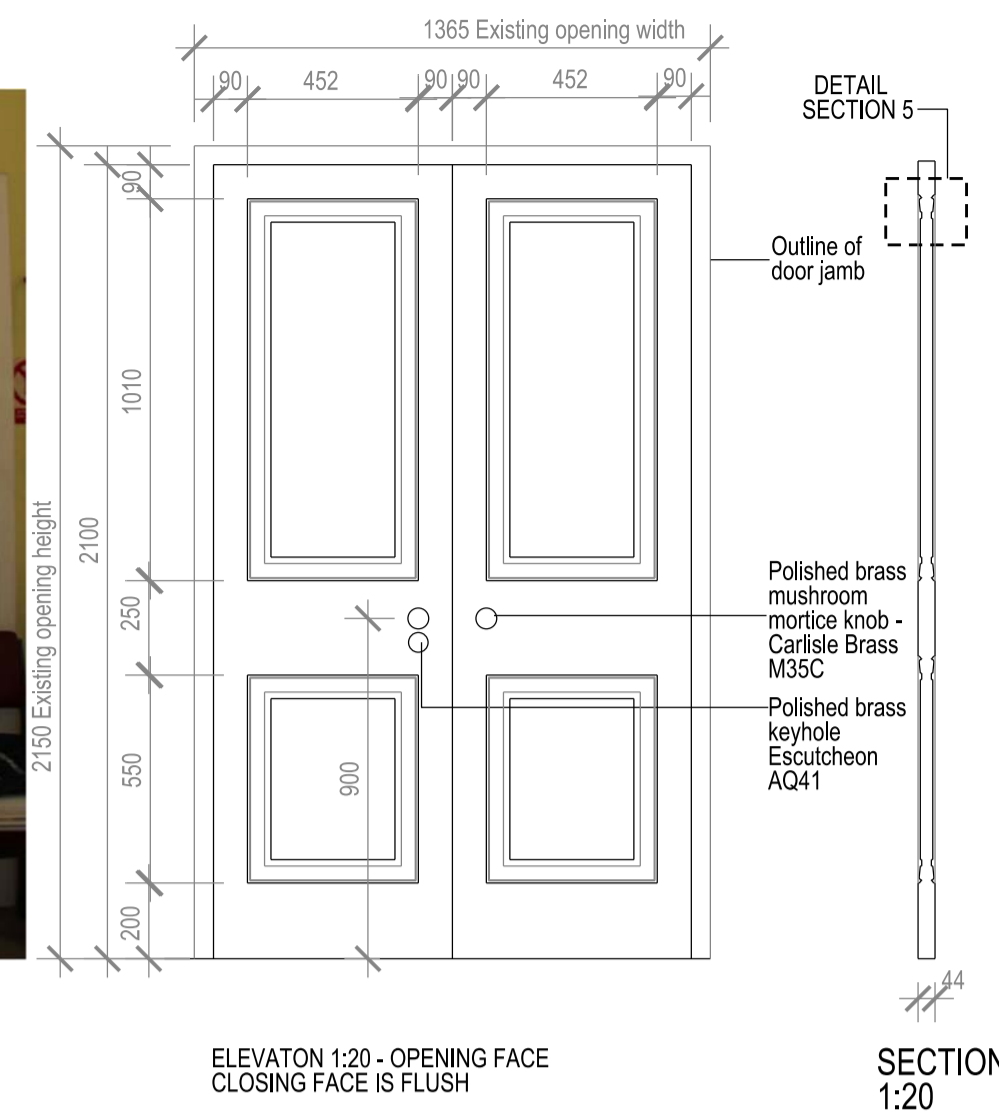

BUILDING DESIGN PARTNERSHIP LTD SHALL HAVE NO RESPONSIBILITY FOR ANY USE MADE OF THIS DOCUMENT OTHER THAN FOR THAT WHICH IT WAS PREPARED AND ISSUED.

ALL DIMENSIONS SHOULD BE CHECKED ON SITE.

DO NOT SCALE FROM THIS DRAWING.
ANY DRAWING ERRORS OR DIVERGENCES SHOULD BE BROUGHT TO THE ATTENTION OF BUILDING DESIGN PARTNERSHIP LTD AT THE ADDRESS SHOWN BELOW.

NOTES

* 1-G-D13 FD60



EXISTING CONDITION

NEW HARDWOOD TIMBER DOOR TO ACHIEVE 60 MINUTE FIRE PROTECTION
TO BE DECORATED IN EGGSHELL PAINT FINISH
EXISTING DOOR FRAME AND ARCHITRAVE TO BE REUSED

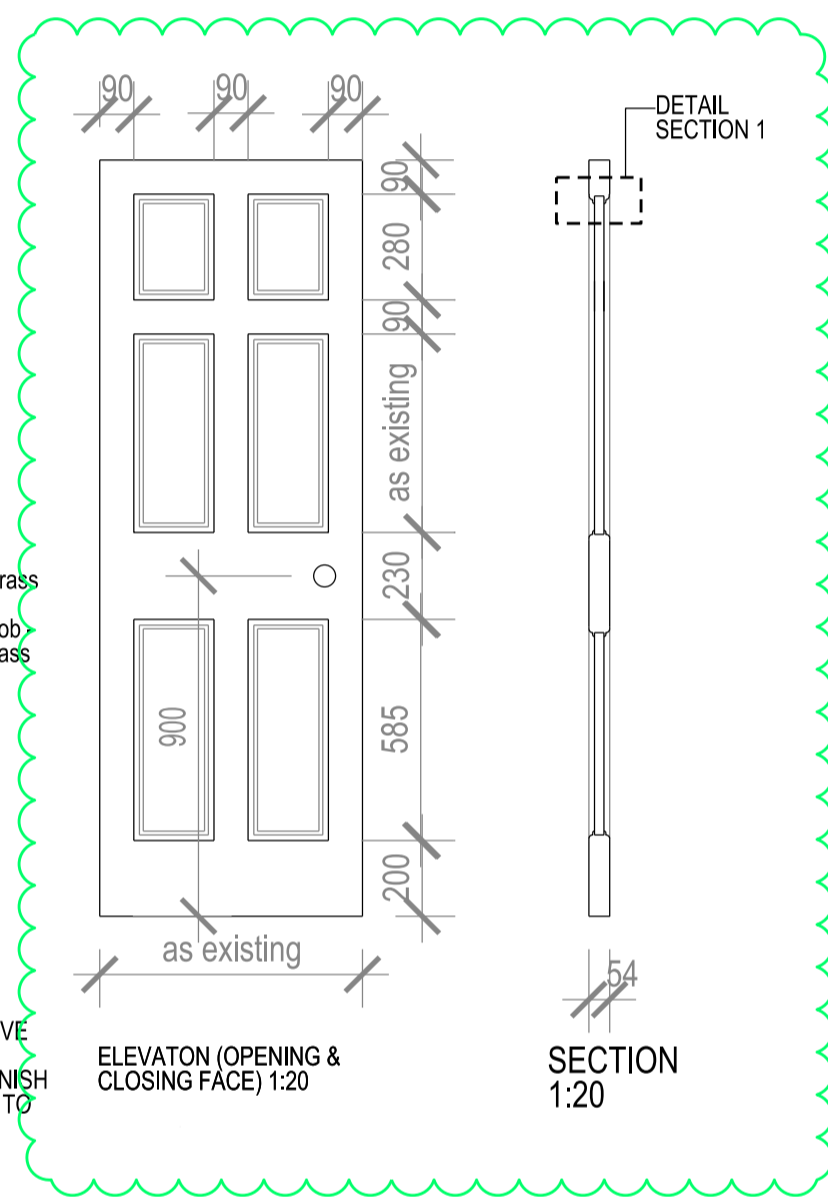

* 1A-1-D03 FD30



EXISTING CONDITION

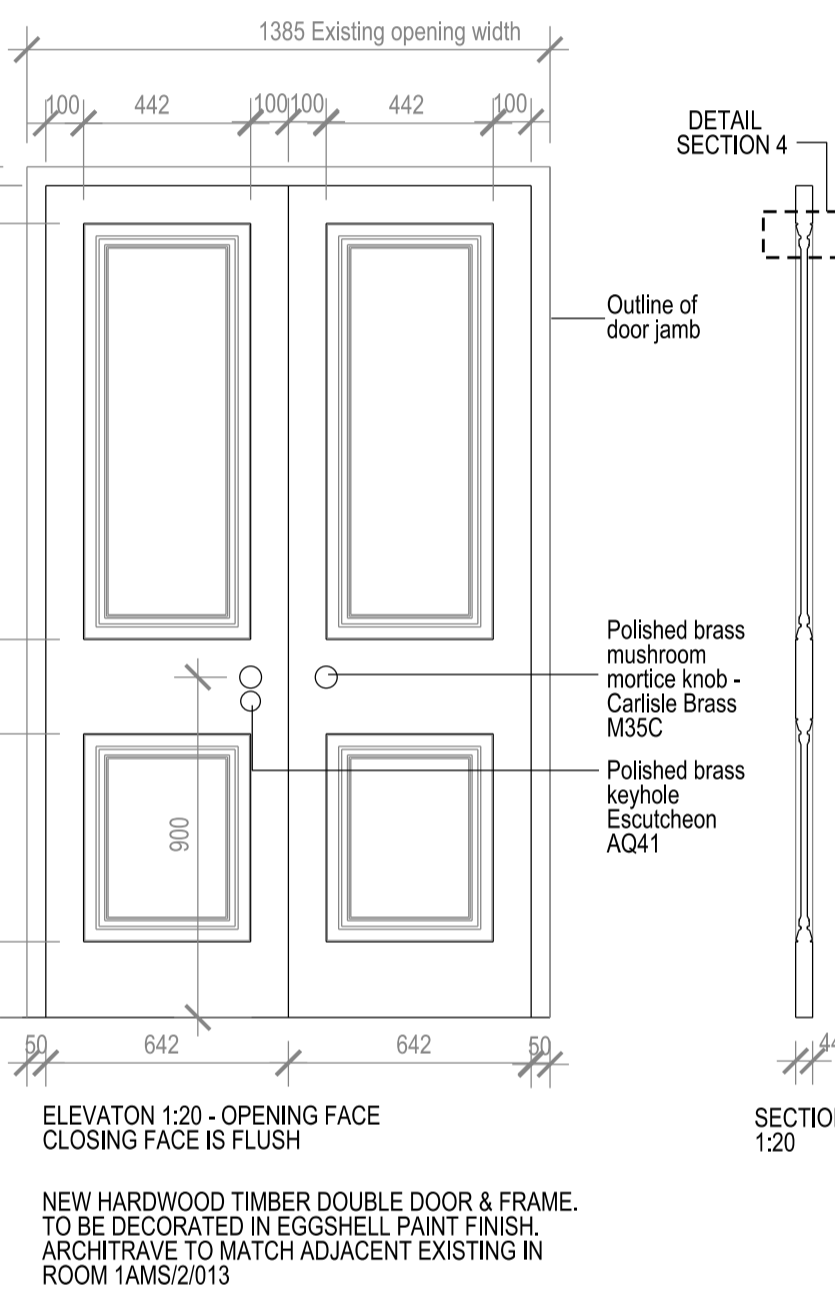

NEW HARDWOOD TIMBER DOUBLE DOOR & FRAME.
TO BE DECORATED IN EGGSHELL PAINT FINISH.
ARCHITRAVE TO MATCH ADJACENT EXISTING IN ROOM 1AMS/2013

* 1-2-D04 FD30

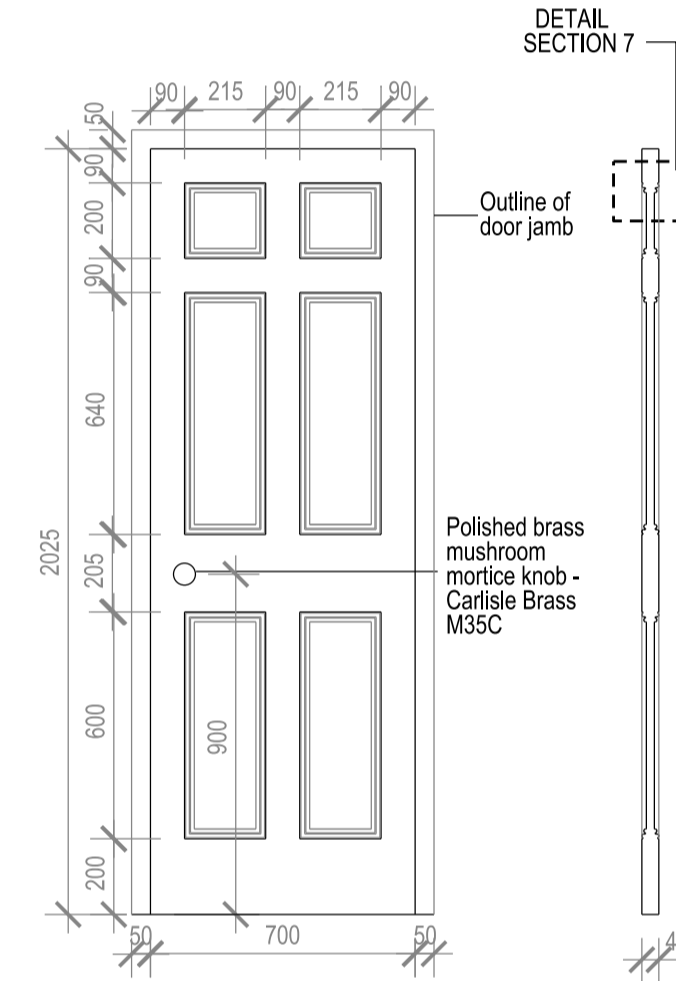

NEW HARDWOOD TIMBER DOOR & FRAME
TO ACHIEVE 30 MIN FIRE PROTECTION.
TO BE DECORATED IN EGGSHELL PAINT FINISH.
ARCHITRAVE TO MATCH ADJACENT EXISTING IN ROOM 1AMS/4/009

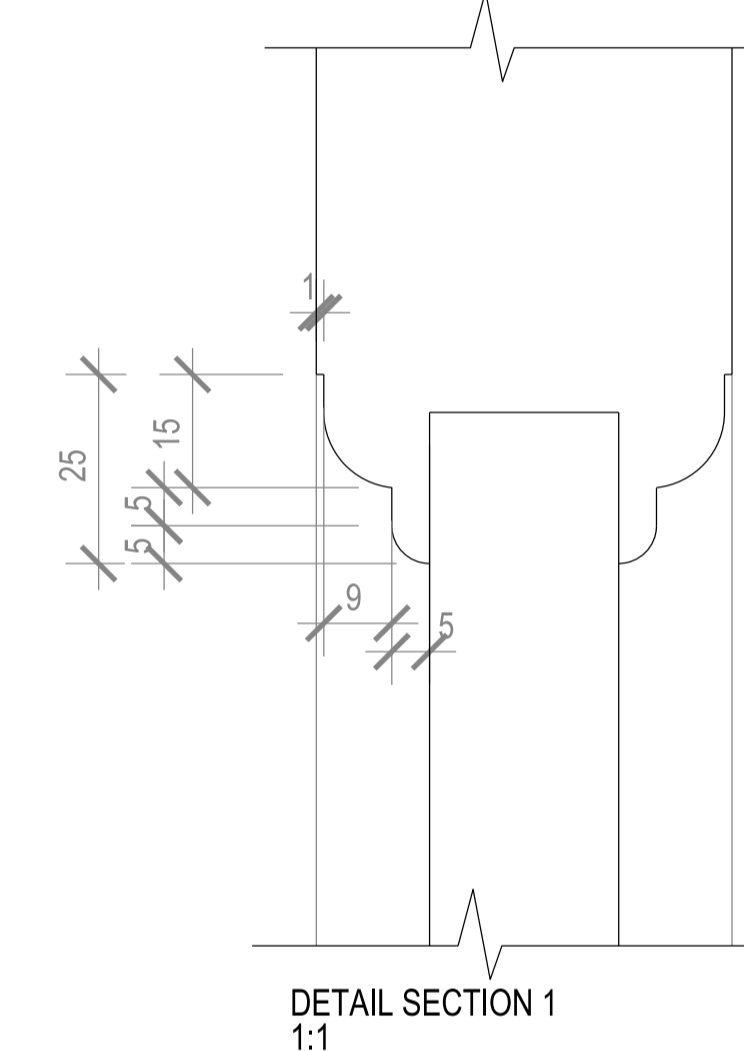

* 1-2-D06 * 1-2-D05 FD30

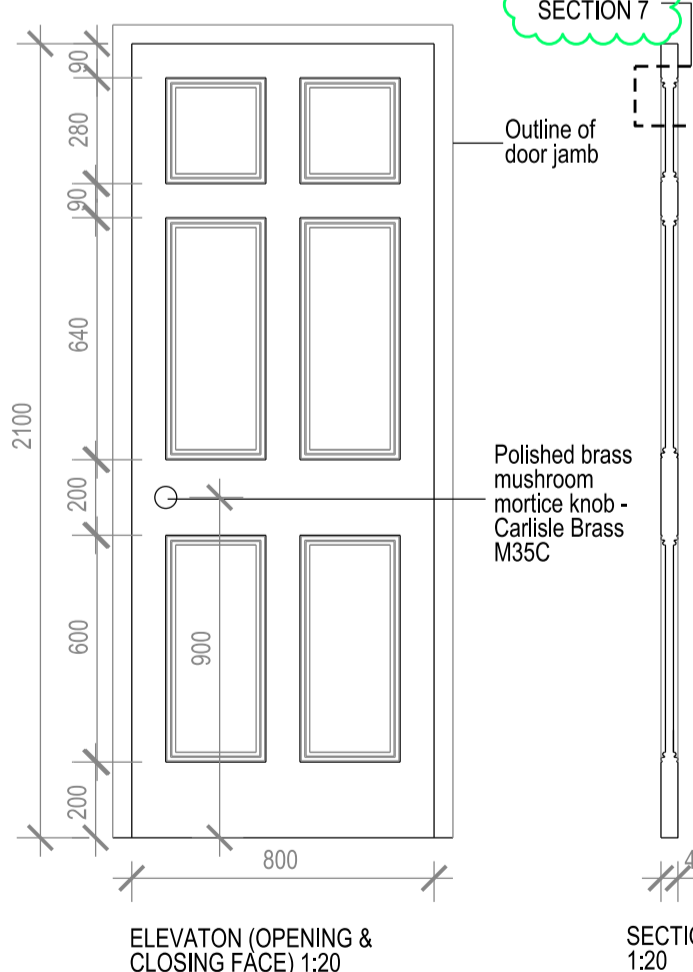

NEW HARDWOOD TIMBER DOOR & FRAME
TO ACHIEVE 30 MIN FIRE PROTECTION.
TO BE DECORATED IN EGGSHELL PAINT FINISH.

* 1-2-D11 FD60

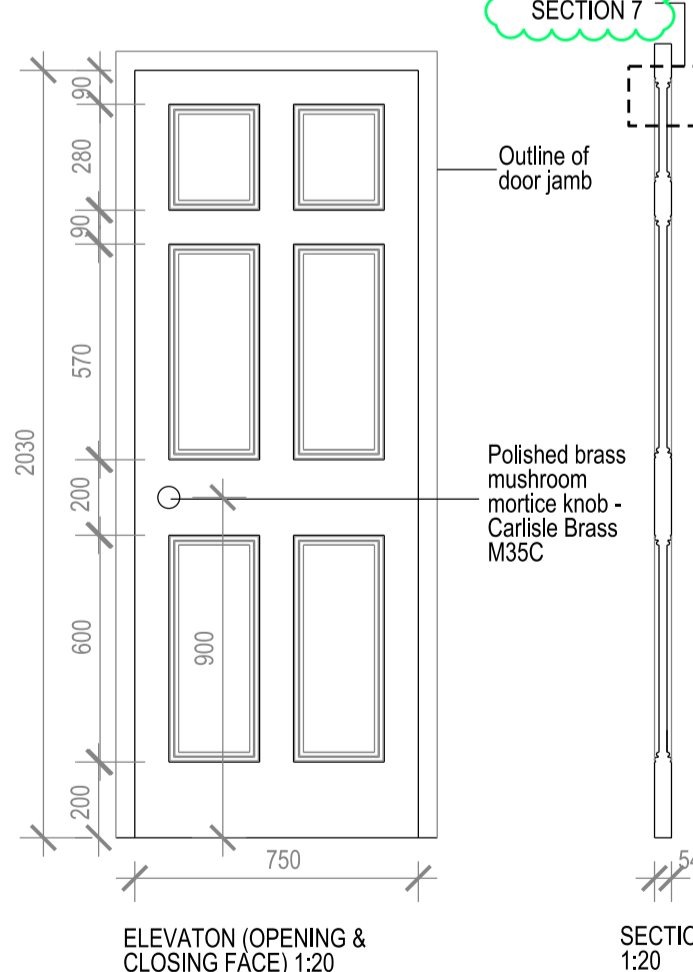

NEW HARDWOOD TIMBER DOOR & FRAME
TO ACHIEVE 30 MIN FIRE PROTECTION.
TO BE DECORATED IN EGGSHELL PAINT FINISH.

* 1A-2-D02 FD30



EXISTING CONDITION

NEW HARDWOOD TIMBER DOUBLE DOOR & FRAME.
TO BE DECORATED IN EGGSHELL PAINT FINISH.
ARCHITRAVE TO MATCH ADJACENT EXISTING IN ROOM 1AMS/4/011

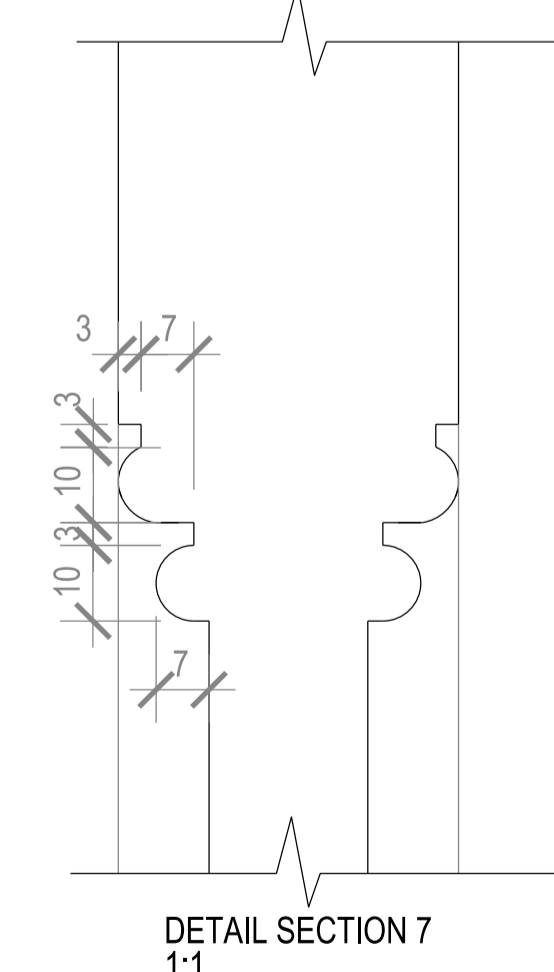
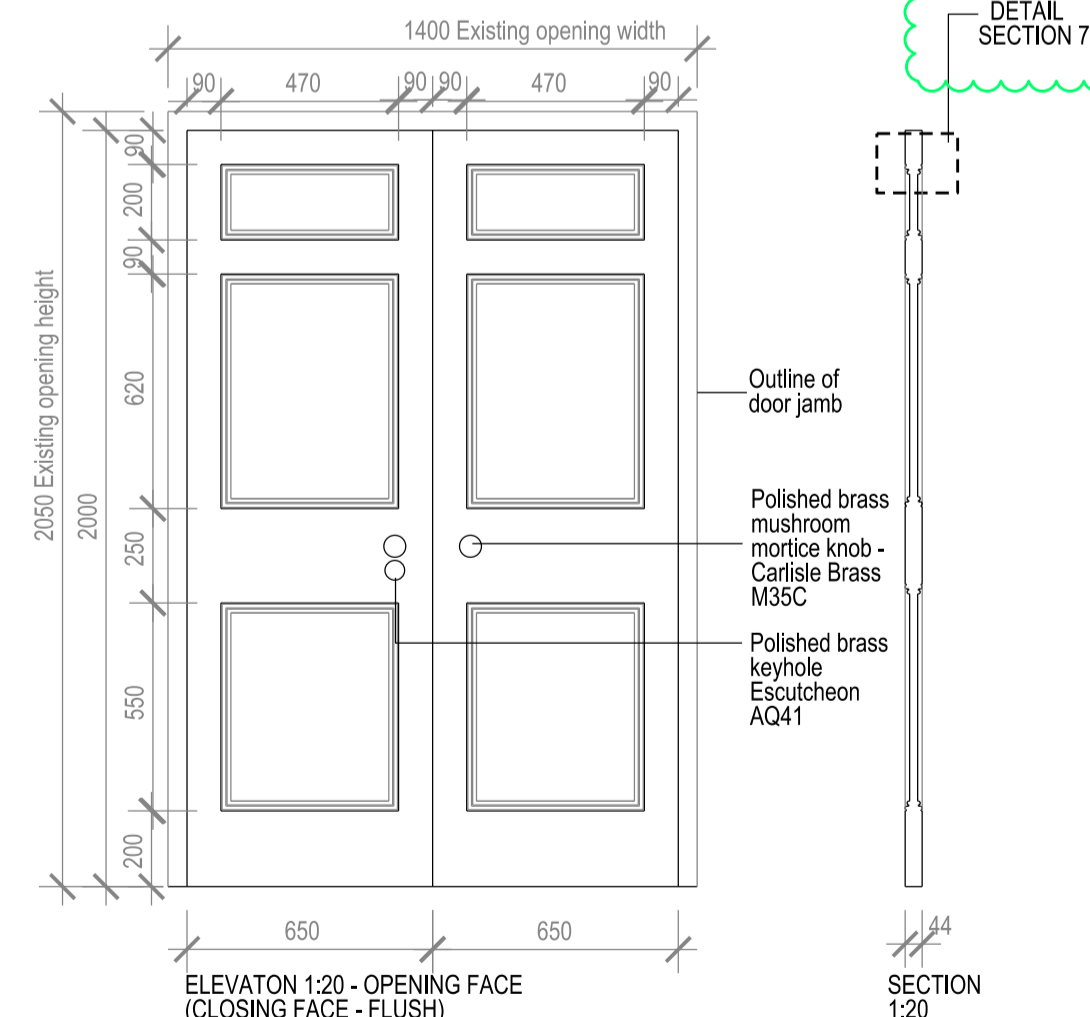

REVISION / DESCRIPTION	DRAWN	CHECKED	DATE
E - For Planning and Listed Building Consent Application	MF	AC	17/12/18
D - For Planning and Listed Building Consent Application	MF	AC	05/11/18
C - For Planning and Listed Building Consent Application	MF	AC	27/04/18
B - For Planning and Listed Building Consent	LBE	MB	23/06/17
A - For Planning and Listed Building Consent	RC	MB	01/06/17
FIRST ISSUE	RC		28/04/17

THE BRITISH MUSEUM

BDP.

18 Brewhouse Yard
Clerkenwell
London, EC1V 4LJ
United Kingdom

T +44 (0)20 7812 8000
F +44 (0)20 7812 8399
www.bdp.com

British Museum
Perimeter Properties Refurbishment

P2007246

ISSUED TITLE	SCALE
1 & 1A Montague Street Proposed doors Planning and LBC Application	1:20@A1
	DATE
	April '17
	REVISION
(32)AD002	E