

Existing Front Elevation

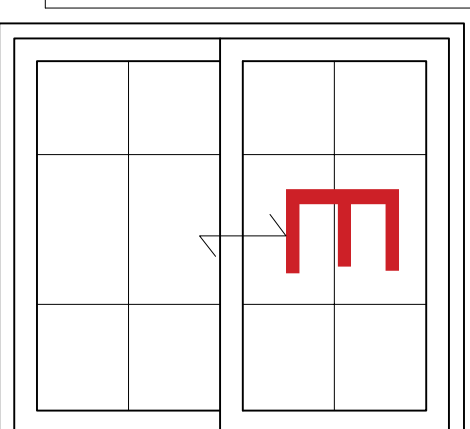
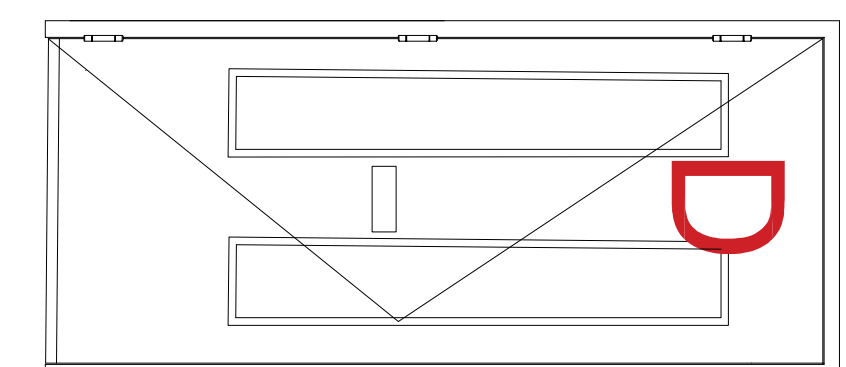
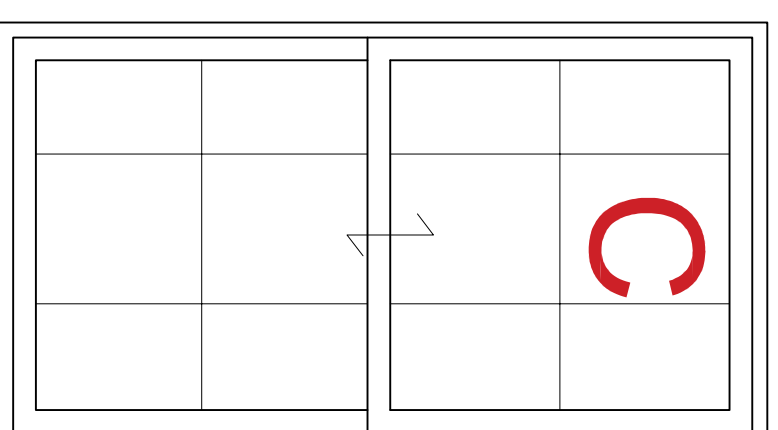
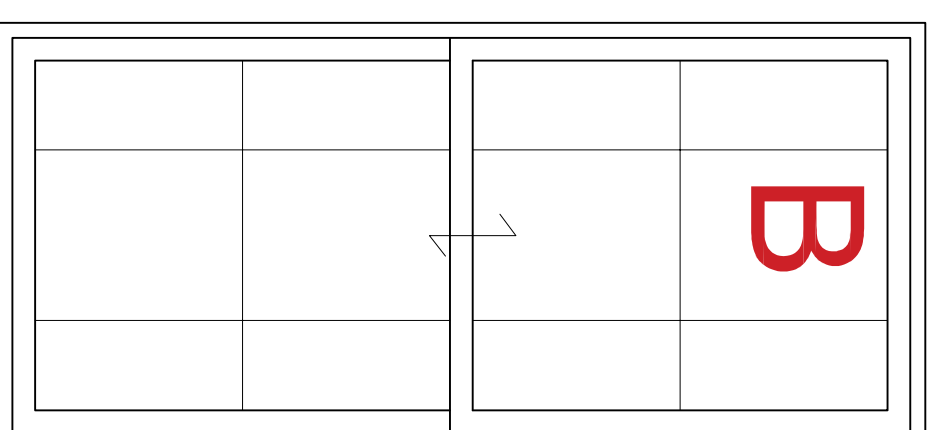
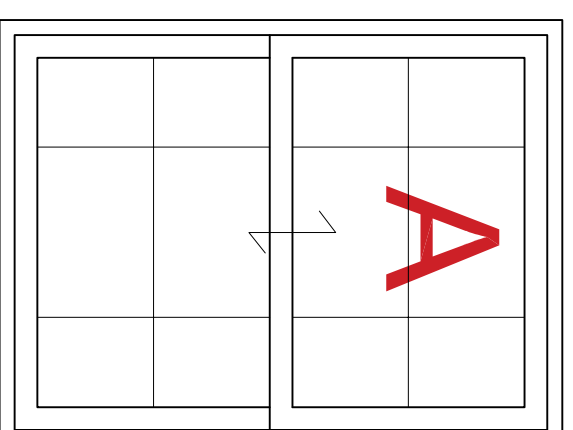
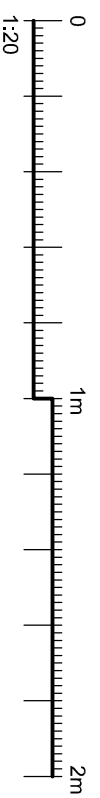

Proposed Windows

The contractor is responsible to ensure that no products are to be utilised that do not comply with relevant British and/or European Standards and/or Codes of Practice, Coshell Regulation, Construction regulations, or which are known or suspected at the time of product selection to be in breach of any applicable regulations, or which are known or suspected to be in breach of any applicable regulations. In accordance with good building practice.

The contractor is responsible for checking dimensions, tolerances, levels and references. The contractor is responsible for ensuring that the proposed windows and doors are installed in accordance with the drawings and specifications. Any discrepancy to be notified to Baily Garner LLP and rectified before proceeding with the works on site or shop drawings.

Where an item is covered by drawings to different scales, the larger scale drawing is to be worked to.

Do not scale drawings. Figured dimensions to be worked to in all cases.

This drawing and the copyrights and patents therein are the property of Baily Garner LLP and may not be used or reproduced without consent or attribution.

A3

CLIENT:	Clarton Housing Group	PROJECT:	Window & Door Replacement Works
ADDRESS:	26 Acton Street Camden London, WC1X 9LX	TITLE:	Existing Front Photos & Proposed Window, Door Schedules
SCALE:	1:20 @ A3	PURPOSE OF ISSUE:	Planning
DRAWING NO:	30668	DATE:	07/11/18
REVISION:		REVISION:	



REVISION

D C

DATE