

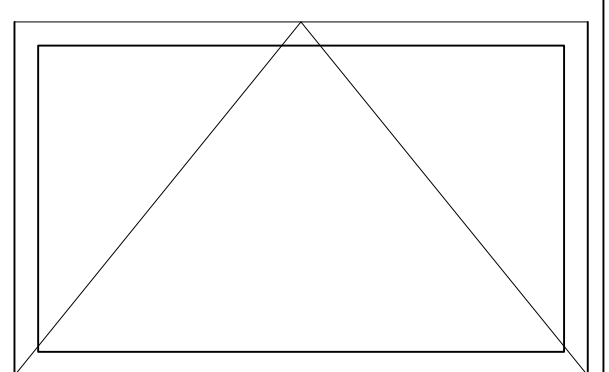

## Existing Rear Elevation

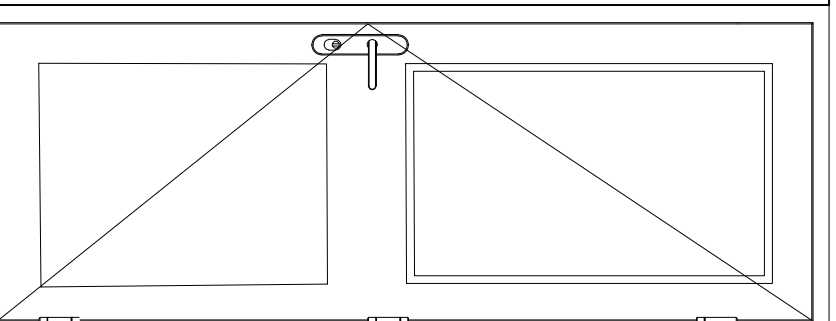
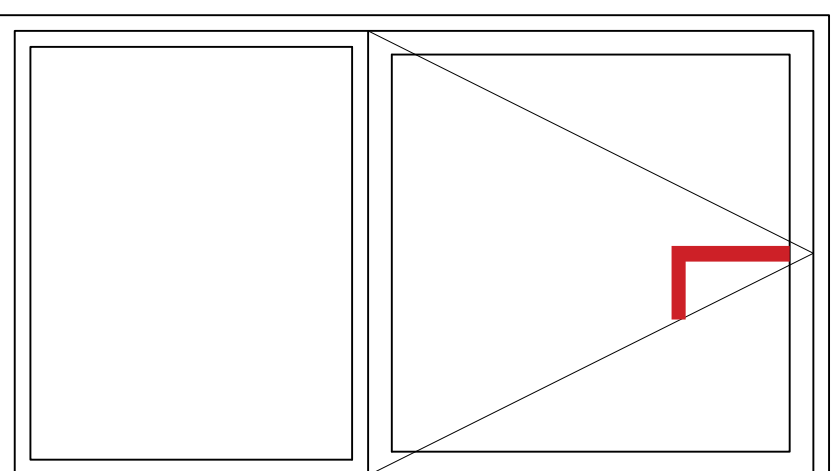
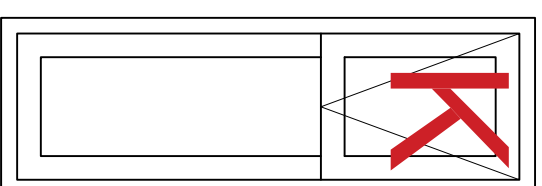
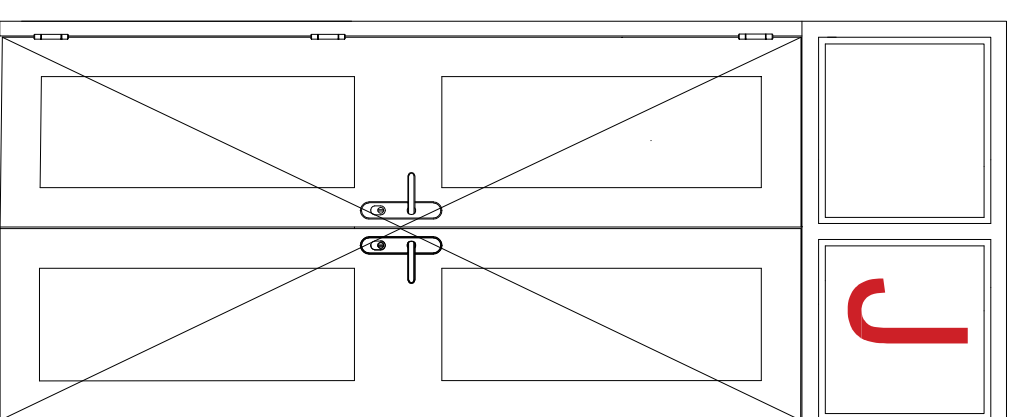
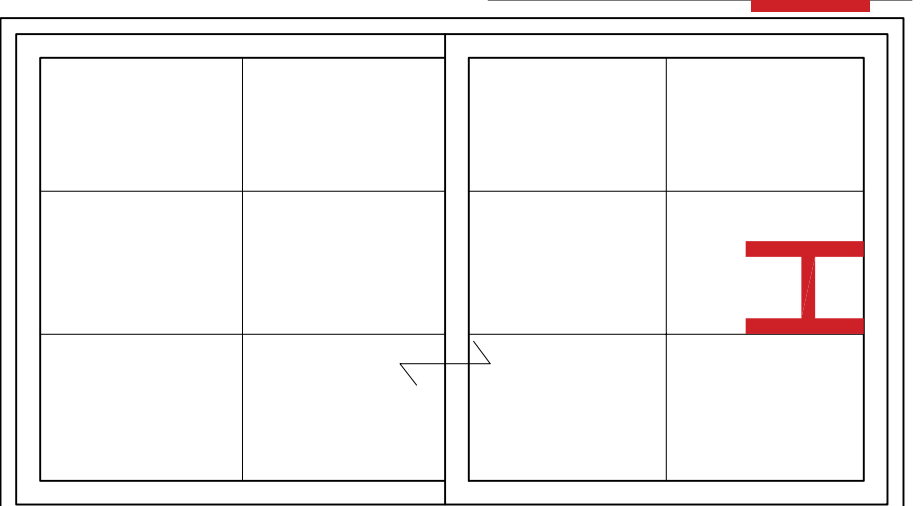
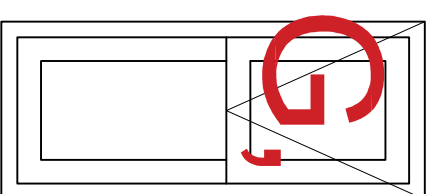
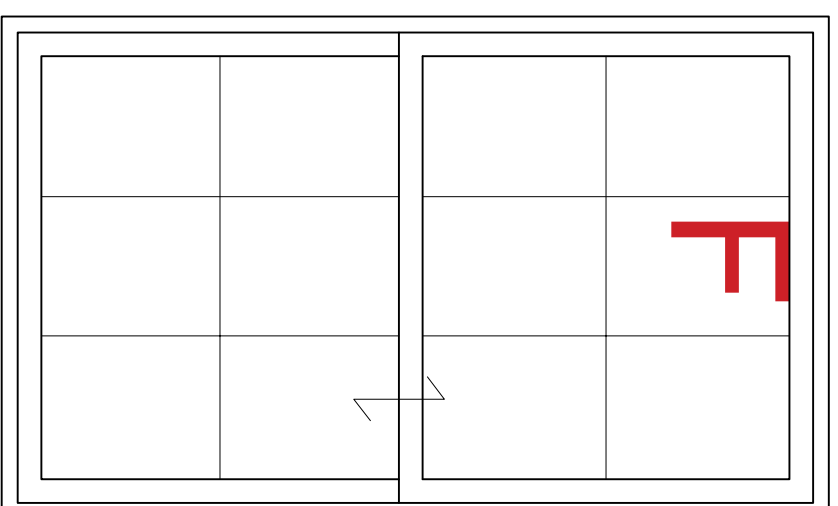
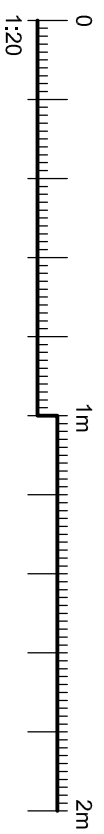

## Proposed Windows

The contractor is responsible to ensure that no products are to be utilised that do not comply with relevant British and/or European Standards and/or Codes of Practice, CEHR Regulations, Construction regulations, or which are shown or suspected at the time of product selection and/or construction to be deleterious to health and safety or to the durability of the work or not in accordance with good building practices.

The contractor is responsible for checking dimensions, tolerances, levels and references. This drawing is to be read in conjunction with all relevant consultants or specialists drawings. Any discrepancy to be notified to Baily Garner LLP and rectified before proceeding with the works on site or being drawn up.

Where an item is covered by drawings to different scales, the larger scale drawing is to be worked to.

Do not scale drawings. Figured dimensions to be worked to in all cases. This drawing and the copyrights and patents therein are the property of Baily Garner LLP and may not be used or reproduced without consent or attribution.

CLIENT:  
Clairon Housing Group

ADDRESS:  
45 Action Street  
London,  
WC1X 9LZ

PROJECT:  
Window & Door Replacement Works

TITLE:  
Existing Rear Photos & Proposed  
Windows Schedule  
PURPOSE OF ISSUE:  
Planning

SCALE:  
1:20 @A3  
JOB NO.  
30668

DATE:  
07/11/18  
DRAWING NO.  
P02  
REVISION:



146-148 ELTHAM HILL  
LONDON SE9 5DY  
1 (020) 8294 1000  
1 (020) 8294 1320  
e. general@bailygarner.co.uk

REVISION

D C

DATE